

HP StorageWorks 60 Modular Smart Array Enclosure User Guide



November 2006 (Second Edition)
Part Number 405868-002



© Copyright 2006 Hewlett-Packard Development Company, L.P.

The information contained herein is subject to change without notice. The only warranties for HP products and services are set forth in the express warranty statements accompanying such products and services. Nothing herein should be construed as constituting an additional warranty. HP shall not be liable for technical or editorial errors or omissions contained herein.

Microsoft and Windows are U.S. registered trademarks of Microsoft Corporation.

November 2006 (Second Edition)

Part Number 405868-002

Audience assumptions

This document is for the person who installs, administers, and troubleshoots servers and storage systems. HP assumes you are qualified in the servicing of computer equipment and trained in recognizing hazards in products with hazardous energy levels.

Contents

Component identification	6
Front panel LEDs and buttons	6
Rear panel components	7
Dual 7-segment display board	7
Rear panel LEDs and buttons	8
SAS and SATA device numbers	9
SAS and SATA hard drive LEDs	9
SAS and SATA hard drive LED combinations	9
Operations	11
Power up	11
Power down the server	11
Setup	13
Rack planning resources	13
Optimum environment	13
Space and airflow requirements	13
Temperature requirements	14
Power requirements	14
Electrical grounding requirements	15
Rack warnings	15
Shipping contents	15
Rack mounting hardware kit contents	16
Converting rails for round-hole racks	16
Installing a storage enclosure into the rack	17
Installing hardware options	19
Installing servers	19
Choosing a configuration	20
Single-enclosure configuration	20
Cascading (1+1) configuration	21
Cabling the storage enclosure	21
SAS cabling guidelines	21
Supported cables	21
Power cords	22
Updating firmware	22
Hardware options installation	23
Hard drive options	23
SAS and SATA hard drive guidelines	23
SAS or SATA hard drive	23
Configuration and utilities	25
Configuration tools	25
Array Configuration Utility	25
Option ROM Configuration for Arrays	25
Smart Components for ROM Flash	26
Management tools	26
HP Systems Insight Manager	26
Management Agents	26
Diagnostic tools	26
Integrated Management Log	26

Array Diagnostic Utility	27
Remote support and analysis tools	27
Open Services Event Manager	27
Keeping the system current	27
Change control and proactive notification	27
Care Pack	27
Troubleshooting	28
When the storage enclosure does not start.....	28
Diagnostic questions	29
Are the power supply/system fan LEDs green?	29
Is the system power LED green?	29
Recognizing hard drive failure	29
Effects of a hard drive failure	30
Compromised fault tolerance	30
Recovering from compromised fault tolerance.....	30
Factors to consider before replacing hard drives	30
Automatic data recovery (rebuild).....	31
Time required for a rebuild	31
Failure of another drive during rebuild	32
Drive failure in a NetWare environment.....	32
Failed drives or interim recovery mode.....	32
Handling disk drive failures	33
Regulatory compliance notices	34
Regulatory compliance identification numbers	34
Federal Communications Commission notice.....	34
FCC rating label.....	34
Class A equipment.....	35
Class B equipment	35
Declaration of conformity for products marked with the FCC logo, United States only.....	35
Modifications.....	36
Cables.....	36
Canadian notice (Avis Canadien).....	36
European Union regulatory notice	36
Disposal of waste equipment by users in private households in the European Union	37
Japanese notice	37
BSMI notice	37
Korean notice	38
Power cord statement for Japan.....	38
Electrostatic discharge	39
Preventing electrostatic discharge	39
Grounding methods to prevent electrostatic discharge.....	39
Specifications	40
Environmental specifications	40
Storage enclosure specifications	40
Technical support.....	41
Before you contact HP.....	41
HP contact information.....	41
Customer Self Repair	41
Acronyms and abbreviations.....	49

Index..... 51

Component identification

In this section

- Front panel LEDs and buttons 6
- Rear panel components..... 7
- Rear panel LEDs and buttons 8
- SAS and SATA device numbers 9
- SAS and SATA hard drive LEDs 9
- SAS and SATA hard drive LED combinations 9

Front panel LEDs and buttons

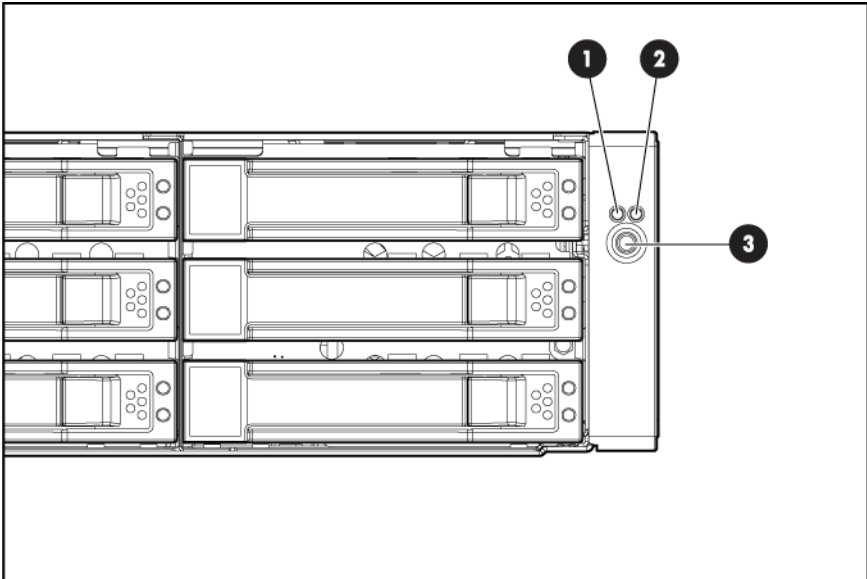

Item	Description	Status
1	Heartbeat LED	Green = System activity Off = No system activity
2	Fault LED	Amber = Fault condition Off = No fault condition
3	UID button/LED	Blue = Identified Blue flashing = Active remote management Off = No active remote management

Rear panel components

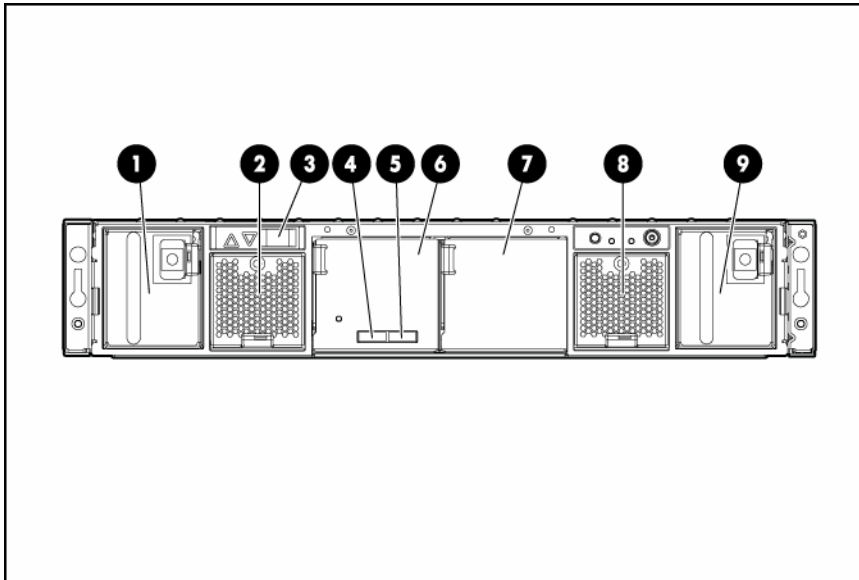

Item	Description
1	Power supply 1
2	Fan module 1
3	Dual 7-segment display board (for box ID numbering)
4	SAS in connector
5	SAS out connector
6	I/O module bay
7	For future use
8	Fan module 2
9	Power supply 2

Dual 7-segment display board

The dual 7-segment display board displays the host controller-assigned port and box ID number for the MSA60 to which it is connected.

The host controller has two external ports. Each port supports up to two MSA60 enclosures, for a total of up to four MSA60 enclosures per host controller. See "Choosing a configuration (on page 20)."

When connected to multiple MSA60 enclosures, the host controller assigns the box ID number according to connection order.

The following table shows MSA60 enclosures and their associated port and box ID assignments:

Storage enclosure	Port	Box ID
MSA60 1	P1	B1
MSA60 2	P1	B2
MSA60 3	P2	B3
MSA60 4	P2	B4

To view the port to which the MSA60 is connected, press the up arrow button on the 7-segment display board. To view the box ID number, press the down arrow button.

Rear panel LEDs and buttons

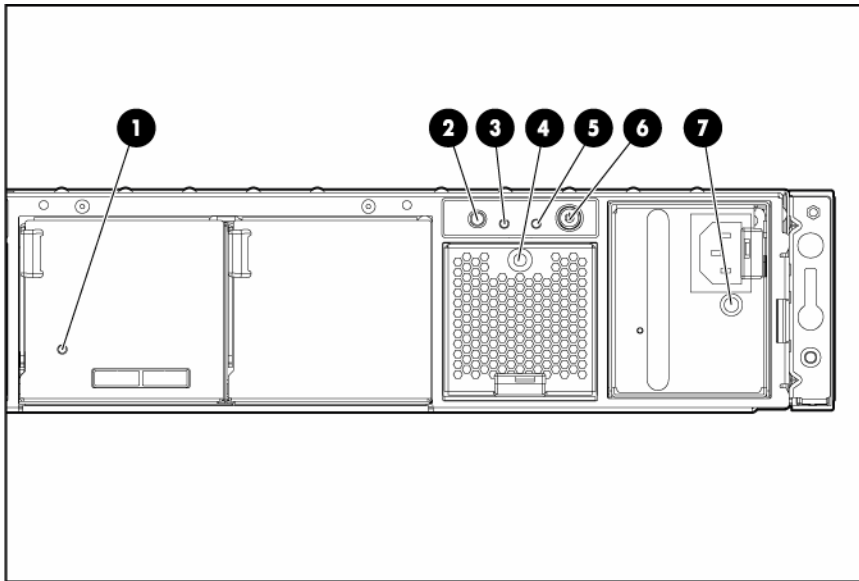

Item	Description	Status
1	I/O module LED	Green = System activity Amber flashing = Fault Off = No system activity
2	UID button/LED	Blue = Identified Blue flashing = Active remote management Off = No active remote management
3	Heartbeat LED	Green = System activity Off = No system activity
4	System fan LED	Green = Normal operation Amber flashing = Fault condition Off = Fan unseated from connector or failed
5	System fault LED	Amber = Fault condition Off = No fault condition
6	Power On/Standby button/system power LED	Green = On Amber = Standby (auxiliary power present) Off = Off
7	Power supply LED	Green = Power turned on and power supply functioning properly Amber flashing = Standby (auxiliary power present) Off = One or more of the following conditions exists: <ul style="list-style-type: none"> • AC power unavailable • Power supply failed • Power supply exceeded current limit

SAS and SATA device numbers

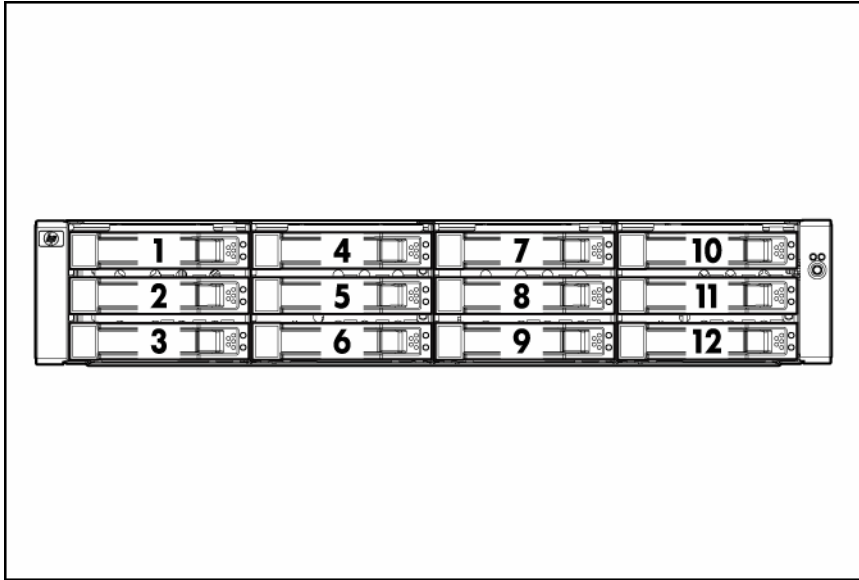

SAS and SATA hard drive LEDs

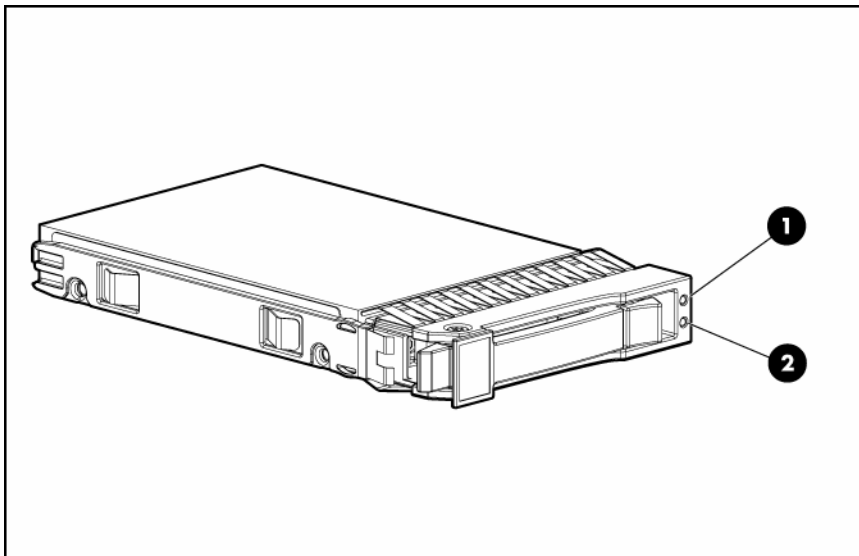

Item	Description
1	Fault/UID LED (amber/blue)
2	Online LED (green)

SAS and SATA hard drive LED combinations

 **NOTE:** Predictive failure alerts can occur only when the storage enclosure is connected to a Smart Array controller.

Online/activity LED (green)	Fault/UID LED (amber/blue)	Interpretation
On, off, or flashing	Alternating amber and blue	The drive has failed, or a predictive failure alert has been received for this drive; it also has been selected by a management application.
On, off, or flashing	Steadily blue	The drive is operating normally, and it has been selected by a management application.
On	Amber, flashing regularly (1 Hz)	A predictive failure alert has been received for this drive. Replace the drive as soon as possible.
On	Off	The drive is online, but it is not currently active.
Flashing regularly (1 Hz)	Amber, flashing regularly (1 Hz)	Do not remove the drive. Removing a drive may terminate the current operation and cause data loss. The drive is part of an array that is undergoing capacity expansion or a stripe size migration, but a predictive failure alert has been received for this drive. To minimize the risk of data loss, do not replace the drive until the expansion or migration is complete.
Flashing regularly (1 Hz)	Off	Do not remove the drive. Removing a drive may terminate the current operation and cause data loss. The drive is rebuilding, or it is part of an array that is undergoing capacity expansion or a stripe size migration.
Flashing irregularly	Amber, flashing regularly (1 Hz)	The drive is active, but a predictive failure alert has been received for this drive. Replace the drive as soon as possible.
Flashing irregularly	Off	The drive is active and it is operating normally.
Off	Steadily amber	A critical fault condition has been identified for this drive and the controller has placed it offline. Replace the drive as soon as possible.
Off	Amber, flashing regularly (1 Hz)	A predictive failure alert has been received for this drive. Replace the drive as soon as possible.
Off	Off	The drive is offline, a spare, or not configured as part of an array.

Operations

In this section

Power up.....	11
Power down the server.....	11



Important Safety Information

Before installing this product, read the *Important Safety Information* document provided.

Power up

Observe the following guidelines before powering up the storage enclosure:

- Always install all components of the storage enclosure.
- Install hard drives in the storage enclosure so the connected host controller can identify and configure them at power up.
- Always power up the storage enclosure first, and then the server.

To power up the storage enclosure:

1. Complete server hardware installation and cabling. See the server documentation.
2. Connect the SAS cables and power cords to the storage enclosure ("[Choosing a configuration](#)" on page 20).
3. Press and hold the Power On/Standby button.
Wait and observe the system power LED and system fans. When the storage enclosure powers up, the system power LED illuminates solid green and the system fans spin to a high speed, and then spin down to a low speed.
4. Power up the servers. See the server documentation.

Power down the server

 **CAUTION:** In systems that use external data storage, be sure that the server is the first unit to be powered down and the last to be powered back up. Taking this precaution ensures that the system does not erroneously mark the drives as failed when the server is powered up.



IMPORTANT: If installing a hot-plug device, it is not necessary to power down the storage enclosure.

1. Power down any attached servers. See the server documentation.

- 2.** Press the Power On/Standby button on the storage enclosure.
Wait for the system power LED to go from green to amber.
- 3.** Disconnect the power cords.

The system is now without power.

Setup

In this section

Rack planning resources	13
Optimum environment.....	13
Rack warnings	15
Shipping contents.....	15
Rack mounting hardware kit contents.....	16
Converting rails for round-hole racks	16
Installing a storage enclosure into the rack	17
Installing hardware options	19
Installing servers.....	19
Choosing a configuration.....	20
Cabling the storage enclosure	21
Updating firmware	22

Rack planning resources

The rack resource kit ships with all HP branded 10000 series racks. For more information on the content of each resource, refer to the rack resource kit documentation.

If you intend to deploy and configure multiple servers in a single rack, refer to the white paper on high-density deployment at the HP website (<http://www.hp.com/products/servers/platforms>).

Optimum environment

When installing the storage enclosure in a rack, select a location that meets the environmental standards described in this section.

Space and airflow requirements

To allow for servicing and adequate airflow, observe the following space and airflow requirements when deciding where to install a rack:

- Leave a minimum clearance of 63.5 cm (25 in) in front of the rack.
- Leave a minimum clearance of 76.2 cm (30 in) behind the rack.
- Leave a minimum clearance of 121.9 cm (48 in) from the back of the rack to the back of another rack or row of racks.

HP storage enclosures draw in cool air through the front door and expel warm air through the rear door. Therefore, the front and rear rack doors must be adequately ventilated to allow ambient room air to enter the cabinet, and the rear door must be adequately ventilated to allow the warm air to escape from the cabinet.

 **CAUTION:** To prevent improper cooling and damage to the equipment, do not block the ventilation openings.

When a vertical space in the rack is not filled by a server or rack component, the gaps between the components cause changes in airflow through the rack and across the servers. Cover all gaps with blanking panels to maintain proper airflow.

CAUTION: Always use blanking panels to fill empty vertical spaces in the rack. This arrangement ensures proper airflow. Using a rack without blanking panels results in improper cooling that can lead to thermal damage.

The 9000 and 10000 Series racks provide proper server cooling from flow-through perforations in the front and rear doors that provide 64 percent open area for ventilation.

CAUTION: When using a Compaq branded 7000 Series rack, you must install the high airflow rack door insert [P/N 327281-B21 (42U) or P/N 157847-B21 (22U)] to provide proper front-to-back airflow and cooling.

CAUTION: If a third-party rack is used, observe the following additional requirements to ensure adequate airflow and to prevent damage to the equipment:

- Front and rear doors—If the 42U rack includes closing front and rear doors, you must allow 5,350 sq cm (830 sq in) of holes evenly distributed from top to bottom to permit adequate airflow (equivalent to the required 64 percent open area for ventilation).
- Side—The clearance between the installed rack component and the side panels of the rack must be a minimum of 7 cm (2.75 in).

Temperature requirements

To ensure continued safe and reliable equipment operation, install or position the storage enclosure in a well-ventilated, climate-controlled environment.

The maximum TMRA for most storage enclosure products is 35°C (95°F). The temperature in the room where the rack is located must not exceed 35°C (95°F).

CAUTION: To reduce the risk of damage to the equipment when installing third-party options:

- Do not permit optional equipment to impede airflow around the storage enclosure or to increase the internal rack temperature beyond the maximum allowable limits.
- Do not exceed the manufacturer's TMRA.

Power requirements

Installation of this equipment must comply with local and regional electrical regulations governing the installation of IT equipment by licensed electricians. This equipment is designed to operate in installations covered by NFPA 70, 1999 Edition (National Electric Code) and NFPA-75, 1992 (code for Protection of Electronic Computer/Data Processing Equipment). For electrical power ratings on options, refer to the product rating label or the user documentation supplied with that option.

WARNING: To reduce the risk of personal injury, fire, or damage to the equipment, do not overload the AC supply branch circuit that provides power to the rack. Consult the electrical authority having jurisdiction over wiring and installation requirements of your facility.

CAUTION: Protect the storage enclosure from power fluctuations and temporary interruptions with a regulating UPS. This device protects the hardware from damage caused by power surges and voltage spikes and keeps the storage enclosure in operation during a power failure.

When installing more than one storage enclosure, you may need to use additional power distribution devices to safely provide power to all devices. Observe the following guidelines:

- Balance the storage enclosure power load between available AC supply branch circuits.

- Do not allow the overall system AC current load to exceed 80 percent of the branch circuit AC current rating.
- Do not use common power outlet strips for this equipment.
- Provide a separate electrical circuit for each power supply in the storage enclosure.

Electrical grounding requirements

The storage enclosure must be grounded properly for proper operation and safety. In the United States, you must install the equipment in accordance with NFPA 70, 1999 Edition (National Electric Code), Article 250, as well as any local and regional building codes. In Canada, you must install the equipment in accordance with Canadian Standards Association, CSA C22.1, Canadian Electrical Code. In all other countries, you must install the equipment in accordance with any regional or national electrical wiring codes, such as the International Electrotechnical Commission (IEC) Code 364, parts 1 through 7. Furthermore, you must be sure that all power distribution devices used in the installation, such as branch wiring and receptacles, are listed or certified grounding-type devices.

Because of the high ground-leakage currents associated with multiple storage enclosure connected to the same power source, HP recommends the use of a power distribution unit (PDU) that is either permanently wired to the building's branch circuit or includes a nondetachable cord that is wired to an industrial-style plug. NEMA locking-style plugs or those complying with IEC 60309 are considered suitable for this purpose. Using common power outlet strips for the storage enclosure is not recommended.

Rack warnings

⚠ WARNING: To reduce the risk of personal injury or damage to the equipment, be sure that:

- **The leveling jacks are extended to the floor.**
- **The full weight of the rack rests on the leveling jacks.**
- **The stabilizing feet are attached to the rack if it is a single-rack installation.**
- **The racks are coupled together in multiple-rack installations.**
- **Only one component is extended at a time. A rack may become unstable if more than one component is extended for any reason.**

⚠ WARNING: To reduce the risk of personal injury or equipment damage when unloading a rack:

- **At least two people are needed to safely unload the rack from the pallet. An empty 42U rack can weigh as much as 115 kg (253 lb), can stand more than 2.1 m (7 ft) tall, and may become unstable when being moved on its casters.**
- **Never stand in front of the rack when it is rolling down the ramp from the pallet. Always handle the rack from both sides.**

Shipping contents

When unpacking the MSA60, locate the following items:

- MSA60
- Rack mounting hardware kit
- Power cords (2)
- SAS cable
- Documentation kit

Rack mounting hardware kit contents

The rack mounting hardware kit provides the required components for quick deployment in Compaq branded, HP branded, and most square- and round-hole third-party racks. The adjustable feature of the rack rails enables installation in racks with depths of 69.90 to 76.2 cm (27.52 to 30.00 in).

If you are installing the MSA60 in an M-Series rack, contact an authorized reseller to obtain an M-Series Rack Rail option kit.

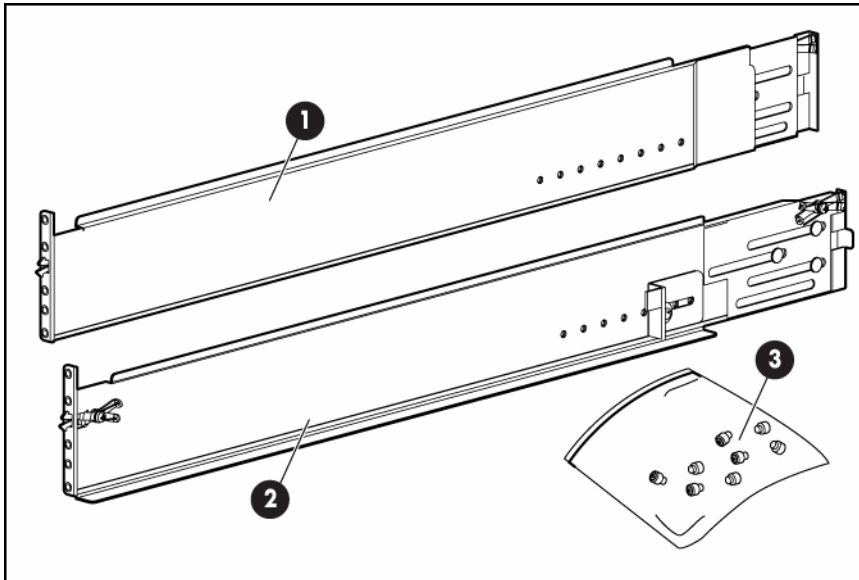

Item	Description
1	Rack rail (left)
2	Rack rail (right)
3	Pins for round-hole rack conversion (8)

In addition to these supplied items, you may need a No. 2 Phillips screwdriver.

Converting rails for round-hole racks

The rack rails ship configured for square-hole racks. To convert the rack rails for use in a round-hole rack:

1. Locate the bag of miscellaneous hardware that ships with the rack rails.
2. Locate the eight round-hole pins.

3. Use a No. 2 Phillips screwdriver to remove the standard pins from the front and back ends of the rail.

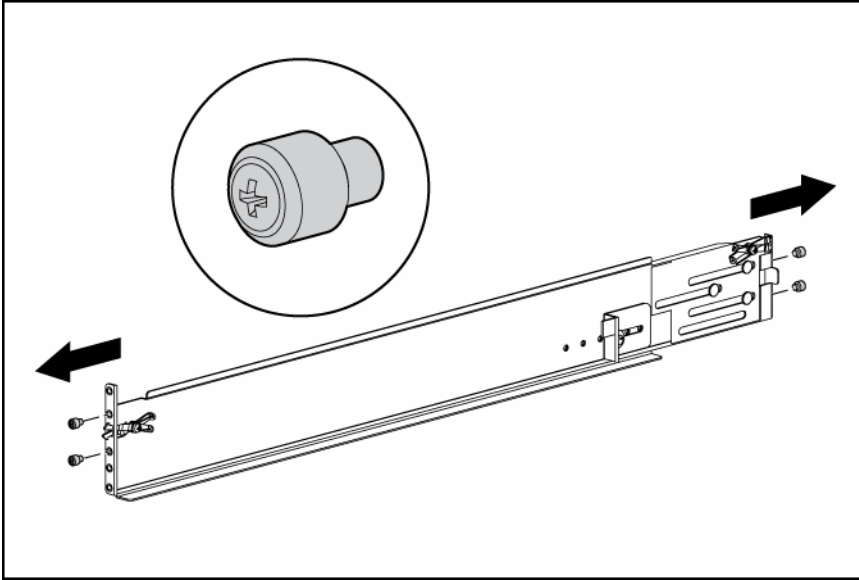

4. Install four round-hole pins into the rail.

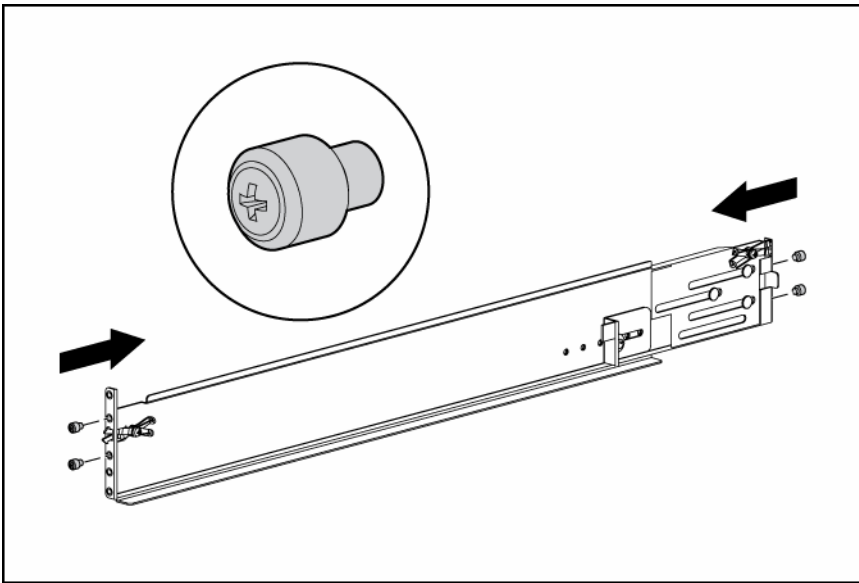

5. Repeat steps 3 and 4 for the second rail.

Installing a storage enclosure into the rack

To install the storage enclosure into the rack:

1. Secure the front end of the rails to the rack.



IMPORTANT: Do not remove the pins from the ends of the rack rails unless you are converting the rails for use in round-hole racks. These load-bearing pins are designed to fit through the holes without being removed.



IMPORTANT: Be sure that the scissor-type locking latches engage the rack fully when the pins extend through the holes marked with the template.

 **NOTE:** Identify the left (L) and right (R) rack rails by markings stamped into the sheet metal.

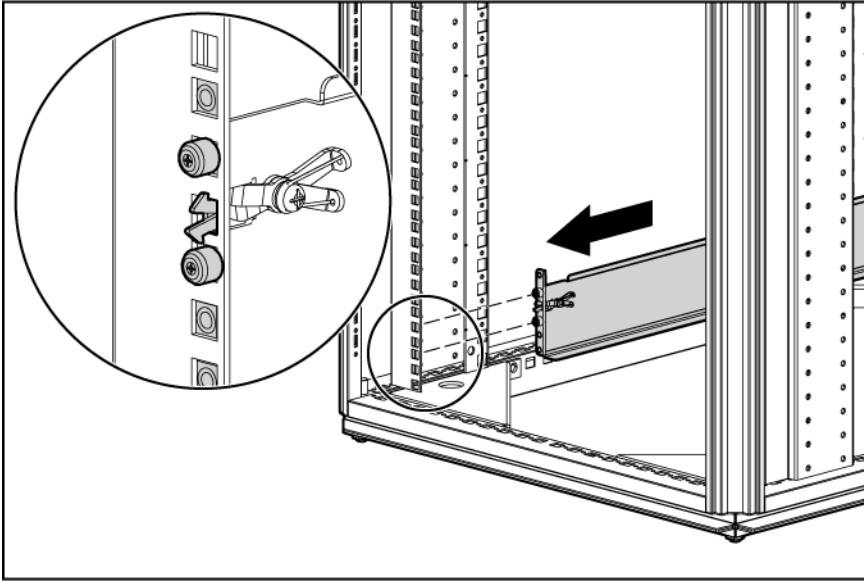

2. Secure the back end of the rails to the rack.

 **IMPORTANT:** Be sure that the scissor-type locking latches engage the rack fully when the pins extend through the holes marked with the template.

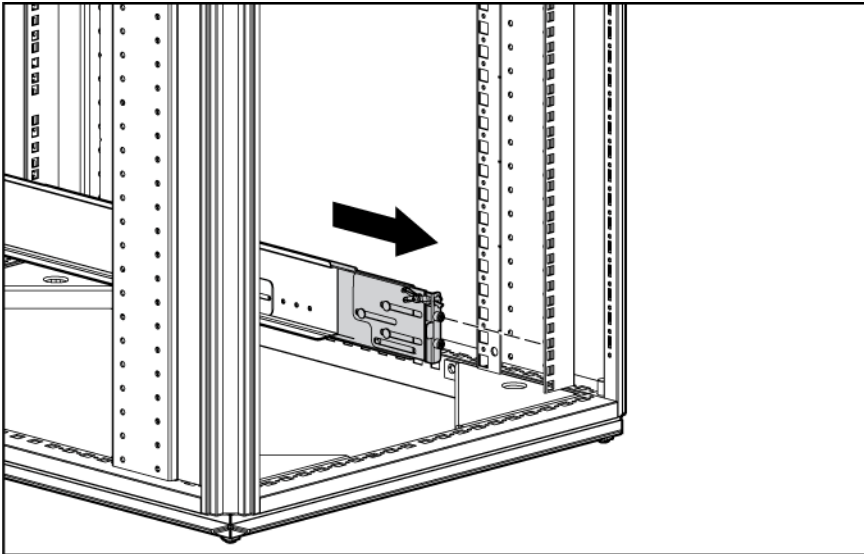

3. Slide the chassis into the rack.

4. Use the thumbscrews on the front of the chassis to secure it to the rack.

5. Use the shipping bracket to secure the storage enclosure for shipping:

 **IMPORTANT:** Use of the shipping bracket is required only when the rack is shipped with the MSA60 installed.

- a. Loosen the thumbscrew on the shipping bracket.
- b. Slide the shipping bracket forward until it engages the chassis.
- c. Tighten the thumbscrew.

If you are installing the storage enclosure into a telco rack, order the appropriate option kit at the RackSolutions website (<http://www.racksolutions.com/hp>). Follow the storage enclosure-specific instructions on the website to install the rack brackets.

Use the following information when connecting peripheral cables and power cords to the storage enclosure.

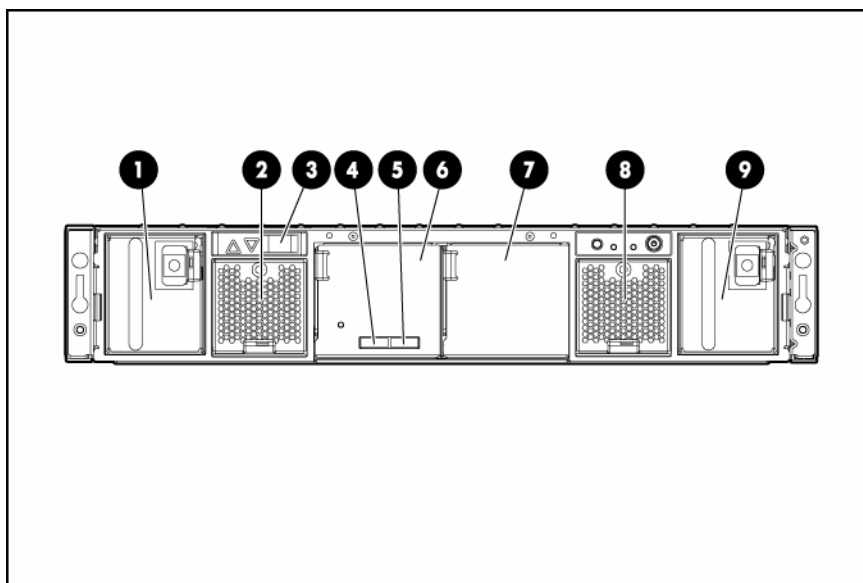

Item	Description
1	Power supply 1
2	Fan module 1
3	Dual 7-segment display board (for box ID numbering)
4	SAS in connector
5	SAS out connector
6	I/O module bay
7	For future use
8	Fan module 2
9	Power supply 2

Installing hardware options

Install any hardware options before initializing the storage enclosure. For options installation information, refer to the option documentation. For storage enclosure-specific information, refer to "Hardware Options Installation (on page 23)."

Installing servers

Install the servers in the rack directly above the storage enclosure. Refer to the server documentation.



NOTE: When installing servers, HP recommends installing all storage enclosures at the bottom of the rack. To optimize cabling access, avoid interleaving the storage enclosure and server products.

Choosing a configuration

Cable procedures vary, depending on the configuration. Choose one of the following configurations.

NOTE: The left connector of the I/O module is for input from the server. The right connector of the I/O module is for output to another storage enclosure. See the icons on the cables and enclosure to assist in proper connection.

Single-enclosure configuration

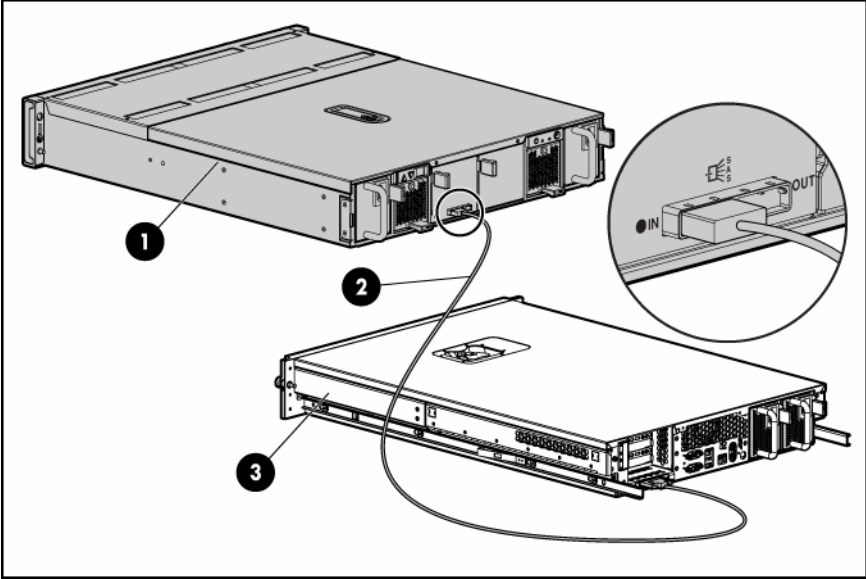

Item	Description
1	MSA60
2	SAS cable
3	Server

Cascading (1+1) configuration

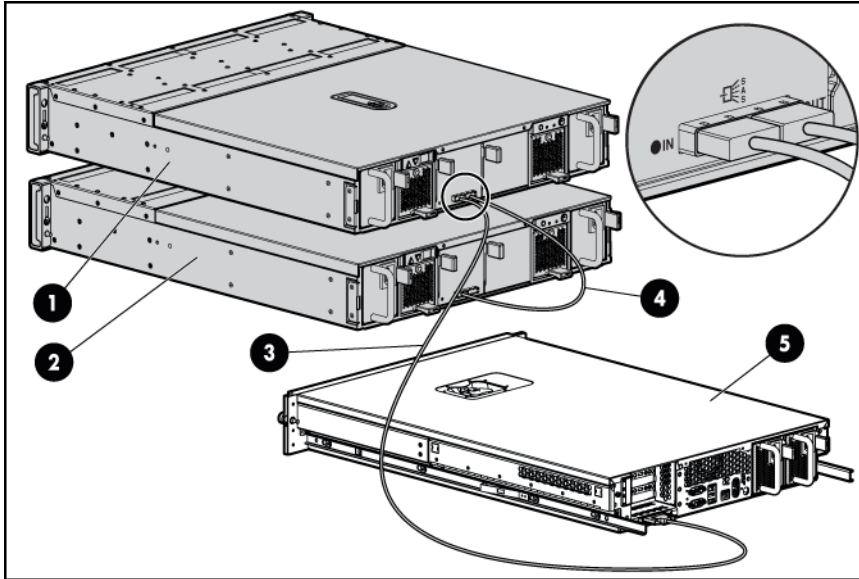

Item	Description
1	MSA60 1*
2	MSA60 2*
3	SAS cable
4	SAS cable
5	Server

* Only MSA60 enclosures can be cascaded. Do not configure with other types of storage enclosures.

Additional supported configurations:

- 1+2 configuration for a total of three cascading enclosures
- 1+3 configuration for a total of four cascading enclosures

Cabling the storage enclosure

After installing the storage enclosure in a rack, connect the SAS cables and power cords to the rear panel.

SAS cabling guidelines

Observe the following guidelines:

- Only use supported SAS cables with 3-Gb connectors.
- Always be sure that the servers attached to the storage enclosure are powered down and power cords are disconnected before connecting SAS cables.

Supported cables

A 0.5-m (20-in) SAS cable ships standard with the storage enclosure. To acquire different lengths, contact the nearest authorized HP reseller.

HP recommends using the shortest cables possible. However the maximum supported cable length that can be used between SAS ports is 6-m (19.68-ft).

For a complete list of supported cables, see the QuickSpecs on the HP website (<http://www.hp.com>).

Power cords

The power cord should be approved for use in your country. The power cord must be rated for the product and for the voltage and current marked on the electrical ratings label of the product. The voltage and current rating for the cord should be greater than the voltage and current rating marked on the product. In addition, the diameter of the wire must be a minimum of 1.00 mm² or 18 AWG, your maximum length may be up to 3.66 m (12 ft).

 **WARNING: To reduce the risk of electric shock or damage to the equipment:**

- **Do not disable the power cord grounding plug. The grounding plug is an important safety feature.**
- **Plug the power cord into a grounded (earthed) electrical outlet that is easily accessible at all times.**
- **Unplug the power cord from the power supply to disconnect power to the equipment.**
- **Do not route the power cord where it can be walked on or pinched by items placed against it. Pay particular attention to the plug, electrical outlet, and the point where the cord extends from the storage system.**

To connect AC power cords:

1. Connect the power cords to the power supplies.
2. Connect the power cords to the AC power source.

Updating firmware

To update storage enclosure firmware, see "Smart Components for ROM Flash (on page 26)," and the HP website (<http://www.hp.com/support>).

After installing hardware and powering up the storage enclosure for the first time, be sure to verify that the host controllers and drives have the latest firmware. For firmware and software updates, refer to the HP website (<http://h18004.www1.hp.com/support/files/storage/us/index.html>).

To receive proactive email support alerts such as customer advisories, updates on drivers, software, firmware, and customer replaceable components, sign up for HP Subscriber's Choice. Go to HP Subscriber's Choice on the HP website (<http://www.hp.com/go/myadvisory>), and then select the appropriate product.

Hardware options installation

In this section

Hard drive options 23

Hard drive options

The storage enclosure supports up to 12 SAS or SATA hard drives. Always populate hard drive bays starting with the lowest device number ("SAS and SATA device numbers" on page 9).

SAS and SATA hard drive guidelines

When adding hard drives to the storage enclosure, observe the following general guidelines:

- The system automatically sets all device numbers.
- If only one hard drive is used, install it in the bay with the lowest device number.
- Drives must be the same capacity to provide the greatest storage space efficiency when drives are grouped together into the same drive array.

 **NOTE:** ACU does not support mixing SAS and SATA drives in the same logical volume.

SAS or SATA hard drive

 **CAUTION:** To prevent improper cooling and thermal damage, do not operate the storage enclosure unless all bays are populated with either a component or a blank.

1. Remove the hard drive blank.

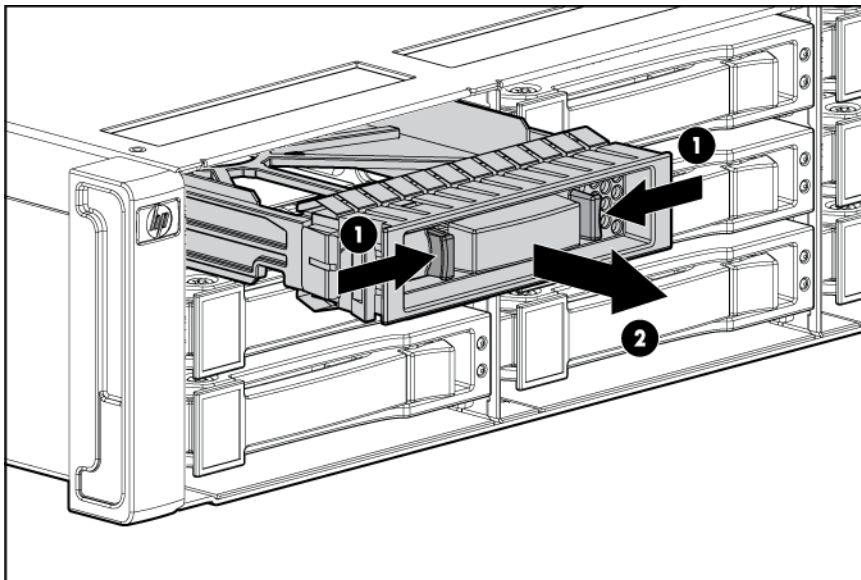

2. Prepare the hard drive.

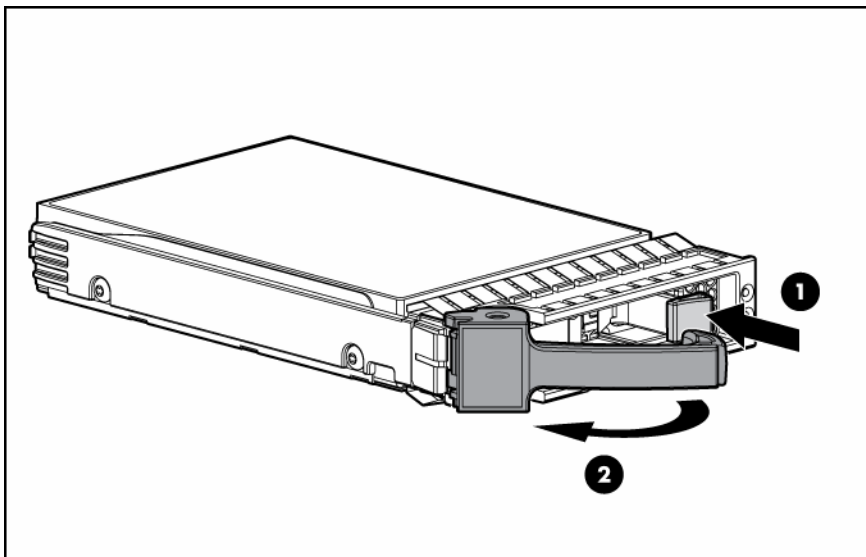

3. Install the hard drive.

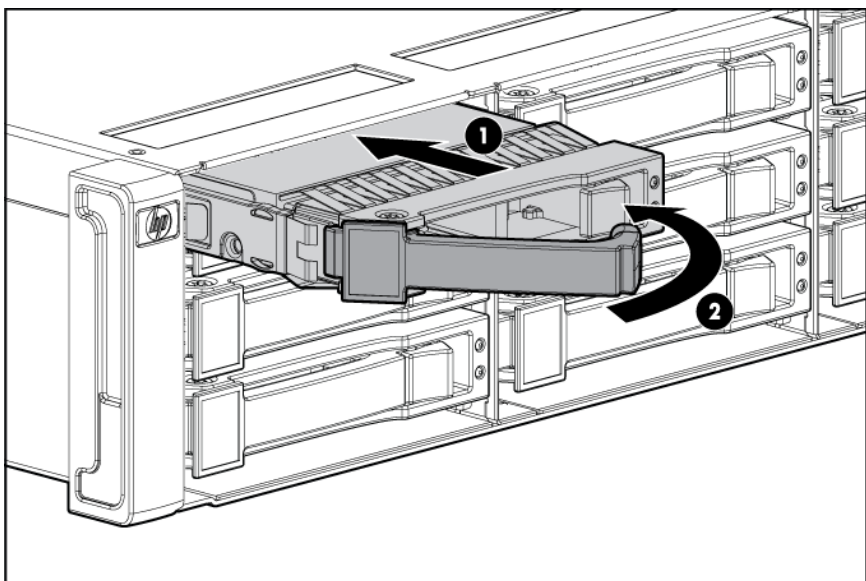

IMPORTANT: When the drive is inserted, the drive LEDs flash for 2 seconds to indicate that the drive is seated properly and receiving power.

4. Determine the status of the hard drive from the SAS and SATA hard drive LED combinations.

Configuration and utilities

In this section

Configuration tools	25
Management tools	26
Diagnostic tools	26
Remote support and analysis tools	27
Keeping the system current	27

Configuration tools

Array Configuration Utility



NOTE: ACU does not support mixing SAS and SATA drives in the same logical volume.

ACU is a browser-based utility with the following features:

- Runs as a local application or remote service
- Supports online array capacity expansion, logical drive extension, assignment of online spares, and RAID or stripe size migration
- Suggests the optimum configuration for an unconfigured system
- Provides different operating modes, enabling faster configuration or greater control over the configuration options
- Remains available any time that the server is on
- Displays on-screen tips for individual steps of a configuration procedure

For optimum performance, the minimum display settings are 800 × 600 resolution and 256 colors. Servers running Microsoft® operating systems require Internet Explorer 5.5 (with Service Pack 1) or later. For Linux servers, refer to the README.TXT file for additional browser and support information.

For more information, refer to the *Configuring Arrays on HP Smart Array Controllers Reference Guide* on the Documentation CD or the HP website (<http://www.hp.com>).

Option ROM Configuration for Arrays

Before installing an operating system, you can use the ORCA utility to create the first logical drive, assign RAID levels, and establish online spare configurations.

The utility also provides support for the following functions:

- Reconfiguring one or more logical drives
- Viewing the current logical drive configuration
- Deleting a logical drive configuration
- Setting the controller to be the boot controller

If you do not use the utility, ORCA will default to the standard configuration.

For more information regarding array controller configuration, refer to the controller user guide.

For more information regarding the default configurations that ORCA uses, refer to the *HP ROM-Based Setup Utility User Guide* on the Documentation CD.

Smart Components for ROM Flash

To update the firmware on the server, controller, hard drives, or enclosure use Smart Components. These components are available on the Firmware Maintenance CD. A more recent version of a particular component might be available on the support page of the HP website (<http://www.hp.com/support>). Components for controller and hard drive firmware updates are also available from the software and drivers page for storage products (<http://www.hp.com/support/proliantstorage>).

1. Find the most recent version of the component that you require. Components for controller firmware updates are available in offline and online formats.
2. Follow the instructions for installing the component on the server. These instructions are given with the CD and are provided on the same Web page as the component.

Follow the additional instructions that describe how to use the component to flash the ROM. These instructions are provided with each component.

Management tools

HP Systems Insight Manager

HP SIM is a web-based application that allows system administrators to accomplish normal administrative tasks from any remote location, using a web browser. HP SIM provides device management capabilities that consolidate and integrate management data from HP and third-party devices.



IMPORTANT: You must install and use HP SIM to benefit from the Pre-Failure Warranty for processors, SAS and SCSI hard drives, and memory modules.

For additional information, refer to the Management CD in the HP ProLiant Essentials Foundation Pack or the HP SIM website (<http://www.hp.com/go/hpsim>).

Management Agents

Management Agents provide the information to enable fault, performance, and configuration management. The agents allow easy manageability of the server through HP SIM software, and third-party SNMP management platforms. Management Agents are installed with every SmartStart assisted installation or can be installed through the HP PSP. The Systems Management homepage provides status and direct access to in-depth subsystem information by accessing data reported through the Management Agents. For additional information, refer to the Management CD in the HP ProLiant Essentials Foundation Pack or the HP website (<http://www.hp.com/servers/manage>).

Diagnostic tools

Integrated Management Log

The IML records hundreds of events and stores them in an easy-to-view form. The IML timestamps each event with 1-minute granularity.

You can view recorded events in the IML in several ways, including the following:

- From within HP SIM ("HP Systems Insight Manager" on page 26)

- From within Survey Utility
- From within operating system-specific IML viewers
 - For NetWare: IML Viewer
 - For Windows®: IML Viewer
 - For Linux: IML Viewer Application
- From within the iLO user interface
- From within HP Insight Diagnostics

For more information, refer to the Management CD in the HP ProLiant Essentials Foundation Pack.

Array Diagnostic Utility

The HP Array Diagnostics Utility is a web-based application that creates a report of all HP storage controllers and disk drives. This report provides vital information to assist in identifying faults or conditions that may require attention. ADU can be accessed from the SmartStart CD or downloaded from the HP website (<http://www.hp.com>).

Remote support and analysis tools

Open Services Event Manager

OSEM is a standalone tool that performs real-time reactive and proactive service event filtering, analysis, and notification. The tool gathers event data from SNMP traps or information provided over an HTTP interface and notifies an administrator or HP through SMTP and ISEE.

For more information, refer to the HP website (<http://h18000.www1.hp.com/support/svctools/>).

Keeping the system current

Change control and proactive notification

HP offers Change Control and Proactive Notification to notify customers 30 to 60 days in advance of upcoming hardware and software changes on HP commercial products.

For more information, refer to the HP website (<http://h18023.www1.hp.com/solutions/pcsolutions/pcn.html>).

Care Pack

HP Care Pack Services offer upgraded service levels to extend and expand standard product warranty with easy-to-buy, easy-to-use support packages that help you make the most of your server investments. Refer to the Care Pack website (http://www.hp.com/hps/carepack/servers/cp_proliant.html).

Troubleshooting

In this section

When the storage enclosure does not start	28
Diagnostic questions.....	29
Recognizing hard drive failure.....	29
Factors to consider before replacing hard drives.....	30
Automatic data recovery (rebuild)	31
Drive failure in a NetWare environment.....	32

When the storage enclosure does not start

If the storage enclosure does not power up:

1. Ensure that the storage enclosure is connected to a working AC source.
2. Ensure that the power source is working properly:
 - Check the status using the system power LED on the front panel ("[Front panel LEDs and buttons](#)" on page [6](#)).
 - Be sure that the Power On/Standby button was pressed firmly and held for approximately three seconds.
3. Ensure that the power supplies are working properly.
Check the status using the power supply LEDs ("[Rear panel LEDs and buttons](#)" on page [8](#)).
4. Remove the AC power cords from both enclosure power supplies and reinsert them.
5. Restart the system.



IMPORTANT: If the system does not restart, proceed to "Diagnostic questions (on page [29](#))."

6. Check the storage enclosure for the following normal power-up sequence to be sure that the system meets the minimal hardware requirements and is powered up during normal operations:
 - a. The front panel power LED turns from standby/off (amber) to on (solid green).
 - b. The system fans spin up to a high speed, and then spin down to a normal operating speed.

Diagnostic questions

Are the power supply/system fan LEDs green?

Answer	Possible Reasons	Possible Solutions
No	<ul style="list-style-type: none"> The power cords are not connected or AC power is not available. The power supply may not be inserted properly, it may have a damaged connector, or it may have failed. The system midplane may need to be replaced. 	<ul style="list-style-type: none"> Be sure that the power cord is connected to the power supply. Be sure that the power supply is undamaged and is fully seated. Be sure that all pins on connectors and components are straight. Contact an authorized service provider for assistance.
Yes	—	<p>If the system power LED is off, do the following:</p> <ol style="list-style-type: none"> Press the Power On/Standby button and hold for approximately three seconds. See Is the System Power LED Green? (on page 29)

Is the system power LED green?

Answer	Possible reasons	Possible solutions
No	<ul style="list-style-type: none"> The Power On/Standby button has not been pressed firmly or held long enough. The power supply may not be inserted properly, it may have a damaged connector, or it may have failed. The system may have experienced a short. Controller firmware may be corrupted. The system midplane and/or power button/LED assembly may need to be replaced. 	<ul style="list-style-type: none"> Firmly press the Power On/Standby button and hold for approximately three seconds. Be sure that the power supply is undamaged and is fully seated. Be sure that all pins on connectors and components are straight. Be sure that all components are fully seated. Flash the controller firmware ("Smart Components for ROM Flash" on page 26). Contact an authorized service provider for assistance.

Recognizing hard drive failure

In an HP storage enclosure, a steadily glowing Fault LED indicates that the drive has failed.

Other indications of failed hard drives:

- The amber LED on the front of a storage system is lit if drives fail. (However, this LED also illuminates when other problems occur, such as when a system fan fails, a redundant power supply fails, or the system overheats.)
- ACU represents failed drives with a distinctive icon.
- HP SIM can detect failed drives remotely across a network. (For more information about HP SIM, refer to the documentation on the Management CD.)
- ADU lists all failed drives.
- CPQONLIN identifies failed drives in a NetWare environment.

For additional information about diagnosing hard drive problems, see the *HP ProLiant Servers Troubleshooting Guide*.

△ CAUTION: Sometimes, a drive that has previously failed may seem to be operational after the system is power-cycled or (for a hot-pluggable drive) after the drive has been removed and reinserted. However, continued use of such marginal drives may eventually result in data loss. Replace the marginal drive as soon as possible.

Effects of a hard drive failure

When a hard drive fails, all logical drives that are in the same array are affected. Each logical drive in an array may be using a different fault-tolerance method, so each logical drive can be affected differently.

- RAID 0 configurations cannot tolerate drive failure. If any physical drive in the array fails, all non-fault-tolerant (RAID 0) logical drives in the same array will also fail.
- RAID 1+0 configurations can tolerate multiple drive failures as long as no failed drives are mirrored to one another (with no spares assigned).
- RAID 5 configurations can tolerate one drive failure (with no spares assigned).
- RAID 6 with ADG configurations can tolerate simultaneous failure of two drives (with no spares assigned).

Compromised fault tolerance

If more hard drives fail than the fault-tolerance method allows, fault tolerance is compromised, and the logical drive fails. In this case, all requests from the operating system are rejected with unrecoverable errors. You are likely to lose data, although it can sometimes be recovered.

One example of a situation in which compromised fault tolerance may occur is when a drive in an array fails while another drive in the array is being rebuilt. If the array has no online spare, any logical drives in this array that are configured with RAID 5 fault tolerance will fail.

Compromised fault tolerance can also be caused by non-drive problems, such as a faulty cable or temporary power loss to a storage system. In such cases, you do not need to replace the physical drives. However, you may still have lost data, especially if the system was busy at the time that the problem occurred.

Recovering from compromised fault tolerance

If fault tolerance is compromised, inserting replacement drives does not improve the condition of the logical volume. Perform the following procedure to recover data:

1. Check for loose, dirty, broken, or bent cabling and connectors on all devices.
2. Power down the storage enclosure ("[Power down the server](#)" on page 11).
3. Power up the storage enclosure ("[Power up](#)" on page 11).

In some cases, a marginal drive is operational long enough to allow backup of important files.

4. Make copies of important data, if possible.
5. Replace any failed drives.

Factors to consider before replacing hard drives

You can replace hard drives without powering down the system. However, before replacing a degraded drive:

- Open HP SIM and inspect the Error Counter window for each physical drive in the same array to confirm that no other drives have any errors. (For details, refer to the HP SIM documentation on the Management CD.)
- Be sure that the array has a current, valid backup.
- Use replacement drives that have a capacity at least as great as that of the smallest drive in the array. The controller immediately fails drives that have insufficient capacity.

To minimize the likelihood of fatal system errors when removing failed drives, take the following precautions:

- Do not remove a degraded drive if any other drive in the array is offline (the online LED is off). In this situation, removing any other drive in the array causes data loss.

Exceptions:

- When RAID 1+0 is used, drives are mirrored in pairs. Several drives can be in a failed condition simultaneously (and they can all be replaced simultaneously) without data loss, if no two failed drives belong to the same mirrored pair.
- When RAID 6 with ADG is used, two drives can fail simultaneously (and be replaced simultaneously) without data loss.
- If the offline drive is a spare, the degraded drive can be replaced.
- Do not remove a second drive from an array until the first failed or missing drive has been replaced **and** the rebuild process is complete. (The rebuild is complete when the online LED on the front of the drive stops blinking.)

Exceptions:

- In RAID 1+0 configurations, any drives that are not mirrored to other removed or failed drives can be simultaneously replaced offline without data loss.
- In RAID 6 with ADG configurations, any two drives in the array can be replaced simultaneously.

Automatic data recovery (rebuild)

When you replace a hard drive in an array, the controller uses the fault-tolerance information on the remaining drives in the array to reconstruct the missing data (the data that was originally on the replaced drive) and write it to the replacement drive. This process is called automatic data recovery, or rebuild. If fault tolerance is compromised, this data cannot be reconstructed and is likely to be permanently lost.

If another drive in the array fails while fault tolerance is unavailable during rebuild, a fatal system error may occur, and all data on the array is then lost. In exceptional cases, however, failure of another drive need not lead to a fatal system error. These exceptions include:

- Failure after activation of a spare drive
- Failure of a drive that is not mirrored to any other failed drives (in a RAID 1+0 configuration)
- Failure of a second drive in a RAID 6 with ADG configuration

Time required for a rebuild

The time required for a rebuild varies considerably, depending on several factors:

- The priority that the rebuild is given over normal I/O operations (you can change the priority setting by using ACU)
- The amount of I/O activity during the rebuild operation
- The rotational speed of the hard drives
- The availability of drive cache
- The brand, model, and age of the drives

- The amount of unused capacity on the drives
- The number of drives in the array (for RAID 5 and RAID 6 with ADG)

Allow approximately 15 minutes per gigabyte for the rebuild process to be completed. This figure is conservative, and newer drive models usually require less time to rebuild.

System performance is affected during the rebuild, and the system is unprotected against further drive failure until the rebuild has finished. Therefore, replace drives during periods of low activity when possible.

 **CAUTION:** If the Online LED of the replacement drive stops blinking and the amber Fault LED glows, or if other drive LEDs in the array go out, the replacement drive has failed and is producing unrecoverable disk errors. Remove and replace the failed replacement drive.

When automatic data recovery has finished, the Online LED of the replacement drive stops blinking and begins to glow steadily.

Failure of another drive during rebuild

If a non-correctable read error occurs on another physical drive in the array during the rebuild process, the Online LED of the replacement drive stops blinking and the rebuild abnormally terminates.

If this situation occurs, reboot the server. The system may temporarily become operational long enough to allow recovery of unsaved data. In any case, locate the faulty drive, replace it, and restore data from backup.

Drive failure in a NetWare environment

Use CPQONLIN to identify and monitor drive failure status in a NetWare environment.

Failed drives or interim recovery mode

If a drive fails and hardware fault tolerance is enabled, operation continues. Do the following:

1. Replace the drive as soon as possible.
2. Select a logical drive.
3. Press the **F3** key to monitor to the status of drive recovery.

Drive status messages include:

- **Interim Recovery:** The logical drive is operating, but a failed drive has not been replaced. Replace the drive as soon as possible.
- **Ready for Recovery:** The logical drives are queued for recovery. This status is displayed when another logical drive is already rebuilding or expanding.
- **Rebuilding:** The array is operating and rebuilding a replacement drive or an online spare, if one was assigned.
- **Logical Drive Failed:** If you have one or more logical drives that are not protected by fault tolerance in an array, the data on these logical drives will be lost. ACU shows the logical drives as FAILED. After drive replacement, any fault-tolerant logical drives rebuild. The logical drives that were not protected (FAILED) become available for data (the devices are reactivated automatically). If you have a backup of the data, restore the data now.

If you do not replace the failed drive, the only option, using ACU, is to delete logical drives. Do **not** delete logical drives that contain valid data. Doing so results in data loss.



NOTE: A failed status can occur on drives protected by fault tolerance if two or more physical drives fail concurrently.

Some status messages are available without pressing the **F3** key. For example, on the Main menu, the FAILED status appears next to the logical drive that has failed. EXPANDING and REBUILDING appear next to the array in which the activity is occurring.

Handling disk drive failures

If the controller was configured with hardware fault tolerance, complete the following steps after a disk drive failure:

1. Determine which physical drive failed. On hot-plug drives, an amber drive failure LED illuminates.
2. If the unit containing the failed drive does not support hot-plug drives, perform a normal shutdown.
3. Remove the failed drive and replace it with a drive that is of the same capacity. For hot-plug drives, after you secure the drive in the bay, the LEDs on the drive each flash once in an alternating pattern to indicate a successful connection. The online LED flashes, indicating that the controller recognized the drive replacement and began the recovery process.
4. Power up the server, if applicable.
5. The controller reconstructs the information on the new drive, based on information from the remaining physical drives in the logical drive. While reconstructing the data on hot-plug drives, the online LED flashes. When the drive rebuild is complete, the online LED is illuminated.

NetWare cannot detect a single physical drive failure when using hardware-based fault tolerance; NetWare determines that the data is still valid and accessible during the rebuilding process. However, the driver knows that a physical drive has failed. A message is printed on the console notifying the user that a physical drive is in a degraded state. CPQONLIN also shows that the drive has failed.

Regulatory compliance notices

In this section

Regulatory compliance identification numbers	34
Federal Communications Commission notice	34
Declaration of conformity for products marked with the FCC logo, United States only.....	35
Modifications.....	36
Cables	36
Canadian notice (Avis Canadien)	36
European Union regulatory notice	36
Disposal of waste equipment by users in private households in the European Union.....	37
Japanese notice	37
BSMI notice	37
Korean notice	38
Power cord statement for Japan	38

Regulatory compliance identification numbers

For the purpose of regulatory compliance certifications and identification, this product has been assigned a unique regulatory model number. The regulatory model number can be found on the product nameplate label, along with all required approval markings and information. When requesting compliance information for this product, always refer to this regulatory model number. The regulatory model number is not the marketing name or model number of the product.

Federal Communications Commission notice

Part 15 of the Federal Communications Commission (FCC) Rules and Regulations has established Radio Frequency (RF) emission limits to provide an interference-free radio frequency spectrum. Many electronic devices, including computers, generate RF energy incidental to their intended function and are, therefore, covered by these rules. These rules place computers and related peripheral devices into two classes, A and B, depending upon their intended installation. Class A devices are those that may reasonably be expected to be installed in a business or commercial environment. Class B devices are those that may reasonably be expected to be installed in a residential environment (for example, personal computers). The FCC requires devices in both classes to bear a label indicating the interference potential of the device as well as additional operating instructions for the user.

FCC rating label

The FCC rating label on the device shows the classification (A or B) of the equipment. Class B devices have an FCC logo or ID on the label. Class A devices do not have an FCC logo or ID on the label. After you determine the class of the device, refer to the corresponding statement.

Class A equipment

This equipment has been tested and found to comply with the limits for a Class A digital device, pursuant to Part 15 of the FCC Rules. These limits are designed to provide reasonable protection against harmful interference when the equipment is operated in a commercial environment. This equipment generates, uses, and can radiate radio frequency energy and, if not installed and used in accordance with the instructions, may cause harmful interference to radio communications. Operation of this equipment in a residential area is likely to cause harmful interference, in which case the user will be required to correct the interference at personal expense.

Class B equipment

This equipment has been tested and found to comply with the limits for a Class B digital device, pursuant to Part 15 of the FCC Rules. These limits are designed to provide reasonable protection against harmful interference in a residential installation. This equipment generates, uses, and can radiate radio frequency energy and, if not installed and used in accordance with the instructions, may cause harmful interference to radio communications. However, there is no guarantee that interference will not occur in a particular installation. If this equipment does cause harmful interference to radio or television reception, which can be determined by turning the equipment off and on, the user is encouraged to try to correct the interference by one or more of the following measures:

- Reorient or relocate the receiving antenna.
- Increase the separation between the equipment and receiver.
- Connect the equipment into an outlet on a circuit that is different from that to which the receiver is connected.
- Consult the dealer or an experienced radio or television technician for help.

Declaration of conformity for products marked with the FCC logo, United States only

This device complies with Part 15 of the FCC Rules. Operation is subject to the following two conditions: (1) this device may not cause harmful interference, and (2) this device must accept any interference received, including interference that may cause undesired operation.

For questions regarding this product, contact us by mail or telephone:

- Hewlett-Packard Company
P. O. Box 692000, Mail Stop 530113
Houston, Texas 77269-2000
- 1-800-HP-INVENT (1-800-474-6836). (For continuous quality improvement, calls may be recorded or monitored.)

For questions regarding this FCC declaration, contact us by mail or telephone:

- Hewlett-Packard Company
P. O. Box 692000, Mail Stop 510101
Houston, Texas 77269-2000
- 1-281-514-3333

To identify this product, refer to the part, series, or model number found on the product.

Modifications

The FCC requires the user to be notified that any changes or modifications made to this device that are not expressly approved by Hewlett-Packard Company may void the user's authority to operate the equipment.

Cables

Connections to this device must be made with shielded cables with metallic RFI/EMI connector hoods in order to maintain compliance with FCC Rules and Regulations.

Canadian notice (Avis Canadien)

Class A equipment

This Class A digital apparatus meets all requirements of the Canadian Interference-Causing Equipment Regulations.

Cet appareil numérique de la classe A respecte toutes les exigences du Règlement sur le matériel brouilleur du Canada.

Class B equipment

This Class B digital apparatus meets all requirements of the Canadian Interference-Causing Equipment Regulations.

Cet appareil numérique de la classe B respecte toutes les exigences du Règlement sur le matériel brouilleur du Canada.

European Union regulatory notice

This product complies with the following EU Directives:

- Low Voltage Directive 73/23/EEC
- EMC Directive 89/336/EEC

Compliance with these directives implies conformity to applicable harmonized European standards (European Norms) which are listed on the EU Declaration of Conformity issued by Hewlett-Packard for this product or product family.

This compliance is indicated by the following conformity marking placed on the product:



This marking is valid for non-Telecom products and EU harmonized Telecom products (e.g. Bluetooth).



This marking is valid for EU non-harmonized Telecom products.

*Notified body number (used only if applicable—refer to the product label)

Hewlett-Packard GmbH, HQ-TRE, Herrenberger Strasse 140, 71034 Boeblingen, Germany

Disposal of waste equipment by users in private households in the European Union



This symbol on the product or on its packaging indicates that this product must not be disposed of with your other household waste. Instead, it is your responsibility to dispose of your waste equipment by handing it over to a designated collection point for the recycling of waste electrical and electronic equipment. The separate collection and recycling of your waste equipment at the time of disposal will help to conserve natural resources and ensure that it is recycled in a manner that protects human health and the environment. For more information about where you can drop off your waste equipment for recycling, please contact your local city office, your household waste disposal service or the shop where you purchased the product.

Japanese notice

ご使用になっている装置にVCCIマークが付いていましたら、次の説明文をお読み下さい。

この装置は、情報処理装置等電波障害自主規制協議会（VCCI）の基準に基づくクラスB情報技術装置です。この装置は、家庭環境で使用することを目的としていますが、この装置がラジオやテレビジョン受信機に近接して使用されると、受信障害を引き起こすことがあります。取扱説明書に従って正しい取り扱いをして下さい。

VCCIマークが付いていない場合には、次の点にご注意下さい。

この装置は、情報処理装置等電波障害自主規制協議会（VCCI）の基準に基づくクラスA情報技術装置です。この装置を家庭環境で使用すると電波妨害を引き起こすことがあります。この場合には使用者が適切な対策を講ずるよう要求されることがあります。

BSMI notice

警告使用者:

這是甲類的資訊產品，在居住的環境中使用時，可能會造成射頻干擾，在這種情況下，使用者會被要求採取某些適當的對策。

Korean notice

Class A equipment

A급 기기 (업무용 정보통신기기)

이 기기는 업무용으로 전자파적합등록을 한 기기이오니 판매자 또는 사용자는 이 점을 주의하시기 바라며, 만약 잘못판매 또는 구입하였을 때에는 가정용으로 교환하시기 바랍니다.

Class B equipment

B급 기기 (가정용 정보통신기기)

이 기기는 가정용으로 전자파적합등록을 한 기기로서 주거지역에서는 물론 모든지역에서 사용할 수 있습니다.

Power cord statement for Japan

製品には、同梱された電源コードをお使い下さい。
同梱された電源コードは、他の製品では使用出来ません。

Electrostatic discharge

In this section

Preventing electrostatic discharge.....	39
Grounding methods to prevent electrostatic discharge	39

Preventing electrostatic discharge

To prevent damaging the system, be aware of the precautions you need to follow when setting up the system or handling parts. A discharge of static electricity from a finger or other conductor may damage system boards or other static-sensitive devices. This type of damage may reduce the life expectancy of the device.

To prevent electrostatic damage:

- Avoid hand contact by transporting and storing products in static-safe containers.
- Keep electrostatic-sensitive parts in their containers until they arrive at static-free workstations.
- Place parts on a grounded surface before removing them from their containers.
- Avoid touching pins, leads, or circuitry.
- Always be properly grounded when touching a static-sensitive component or assembly.

Grounding methods to prevent electrostatic discharge

Several methods are used for grounding. Use one or more of the following methods when handling or installing electrostatic-sensitive parts:

- Use a wrist strap connected by a ground cord to a grounded workstation or computer chassis. Wrist straps are flexible straps with a minimum of 1 megohm ± 10 percent resistance in the ground cords. To provide proper ground, wear the strap snug against the skin.
- Use heel straps, toe straps, or boot straps at standing workstations. Wear the straps on both feet when standing on conductive floors or dissipating floor mats.
- Use conductive field service tools.
- Use a portable field service kit with a folding static-dissipating work mat.

If you do not have any of the suggested equipment for proper grounding, have an authorized reseller install the part.

For more information on static electricity or assistance with product installation, contact an authorized reseller.

Specifications

In this section

Environmental specifications	40
Storage enclosure specifications	40

Environmental specifications

Specification	Value
Temperature range	
Operating*	10°C to 35°C (50°F to 95°F) Maximum rate of change is 10° C/hr (18° F/hr)
Storage	-30°C to 60°C (-22°F to 140°F) Maximum rate of change is 20° C/hr (36° F/hr)
Relative humidity**	
Operating	10% to 90% relative humidity (Rh), 28° C (82.4° F) maximum wet bulb temperature, non-condensing
Storage	5% to 95% relative humidity (Rh), 38.7° C (101.66° F) maximum wet bulb temperature, non-condensing
Altitude ‡	
Operating	3048 m (10,000 ft) This value may be limited by the type and number of options installed.
Non-operating	9144 m (30,000 ft)

* Temperature ratings shown are for sea level. An altitude derating of 1°C per 300 m (1.8°F per 1,000 ft) to 3048 m (10,000 ft) is applicable. No direct sunlight allowed. The upper limit may be limited by the type and number of options installed.

** Storage maximum humidity of 95% is based on a maximum temperature of 45°C (113°F). Altitude maximum for storage corresponds to a pressure minimum of 70 KPa.

‡ Maximum allowable altitude change rate is 457 m/min (1500 ft/min).

Storage enclosure specifications

Specification	Value
Height	8.8 cm (3.47 in)
Depth	59 cm (23.25 in)
Width	44.80 cm (17.64 in)
Weight (maximum)	24.6 kg (54 lb)
Weight (no drives installed)	15.42 kg (34 lb)

Technical support

In this section

Before you contact HP.....	41
HP contact information.....	41
Customer Self Repair	41

Before you contact HP

Be sure to have the following information available before you call HP:

- Technical support registration number (if applicable)
- Product serial number
- Product model name and number
- Applicable error messages
- Add-on boards or hardware
- Third-party hardware or software
- Operating system type and revision level

HP contact information

For the name of the nearest HP authorized reseller:

- In the United States, see the HP US service locator webpage (http://www.hp.com/service_locator).
- In other locations, see the Contact HP worldwide (in English) webpage (<http://welcome.hp.com/country/us/en/wwcontact.html>).

For HP technical support:

- In the United States, for contact options see the Contact HP United States webpage (http://welcome.hp.com/country/us/en/contact_us.html). To contact HP by phone:
 - Call 1-800-HP-INVENT (1-800-474-6836). This service is available 24 hours a day, 7 days a week. For continuous quality improvement, calls may be recorded or monitored.
 - If you have purchased a Care Pack (service upgrade), call 1-800-633-3600. For more information about Care Packs, refer to the HP website (<http://www.hp.com>).
- In other locations, see the Contact HP worldwide (in English) webpage (<http://welcome.hp.com/country/us/en/wwcontact.html>).

Customer Self Repair

HP products are designed with many Customer Self Repair (CSR) parts to minimize repair time and allow for greater flexibility in performing defective parts replacement. If during the diagnosis period HP (or HP service providers or service partners) identifies that the repair can be accomplished by the use of a CSR part, HP will ship that part directly to you for replacement. There are two categories of CSR parts:

- **Mandatory**—Parts for which customer self repair is mandatory. If you request HP to replace these parts, you will be charged for the travel and labor costs of this service.
- **Optional**—Parts for which customer self repair is optional. These parts are also designed for customer self repair. If, however, you require that HP replace them for you, there may or may not be additional charges, depending on the type of warranty service designated for your product.

NOTE: Some HP parts are not designed for customer self repair. In order to satisfy the customer warranty, HP requires that an authorized service provider replace the part. These parts are identified as "No" in the Illustrated Parts Catalog.

Based on availability and where geography permits, CSR parts will be shipped for next business day delivery. Same day or four-hour delivery may be offered at an additional charge where geography permits. If assistance is required, you can call the HP Technical Support Center and a technician will help you over the telephone. HP specifies in the materials shipped with a replacement CSR part whether a defective part must be returned to HP. In cases where it is required to return the defective part to HP, you must ship the defective part back to HP within a defined period of time, normally five (5) business days. The defective part must be returned with the associated documentation in the provided shipping material. Failure to return the defective part may result in HP billing you for the replacement. With a customer self repair, HP will pay all shipping and part return costs and determine the courier/carrier to be used.

For more information about HP's Customer Self Repair program, contact your local service provider. For the North American program, refer to the HP website (<http://www.hp.com/go/selfrepair>).

Réparation par le client (CSR)

Les produits HP comportent de nombreuses pièces CSR (Customer Self Repair = réparation par le client) afin de minimiser les délais de réparation et faciliter le remplacement des pièces défectueuses. Si pendant la période de diagnostic, HP (ou ses partenaires ou mainteneurs agréés) détermine que la réparation peut être effectuée à l'aide d'une pièce CSR, HP vous l'envoie directement. Il existe deux catégories de pièces CSR:

- **Obligatoire** - Pièces pour lesquelles la réparation par le client est obligatoire. Si vous demandez à HP de remplacer ces pièces, les coûts de déplacement et main d'œuvre du service vous seront facturés.
- **Facultatif** - Pièces pour lesquelles la réparation par le client est facultative. Ces pièces sont également conçues pour permettre au client d'effectuer lui-même la réparation. Toutefois, si vous demandez à HP de remplacer ces pièces, l'intervention peut ou non vous être facturée, selon le type de garantie applicable à votre produit.

REMARQUE: Certaines pièces HP ne sont pas conçues pour permettre au client d'effectuer lui-même la réparation. Pour que la garantie puisse s'appliquer, HP exige que le remplacement de la pièce soit effectué par un Mainteneur Agréé. Ces pièces sont identifiées par la mention "Non" dans le Catalogue illustré.

Les pièces CSR sont livrées le jour ouvré suivant, dans la limite des stocks disponibles et selon votre situation géographique. Si votre situation géographique le permet et que vous demandez une livraison le jour même ou dans les 4 heures, celle-ci vous sera facturée. Pour bénéficier d'une assistance téléphonique, appelez le Centre d'assistance technique HP. Dans les documents envoyés avec la pièce de rechange CSR, HP précise s'il est nécessaire de lui retourner la pièce défectueuse. Si c'est le cas, vous devez le faire dans le délai indiqué, généralement cinq (5) jours ouvrés. La pièce et sa documentation doivent être retournées dans l'emballage fourni. Si vous ne retournez pas la pièce défectueuse, HP se réserve le droit de vous facturer les coûts de remplacement. Dans le cas d'une pièce CSR, HP supporte l'ensemble des frais d'expédition et de retour, et détermine la société de courses ou le transporteur à utiliser.

Pour plus d'informations sur le programme CSR de HP, contactez votre Mainteneur Agrée local. Pour plus d'informations sur ce programme en Amérique du Nord, consultez le site Web HP (<http://www.hp.com/go/selfrepair>).

Riparazione da parte del cliente

Per abbreviare i tempi di riparazione e garantire una maggiore flessibilità nella sostituzione di parti difettose, i prodotti HP sono realizzati con numerosi componenti che possono essere riparati direttamente dal cliente (CSR, Customer Self Repair). Se in fase di diagnostica HP (o un centro di servizi o di assistenza HP) identifica il guasto come riparabile mediante un ricambio CSR, HP lo spedisce direttamente al cliente per la sostituzione. Vi sono due categorie di parti CSR:

- **Obbligatorie** – Parti che devono essere necessariamente riparate dal cliente. Se il cliente ne affida la riparazione ad HP, deve sostenere le spese di spedizione e di manodopera per il servizio.
- **Opzionali** – Parti la cui riparazione da parte del cliente è facoltativa. Si tratta comunque di componenti progettati per questo scopo. Se tuttavia il cliente ne richiede la sostituzione ad HP, potrebbe dover sostenere spese aggiuntive a seconda del tipo di garanzia previsto per il prodotto.

NOTA: alcuni componenti HP non sono progettati per la riparazione da parte del cliente. Per rispettare la garanzia, HP richiede che queste parti siano sostituite da un centro di assistenza autorizzato. Tali parti sono identificate da un "No" nel Catalogo illustrato dei componenti.

In base alla disponibilità e alla località geografica, le parti CSR vengono spedite con consegna entro il giorno lavorativo seguente. La consegna nel giorno stesso o entro quattro ore è offerta con un supplemento di costo solo in alcune zone. In caso di necessità si può richiedere l'assistenza telefonica di un addetto del centro di supporto tecnico HP. Nel materiale fornito con una parte di ricambio CSR, HP specifica se il cliente deve restituire dei componenti. Qualora sia richiesta la resa ad HP del componente difettoso, lo si deve spedire ad HP entro un determinato periodo di tempo, generalmente cinque (5) giorni lavorativi. Il componente difettoso deve essere restituito con la documentazione associata nell'imballo di spedizione fornito. La mancata restituzione del componente può comportare la fatturazione del ricambio da parte di HP. Nel caso di riparazione da parte del cliente, HP sostiene tutte le spese di spedizione e resa e sceglie il corriere/vettore da utilizzare.

Per ulteriori informazioni sul programma CSR di HP contattare il centro di assistenza di zona. Per il programma in Nord America fare riferimento al sito Web **HP** (<http://www.hp.com/go/selfrepair>).

Customer Self Repair

HP Produkte enthalten viele CSR-Teile (Customer Self Repair), um Reparaturzeiten zu minimieren und höhere Flexibilität beim Austausch defekter Bauteile zu ermöglichen. Wenn HP (oder ein HP Servicepartner) bei der Diagnose feststellt, dass das Produkt mithilfe eines CSR-Teils repariert werden kann, sendet Ihnen HP dieses Bauteil zum Austausch direkt zu. CSR-Teile werden in zwei Kategorien unterteilt:

- **Zwingend** – Teile, für die das Customer Self Repair-Verfahren zwingend vorgegeben ist. Wenn Sie den Austausch dieser Teile von HP vornehmen lassen, werden Ihnen die Anfahrt- und Arbeitskosten für diesen Service berechnet.
- **Optional** – Teile, für die das Customer Self Repair-Verfahren optional ist. Diese Teile sind auch für Customer Self Repair ausgelegt. Wenn Sie jedoch den Austausch dieser Teile von HP vornehmen lassen möchten, können bei diesem Service je nach den für Ihr Produkt vorgesehenen Garantiebedingungen zusätzliche Kosten anfallen.

HINWEIS: Einige Teile sind nicht für Customer Self Repair ausgelegt. Um den Garantieanspruch des Kunden zu erfüllen, muss das Teil von einem HP Servicepartner ersetzt werden. Im illustrierten Teilekatalog sind diese Teile mit „No“ bzw. „Nein“ gekennzeichnet.

CSR-Teile werden abhängig von der Verfügbarkeit und vom Lieferziel am folgenden Geschäftstag geliefert. Für bestimmte Standorte ist eine Lieferung am selben Tag oder innerhalb von vier Stunden gegen einen Aufpreis verfügbar. Wenn Sie Hilfe benötigen, können Sie das HP technische Support Center anrufen und sich von einem Mitarbeiter per Telefon helfen lassen. Den Materialien, die mit einem CSR-Ersatzteil geliefert werden, können Sie entnehmen, ob das defekte Teil an HP zurückgeschickt werden muss. Wenn es erforderlich ist, das defekte Teil an HP zurückzuschicken, müssen Sie dies innerhalb eines vorgegebenen Zeitraums tun, in der Regel innerhalb von fünf (5) Geschäftstagen. Das defekte Teil muss mit der zugehörigen Dokumentation in der Verpackung zurückgeschickt werden, die im Lieferumfang enthalten ist. Wenn Sie das defekte Teil nicht zurückschicken, kann HP Ihnen das Ersatzteil in Rechnung stellen. Im Falle von Customer Self Repair kommt HP für alle Kosten für die Lieferung und Rücksendung auf und bestimmt den Kurier-/Frachtdienst.

Weitere Informationen über das HP Customer Self Repair Programm erhalten Sie von Ihrem Servicepartner vor Ort. Informationen über das CSR-Programm in Nordamerika finden Sie auf der HP Website unter (<http://www.hp.com/go/selfrepair>).

Reparaciones del propio cliente

Los productos de HP incluyen muchos componentes que el propio usuario puede reemplazar (*Customer Self Repair*, CSR) para minimizar el tiempo de reparación y ofrecer una mayor flexibilidad a la hora de realizar sustituciones de componentes defectuosos. Si, durante la fase de diagnóstico, HP (o los proveedores o socios de servicio de HP) identifica que una reparación puede llevarse a cabo mediante el uso de un componente CSR, HP le enviará dicho componente directamente para que realice su sustitución. Los componentes CSR se clasifican en dos categorías:

- **Obligatorio:** componentes para los que la reparación por parte del usuario es obligatoria. Si solicita a HP que realice la sustitución de estos componentes, tendrá que hacerse cargo de los gastos de desplazamiento y de mano de obra de dicho servicio.
- **Opcional:** componentes para los que la reparación por parte del usuario es opcional. Estos componentes también están diseñados para que puedan ser reparados por el usuario. Sin embargo, si precisa que HP realice su sustitución, puede o no conllevar costes adicionales, dependiendo del tipo de servicio de garantía correspondiente al producto.

NOTA: Algunos componentes no están diseñados para que puedan ser reparados por el usuario. Para que el usuario haga valer su garantía, HP pone como condición que un proveedor de servicios autorizado realice la sustitución de estos componentes. Dichos componentes se identifican con la palabra "No" en el catálogo ilustrado de componentes.

Según la disponibilidad y la situación geográfica, los componentes CSR se enviarán para que lleguen a su destino al siguiente día laborable. Si la situación geográfica lo permite, se puede solicitar la entrega en el mismo día o en cuatro horas con un coste adicional. Si precisa asistencia técnica, puede llamar al Centro de asistencia técnica de HP y recibirá ayuda telefónica por parte de un técnico. Con el envío de materiales para la sustitución de componentes CSR, HP especificará si los componentes defectuosos deberán devolverse a HP. En aquellos casos en los que sea necesario devolver algún componente a HP, deberá hacerlo en el periodo de tiempo especificado, normalmente cinco días laborables. Los componentes defectuosos deberán devolverse con toda la documentación relacionada y con el embalaje de envío. Si no enviara el componente defectuoso requerido, HP podrá cobrarle por el de sustitución. En el caso de todas sustituciones que lleve a cabo el cliente, HP se hará cargo de todos los gastos de envío y devolución de componentes y escogerá la empresa de transporte que se utilice para dicho servicio.

Para obtener más información acerca del programa de Reparaciones del propio cliente de HP, póngase en contacto con su proveedor de servicios local. Si está interesado en el programa para Norteamérica, visite la página web de HP siguiente (<http://www.hp.com/go/selfrepair>).

Customer Self Repair

Veel onderdelen in HP producten zijn door de klant zelf te repareren, waardoor de reparatieduur tot een minimum beperkt kan blijven en de flexibiliteit in het vervangen van defecte onderdelen groter is. Deze onderdelen worden CSR-onderdelen (Customer Self Repair) genoemd. Als HP (of een HP Service Partner) bij de diagnose vaststelt dat de reparatie kan worden uitgevoerd met een CSR-onderdeel, verzendt HP dat onderdeel rechtstreeks naar u, zodat u het defecte onderdeel daarmee kunt vervangen. Er zijn twee categorieën CSR-onderdelen:

- **Verplicht:** Onderdelen waarvoor reparatie door de klant verplicht is. Als u HP verzoekt deze onderdelen voor u te vervangen, worden u voor deze service reiskosten en arbeidsloon in rekening gebracht.
- **Optioneel:** Onderdelen waarvoor reparatie door de klant optioneel is. Ook deze onderdelen zijn ontworpen voor reparatie door de klant. Als u echter HP verzoekt deze onderdelen voor u te vervangen, kunnen daarvoor extra kosten in rekening worden gebracht, afhankelijk van het type garanteservice voor het product.

OPMERKING: Sommige HP onderdelen zijn niet ontwikkeld voor reparatie door de klant. In verband met de garantievoorwaarden moet het onderdeel door een geautoriseerde Service Partner worden vervangen. Deze onderdelen worden in de geïllustreerde onderdelencatalogus aangemerkt met "Nee".

Afhankelijk van de leverbaarheid en de locatie worden CSR-onderdelen verzonden voor levering op de eerstvolgende werkdag. Levering op dezelfde dag of binnen vier uur kan tegen meerkosten worden aangeboden, indien dit mogelijk is gezien de locatie. Indien assistentie gewenst is, belt u een HP Service Partner om via de telefoon technische ondersteuning te ontvangen. HP vermeldt in de documentatie bij het vervangende CSR-onderdeel of het defecte onderdeel aan HP moet worden geretourneerd. Als het defecte onderdeel aan HP moet worden teruggezonden, moet u het defecte onderdeel binnen een bepaalde periode, gewoonlijk vijf (5) werkdagen, retourneren aan HP. Het defecte onderdeel moet met de bijbehorende documentatie worden geretourneerd in het meegeleverde verpakkingsmateriaal. Als u het defecte onderdeel niet terugzendt, kan HP u voor het vervangende onderdeel kosten in rekening brengen. Bij reparatie door de klant betaalt HP alle verzendkosten voor het vervangende en geretourneerde onderdeel en kiest HP zelf welke koerier/transportonderneming hiervoor wordt gebruikt.

Neem contact op met een Service Partner voor meer informatie over het Customer Self Repair programma van HP. Informatie over Service Partners vindt u op de **HP website** (<http://www.hp.nl/services/servicepartners>).

Reparo feito pelo cliente

Os produtos da HP são projetados com muitas peças para reparo feito pelo cliente (CSR) de modo a minimizar o tempo de reparo e permitir maior flexibilidade na substituição de peças com defeito. Se, durante o período de diagnóstico, a HP (ou fornecedores/parceiros de serviço da HP) concluir que o reparo pode ser efetuado pelo uso de uma peça CSR, a peça de reposição será enviada diretamente ao cliente. Existem duas categorias de peças CSR:

- **Obrigatória** – Peças cujo reparo feito pelo cliente é obrigatório. Se desejar que a HP substitua essas peças, serão cobradas as despesas de transporte e mão-de-obra do serviço.
- **Opcional** – Peças cujo reparo feito pelo cliente é opcional. Essas peças também são projetadas para o reparo feito pelo cliente. No entanto, se desejar que a HP as substitua, pode haver ou não a cobrança de taxa adicional, dependendo do tipo de serviço de garantia destinado ao produto.

OBSERVAÇÃO: Algumas peças da HP não são projetadas para o reparo feito pelo cliente. A fim de cumprir a garantia do cliente, a HP exige que um técnico autorizado substitua a peça. Essas peças estão identificadas com a marca "No" (Não), no catálogo de peças ilustrado.

Conforme a disponibilidade e o local geográfico, as peças CSR serão enviadas no primeiro dia útil após o pedido. Onde as condições geográficas permitirem, a entrega no mesmo dia ou em quatro horas pode ser feita mediante uma taxa adicional. Se precisar de auxílio, entre em contato com o Centro de suporte técnico da HP para que um técnico o ajude por telefone. A HP especifica nos materiais fornecidos com a peça CSR de reposição se a peça com defeito deve ser devolvida à HP. Nos casos em que isso for necessário, é preciso enviar a peça com defeito à HP dentro do período determinado, normalmente cinco (5) dias úteis. A peça com defeito deve ser enviada com a documentação correspondente no material de transporte fornecido. Caso não o faça, a HP poderá cobrar a reposição. Para as peças de reparo feito pelo cliente, a HP paga todas as despesas de transporte e de devolução da peça e determina a transportadora/serviço postal a ser utilizado.

Para obter mais informações sobre o programa de reparo feito pelo cliente da HP, entre em contato com o fornecedor de serviços local. Para o programa norte-americano, visite o site da HP (<http://www.hp.com/go/selfrepair>).

顧客自己修理保証サービス

修理時間を短縮し、故障部品の交換における高い柔軟性を確保するために、HP製品には多数の顧客自己修理（CSR）部品があります。診断の際に、CSR部品を使用すれば修理ができるとHP（HPまたはHP正規保守代理店）が判断した場合、HPはその部品を直接、お客様に発送し、お客様に交換していただきます。CSR部品には以下の2通りがあります。

- **必須** - 顧客自己修理が必須の部品。当該部品について、もしもお客様がHPに交換作業を依頼される場合には、その修理サービスに関する交通費および人件費がお客様に請求されます。
- **任意** - 顧客自己修理が任意である部品。この部品も顧客自己修理用です。当該部品について、もしもお客様がHPに交換作業を依頼される場合には、お買い上げの製品に適用される保証サービス内容の範囲内においては、別途費用を負担していただくことなく保証サービスを受けることができます。

注：HP製品の一部の部品は、顧客自己修理用ではありません。製品の保証を継続するためには、HPまたはHP正規保守代理店による交換作業が必須となります。部品カタログには、当該部品が顧客自己修理除外品である旨が記載されています。

部品供給が可能な場合、地域によっては、CSR部品を翌営業日に届くように発送します。また、地域によっては、追加費用を負担いただくことにより同日または4時間以内に届くように発送することも可能な場合があります。サポートが必要なときは、HPの修理受付窓口へ電話していただければ、技術者が電話でアドバイスします。交換用のCSR部品または同梱物には、故障部品をHPに返送する必要があるかどうかが表示されています。故障部品をHPに返送する必要がある場合は、指定期限内（通常は5営業日以内）に故障部品をHPに返送してください。故障部品を返送する場合は、届いた時の梱包箱に関連書類とともに入れてください。故障部品を返送しない場合、HPから部品費用が請求されます。顧客自己修理の際には、HPは送料および部品返送費を全額負担し、使用する宅配便会社や運送会社を指定します。

客户自行维修

HP 产品提供许多客户自行维修 (CSR) 部件，以尽可能缩短维修时间和在更换缺陷部件方面提供更大的灵活性。如果在诊断期间 HP（或 HP 服务提供商或服务合作伙伴）确定可以通过使用 CSR 部件完成维修，HP 将直接把该部件发送给您进行更换。有两类 CSR 部件：

- **强制性的** — 要求客户必须自行维修的部件。如果您请求 HP 更换这些部件，则必须为该服务支付差旅费和人工费用。
- **可选的** — 客户可以选择是否自行维修的部件。这些部件也是为客户自行维修设计的。不过，如果您要求 HP 为您更换这些部件，则根据为您的产品指定的保修服务类型，HP 可能收取或不再收取任何附加费用。

注：某些 HP 部件的设计并未考虑客户自行维修。为了满足客户保修的需要，HP 要求授权服务提供商更换相关部件。这些部件在部件图解目录中标记为“否”。

CSR 部件将在下一个工作日发运（取决于备货情况和允许的地理范围）。在允许的地理范围内，可在当天或四小时内发运，但要收取额外费用。如果需要帮助，您可以致电 HP 技术支持中心，将会有技术人员通过电话为您提供帮助。HP 会在随更换的 CSR 部件发运的材料中指明是否必须将有缺陷的部件返还给 HP。如果要求您将有缺陷的部件返还给 HP，那么您必须在规定期限内（通常是五 (5) 个工作日）将缺陷部件发给 HP。有缺陷的部件必须随所提供的发运材料中的相关文件一起返还。如果未能送还有缺陷的部件，HP 可能会要求您支付更换费用。客户自行维修时，HP 将承担所有相关运输和部件返回费用，并指定快递商/承运商。

有关 HP 客户自行维修计划的详细信息，请与您当地的服务提供商联系。有关北美地区的计划，请访问 HP 网站 (<http://www.hp.com/go/selfrepair>)。

客戶自行維修

HP 產品設計了許多「客戶自行維修」(CSR) 的零件以減少維修時間，並且使得更換瑕疵零件時能有更大的彈性。如果在診斷期間 HP (或 HP 服務供應商或維修夥伴) 辨認出此項維修工作可以藉由使用 CSR 零件來完成，則 HP 將直接寄送該零件給您作更換。CSR 零件分為兩種類別：

- **強制的** — 客戶自行維修所使用的零件是強制性的。如果您要求 HP 更換這些零件，HP 將會向您收取此服務所需的外出費用與勞動成本。
- **選購的** — 客戶自行維修所使用的零件是選購的。這些零件也設計用於客戶自行維修之用。不過，如果您要求 HP 為您更換，則可能需要也可能不需要負擔額外的費用，端視針對此產品指定的保固服務類型而定。

備註：某些 HP 零件沒有消費者可自行維修的設計。為符合客戶保固，HP 需要授權的服務供應商更換零件。這些零件在圖示的零件目錄中，被標示為「否」。

基於材料取得及環境允許的情況下，CSR 零件將於下一個工作日以快遞寄送。在環境的允許下當天或四小時內送達，則可能需要額外的費用。若您需要協助，可致電「HP 技術支援中心」，會有一位技術人員透過電話來協助您。不論損壞的零件是否必須退回，HP 皆會在與 CSR 替換零件一起運送的材料中註明。若要將損壞的零件退回 HP，您必須在指定的一段時間內（通常為五 (5) 個工作天），將損壞的零件寄回 HP。損壞的零件必須與寄送資料中隨附的相關技術文件一併退還。如果無法退還損壞的零件，HP 可能向您收取替換費用。針對客戶自行維修情形，HP 將負責所有運費及零件退還費用並指定使用何家快遞/貨運公司。

如需 HP 的「客戶自行維修」方案詳細資訊，請連絡您當地的服務供應商。至於北美方案，請參閱 HP 網站 (<http://www.hp.com/go/selfrepair>)。

고객 셀프 수리

HP 제품은 수리 시간을 최소화하고 결함이 있는 부품 교체 시 더욱 융통성을 발휘할 수 있도록 하기 위해 고객 셀프 수리(CSR) 부품을 다량 사용하여 설계되었습니다. 진단 기간 동안 HP(또는 HP 서비스 공급업체 또는 서비스 협력업체)에서 CSR 부품을 사용하여 수리가 가능하다고 판단되면 HP는 해당 부품을 바로 사용자에게 보내어 사용자가 교체할 수 있도록 합니다. CSR 부품에는 두 가지 종류가 있습니다.

- **고객 셀프 수리가 의무 사항인 필수 부품.** 사용자가 HP에 이 부품의 교체를 요청할 경우 이 서비스에 대한 출장비 및 작업비가 청구됩니다.
- **고객 셀프 수리가 선택 사항인 부품.** 이 부품들도 고객 셀프 수리가 가능하도록 설계되었습니다. 하지만 사용자가 HP에 이 부품의 교체를 요청할 경우 사용자가 구입한 제품에 해당하는 보증 서비스 유형에 따라 추가 비용 없이 교체가 가능할 수 있습니다.

참고: 일부 HP 부품은 고객 셀프 수리가 불가능하도록 설계되었습니다. HP는 만족스러운 고객 보증을 위해 공인 서비스 제공업체를 통해 부품을 교체하도록 하고 있습니다. 이러한 부품들은 Illustrated Parts Catalog에 "No"라고 표시되어 있습니다.

CSR 부품은 재고 상태와 지리적 조건이 허용하는 경우 다음 영업일 납품이 가능하도록 배송이 이루어집니다. 지리적 조건이 허용하는 경우 추가 비용이 청구되는 조건으로 당일 또는 4시간 배송이 가능할 수도 있습니다. 도움이 필요하시면 HP 기술 지원 센터로 전화하십시오. 전문 기술자가 전화로 도움을 줄 것입니다. HP는 결함이 발생한 부품을 HP로 반환해야 하는지 여부를 CSR 교체 부품과 함께 배송된 자료에 지정합니다. 결함이 발생한 부품을 HP로 반환해야 하는 경우에는 지정된 기간 내(통상 영업일 기준 5일)에 HP로 반환해야 합니다. 이 때 결함이 발생한 부품은 제공된 포장 재료에 넣어 관련 설명서와 함께 반환해야 합니다. 결함이 발생한 부품을 반환하지 않는 경우 HP가 교체 부품에 대해 비용을 청구할 수 있습니다. 고객 셀프 수리의 경우, HP는 모든 운송 및 부품 반환 비용을 부담하며 이용할 운송업체 및 택배 서비스를 결정합니다.

HP 고객 셀프 수리 프로그램에 대한 자세한 내용은 가까운 서비스 제공업체에 문의하십시오. 북미 지역의 프로그램에 대해서는 HP 웹 사이트(<http://www.hp.com/go/selfrepair>)를 참조하십시오.

Acronyms and abbreviations

ACU

Array Configuration Utility

ADG

Advanced Data Guarding (also known as RAID 6)

ADU

Array Diagnostics Utility

CSA

Canadian Standards Association

HBA

host bus adapter

IEC

International Electrotechnical Commission

IEEE

Institute of Electrical and Electronics Engineers

IML

Integrated Management Log

MSA

Modular Smart Array

MSA60

Modular Storage Array 60

NEC

National Electrical Code

NEMA

National Electrical Manufacturers Association

NFPA

National Fire Protection Association

ORCA

Option ROM Configuration for Arrays

OSEM

Open Services Event Manager

PSP

ProLiant Support Pack

RAID

redundant array of inexpensive (or independent) disks

RBSU

ROM-Based Setup Utility

SAS

serial attached SCSI

SATA

serial ATA

SCSI

small computer system interface

SFF

small form-factor

SIM

Systems Insight Manager

TMRA

recommended ambient operating temperature

UID

unit identification

Index

A

ADU (Array Diagnostic Utility) 27
airflow requirements 13
Array Diagnostic Utility (ADU) 27
authorized reseller 41

B

BSMI notice 37
buttons 6

C

cables 36
Care Pack 27
Change Control 27
component identification 6, 7
components 6, 7
compromised fault tolerance 30
configuration 20
configuration of system 25
configuration tools 25
connectors 6
contacting HP 41
CSR (customer self repair) 41
customer self repair (CSR) 41

D

Declaration of Conformity 35
diagnostic tools 26
drive failure, detecting 32

E

electrical grounding requirements 15
electrostatic discharge 39
environmental requirements 13

F

failure, hard drive 32
fault tolerance, compromised 30

Federal Communications Commission (FCC)
notice 34, 35, 36
front panel LEDs 6

G

grounding methods 39
grounding requirements 15
guidelines, cabling 21

H

hard drive blanks 23
hard drive LEDs 9
hard drive, failure of 29
hard drives 9, 23
hardware options 19, 23
hardware options installation 23
HP ProLiant Essentials Foundation Pack 26
HP Systems Insight Manager, overview 26
HP technical support 41

I

IML (Integrated Management Log) 26
installation, server options 23
Integrated Management Log (IML) 26

J

Japanese notice 37

K

kit contents 15
Korean notices 38

L

LEDs 6, 9
LEDs, troubleshooting 9, 28

M

Management Agents 26
management tools 26

O

Open Services Event Manager 27
optimum environment 13
Option ROM Configuration for Arrays (ORCA) 25
options installation 23
ORCA (Option ROM Configuration for Arrays) 25

P

phone numbers 41
power cord 22, 38
power requirements 14
powering up 11
problem diagnosis 28

R

rack installation 15
rack mounting hardware 15
rack resources 13
rack warnings 15
rear panel buttons 8
rear panel components 7
rear panel LEDs 8
regulatory compliance notices 34, 36
remote support and analysis tools 27
required information 41
requirements, airflow 13
requirements, power 14
requirements, space 13
requirements, temperature 14

S

safety considerations 15
SAS drive numbers 9
series number 34
server features and options 23
shipping carton contents 15
site requirements 13
Smart Components for Remote ROM Flash 26
software 25
space requirements 13
specifications 40
specifications, storage enclosure 40
static electricity 39
support 27, 41
Systems Insight Manager 26

T

technical support 41

telephone numbers 41
temperature requirements 14
troubleshooting 9, 28

U

utilities 25

W

warnings 15