



IBM System x3550 M3
Type 4254 and 7944

Problem Determination and Service Guide





IBM System x3550 M3
Type 4254 and 7944

Problem Determination and Service Guide

Note

Before using this information and the product it supports, read the general information in “Getting help and technical assistance,” on page 483, “Notices” on page 487, the *Warranty Information* document, and the *Safety Information* and *Environmental Notices and User Guide* documents on the IBM Documentation CD.

Thirteenth Edition (June 2014)

© Copyright IBM Corporation 2013.

US Government Users Restricted Rights – Use, duplication or disclosure restricted by GSA ADP Schedule Contract with IBM Corp.

Contents

Safety	vii
Guidelines for trained service technicians	ix
Inspecting for unsafe conditions	ix
Guidelines for servicing electrical equipment	x
Safety statements	xi

Chapter 1. Start here	1
Diagnosing a problem	1
Undocumented problems	3

Chapter 2. The IBM System x3550 M3 server	5
Related documentation	5
Notices and statements in this document	6
Features and specifications.	7
Server controls, LEDs, and power	10
Front view.	10
Operator information panel	11
Light path diagnostics panel.	12
Rear view	14
Server power features	16
Turning on the server	16
Turning off the server	17
Internal LEDs, connectors, and jumpers	18
System-board internal connectors	18
System-board external connectors	19
System-board switches and jumpers	19
System-board LEDs.	22
System-board optional device connectors	23

Chapter 3. Diagnostics	25
Diagnostic tools	26
Event logs	27
Viewing event logs from the Setup utility	28
Viewing event logs without restarting the server	28
Clearing the error logs.	29
Error messages	30
System event log	30
Integrated management module (IMM) error messages	30
POST	242
POST error codes	242
Diagnostic programs and messages	255
Running the diagnostic programs	255
Diagnostic text messages	256
Viewing the test log	257
Diagnostic messages	257
Checkout procedure	290
About the checkout procedure.	290
Performing the checkout procedure	291
Troubleshooting tables	292
DVD drive problems	292
General problems	293
Hard disk drive problems	294
Hypervisor problems	295

Intermittent problems	296
Keyboard, mouse, or pointing-device problems	297
Memory problems.	298
Microprocessor problems	300
Monitor and video problems	300
Optional-device problems	303
Power problems	304
Serial-device problems	307
ServerGuide problems	307
Software problems.	308
Universal Serial Bus (USB) port problems	309
Video problems.	309
Light path diagnostics	309
Light path diagnostics LEDs	312
Power-supply LEDs	319
AC power-supply LEDs	319
DC power-supply LEDs	321
System pulse LEDs	322
Recovering the server firmware	323
In-band manual recovery method	324
In-band automated boot recovery method	326
Out-of-band method	327
Automated boot recovery (ABR)	327
Nx boot failure	327
Solving power problems.	328
Solving Ethernet controller problems	328
Solving undetermined problems	329
Problem determination tips.	330

Chapter 4. Parts listing, IBM System x3550 M3 Type 4254 and 7944	333
Replaceable server components	333
Consumable parts	339
Product recovery CDs	339
Power cords	344

Chapter 5. Removing and replacing components	347
Installation guidelines	347
System reliability guidelines	349
Working inside the server with the power on	349
Handling static-sensitive devices	350
Returning a device or component	350
Internal cable routing and connectors	350
Removing and replacing consumable parts and Tier 1 CRUs	355
Removing the cover	356
Installing the cover	357
Removing the microprocessor 2 air baffle	358
Installing the microprocessor 2 air baffle	359
Removing the DIMM air baffle	360
Installing the DIMM air baffle	361
Removing a memory module	362
Installing a memory module	363
DIMM installation sequence	366

Memory mirroring	366
Online-spare memory	368
Installing a DIMM.	369
Removing a hot-swap hard disk drive	370
Installing a hot-swap hard disk drive	371
IDs for hot-swap hard disk drives	372
Removing a simple-swap hard disk drive	372
Installing a simple-swap hard disk drive	373
IDs for simple-swap hard disk drives	375
Removing an optional DVD drive	375
Installing an optional DVD drive.	377
Removing an adapter.	381
Replacing an adapter.	382
Removing the SAS/SATA RAID riser-card assembly	385
Installing the SAS/SATA RAID riser-card assembly	386
Removing a ServeRAID SAS/SATA controller from the SAS/SATA RAID riser card	387
Installing a ServeRAID SAS/SATA controller on the SAS/SATA RAID riser card	389
Removing an optional ServeRAID adapter advanced feature key.	392
Installing an optional ServeRAID adapter advanced feature key.	394
Removing a hot-swap fan assembly	396
Installing a hot-swap fan assembly	398
Removing a hot-swap ac power supply	399
Installing a hot-swap ac power supply	401
Removing a USB embedded hypervisor flash device	404
Installing a USB embedded hypervisor flash device	405
Removing the virtual media key	406
Installing the virtual media key	407
Removing the optional two-port Ethernet adapter	408
Installing the optional two-port Ethernet adapter	409
Removing a remotely installed RAID adapter battery	412
Installing a RAID adapter battery remotely in the server	413
Removing the system battery	415
Installing the system battery	417
Removing and replacing Tier 2 CRUs	418
Removing the bezel	418
Installing the bezel	419
Removing an optional optical drive cage	420
Installing an optional optical drive cage	421
Removing the DVD cable	422
Installing the DVD cable	423
Removing a PCI riser-card assembly.	425
Installing a PCI riser-card assembly	426
Removing the PCI riser-card bracket from the riser card	427
Installing the PCI riser-card bracket to the riser card	428
Removing the hot-swap SAS/SATA hard disk drive backplane	429

Installing the hot-swap SAS/SATA hard disk drive backplane	430
Removing the simple-swap SATA hard disk drive backplate assembly	431
Installing the simple-swap SATA hard disk drive backplate assembly	432
Removing the operator information panel assembly	433
Installing the operator information panel assembly	434
Removing and replacing FRUs	436
Removing the 240 VA safety cover	437
Installing the 240 VA safety cover	438
Removing a microprocessor and heat sink	439
Installing a microprocessor and heat sink	441
Thermal grease	446
Removing a heat sink retention module	447
Installing a heat sink retention module	448
Removing the system board	449
Installing the system board	451

Chapter 6. Configuration information and instructions 455

Updating the firmware	455
Configuring the server	456
Using the ServerGuide Setup and Installation CD.	458
ServerGuide features	458
Setup and configuration overview	459
Typical operating-system installation	459
Installing your operating system without using ServerGuide.	460
Using the Setup utility	460
Starting the Setup utility	460
Setup utility menu choices	461
Passwords	464
Using the Boot Manager program	466
Starting the backup server firmware.	466
Using the integrated management module.	467
Using the remote presence capability and blue-screen capture	468
Enabling the remote presence feature	469
Obtaining the IP address for the IMM	469
Logging on to the Web interface	470
Using the embedded hypervisor	470
Recovering the flash device image	471
Enabling the Broadcom Gigabit Ethernet Utility program	471
Configuring the Gigabit Ethernet controller	472
Using the LSI Configuration Utility program	472
Starting the LSI Configuration Utility program	473
Formatting a hard disk drive	474
Creating a RAID array of hard disk drives	474
IBM Advanced Settings Utility program	475
Updating IBM Systems Director	475
Installing a newer version	475
Installing updates with your management server is connected to the Internet	476
Installing updates with your management server is not connected to the Internet	476

Updating the Universal Unique Identifier (UUID)	477
Updating the DMI/SMBIOS data	479

Appendix. Getting help and technical assistance. 483

Before you call	483
Using the documentation	484
Getting help and information from the World Wide Web	484
How to send DSA data to IBM	484
Creating a personalized support web page	485
Software service and support	485
Hardware service and support	485
IBM Taiwan product service	485

Notices 487

Trademarks	488
Important notes	488
Particulate contamination	489
Documentation format	490
Telecommunication regulatory statement	490
Electronic emission notices	491

Federal Communications Commission (FCC) statement	491
Industry Canada Class A emission compliance statement	491
Avis de conformité à la réglementation d'Industrie Canada	491
Australia and New Zealand Class A statement	491
European Union EMC Directive conformance statement	492
Germany Class A statement	492
Japan VCCI Class A statement	493
Japan Electronics and Information Technology Industries Association (JEITA) statement	494
Korea Communications Commission (KCC) statement	494
Russia Electromagnetic Interference (EMI) Class A statement	494
People's Republic of China Class A electronic emission statement	494
Taiwan Class A compliance statement	495

Index 497

Safety

Before installing this product, read the Safety Information.

قبل تركيب هذا المنتج، يجب قراءة الملاحظات الأمنية

Antes de instalar este produto, leia as Informações de Segurança.

在安装本产品之前，请仔细阅读 **Safety Information**
(安全信息)。

安裝本產品之前，請先閱讀「安全資訊」。

Prije instalacije ovog produkta obavezno pročitajte Sigurnosne Upute.

Před instalací tohoto produktu si přečtěte příručku bezpečnostních instrukcí.

Læs sikkerhedsforskrifterne, før du installerer dette produkt.

Lees voordat u dit product installeert eerst de veiligheidsvoorschriften.

Ennen kuin asennat tämän tuotteen, lue turvaohjeet kohdasta Safety Information.

Avant d'installer ce produit, lisez les consignes de sécurité.

Vor der Installation dieses Produkts die Sicherheitshinweise lesen.

Πριν εγκαταστήσετε το προϊόν αυτό, διαβάστε τις πληροφορίες ασφάλειας
(safety information).

לפני שתתקינו מוצר זה, קראו את הוראות הבטיחות.

A termék telepítése előtt olvassa el a Biztonsági előírásokat!

Prima di installare questo prodotto, leggere le Informazioni sulla Sicurezza.

製品の設置の前に、安全情報をお読みください。

본 제품을 설치하기 전에 안전 정보를 읽으십시오.

Пред да се инсталира овој продукт, прочитајте информацијата за безбедност.

بھارتی
پاکستان
ہندوستان
بنگلہ دیش
میانمار
ویتنام
لاؤس
کمبوڈیا
مالڈیو

Les sikkerhetsinformasjonen (Safety Information) før du installerer dette produktet.

Przed zainstalowaniem tego produktu, należy zapoznać się z książką "Informacje dotyczące bezpieczeństwa" (Safety Information).

Antes de instalar este produto, leia as Informações sobre Segurança.

Перед установкой продукта прочтите инструкции по технике безопасности.

Pred inštaláciou tohto zariadenia si pečítajte Bezpečnostné predpisy.

Pred namestitvijo tega proizvoda preberite Varnostne informacije.

Antes de instalar este producto, lea la información de seguridad.

Läs säkerhetsinformationen innan du installerar den här produkten.

ཐོན་རྒྱུ་འདི་བདེ་སྲོད་མ་བྱས་གོང་། རྒྱུ་ལྡན་གྱི་ཡིད་གཟབ་
བྱ་འདྲ་མིན་ཡོད་པའི་འོད་སྟེང་བལྟ་དགོས།

Bu ürünü kurmadan önce güvenlik bilgilerini okuyun.

مەزكۇر مەھسۇلاتنى ئورنىتىشتىن بۇرۇن بىخەتەرلىك ئۇچۇرلىرىنى ئوقۇپ چىقىڭ.

Youq mwngz yungh canjbinj neix gaxgonq, itdingh aeu doeg aen canjbinj soengq cungj vahgangj ancien siusik.

Guidelines for trained service technicians

This section contains information for trained service technicians.

Inspecting for unsafe conditions

Use this information to help you identify potential unsafe conditions in an IBM® product that you are working on.

Each IBM product, as it was designed and manufactured, has required safety items to protect users and service technicians from injury. The information in this section addresses only those items. Use good judgment to identify potential unsafe conditions that might be caused by non-IBM alterations or attachment of non-IBM features or optional devices that are not addressed in this section. If you identify an unsafe condition, you must determine how serious the hazard is and whether you must correct the problem before you work on the product.

Consider the following conditions and the safety hazards that they present:

- Electrical hazards, especially primary power. Primary voltage on the frame can cause serious or fatal electrical shock.
- Explosive hazards, such as a damaged CRT face or a bulging capacitor.
- Mechanical hazards, such as loose or missing hardware.

To inspect the product for potential unsafe conditions, complete the following steps:

1. Make sure that the power is off and the power cords are disconnected.
2. Make sure that the exterior cover is not damaged, loose, or broken, and observe any sharp edges.
3. Check the power cords:
 - Make sure that the third-wire ground connector is in good condition. Use a meter to measure third-wire ground continuity for 0.1 ohm or less between the external ground pin and the frame ground.
 - Make sure that the power cords are the correct type.
 - Make sure that the insulation is not frayed or worn.
4. Remove the cover.
5. Check for any obvious non-IBM alterations. Use good judgment as to the safety of any non-IBM alterations.
6. Check inside the system for any obvious unsafe conditions, such as metal filings, contamination, water or other liquid, or signs of fire or smoke damage.
7. Check for worn, frayed, or pinched cables.
8. Make sure that the power-supply cover fasteners (screws or rivets) have not been removed or tampered with.

Guidelines for servicing electrical equipment

Observe these guidelines when you service electrical equipment.

- Check the area for electrical hazards such as moist floors, nongrounded power extension cords, and missing safety grounds.
- Use only approved tools and test equipment. Some hand tools have handles that are covered with a soft material that does not provide insulation from live electrical current.
- Regularly inspect and maintain your electrical hand tools for safe operational condition. Do not use worn or broken tools or testers.
- Do not touch the reflective surface of a dental mirror to a live electrical circuit. The surface is conductive and can cause personal injury or equipment damage if it touches a live electrical circuit.
- Some rubber floor mats contain small conductive fibers to decrease electrostatic discharge. Do not use this type of mat to protect yourself from electrical shock.
- Do not work alone under hazardous conditions or near equipment that has hazardous voltages.
- Locate the emergency power-off (EPO) switch, disconnecting switch, or electrical outlet so that you can turn off the power quickly in the event of an electrical accident.
- Disconnect all power before you perform a mechanical inspection, work near power supplies, or remove or install main units.
- Before you work on the equipment, disconnect the power cord. If you cannot disconnect the power cord, have the customer power-off the wall box that supplies power to the equipment and lock the wall box in the off position.
- Never assume that power has been disconnected from a circuit. Check it to make sure that it has been disconnected.
- If you have to work on equipment that has exposed electrical circuits, observe the following precautions:
 - Make sure that another person who is familiar with the power-off controls is near you and is available to turn off the power if necessary.
 - When you work with powered-on electrical equipment, use only one hand. Keep the other hand in your pocket or behind your back to avoid creating a complete circuit that could cause an electrical shock.
 - When you use a tester, set the controls correctly and use the approved probe leads and accessories for that tester.
 - Stand on a suitable rubber mat to insulate you from grounds such as metal floor strips and equipment frames.
- Use extreme care when you measure high voltages.
- To ensure proper grounding of components such as power supplies, pumps, blowers, fans, and motor generators, do not service these components outside of their normal operating locations.
- If an electrical accident occurs, use caution, turn off the power, and send another person to get medical aid.

Safety statements

These statements provide the caution and danger information that is used in this documentation.

Important:

Each caution and danger statement in this documentation is labeled with a number. This number is used to cross reference an English-language caution or danger statement with translated versions of the caution or danger statement in the *Safety Information* document.

For example, if a caution statement is labeled Statement 1, translations for that caution statement are in the *Safety Information* document under Statement 1.

Be sure to read all caution and danger statements in this documentation before you perform the procedures. Read any additional safety information that comes with your system or optional device before you install the device.

Statement 1



DANGER

Electrical current from power, telephone, and communication cables is hazardous.

To avoid a shock hazard:

- **Do not connect or disconnect any cables or perform installation, maintenance, or reconfiguration of this product during an electrical storm.**
- **Connect all power cords to a properly wired and grounded electrical outlet.**
- **Connect to properly wired outlets any equipment that will be attached to this product.**
- **When possible, use one hand only to connect or disconnect signal cables.**
- **Never turn on any equipment when there is evidence of fire, water, or structural damage.**
- **Disconnect the attached power cords, telecommunications systems, networks, and modems before you open the device covers, unless instructed otherwise in the installation and configuration procedures.**
- **Connect and disconnect cables as described in the following table when installing, moving, or opening covers on this product or attached devices.**

To Connect:

1. Turn everything OFF.
2. First, attach all cables to devices.
3. Attach signal cables to connectors.
4. Attach power cords to outlet.
5. Turn device ON.

To Disconnect:

1. Turn everything OFF.
2. First, remove power cords from outlet.
3. Remove signal cables from connectors.
4. Remove all cables from devices.

Statement 2



CAUTION:

When replacing the lithium battery, use only IBM Part Number 33F8354 or an equivalent type battery recommended by the manufacturer. If your system has a module containing a lithium battery, replace it only with the same module type made by the same manufacturer. The battery contains lithium and can explode if not properly used, handled, or disposed of.

Do not:

- Throw or immerse into water
- Heat to more than 100°C (212°F)
- Repair or disassemble

Dispose of the battery as required by local ordinances or regulations.

Statement 3



CAUTION:

When laser products (such as CD-ROMs, DVD drives, fiber optic devices, or transmitters) are installed, note the following:

- Do not remove the covers. Removing the covers of the laser product could result in exposure to hazardous laser radiation. There are no serviceable parts inside the device.
- Use of controls or adjustments or performance of procedures other than those specified herein might result in hazardous radiation exposure.



DANGER

Some laser products contain an embedded Class 3A or Class 3B laser diode. Note the following.

Laser radiation when open. Do not stare into the beam, do not view directly with optical instruments, and avoid direct exposure to the beam.

Class 1 Laser Product
Laser Klasse 1
Laser Klass 1
Luokan 1 Laserlaite
Appareil À Laser de Classe 1

Statement 4



CAUTION:
Use safe practices when lifting.

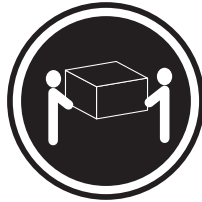

≥ 18 kg (39.7 lb)



≥ 32 kg (70.5 lb)



≥ 55 kg (121.2 lb)

Statement 5



CAUTION:
The power control button on the device and the power switch on the power supply do not turn off the electrical current supplied to the device. The device also might have more than one power cord. To remove all electrical current from the device, ensure that all power cords are disconnected from the power source.

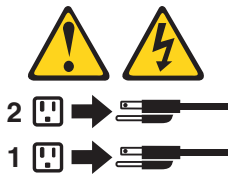

Statement 6



CAUTION:

If you install a strain-relief bracket option over the end of the power cord that is connected to the device, you must connect the other end of the power cord to an easily accessible power source.

Statement 8



CAUTION:

Never remove the cover on a power supply or any part that has the following label attached.



Hazardous voltage, current, and energy levels are present inside any component that has this label attached. There are no serviceable parts inside these components. If you suspect a problem with one of these parts, contact a service technician.

Statement 12



CAUTION:

The following label indicates a hot surface nearby.



Statement 26



CAUTION:

Do not place any object on top of rack-mounted devices.



Rack Safety Information, Statement 2



DANGER

- Always lower the leveling pads on the rack cabinet.
- Always install stabilizer brackets on the rack cabinet.
- Always install servers and optional devices starting from the bottom of the rack cabinet.
- Always install the heaviest devices in the bottom of the rack cabinet.

Chapter 1. Start here

You can solve many problems without outside assistance by following the troubleshooting procedures in this documentation and on the World Wide Web.

This document describes the diagnostic tests that you can perform, troubleshooting procedures, and explanations of error messages and error codes. The documentation that comes with your operating system and software also contains troubleshooting information.

Diagnosing a problem

Before you contact IBM or an approved warranty service provider, follow these procedures in the order in which they are presented to diagnose a problem with your server.

Procedure

1. **Return the server to the condition it was in before the problem occurred.** If any hardware, software, or firmware was changed before the problem occurred, if possible, reverse those changes. This might include any of the following items:
 - Hardware components
 - Device drivers and firmware
 - System software
 - UEFI firmware
 - System input power or network connections
2. **View the light path diagnostics LEDs and event logs.** The server is designed for ease of diagnosis of hardware and software problems.
 - **Light path diagnostics LEDs:** See “Light path diagnostics” on page 309 for information about using light path diagnostics LEDs.
 - **Event logs:** See “Event logs” on page 27 for information about notification events and diagnosis.
 - **Software or operating-system error codes:** See the documentation for the software or operating system for information about a specific error code. See the manufacturer's website for documentation.
3. **Run IBM Dynamic System Analysis (DSA) and collect system data.** Run Dynamic System Analysis (DSA) to collect information about the hardware, firmware, software, and operating system. Have this information available when you contact IBM or an approved warranty service provider. For instructions for running DSA, see the *Dynamic System Analysis Installation and User's Guide*.

To download the latest version of DSA code and the *Dynamic System Analysis Installation and User's Guide*, go to <http://www.ibm.com/support/entry/portal/docdisplay?lnocid=SERV-DSA>.
4. **Check for and apply code updates.** Fixes or workarounds for many problems might be available in updated UEFI firmware, device firmware, or device drivers. To display a list of available updates for the server, go to <http://www.ibm.com/support/fixcentral/>.

Attention: Installing the wrong firmware or device-driver update might cause the server to malfunction. Before you install a firmware or device-driver update, read any readme and change history files that are provided with the downloaded update. These files contain important information about the update and the procedure for installing the update, including any special procedure for updating from an early firmware or device-driver version to the latest version.

Important: Some cluster solutions require specific code levels or coordinated code updates. If the device is part of a cluster solution, verify that the latest level of code is supported for the cluster solution before you update the code.

a. **Install UpdateXpress system updates.** You can install code updates that are packaged as an UpdateXpress System Pack or UpdateXpress CD image. An UpdateXpress System Pack contains an integration-tested bundle of online firmware and device-driver updates for your server. In addition, you can use IBM ToolsCenter Bootable Media Creator to create bootable media that is suitable for applying firmware updates and running preboot diagnostics. For more information about UpdateXpress System Packs, see <http://www.ibm.com/support/entry/portal/docdisplay?Indocid=SERV-XPRESS> and “Updating the firmware” on page 455. For more information about the Bootable Media Creator, see <http://www.ibm.com/support/entry/portal/docdisplay?Indocid=TOOL-BOMC>.

Be sure to separately install any listed critical updates that have release dates that are later than the release date of the UpdateXpress System Pack or UpdateXpress image (see step 4b).

b. **Install manual system updates.**

1) **Determine the existing code levels.**

In DSA, click **Firmware/VPD** to view system firmware levels, or click **Software** to view operating-system levels.

2) **Download and install updates of code that is not at the latest level.**

To display a list of available updates for the server, go to <http://www.ibm.com/support/fixcentral/>.

When you click an update, an information page is displayed, including a list of the problems that the update fixes. Review this list for your specific problem; however, even if your problem is not listed, installing the update might solve the problem.

5. **Check for and correct an incorrect configuration.** If the server is incorrectly configured, a system function can fail to work when you enable it; if you make an incorrect change to the server configuration, a system function that has been enabled can stop working.

a. **Make sure that all installed hardware and software are supported.** See <http://www.ibm.com/systems/info/x86servers/serverproven/compat/us/> to verify that the server supports the installed operating system, optional devices, and software levels. If any hardware or software component is not supported, uninstall it to determine whether it is causing the problem. You must remove nonsupported hardware before you contact IBM or an approved warranty service provider for support.

b. **Make sure that the server, operating system, and software are installed and configured correctly.** Many configuration problems are caused by loose power or signal cables or incorrectly seated adapters. You might be able to solve the problem by turning off the server, reconnecting cables, reseating adapters, and turning the server back on. For information about performing the checkout procedure, see “About the checkout procedure” on page 290.

For information about configuring the server, see Chapter 6, “Configuration information and instructions,” on page 455.

6. **See controller and management software documentation.** If the problem is associated with a specific function (for example, if a RAID hard disk drive is marked offline in the RAID array), see the documentation for the associated controller and management or controlling software to verify that the controller is correctly configured.

Problem determination information is available for many devices such as RAID and network adapters.

For problems with operating systems or IBM software or devices, go to <http://www.ibm.com/supportportal/>.

7. **Check for troubleshooting procedures and RETAIN tips.** Troubleshooting procedures and RETAIN tips document known problems and suggested solutions. To search for troubleshooting procedures and RETAIN tips, go to <http://www.ibm.com/supportportal/>.

8. **Use the troubleshooting tables.** See “Troubleshooting tables” on page 292 to find a solution to a problem that has identifiable symptoms.

A single problem might cause multiple symptoms. Follow the troubleshooting procedure for the most obvious symptom. If that procedure does not diagnose the problem, use the procedure for another symptom, if possible.

If the problem remains, contact IBM or an approved warranty service provider for assistance with additional problem determination and possible hardware replacement. To open an online service request, go to http://www.ibm.com/support/entry/portal/Open_service_request/. Be prepared to provide information about any error codes and collected data.

Undocumented problems

If you have completed the diagnostic procedure and the problem remains, the problem might not have been previously identified by IBM. After you have verified that all code is at the latest level, all hardware and software configurations are valid, and no light path diagnostics LEDs or log entries indicate a hardware component failure, contact IBM or an approved warranty service provider for assistance.

To open an online service request, go to http://www.ibm.com/support/entry/portal/Open_service_request/. Be prepared to provide information about any error codes and collected data and the problem determination procedures that you have used.

Chapter 2. The IBM System x3550 M3 server

This publication contains information and instructions for setting up your IBM System x3550 M3 server, instructions for installing some optional devices, cabling and configuring the server, removing and replacing devices, and diagnostics and troubleshooting information.

The most recent version of this document is available at <http://www.ibm.com/supportportal/>.

For information about the terms of the warranty, see the *Warranty Information* document that comes with the server. For information about getting service and assistance, see “Getting help and technical assistance,” on page 483.

Related documentation

This publication contains general information about the server including how to set up and cable the server, how to install supported optional devices, how to configure the server, and information to help you solve problems yourself and information for service technicians. The following documentation also comes with the server:

- *Environmental Notices and User Guide*

This document is in PDF format on the IBM *Documentation* CD. It contains translated environmental notices.

- *IBM License Agreement for Machine Code*

This document is in PDF format on the IBM *Documentation* CD. It provides translated versions of the *IBM License Agreement for Machine Code* for your product.

- *Important Notices*

This document is in printed format and comes with the server. It contains information about the safety, environmental, and electronic emission notices for your IBM product.

- *Licenses and Attributions Documents*

This document is in PDF format on the IBM *Documentation* CD. It provides the open source notices.

- *Rack Installation Instructions*

This printed document contains instructions for installing the server in a rack and comes with the rack kit.

- *Rack Safety Information*

This multilingual document provides translated versions of the caution and danger statements that appear in the rack documentation. Each caution and danger statement has an assigned number, which you can use to locate the corresponding statement in your native language.

- *Safety Information*

This document is in PDF format on the IBM *Documentation* CD. It contains translated caution and danger statements. Each caution and danger statement that appears in the documentation has a number that you can use to locate the corresponding statement in your language in the *Safety Information* document.

- *Safety Information Labels*

This document provides the Simplified Chinese, Mongolian, Tibetan, Uyghur, and Zhuang translated versions of the product safety labels.

- *Warranty Information*

This document is in printed format and comes with the server. It contains warranty terms and a pointer to the IBM Statement of Limited Warranty on the IBM website.

Depending on the server model, additional documentation might be included on the IBM *Documentation CD*.

The ToolsCenter for System x and BladeCenter is an online information center that contains information about tools for updating, managing, and deploying firmware, device drivers, and operating systems. The ToolsCenter for System x and BladeCenter is at <http://publib.boulder.ibm.com/infocenter/toolctr/v1r0/>.

The server might have features that are not described in the documentation that you received with the server. The documentation might be updated occasionally to include information about those features, or technical updates might be available to provide additional information that is not included in the server documentation. These updates are available from the IBM website. To check for updates, go to <http://www.ibm.com/supportportal/>.

Notices and statements in this document

The caution and danger statements in this document are also in the multilingual *Safety Information* document, which is on the IBM *System x Documentation CD*. Each statement is numbered for reference to the corresponding statement in your language in the *Safety Information* document.

The following notices and statements are used in this document:

- **Note:** These notices provide important tips, guidance, or advice.
- **Important:** These notices provide information or advice that might help you avoid inconvenient or problem situations.
- **Attention:** These notices indicate potential damage to programs, devices, or data. An attention notice is placed just before the instruction or situation in which damage might occur.
- **Caution:** These statements indicate situations that can be potentially hazardous to you. A caution statement is placed just before the description of a potentially hazardous procedure step or situation.
- **Danger:** These statements indicate situations that can be potentially lethal or extremely hazardous to you. A danger statement is placed just before the description of a potentially lethal or extremely hazardous procedure step or situation.

Features and specifications

The following information is a summary of the features and specifications of the server.

Depending on the server model, some features might not be available, or some specifications might not apply.

Table 1. Features and specifications

<p>Microprocessor:</p> <ul style="list-style-type: none"> • Supports up to two Intel Xeon™ multi-core microprocessors (one installed) • Level-3 cache • QuickPath Interconnect (QPI) links speed up to 6.4 GT per second <p>Notes:</p> <ul style="list-style-type: none"> • Do not install an Intel Xeon™ 5500 series microprocessor and an Xeon™ 5600 series microprocessor in the same server. • Use the Setup utility program to determine the type and speed of the microprocessors. • For a list of supported microprocessors, see http://www.ibm.com/systems/info/x86servers/serverproven/compat/us/. <p>Memory:</p> <ul style="list-style-type: none"> • Minimum: 2 GB • Maximum: 288 GB <ul style="list-style-type: none"> – 48 GB using unbuffered DIMMs (UDIMMs) – 288 GB using registered DIMMs (RDIMMs) • Type: PC3-10600R-999, 800, 1066, and 1333 MHz, ECC, DDR3 registered or unbuffered SDRAM DIMMs • Slots: 18 dual inline • Supports (depending on the model): <ul style="list-style-type: none"> – 2 GB and 4 GB unbuffered DIMMs – 2 GB, 4 GB, 8 GB, and 16 GB registered DIMMs <p>SATA optical drives (optional):</p> <ul style="list-style-type: none"> • DVD-ROM • Multi-burner <p>Hot-swap fans:</p> <p>The server comes standard with five dual-motor hot-swap fans.</p>	<p>Hard disk drive expansion bays (depending on the model):</p> <ul style="list-style-type: none"> • Up to eight 2.5-inch hot-swap SAS or hot-swap SATA hard disk drive bays • Up to four 2.5-inch hot-swap SAS/SATA or simple-swap SATA hard disk drive bays (on server models with an optional optical drive bay) <p>PCI expansion slots:</p> <p>Supports two PCI riser slots:</p> <ul style="list-style-type: none"> • Slot 1 supports low-profile cards (PCI Express Gen2 x16 or PCI-X 1.0a 64-bit/133 MHz). • Slot 2 supports half-length, full-height cards (PCI Express Gen2 x16 or PCI-X 1.0a 64-bit/133 MHz). <p>Video controller (integrated into IMM):</p> <ul style="list-style-type: none"> • Matrox G200eV (two analog ports - one front and one rear that can be connected at the same time) <p>Notes: The maximum video resolution is 1600 x 1200 at 75 Hz.</p> <ul style="list-style-type: none"> – SVGA compatible video controller – DDR2 250 MHz SDRAM video memory controller – Avocent Digital Video Compression – 16 MB of video memory (not expandable) 	<p>Power supply:</p> <ul style="list-style-type: none"> • Maximum of two hot-swap power supplies for redundancy support <ul style="list-style-type: none"> – 460-watt ac – 675-watt ac – 675-watt high-efficiency ac – 675-watt dc <p>Note: You cannot mix 460-watt and 675-watt power supplies, high-efficiency and non-high-efficiency power supplies, or ac and dc power supplies in the server.</p> <p>Environment:</p> <ul style="list-style-type: none"> • Air temperature: <ul style="list-style-type: none"> – Server on: 10°C to 35°C (50°F to 95°F); altitude: 0 to 914.4 m (3000 ft), decrease system temperature by 1.0°C for every 1000-foot increase in altitude – Server off: 5°C to 45°C (41°F to 113°F); maximum altitude: 3048 m (10000 ft) – Shipment: -40°C to 60°C (-40°F to 140°F); maximum altitude: 3048 m (10000 ft) • Humidity: <ul style="list-style-type: none"> – Server on: 20% to 80%; maximum dew point: 21°C; maximum rate of change: 5 °C/hr – Server off: 8% to 80%; maximum dew point: 27°C • Particulate contamination: <p>Attention: Airborne particulates and reactive gases acting alone or in combination with other environmental factors such as humidity or temperature might pose a risk to the server. For information about the limits for particulates and gases, see “Particulate contamination” on page 489.</p> <p>Heat output:</p> <p>Approximate heat output:</p> <ul style="list-style-type: none"> • Minimum configuration: 662 Btu per hour (194 watts) • Maximum configuration: 2302 Btu per hour (675 watts)
--	--	--

Table 1. Features and specifications (continued)

<p>Integrated functions:</p> <ul style="list-style-type: none"> • Integrated Management Module (IMM), which provides service processor control and monitoring functions, video controller, and (when the optional virtual media key is installed) remote keyboard, video, mouse, and remote hard disk drive capabilities • Broadcom BCM5709 Gb Ethernet controller with TCP/IP Offload Engine (TOE) and Wake on LAN support • Five Universal Serial Bus (USB) 2.0 ports (two front and two rear of the chassis, and one on the SAS/SATA RAID riser card in which the optional USB flash device with embedded hypervisor software is installed) • Four Ethernet ports (two on system board and two additional ports when the optional IBM Dual-Port 1 Gb Ethernet Daughter Card is installed) • One System Management RJ-45 on the rear to connect to a systems management network. This system management connector is dedicated to the IMM functions. This connector is active with or without the optional IBM Virtual Media Key installed. • One serial port 	<p>RAID controllers (depending on the model):</p> <ul style="list-style-type: none"> • A ServeRAID-BR10i v2 SAS/SATA adapter that provides RAID levels 0, 1, and 1E (comes standard on some hot-swap models). • An optional ServeRAID-BR10i SAS/SATA adapter that provides RAID levels 0, 1, and 1E can be ordered. • An optional ServeRAID-MR10i SAS/SATA adapter that provides RAID levels 0, 1, 5, 6, 10, 50, and 60 can be ordered. • An optional ServerRAID M1015 SAS/SATA adapter that provides RAID levels 0, 1, and 10 with optional RAID 5/50 and SED (Self Encrypting Drive) upgrade. • An optional ServeRAID M5014 SAS/SATA adapter that provides RAID levels 0, 1, 5, 10 and 50 with optional RAID 6/60 and SED upgrade. • An optional ServeRAID M5015 SAS/SATA adapter that provides RAID levels 0, 1, 5, 10, and 50 with optional RAID 6/60 and SED upgrade. <p>Size:</p> <ul style="list-style-type: none"> • 1U • Height: 43 mm (1.7 inches) • Depth: 711 mm (28.0 inches) • Width: 440 mm (17.3 inches) • Weight: approximately 15.9 kg (35.1 lb) when fully configured <p>Acoustical noise emissions:</p> <ul style="list-style-type: none"> • Sound power, idling: 6.1 bels maximum • Sound power, operating: 6.1 bels maximum 	<p>Electrical input:</p> <ul style="list-style-type: none"> • Sine-wave input (47 - 63 Hz) required • Input voltage low range: <ul style="list-style-type: none"> – Minimum: 100 V ac – Maximum: 127 V ac • Input voltage high range: <ul style="list-style-type: none"> – Minimum: 200 V ac – Maximum: 240 V ac • Input kilovolt-amperes (kVA), approximately: <ul style="list-style-type: none"> – Minimum: 0.090 kVA – Maximum: 0.700 kVA <p>Notes:</p> <ol style="list-style-type: none"> 1. Power consumption and heat output vary depending on the number and type of optional features installed and the power-management optional features in use. 2. The sound levels were measured in controlled acoustical environments according to the procedures specified by the American National Standards Institute (ANSI) S12.10 and ISO 7779 and are reported in accordance with ISO 9296. Actual sound-pressure levels in a given location might exceed the average values stated because of room reflections and other nearby noise sources. The noise emission level stated in the declared (upper limit) sound-power level, in bels, for a random sample of system.
--	---	--

EU Regulation 617/2013 Technical Documentation:

International Business Machines Corporation
New Orchard Road
Armonk, New York 10504
<http://www.ibm.com/customersupport/>

For more information on the energy efficiency program, go to
<http://www.ibm.com/systems/x/hardware/energy-star/index.html>

Product Type:

Computer Server

Year first manufactured:

2010

Internal/external power supply efficiency:

PSU 1:

Table 2. Power supply efficiency (PSU 1)

IRMS A	PF	ITHD (%)	Load (%)	Input Watts	Output Watts	Efficiency %
0.41	0.811	39.8%	10%	77.25	67.50	87.38%
0.72	0.901	30.5%	20%	148.45	134.74	90.76%
1.65	0.956	21.8%	50%	361.99	336.34	92.91%
3.28	0.976	17.5%	100%	736.58	670.10	90.97%

PSU 2:

Table 3. Power supply efficiency (PSU 2)

IRMS A	PF	ITHD (%)	Load (%)	Input Watts	Output Watts	Efficiency %
0.50	0.694	19.02%	10%	79.4	68.2	85.9%
0.74	0.867	15.1%	20%	148.4	134.8	90.8%
1.63	0.968	4.85%	50%	362.1	336.1	93.0%
3.24	0.988	5.3%	100%	737.3	672.3	91.2%

Maximum power (watts):

See Power supply.

Idle state power (watts):

129

Sleep mode power (watts):

N/A for servers

Off mode power (watts):

Not available

Noise levels (the declared A-weighted sound power level of the computer):

See Acoustical noise emissions.

Test voltage and frequency:

230V / 50 Hz or 60 Hz

Total harmonic distortion of the electricity supply system:

The maximum harmonic content of the input voltage waveform will be equal or less than 2%. The qualification is compliant with EN 61000-3-2.

Information and documentation on the instrumentation set-up and circuits used for electrical testing:

ENERGY STAR Test Method for Computer Servers; ECOVA Generalized Test Protocol for Calculating the Energy Efficiency of Internal Ac-Dc and Dc-Dc Power Supplies.

Measurement methodology used to determine information in this document:

ENERGY STAR Servers Version 2.0 Program Requirements; ECOVA Generalized Test Protocol for Calculating the Energy Efficiency of Internal Ac-Dc and Dc-Dc Power Supplies.

Server controls, LEDs, and power

This section describes the controls and light-emitting diodes (LEDs) and how to turn the server on and off.

For the location of the LEDs on the system board, see “System-board LEDs” on page 22.

Front view

Use this information to view the controls, LEDs, and connectors on the front of the server.

The following illustration shows the controls, LEDs, and connectors on the front of the server.

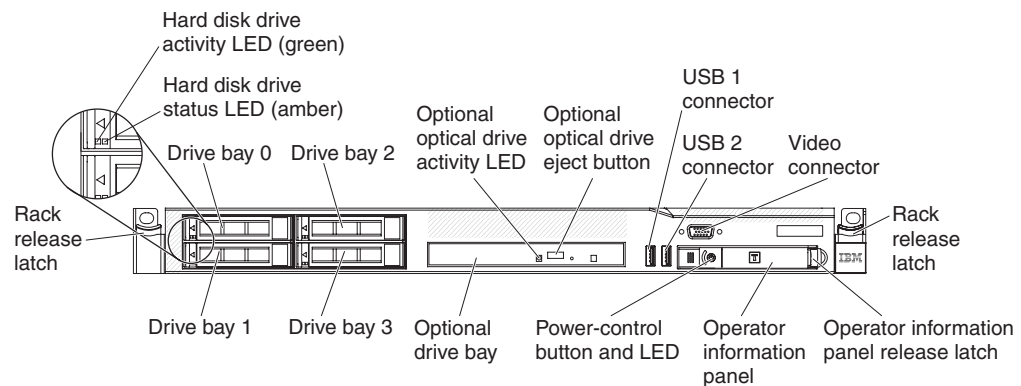

Figure 1. Front view

The following illustration shows the front of the simple-swap server model.

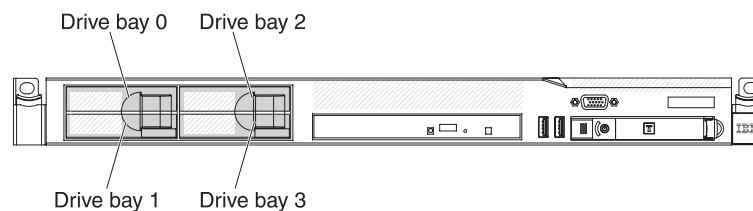

Figure 2. Front view: simple-swap HDD model

- **Rack release latches:** Press the latches on each front side of the server to remove the server from the rack.
- **Hard disk drive activity LEDs:** This LED is used on hot-swap SAS or SATA hard disk drives. Each hot-swap hard disk drive has an activity LED, and when this LED is flashing, it indicates that the drive is in use.
- **Hard disk drive status LEDs:** This LED is used on hot-swap SAS or SATA hard disk drives. When this LED is lit, it indicates that the drive has failed. If an optional IBM ServeRAID controller is installed in the server, when this LED is flashing slowly (one flash per second), it indicates that the drive is being rebuilt. When the LED is flashing rapidly (three flashes per second), it indicates that the controller is identifying the drive.
- **Optional DVD eject button:** Press this button to release a DVD or CD from the DVD drive.

- **Optional DVD drive activity LED:** When this LED is lit, it indicates that the DVD drive is in use.
- **Operator information panel:** This panel contains controls and LEDs that provide information about the status of the server.
- **Operator information panel release latch:** Slide the blue release latch to the left to pull out the light path diagnostics panel and view the light path diagnostics LEDs and buttons. See “Light path diagnostics panel” on page 12 for more information about the light path diagnostics.
- **Video connector:** Connect a monitor to this connector. The video connectors on the front and rear of the server can be used simultaneously.
- **USB connectors:** Connect a USB device, such as a USB mouse or keyboard to any of these connectors.

Operator information panel

Use this information to view the operator information panel.

The following illustration shows the controls and LEDs on the operator information panel.

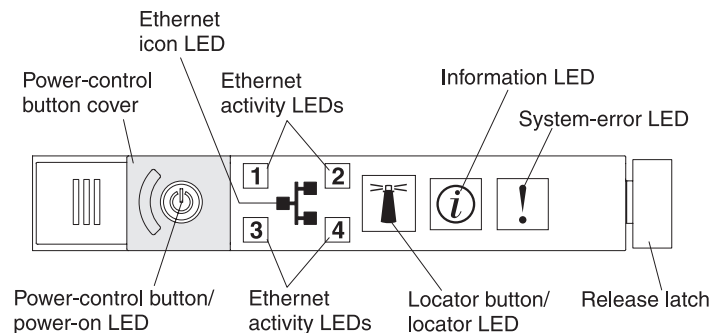

Figure 3. Operator information panel

- **Power-control button and power-on LED:** Press this button to turn the server on and off manually or to wake the server from a reduced-power state. The states of the power-on LED are as follows:
 - Off:** AC power is not present, or the power supply or the LED itself has failed.
 - Flashing rapidly (4 times per second):** The server is turned off and is not ready to be turned on. The power-control button is disabled. This will last approximately 20 to 40 seconds.
 - Flashing slowly (once per second):** The server is turned off and is ready to be turned on. You can press the power-control button to turn on the server.
 - Lit:** The server is turned on.
 - Fading on and off:** The server is in a reduced-power state. To wake the server, press the power-control button or use the IMM web interface. See “Logging on to the Web interface” on page 470 for information on logging on to the IMM web interface.
- **Ethernet activity LEDs:** When any of these LEDs is lit, they indicate that the server is transmitting to or receiving signals from the Ethernet LAN that is connected to the Ethernet port that corresponds to that LED.
- **System-locator button/LED:** Use this blue LED to visually locate the server among other servers. This LED is also used as a presence detection button. You

can use IBM Systems Director to light this LED remotely. This LED is controlled by the IMM. When you press the System-locator button, the LED will blink and it will continue to blink until you press it again to turn it off. The locator button is pressed to visually locate the server among the others servers.

- **System-information LED:** When this amber LED is lit, it indicates that a noncritical event has occurred. Check the error log for additional information.
- **System-error LED:** When this amber LED is lit, it indicates that a system error has occurred. A system-error LED is also on the rear of the server. An LED on the light path diagnostics panel on the operator information panel is also lit to help isolate the error. This LED is controlled by the IMM.
- **Hard drive activity LED:** When this green LED is lit, it indicates that one of the hard disk drives is in use.

Notes:

1. For a SAS drive, a hard disk drive activity LED is shown in two places: on the hard disk drive and on the operator information panel.
2. For a SATA drive, hard disk drive activity is indicated only by the hard disk drive activity LED on the operator information panel.

Light path diagnostics panel

The light path diagnostics panel is located on the top of the operator information panel.

Note: The system service label on the underside of the cover also provides information about the location of the light path diagnostics LEDs.

To access the light path diagnostics panel, slide the blue release latch on the operator panel to the left. Pull forward on the panel until the hinge of the operator panel is free of the server chassis. Then pull down on the panel, so that you can view the light path diagnostics panel information.

Note: When you slide the light path diagnostics panel out of the server to check the LEDs or checkpoint codes, do not run the server continuously with light path diagnostics panel outside of the server. The panel should only be outside of the server a short time. The light path diagnostics panel must remain in the server when the server is running to ensure proper cooling.

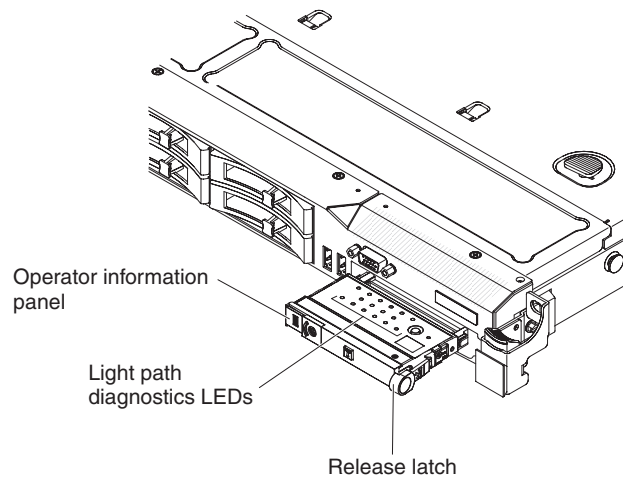

Figure 4. Light path diagnostics panel exposure

The following illustration shows the LEDs and controls on the light path diagnostics panel.

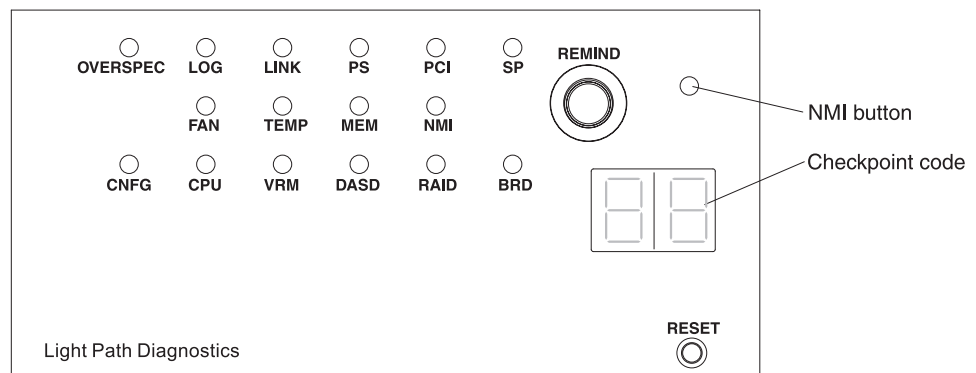

Figure 5. Light path diagnostics panel exposure

- **Remind button:** This button places the system-error LED on the front panel into Remind mode. In Remind mode, the system-error LED flashes every 2 seconds until the problem is corrected, the system is restarted, or a new problem occurs. By placing the system-error LED indicator in Remind mode, you acknowledge that you are aware of the last failure but will not take immediate action to correct the problem. The remind function is controlled by the IMM.
- **NMI button:** Press this button to force a nonmaskable interrupt to the microprocessor. It allows you to blue screen the server and take a memory dump (use this button only when directed by the IBM service support).
- **Checkpoint code display:** This display provides a checkpoint code that indicates the point at which the system stopped during the boot block and POST. A checkpoint code is either a byte or a word value that is produced by UEFI. The display does not provide error codes or suggest components to be replaced.
- **Reset button:** Press this button to reset the server and run the power-on self-test (POST). You might have to use a pen or the end of a straightened paper clip to press the button. The Reset button is in the lower right-hand corner of the light path diagnostics panel.

For additional information about the light path diagnostics panel LEDs, see “Light path diagnostics LEDs” on page 312.

Rear view

Use this information to view the controls, LEDs, and connectors on the rear of the server.

The following illustration shows the connectors and LEDs on the rear of the server.

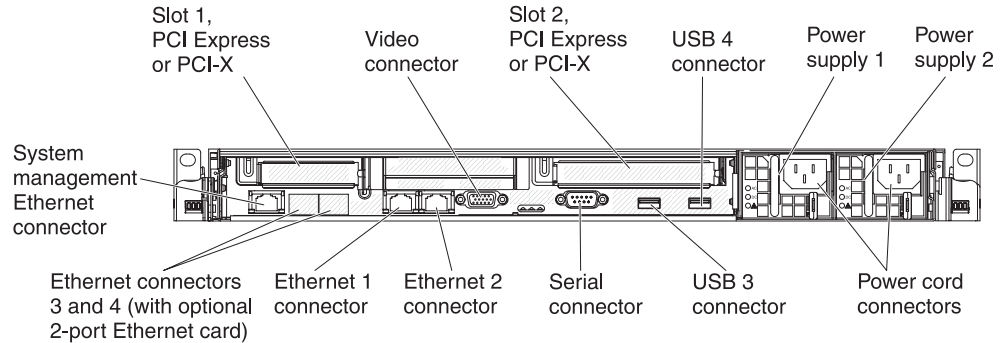

Figure 6. Rear view

- **PCI slot 1:** Insert a low-profile PCI Express or PCI-X adapter into this slot. You can purchase an optional PCI Express or PCI-X riser-card assembly with bracket if you want to install a PCI adapter in this slot.
- **PCI slot 2:** Insert a half-length, full-height PCI Express or PCI-X adapter into this slot. Standard models of the server come with one PCI Express riser-card assembly installed in this slot. You can purchase an optional PCI-X riser-card assembly with bracket if you want to install a PCI-X adapter in this slot.
- **Power cord connector:** Connect the power cord to this connector.
- **Video connector:** Connect a monitor to this connector. The video connectors on the front and rear of the server can be used simultaneously.

Note: The maximum video resolution is 1600 x 1200 at 75 Hz.

- **Serial connector:** Connect a 9-pin serial device to this connector. The serial port is shared with the integrated management module (IMM). The IMM can take control of the shared serial port to perform text console redirection and to redirect serial traffic, using Serial over LAN (SOL).
- **USB connectors:** Connect a USB device, such as a USB mouse or keyboard to any of these connectors.
- **Systems-management Ethernet connector:** Use this connector to connect the server to a network for full systems-management information control.
- **Ethernet connectors:** Use either of these connectors to connect the server to a network. When you use the Ethernet 1 connector, the network can be shared with the IMM through a single network cable.

The following illustration shows the LEDs on the rear of the server.

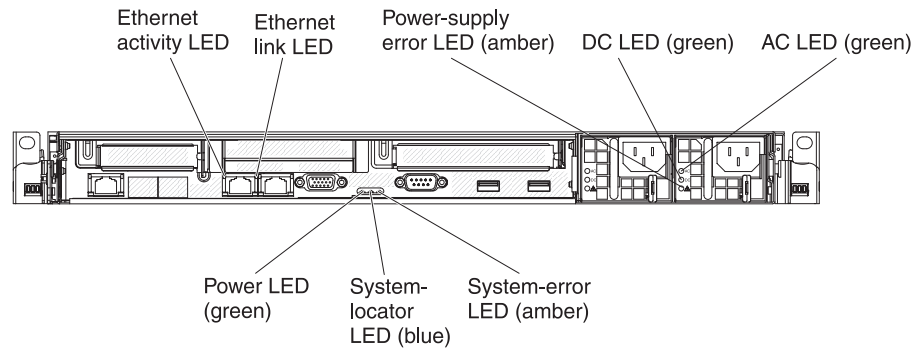

Figure 7. Rear view LEDs

The following illustration shows the LEDs on a dc power supply.

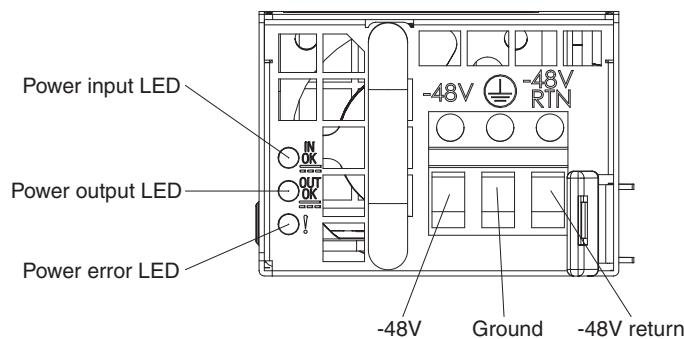

Figure 8. DC power supply LEDs

- **Ethernet activity LEDs:** When these LEDs are lit, they indicate that the server is transmitting to or receiving signals from the Ethernet LAN that is connected to the Ethernet port.
- **Ethernet link LEDs:** When these LEDs are lit, they indicate that there is an active link connection on the 10BASE-T, 100BASE-TX, or 1000BASE-TX interface for the Ethernet port.
- **AC power LED:** Each hot-swap ac power supply has an ac power LED and a dc power LED. When the ac power LED is lit, it indicates that sufficient power is coming into the power supply through the power cord. During typical operation, both the ac and dc power LEDs are lit. For any other combination of LEDs, see “Power-supply LEDs” on page 319.
- **IN OK power LED:** Each hot-swap dc power supply has an IN OK power LED and an OUT OK power LED. When the IN OK power LED is lit, it indicates that sufficient power is coming into the power supply through the power cord. During typical operation, both the IN OK and OUT OK power LEDs are lit. For any other combination of LEDs, see “Power-supply LEDs” on page 319.
- **DC power LED:** Each hot-swap power supply has a dc power LED and an ac power LED. When the dc power LED is lit, it indicates that the power supply is supplying adequate dc power to the system. During typical operation, both the ac and dc power LEDs are lit. For any other combination of LEDs, see “Power-supply LEDs” on page 319.
- **OUT OK power LED:** Each hot-swap dc power supply has an IN OK power LED and an OUT OK power LED. When the OUT OK power LED is lit, it indicates that the power supply is supplying adequate dc power to the system. During typical operation, both the IN OK and OUT OK power LEDs are lit. For any other combination of LEDs, see “Power-supply LEDs” on page 319.

- **Power-supply error LED:** When the power-supply error LED is lit, it indicates that the power supply has failed.

Note: Power supply 1 is the default/primary power supply. If power supply 1 fails, you must replace the power supply immediately.

- **System-error LED:** When this LED is lit, it indicates that a system error has occurred. An LED on the light path diagnostics panel is also lit to help isolate the error.
- **Power-on LED:** When this LED is lit and not flashing, it indicates that the server is turned on. The states of the power-on LED are as follows:

Off: Power is not present, or the power supply or the LED itself has failed.

Flashing rapidly (4 times per second): The server is turned off and is not ready to be turned on. The power-control button is disabled. This will last approximately 20 to 40 seconds.

Flashing slowly (once per second): The server is turned off and is ready to be turned on. You can press the power-control button to turn on the server.

Lit: The server is turned on.

Fading on and off: The server is in a reduced-power state. To wake the server, press the power-control button or use the IMM web interface. See “Logging on to the Web interface” on page 470 for information on logging on to the IMM web interface.

- **System-locator LED:** Use this LED to visually locate the server among other servers. You can use IBM Systems Director to light this LED remotely.

Server power features

When the server is connected to a power source but is not turned on, the operating system does not run, and all core logic except for the service processor (the integrated management module) is shut down; however, the server can respond to requests from the service processor, such as a remote request to turn on the server.

The power-on LED flashes to indicate that the server is connected to a power source but is not turned on.

Turning on the server

Use this information to turn on the server.

Approximately 5 seconds after the server is connected to power, one or more fans might start running to provide cooling while the server is connected to power and the power-on button LED will blink quickly. Approximately 20 to 40 seconds after the server is connected to power, the power-control button becomes active (the power-on LED will blink slowly), and one or more fans might start running to provide cooling while the server is connected to power. You can turn on the server by pressing the power-control button.

The server can also be turned on in any of the following ways:

- If a power failure occurs while the server is turned on, the server will restart automatically when power is restored.
- If your operating system supports the Wake on LAN feature, the Wake on LAN feature can turn on the server.

Note: When 4 GB or more of memory (physical or logical) is installed, some memory is reserved for various system resources and is unavailable to the operating system. The amount of memory that is reserved for system resources

depends on the operating system, the configuration of the server, and the configured PCI options.

Turning off the server

Use this information to turn off the server.

When you turn off the server and leave it connected to power, the server can respond to requests from the service processor, such as a remote request to turn on the server. While the server remains connected to power, one or more fans might continue to run. To remove all power from the server, you must disconnect it from the power source.

Some operating systems require an orderly shutdown before you turn off the server. See your operating-system documentation for information about shutting down the operating system.

Statement 5



CAUTION:

The power control button on the device and the power switch on the power supply do not turn off the electrical current supplied to the device. The device also might have more than one power cord. To remove all electrical current from the device, ensure that all power cords are disconnected from the power source.

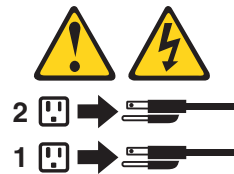

The server can be turned off in any of the following ways:

- You can turn off the server from the operating system, if your operating system supports this feature. After an orderly shutdown of the operating system, the server will turn off automatically.
- You can press the power-control button to start an orderly shutdown of the operating system and turn off the server, if your operating system supports this feature.
- If the operating system stops functioning, you can press and hold the power-control button for more than 4 seconds to turn off the server.
- The server can be turned off by Wake on LAN feature with the following limitation:
 - To install any PCI adapter, the power cords must be removed from the power source before you remove the PCI Express riser assembly and the PCI-X riser assembly. Otherwise, this will cause the active power management event signal to become disabled by the system board logic and Wake on LAN might not work. However, after the server is powered-on locally, the active power management event signal will be enabled by the system board logic.

- The integrated management module (IMM) can turn off the server as an automatic response to a critical system failure.

Internal LEDs, connectors, and jumpers

Use this information to view the internal LEDs, connectors, and jumpers.

The illustrations in this section show the connectors, LEDs, and jumpers on the internal boards.

Note: The illustrations might differ slightly from your hardware.

System-board internal connectors

The following illustration shows the internal connectors on the system board.

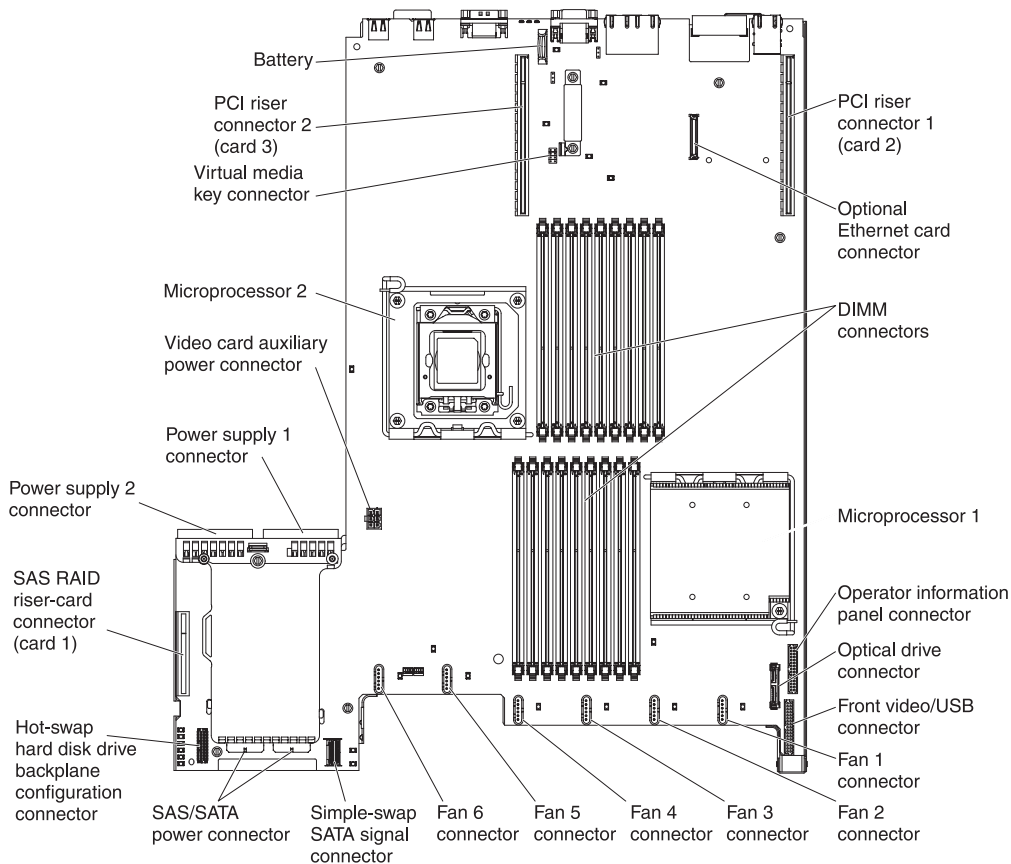

Figure 9. System-board internal connectors

System-board external connectors

The following illustration shows the external connectors on the system board.

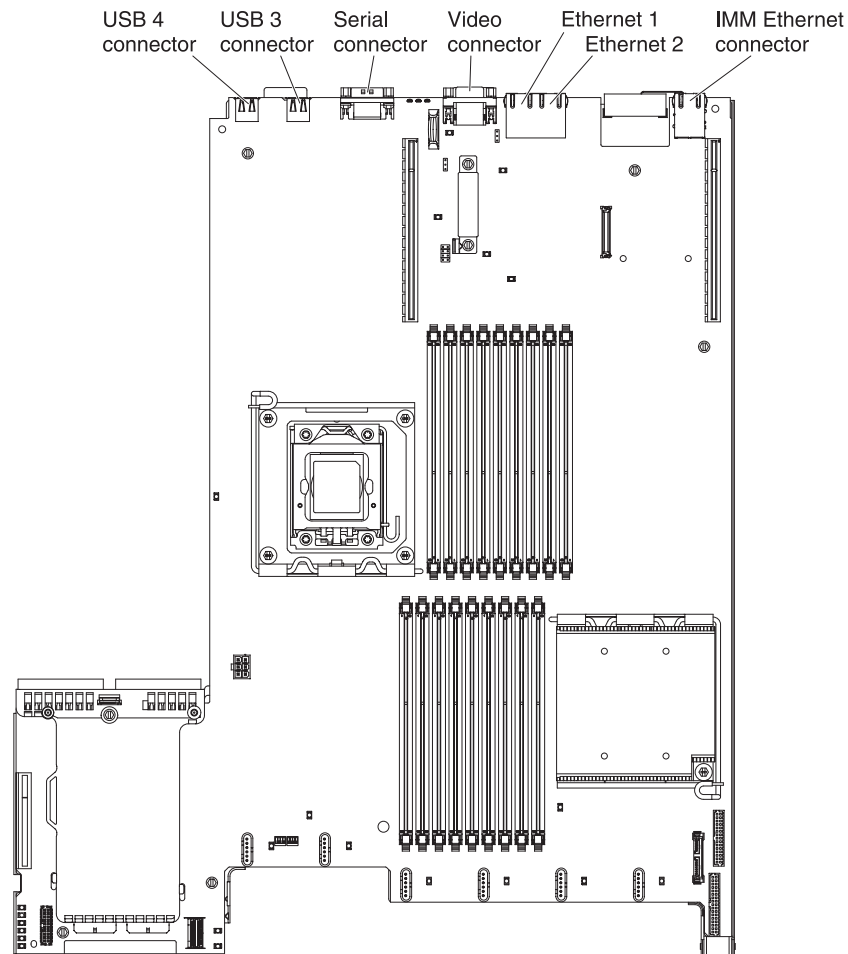

Figure 10. System-board external connectors

System-board switches and jumpers

The following illustration shows the location and description of the switches and jumpers.

Note: If there is a clear protective sticker on the top of the switch blocks, you must remove and discard it to access the switches.

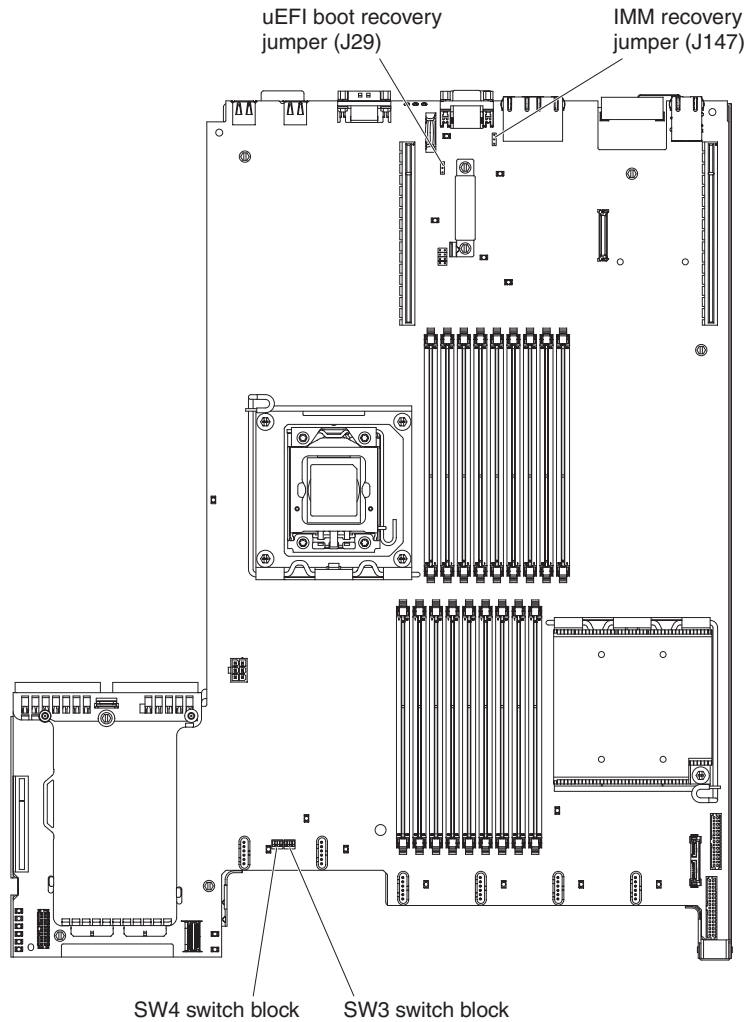

Figure 11. System-board switches and jumpers

Table 4. System board jumpers

Jumper number	Jumper name	Jumper setting
J29	UEFI boot recovery jumper	<ul style="list-style-type: none"> • Pins 1 and 2: Normal (default) Loads the primary server firmware ROM page. • Pins 2 and 3: Loads the secondary (backup) server firmware ROM page.
J147	IMM recovery jumper	<ul style="list-style-type: none"> • Pins 1 and 2: Normal (default) Loads the primary IMM firmware ROM page. • Pins 2 and 3: Loads the secondary (backup) IMM firmware ROM page.

Table 4. System board jumpers (continued)

Jumper number	Jumper name	Jumper setting
Table notes:		
1. If no jumper is present, the server responds as if the pins are set to 1 and 2.		
2. Changing the position of the UEFI boot recovery jumper (J29) from pins 1 and 2 to pins 2 and 3 before the server is turned on alters which flash ROM page is loaded. Do not change the jumper pin position after the server is turned on. This can cause an unpredictable problem.		

The following table describes the functions of the SW3 switch block on the system board.

Table 5. System board SW3 switch block definition

Switch number	Default position	Description
1	Off	Clear CMOS memory. When this switch is toggled to On, it clears the data in CMOS memory.
2	Off	Trust Platform Module (TPM) physical presence. Turning this switch to the on position indicates a physical presence to the TPM.
3	Off	Reserved.
4	Off	Reserved.

The following table describes the functions of the SW4 switch block on the system board.

Table 6. System board SW4 switch block definition

Switch number	Default position	Description
1	Off	<p>Power-on password override. Changing the position of this switch bypasses the power-on password check the next time the server is turned on and starts the Setup utility so that you can change or delete the power-on password. You do not have to move the switch back to the default position after the power-on password is overridden.</p> <p>Changing the position of this switch does not affect the administrator password check if an administrator password is set.</p> <p>See "Passwords" on page 464 for additional information about passwords.</p>

Table 6. System board SW4 switch block definition (continued)

Switch number	Default position	Description
2	Off	When you toggle this switch On and then Off, you force a power-on, which overrides the power-on and power-off button on the server and they become nonfunctional.
3	Off	(Trained service technician only) Forced power permission. Changing the position of this switch overrides the IMM power-on checking process.
4	Off	Reserved.

Important:

1. Before you change any switch settings or move any jumpers, turn off the server; then, disconnect all power cords and external cables. Review the information in “Safety” on page vii, “Installation guidelines” on page 347, “Handling static-sensitive devices” on page 350, and “Turning off the server” on page 17.
2. Any system-board switch or jumper blocks that are not shown in the illustrations in this document are reserved.

System-board LEDs

The following illustration shows the light-emitting diodes (LEDs) on the system board.

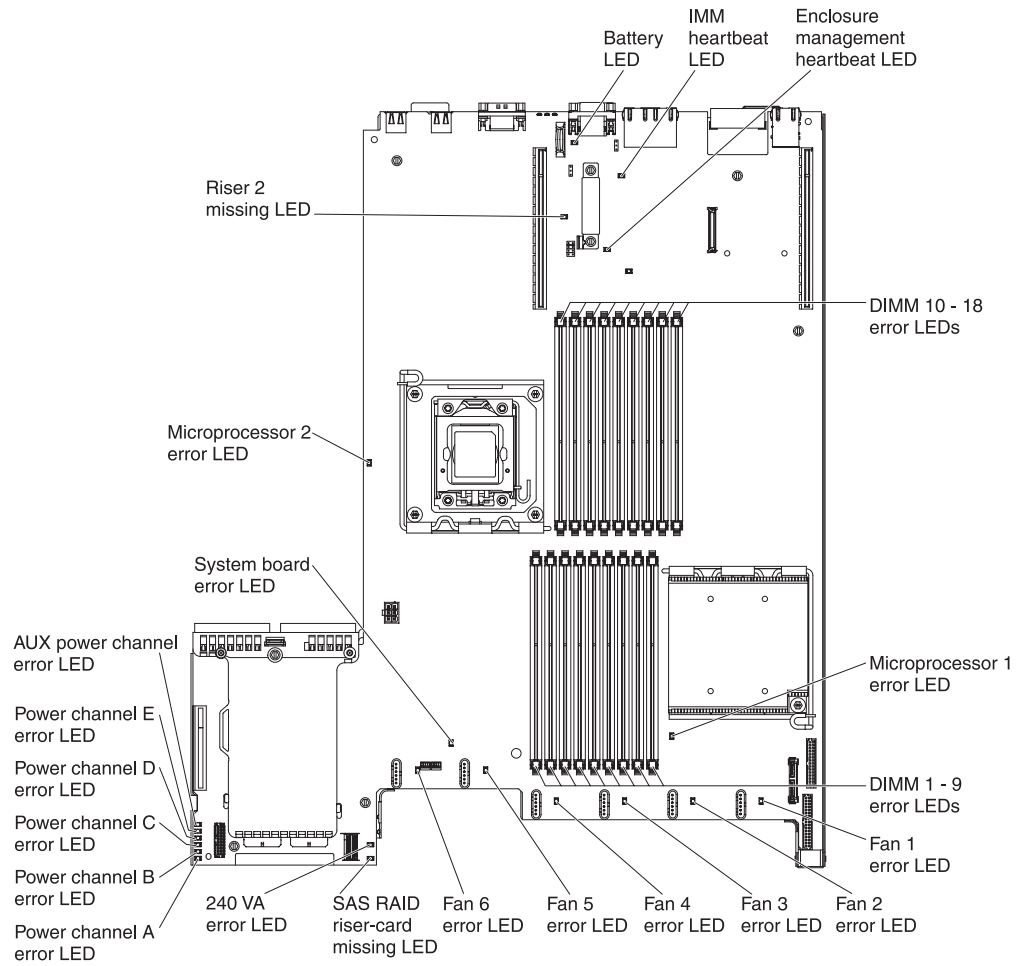

Figure 12. System-board LEDs

System-board optional device connectors

The following illustration shows the connectors for user-installable options.

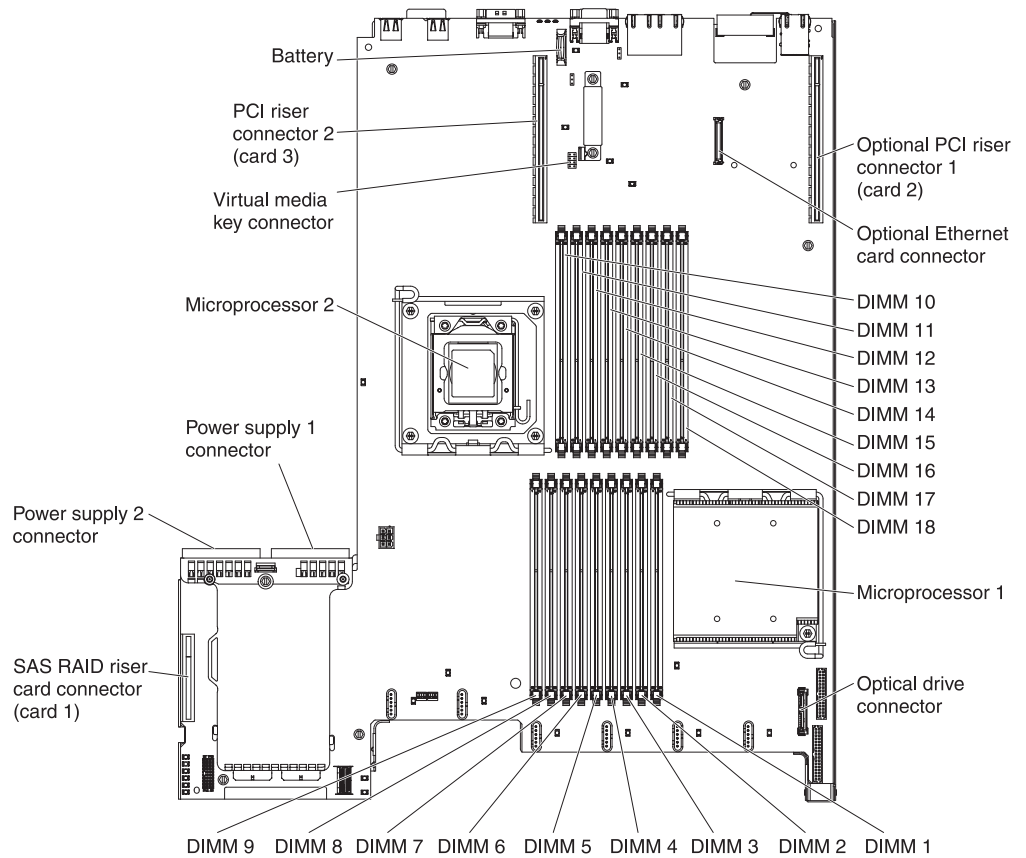

Figure 13. System-board optional device connectors

Chapter 3. Diagnostics

This chapter describes the diagnostic tools that are available to help you solve problems that might occur in the server.

If you cannot locate and correct a problem by using the information in this chapter, see “Getting help and technical assistance,” on page 483 for more information.

Diagnostic tools

The section introduces available tools to help you diagnose and solve hardware-related problems.

- **Light path diagnostics**

Use light path diagnostics to diagnose system errors quickly. See “Light path diagnostics” on page 309 for more information.

- **Dynamic System Analysis (DSA) Preboot diagnostic programs**

The DSA Preboot diagnostic programs provide problem isolation, configuration analysis, and error log collection. The diagnostic programs are the primary method of testing the major components of the server and are stored in integrated USB memory. The diagnostic programs collect the following information about the server:

- System configuration
- Network interfaces and settings
- Installed hardware
- Light path diagnostics status
- Service processor status and configuration
- Vital product data, firmware, and UEFI configuration
- Hard disk drive health
- RAID controller configuration
- Controller and service processor event logs, including the following information:
 - System error logs
 - Temperature, voltage, and fan speed information
 - Self-monitoring Analysis, and Reporting Technology (SMART) data
 - Machine check registers
 - USB information
 - Monitor configuration information
 - PCI slot information

The diagnostic programs create a merged log that includes events from all collected logs. The information is collected into a file that you can send to IBM service and support. Additionally, you can view the server information locally through a generated text report file. You can also copy the log to removable media and view the log from a web browser. See “Running the diagnostic programs” on page 255 for more information.

- **Troubleshooting tables**

These tables list problem symptoms and actions to correct the problems. See “Troubleshooting tables” on page 292 for more information.

- **IBM Electronic Service Agent**

IBM Electronic Service Agent is a software tool that monitors the server for hardware error events and automatically submits electronic service requests to IBM service and support. In addition, it can collect and transmit system configuration information on a scheduled basis so that the information is available to you and your support representative. It uses minimal system resources, and is available free of charge. For more information and to download IBM Electronic Service Agent, go to http://www.ibm.com/support/entry/portal/Open_service_request/.

- **POST error codes and event logs**

The power-on self-test (POST) generates messages to indicate successful test completion or the detection of a problem. For more information, see “Event logs” on page 27 and “POST” on page 242.

- **Checkpoint codes**

Checkpoint codes track the progress of POST routines at system startup or reset. Checkpoint codes are shown on the checkpoint code display, which is on the light path diagnostics panel.

Event logs

Error codes and messages are displayed in the following types of event logs. Some of the error codes and messages in the logs are abbreviated.

When you are troubleshooting PCI-X slots, note that the event logs report the PCI-X buses numerically. The numerical assignments vary depending on the configuration. You can check the assignments by running the Setup utility (see “Using the Setup utility” on page 460 for more information).

- **POST event log:** This log contains the three most recent error codes and messages that were generated during POST. You can view the contents of the POST event log through the Setup utility.
- **System-event log:** This log contains messages that were generated during POST and all system status messages from the service processor. You can view the contents of the system-event log from the Setup utility.

The system-event log is limited in size. When it is full, new entries will not overwrite existing entries; therefore, you must periodically clear the system-event log through the Setup utility. When you are troubleshooting an error, be sure to clear the system-event log so that you can find current errors more easily.

Each system-event log entry is displayed on its own page. Messages are listed on the left side of the screen, and details about the selected message are displayed on the right side of the screen. To move from one entry to the next, use the Up Arrow (↑) and Down Arrow (↓) keys.

The system-event log indicates an assertion event when an event has occurred. It indicates a deassertion event when the event is no longer occurring.

- **Integrated management module (IMM) event log:** This log contains a filtered subset of all IMM, POST, and system management interrupt (SMI) events. You can view the IMM event log through the IMM web interface and through the Dynamic System Analysis (DSA) program (as the ASM event log).
- **DSA log:** This log is generated by the Dynamic System Analysis (DSA) program, and it is a chronologically ordered merge of the system-event log (as the IPMI event log), the IMM chassis-event log (as the ASM event log), and the operating-system event logs. You can view the DSA log through the DSA program.

Viewing event logs from the Setup utility

Use this information to view event logs through the Setup utility.

About this task

To view the error logs, complete the following steps:

Procedure

1. Turn on the server.
2. When the prompt <F1> Setup is displayed, press F1. If you have set both a power-on password and an administrator password, you must type the administrator password to view the error logs.
3. Select **System Event Logs** and use one of the following procedures:
 - To view the POST event log, select **POST Event Viewers**.
 - To view the IMM system-event log, select **System Event Log**.

Viewing event logs without restarting the server

If the server is not hung, methods are available for you to view one or more event logs without having to restart the server.

If you have installed Dynamic System Analysis (DSA) Portable, you can use it to view the system-event log (as the IPMI event log), the IMM event log (as the ASM event log), the operating-system event logs, or the merged DSA log. You can also use DSA Preboot to view these logs, although you must restart the server to use DSA Preboot.

To install DSA Portable, DSA Preboot or to download a DSA Preboot CD image, go to <http://www.ibm.com/support/entry/portal/docdisplay?lnocid=SERV-DSA>.

If IPMItool is installed in the server, you can use it to view the system-event log. Most recent versions of the Linux operating system come with a current version of IPMItool.

For an overview of IPMI, go to <http://www.ibm.com/developerworks/linux/blueprints/> and click **Using Intelligent Platform Management Interface (IPMI) on IBM Linux platforms**.

You can view the IMM system event log through the **Event Log** link in the integrated management module (IMM) web interface. For more information, see "Logging on to the Web interface" on page 470.

The following table describes the methods that you can use to view the event logs, depending on the condition of the server. The first three conditions generally do not require that you restart the server.

Table 7. Methods for viewing event logs

Condition	Action
The server is not hung and is connected to a network.	Use any of the following methods: <ul style="list-style-type: none"> • Run DSA Portable to view the event logs or create an output file that you can send to a support representative. • In a web browser, type the IP address of the IMM and go to the Event Log page. • Use IPMItool to view the system-event log.
The server is not hung and is not connected to a network.	Use IPMItool locally to view the system-event log.
The server is not hung and the integrated management module (IMM) is connected to a network.	In a web browser, type the IP address for the IMM and go to the Event Log page. For more information, see “Obtaining the IP address for the IMM” on page 469 and “Logging on to the Web interface” on page 470.
The server is hung.	<ul style="list-style-type: none"> • If DSA Preboot is installed, restart the server and press F2 to start DSA Preboot and view the event logs. • If DSA Preboot is not installed, insert the DSA Preboot CD and restart the server to start DSA Preboot and view the event logs. • Alternatively, you can restart the server and press F1 to start the Setup utility and view the POST event log or system-event log. For more information, see “Viewing event logs from the Setup utility” on page 28.

Clearing the error logs

Use this information to clear the event logs.

About this task

To clear the error logs, complete the following steps:

Note: The POST error log is automatically cleared each time the server is restarted.

Procedure

1. Turn on the server.
2. When the prompt <F1> Setup is displayed, press F1. If you have set both a power-on password and an administrator password, you must type the administrator password to view the error logs.
3. To clear the IMM system-event log, select **System Event Logs > System Event Log > Clear System Event Log**, then, press Enter twice.

Error messages

This section provides the list of error codes and messages for UEFI/POST, IMM, and DSA that are generated when a problem is detected.

See “POST error codes” on page 242, “Integrated management module (IMM) error messages,” and “Diagnostic messages” on page 257 for more information.

System event log

There are three types of the system event log.

Information

Information messages do not require action; they record significant system-level events, such as when the server is started.

Warning

Warning messages do not require immediate action; they indicate possible problems, such as when the recommended maximum ambient temperature is exceeded.

Error Error messages might require action; they indicate system errors, such as when a fan is not detected.

Each message contains date and time information, and it indicates the source of the message (POST or the IMM).

Integrated management module (IMM) error messages

The following table describes the IMM error messages and suggested actions to correct the detected problems.

For more information about IMM, see the *Integrated Management Module User's Guide* at www.ibm.com/support/entry/portal/docdisplay?lnocid=MIGR-5079770&brandind=5000008.

Note: Deassertive events not listed in this table are informational only.

IMM Events that automatically notify Support:

You can configure the Integrated Management Module II (IMM2) to automatically notify Support (also known as *call home*) if certain types of errors are encountered. If you have configured this function, see the table for a list of events that automatically notify Support.

Table 8. Events that automatically notify Support

Event ID	Message String	Automatically Notify Support
80010202-0701xxxx	Numeric sensor [NumericSensorElementName] going low (lower critical) has asserted. (Planar 12V)	Yes
80010202-2801xxxx	Numeric sensor [NumericSensorElementName] going low (lower critical) has asserted. (CMOS Battery)	Yes

Table 8. Events that automatically notify Support (continued)

Event ID	Message String	Automatically Notify Support
80010902-0701xxxx	Numeric sensor [NumericSensorElementName] going high (upper critical) has asserted. (Planar 12V)	Yes
806f0021-2201xxxx	Fault in slot [PhysicalConnectorSystemElementName] on system [ComputerSystemElementName]. (No Op ROM Space)	Yes
806f0021-2582xxxx	Fault in slot [PhysicalConnectorSystemElementName] on system [ComputerSystemElementName]. (All PCI Error)	Yes
806f0021-3001xxxx	Fault in slot [PhysicalConnectorSystemElementName] on system [ComputerSystemElementName]. (PCI 1)	Yes
806f0108-0a01xxxx	[PowerSupplyElementName] has Failed. (Power Supply 1)	Yes
806f0108-0a02xxxx	[PowerSupplyElementName] has Failed. (Power Supply 2)	Yes
806f010c-2001xxxx	Uncorrectable error detected for [PhysicalMemoryElementName] on Subsystem [MemoryElementName]. (DIMM 1)	Yes
806f010c-2002xxxx	Uncorrectable error detected for [PhysicalMemoryElementName] on Subsystem [MemoryElementName]. (DIMM 2)	Yes
806f010c-2003xxxx	Uncorrectable error detected for [PhysicalMemoryElementName] on Subsystem [MemoryElementName]. (DIMM 3)	Yes
806f010c-2004xxxx	Uncorrectable error detected for [PhysicalMemoryElementName] on Subsystem [MemoryElementName]. (DIMM 4)	Yes
806f010c-2005xxxx	Uncorrectable error detected for [PhysicalMemoryElementName] on Subsystem [MemoryElementName]. (DIMM 5)	Yes
806f010c-2006xxxx	Uncorrectable error detected for [PhysicalMemoryElementName] on Subsystem [MemoryElementName]. (DIMM 6)	Yes
806f010c-2007xxxx	Uncorrectable error detected for [PhysicalMemoryElementName] on Subsystem [MemoryElementName]. (DIMM 7)	Yes

Table 8. Events that automatically notify Support (continued)

Event ID	Message String	Automatically Notify Support
806f010c-2008xxxx	Uncorrectable error detected for [PhysicalMemoryElementName] on Subsystem [MemoryElementName]. (DIMM 8)	Yes
806f010c-2009xxxx	Uncorrectable error detected for [PhysicalMemoryElementName] on Subsystem [MemoryElementName]. (DIMM 9)	Yes
806f010c-200axxxx	Uncorrectable error detected for [PhysicalMemoryElementName] on Subsystem [MemoryElementName]. (DIMM 10)	Yes
806f010c-200bxxxx	Uncorrectable error detected for [PhysicalMemoryElementName] on Subsystem [MemoryElementName]. (DIMM 11)	Yes
806f010c-200cxxxx	Uncorrectable error detected for [PhysicalMemoryElementName] on Subsystem [MemoryElementName]. (DIMM 12)	Yes
806f010c-200dxxxx	Uncorrectable error detected for [PhysicalMemoryElementName] on Subsystem [MemoryElementName]. (DIMM 13)	Yes
806f010c-200exxxx	Uncorrectable error detected for [PhysicalMemoryElementName] on Subsystem [MemoryElementName]. (DIMM 14)	Yes
806f010c-200fxxxx	Uncorrectable error detected for [PhysicalMemoryElementName] on Subsystem [MemoryElementName]. (DIMM 15)	Yes
806f010c-2010xxxx	Uncorrectable error detected for [PhysicalMemoryElementName] on Subsystem [MemoryElementName]. (DIMM 16)	Yes
806f010c-2011xxxx	Uncorrectable error detected for [PhysicalMemoryElementName] on Subsystem [MemoryElementName]. (DIMM 17)	Yes
806f010c-2012xxxx	Uncorrectable error detected for [PhysicalMemoryElementName] on Subsystem [MemoryElementName]. (DIMM 18)	Yes
806f010c-2581xxxx	Uncorrectable error detected for [PhysicalMemoryElementName] on Subsystem [MemoryElementName]. (All DIMMS)	Yes

Table 8. Events that automatically notify Support (continued)

Event ID	Message String	Automatically Notify Support
806f010d-0400xxxx	The Drive [StorageVolumeElementName] has been disabled due to a detected fault. (Drive 0)	Yes
806f010d-0401xxxx	The Drive [StorageVolumeElementName] has been disabled due to a detected fault. (Drive 1)	Yes
806f010d-0402xxxx	The Drive [StorageVolumeElementName] has been disabled due to a detected fault. (Drive 2)	Yes
806f010d-0403xxxx	The Drive [StorageVolumeElementName] has been disabled due to a detected fault. (Drive 3)	Yes
806f010d-0404xxxx	The Drive [StorageVolumeElementName] has been disabled due to a detected fault. (Drive 4)	Yes
806f010d-0405xxxx	The Drive [StorageVolumeElementName] has been disabled due to a detected fault. (Drive 5)	Yes
806f010d-0406xxxx	The Drive [StorageVolumeElementName] has been disabled due to a detected fault. (Drive 6)	Yes
806f010d-0407xxxx	The Drive [StorageVolumeElementName] has been disabled due to a detected fault. (Drive 7)	Yes
806f011b-0701xxxx	The connector [PhysicalConnectorElementName] has encountered a configuration error. (Video USB)	Yes
806f0207-0301xxxx	[ProcessorElementName] has Failed with FRB1/BIST condition. (CPU 1)	Yes
806f0207-0302xxxx	[ProcessorElementName] has Failed with FRB1/BIST condition. (CPU 2)	Yes
806f020d-0400xxxx	Failure Predicted on drive [StorageVolumeElementName] for array [ComputerSystemElementName]. (Drive 0)	Yes
806f020d-0401xxxx	Failure Predicted on drive [StorageVolumeElementName] for array [ComputerSystemElementName]. (Drive 1)	Yes
806f020d-0402xxxx	Failure Predicted on drive [StorageVolumeElementName] for array [ComputerSystemElementName]. (Drive 2)	Yes
806f020d-0403xxxx	Failure Predicted on drive [StorageVolumeElementName] for array [ComputerSystemElementName]. (Drive 3)	Yes
806f020d-0404xxxx	Failure Predicted on drive [StorageVolumeElementName] for array [ComputerSystemElementName]. (Drive 4)	Yes

Table 8. Events that automatically notify Support (continued)

Event ID	Message String	Automatically Notify Support
806f020d-0405xxxx	Failure Predicted on drive [StorageVolumeElementName] for array [ComputerSystemElementName]. (Drive 5)	Yes
806f020d-0406xxxx	Failure Predicted on drive [StorageVolumeElementName] for array [ComputerSystemElementName]. (Drive 6)	Yes
806f020d-0407xxxx	Failure Predicted on drive [StorageVolumeElementName] for array [ComputerSystemElementName]. (Drive 7)	Yes
806f0212-2584xxxx	The System [ComputerSystemElementName] has encountered an unknown system hardware fault. (CPU Fault Reboot)	Yes
806f050c-2001xxxx	Memory Logging Limit Reached for [PhysicalMemoryElementName] on Subsystem [MemoryElementName]. (DIMM 1)	Yes
806f050c-2002xxxx	Memory Logging Limit Reached for [PhysicalMemoryElementName] on Subsystem [MemoryElementName]. (DIMM 2)	Yes
806f050c-2003xxxx	Memory Logging Limit Reached for [PhysicalMemoryElementName] on Subsystem [MemoryElementName]. (DIMM 3)	Yes
806f050c-2004xxxx	Memory Logging Limit Reached for [PhysicalMemoryElementName] on Subsystem [MemoryElementName]. (DIMM 4)	Yes
806f050c-2005xxxx	Memory Logging Limit Reached for [PhysicalMemoryElementName] on Subsystem [MemoryElementName]. (DIMM 5)	Yes
806f050c-2006xxxx	Memory Logging Limit Reached for [PhysicalMemoryElementName] on Subsystem [MemoryElementName]. (DIMM 6)	Yes
806f050c-2007xxxx	Memory Logging Limit Reached for [PhysicalMemoryElementName] on Subsystem [MemoryElementName]. (DIMM 7)	Yes
806f050c-2008xxxx	Memory Logging Limit Reached for [PhysicalMemoryElementName] on Subsystem [MemoryElementName]. (DIMM 8)	Yes
806f050c-2009xxxx	Memory Logging Limit Reached for [PhysicalMemoryElementName] on Subsystem [MemoryElementName]. (DIMM 9)	Yes

Table 8. Events that automatically notify Support (continued)

Event ID	Message String	Automatically Notify Support
806f050c-200axxxx	Memory Logging Limit Reached for [PhysicalMemoryElementName] on Subsystem [MemoryElementName]. (DIMM 10)	Yes
806f050c-200bxxxx	Memory Logging Limit Reached for [PhysicalMemoryElementName] on Subsystem [MemoryElementName]. (DIMM 11)	Yes
806f050c-200cxxxx	Memory Logging Limit Reached for [PhysicalMemoryElementName] on Subsystem [MemoryElementName]. (DIMM 12)	Yes
806f050c-200dxxxx	Memory Logging Limit Reached for [PhysicalMemoryElementName] on Subsystem [MemoryElementName]. (DIMM 13)	Yes
806f050c-200exxxx	Memory Logging Limit Reached for [PhysicalMemoryElementName] on Subsystem [MemoryElementName]. (DIMM 14)	Yes
806f050c-200fxxxx	Memory Logging Limit Reached for [PhysicalMemoryElementName] on Subsystem [MemoryElementName]. (DIMM 15)	Yes
806f050c-2010xxxx	Memory Logging Limit Reached for [PhysicalMemoryElementName] on Subsystem [MemoryElementName]. (DIMM 16)	Yes
806f050c-2011xxxx	Memory Logging Limit Reached for [PhysicalMemoryElementName] on Subsystem [MemoryElementName]. (DIMM 17)	Yes
806f050c-2012xxxx	Memory Logging Limit Reached for [PhysicalMemoryElementName] on Subsystem [MemoryElementName]. (DIMM 18)	Yes
806f050c-2581xxxx	Memory Logging Limit Reached for [PhysicalMemoryElementName] on Subsystem [MemoryElementName]. (All DIMMS)	Yes
806f060d-0400xxxx	Array [ComputerSystemElementName] has failed. (Drive 0)	Yes
806f060d-0401xxxx	Array [ComputerSystemElementName] has failed. (Drive 1)	Yes
806f060d-0402xxxx	Array [ComputerSystemElementName] has failed. (Drive 2)	Yes
806f060d-0403xxxx	Array [ComputerSystemElementName] has failed. (Drive 3)	Yes

Table 8. Events that automatically notify Support (continued)

Event ID	Message String	Automatically Notify Support
806f060d-0404xxxx	Array [ComputerSystemElementName] has failed. (Drive 4)	Yes
806f060d-0405xxxx	Array [ComputerSystemElementName] has failed. (Drive 5)	Yes
806f060d-0406xxxx	Array [ComputerSystemElementName] has failed. (Drive 6)	Yes
806f060d-0407xxxx	Array [ComputerSystemElementName] has failed. (Drive 7)	Yes
806f0813-2581xxxx	A Uncorrectable Bus Error has occurred on system [ComputerSystemElementName]. (DIMMs)	Yes
806f0813-2582xxxx	A Uncorrectable Bus Error has occurred on system [ComputerSystemElementName]. (PCIs)	Yes
806f0813-2584xxxx	A Uncorrectable Bus Error has occurred on system [ComputerSystemElementName]. (CPUs)	Yes

40000001-00000000 Management Controller [arg1] Network Initialization Complete.

Explanation: This message is for the use case where a Management Controller network has completed initialization.

May also be shown as 4000000100000000 or 0x4000000100000000

Severity: Info

Alert Category: System - IMM Network event

Serviceable: No

CIM Information: Prefix: IMM and ID: 0001

SNMP Trap ID: 37

Automatically notify Support: No

User response: Information only; no action is required.

40000002-00000000 Certificate Authority [arg1] has detected a [arg2] Certificate Error.

Explanation: This message is for the use case when there is an error with an SSL Server, SSL Client, or SSL Trusted CA Certificate.

May also be shown as 4000000200000000 or 0x4000000200000000

Severity: Error

Alert Category: System - other

Serviceable: No

CIM Information: Prefix: IMM and ID: 0002

SNMP Trap ID: 22

Automatically notify Support: No

User response: Make sure that the certificate that you are importing is correct and properly generated.

40000003-00000000 Ethernet Data Rate modified from [arg1] to [arg2] by user [arg3].

Explanation: This message is for the use case where a client modifies the Ethernet Port data rate.

May also be shown as 4000000300000000 or 0x4000000300000000

Severity: Info

Alert Category: none

Serviceable: No

CIM Information: Prefix: IMM and ID: 0003

SNMP Trap ID:

Automatically notify Support: No

User response: Information only; no action is required.

40000004-00000000 Ethernet Duplex setting modified from [arg1] to [arg2] by user [arg3].

Explanation: This message is for the use case where a client modifies the Ethernet Port duplex setting.

May also be shown as 4000000400000000 or 0x4000000400000000

Severity: Info

Alert Category: none

Serviceable: No

CIM Information: Prefix: IMM and ID: 0004

SNMP Trap ID:

Automatically notify Support: No

User response: Information only; no action is required.

40000005-00000000 Ethernet MTU setting modified from [arg1] to [arg2] by user [arg3].

Explanation: This message is for the use case where a client modifies the Ethernet Port MTU setting.

May also be shown as 4000000500000000 or 0x4000000500000000

Severity: Info

Alert Category: none

Serviceable: No

CIM Information: Prefix: IMM and ID: 0005

SNMP Trap ID:

Automatically notify Support: No

User response: Information only; no action is required.

40000006-00000000 • 40000008-00000000

40000006-00000000 Ethernet locally administered MAC address modified from [arg1] to [arg2] by user [arg3].

Explanation: This message is for the use case where a client modifies the Ethernet Port MAC address setting.

May also be shown as 4000000600000000 or 0x4000000600000000

Severity: Info

Alert Category: none

Serviceable: No

CIM Information: Prefix: IMM and ID: 0006

SNMP Trap ID:

Automatically notify Support: No

User response: Information only; no action is required.

40000007-00000000 Ethernet interface [arg1] by user [arg2].

Explanation: This message is for the use case where a client enables or disabled the ethernet interface.

May also be shown as 4000000700000000 or 0x4000000700000000

Severity: Info

Alert Category: none

Serviceable: No

CIM Information: Prefix: IMM and ID: 0007

SNMP Trap ID:

Automatically notify Support: No

User response: Information only; no action is required.

40000008-00000000 Hostname set to [arg1] by user [arg2].

Explanation: This message is for the use case where a client modifies the Hostname of a Management Controller.

May also be shown as 4000000800000000 or 0x4000000800000000

Severity: Info

Alert Category: System - IMM Network event

Serviceable: No

CIM Information: Prefix: IMM and ID: 0008

SNMP Trap ID: 37

Automatically notify Support: No

User response: Information only; no action is required.

40000009-00000000 IP address of network interface modified from [arg1] to [arg2] by user [arg3].

Explanation: This message is for the use case where a client modifies the IP address of a Management Controller.

May also be shown as 4000000900000000 or 0x4000000900000000

Severity: Info

Alert Category: System - IMM Network event

Serviceable: No

CIM Information: Prefix: IMM and ID: 0009

SNMP Trap ID: 37

Automatically notify Support: No

User response: Information only; no action is required.

4000000a-00000000 IP subnet mask of network interface modified from [arg1] to [arg2] by user [arg3].

Explanation: This message is for the use case where a client modifies the IP subnet mask of a Management Controller.

May also be shown as 4000000a00000000 or 0x4000000a00000000

Severity: Info

Alert Category: none

Serviceable: No

CIM Information: Prefix: IMM and ID: 0010

SNMP Trap ID:

Automatically notify Support: No

User response: Information only; no action is required.

4000000b-00000000 IP address of default gateway modified from [arg1] to [arg2] by user [arg3].

Explanation: This message is for the use case where a client modifies the default gateway IP address of a Management Controller.

May also be shown as 4000000b00000000 or 0x4000000b00000000

Severity: Info

Alert Category: none

Serviceable: No

CIM Information: Prefix: IMM and ID: 0011

SNMP Trap ID:

Automatically notify Support: No

User response: Information only; no action is required.

4000000c-00000000 • 4000000e-00000000

4000000c-00000000 OS Watchdog response [arg1] by [arg2] .

Explanation: This message is for the use case where an OS Watchdog has been enabled or disabled by a client.

May also be shown as 4000000c00000000 or 0x4000000c00000000

Severity: Info

Alert Category: none

Serviceable: No

CIM Information: Prefix: IMM and ID: 0012

SNMP Trap ID:

Automatically notify Support: No

User response: Information only; no action is required.

4000000d-00000000 DHCP[[arg1]] failure, no IP address assigned.

Explanation: This message is for the use case where a DHCP server fails to assign an IP address to a Management Controller.

May also be shown as 4000000d00000000 or 0x4000000d00000000

Severity: Warning

Alert Category: none

Serviceable: No

CIM Information: Prefix: IMM and ID: 0013

SNMP Trap ID:

Automatically notify Support: No

User response: Complete the following steps until the problem is solved: Make sure that the IMM network cable is connected. Make sure that there is a DHCP server on the network that can assign an IP address to the IMM.

4000000e-00000000 Remote Login Successful. Login ID: [arg1] from [arg2] at IP address [arg3].

Explanation: This message is for the use case where a client successfully logs in to a Management Controller.

May also be shown as 4000000e00000000 or 0x4000000e00000000

Severity: Info

Alert Category: System - Remote Login

Serviceable: No

CIM Information: Prefix: IMM and ID: 0014

SNMP Trap ID: 30

Automatically notify Support: No

User response: Information only; no action is required.

4000000f-00000000 Attempting to [arg1] server [arg2] by user [arg3].

Explanation: This message is for the use case where a client is using the Management Controller to perform a power function on the system.

May also be shown as 4000000f00000000 or 0x4000000f00000000

Severity: Info

Alert Category: none

Serviceable: No

CIM Information: Prefix: IMM and ID: 0015

SNMP Trap ID:

Automatically notify Support: No

User response: Information only; no action is required.

40000010-00000000 Security: Userid: [arg1] had [arg2] login failures from WEB client at IP address [arg3].

Explanation: This message is for the use case where a client has failed to log in to a Management Controller from a web browser.

May also be shown as 4000001000000000 or 0x4000001000000000

Severity: Warning

Alert Category: System - Remote Login

Serviceable: No

CIM Information: Prefix: IMM and ID: 0016

SNMP Trap ID: 30

Automatically notify Support: No

User response: Complete the following steps until the problem is solved: Make sure that the correct login ID and password are being used. Have the system administrator reset the login ID or password.

40000011-00000000 Security: Login ID: [arg1] had [arg2] login failures from CLI at [arg3].

Explanation: This message is for the use case where a client has failed to log in to a Management Controller from the Legacy CLI.

May also be shown as 4000001100000000 or 0x4000001100000000

Severity: Warning

Alert Category: System - Remote Login

Serviceable: No

CIM Information: Prefix: IMM and ID: 0017

SNMP Trap ID: 30

Automatically notify Support: No

User response: Complete the following steps until the problem is solved: Make sure that the correct login ID and password are being used. Have the system administrator reset the login ID or password.

40000012-00000000 • 40000014-00000000

40000012-00000000 Remote access attempt failed. Invalid userid or password received. Userid is [arg1] from WEB browser at IP address [arg2].

Explanation: This message is for the use case where a client has failed to log in to a Management Controller from a web browser.

May also be shown as 4000001200000000 or 0x4000001200000000

Severity: Info

Alert Category: System - Remote Login

Serviceable: No

CIM Information: Prefix: IMM and ID: 0018

SNMP Trap ID: 30

Automatically notify Support: No

User response: Make sure that the correct login ID and password are being used.

40000013-00000000 Remote access attempt failed. Invalid userid or password received. Userid is [arg1] from TELNET client at IP address [arg2].

Explanation: This message is for the use case where a client has failed to log in to a Management Controller from a telnet session.

May also be shown as 4000001300000000 or 0x4000001300000000

Severity: Info

Alert Category: System - Remote Login

Serviceable: No

CIM Information: Prefix: IMM and ID: 0019

SNMP Trap ID: 30

Automatically notify Support: No

User response: Make sure that the correct login ID and password are being used.

40000014-00000000 The [arg1] on system [arg2] cleared by user [arg3].

Explanation: This message is for the use case where a Management Controller Event Log on a system is cleared by a user.

May also be shown as 4000001400000000 or 0x4000001400000000

Severity: Info

Alert Category: none

Serviceable: No

CIM Information: Prefix: IMM and ID: 0020

SNMP Trap ID:

Automatically notify Support: No

User response: Information only; no action is required.

40000015-00000000 Management Controller [arg1] reset was initiated by user [arg2].

Explanation: This message is for the use case where a Management Controller reset is initiated by a user.

May also be shown as 4000001500000000 or 0x4000001500000000

Severity: Info

Alert Category: none

Serviceable: No

CIM Information: Prefix: IMM and ID: 0021

SNMP Trap ID:

Automatically notify Support: No

User response: Information only; no action is required.

40000016-00000000 ENET[[arg1]] DHCP-HSTN=[arg2], DN=[arg3], IP@[arg4], SN=[arg5], GW@[arg6],
DNS1@[arg7] .

Explanation: This message is for the use case where a Management Controller IP address and configuration has been assigned by the DHCP server.

May also be shown as 4000001600000000 or 0x4000001600000000

Severity: Info

Alert Category: none

Serviceable: No

CIM Information: Prefix: IMM and ID: 0022

SNMP Trap ID:

Automatically notify Support: No

User response: Information only; no action is required.

40000017-00000000 ENET[[arg1]] IP-Cfg:HstName=[arg2], IP@[arg3] ,NetMsk=[arg4], GW@[arg5] .

Explanation: This message is for the use case where a Management Controller IP address and configuration has been assigned statically using client data.

May also be shown as 4000001700000000 or 0x4000001700000000

Severity: Info

Alert Category: none

Serviceable: No

CIM Information: Prefix: IMM and ID: 0023

SNMP Trap ID:

Automatically notify Support: No

User response: Information only; no action is required.

40000018-00000000 • 4000001a-00000000

40000018-00000000 LAN: Ethernet[[arg1]] interface is no longer active.

Explanation: This message is for the use case where a Management Controller ethernet interface is no longer active.

May also be shown as 4000001800000000 or 0x4000001800000000

Severity: Info

Alert Category: none

Serviceable: No

CIM Information: Prefix: IMM and ID: 0024

SNMP Trap ID:

Automatically notify Support: No

User response: Information only; no action is required.

40000019-00000000 LAN: Ethernet[[arg1]] interface is now active.

Explanation: This message is for the use case where a Management Controller ethernet interface is now active.

May also be shown as 4000001900000000 or 0x4000001900000000

Severity: Info

Alert Category: none

Serviceable: No

CIM Information: Prefix: IMM and ID: 0025

SNMP Trap ID:

Automatically notify Support: No

User response: Information only; no action is required.

4000001a-00000000 DHCP setting changed to [arg1] by user [arg2].

Explanation: This message is for the use case where a client changes the DHCP setting.

May also be shown as 4000001a00000000 or 0x4000001a00000000

Severity: Info

Alert Category: none

Serviceable: No

CIM Information: Prefix: IMM and ID: 0026

SNMP Trap ID:

Automatically notify Support: No

User response: Information only; no action is required.

4000001b-00000000 Management Controller [arg1]: Configuration restored from a file by user [arg2].

Explanation: This message is for the use case where a client restores a Management Controller configuration from a file.

May also be shown as 4000001b00000000 or 0x4000001b00000000

Severity: Info

Alert Category: none

Serviceable: No

CIM Information: Prefix: IMM and ID: 0027

SNMP Trap ID:

Automatically notify Support: No

User response: Information only; no action is required.

4000001c-00000000 Watchdog [arg1] Screen Capture Occurred .

Explanation: This message is for the use case where an operating system error has occurred and the screen was captured.

May also be shown as 4000001c00000000 or 0x4000001c00000000

Severity: Info

Alert Category: System - other

Serviceable: No

CIM Information: Prefix: IMM and ID: 0028

SNMP Trap ID: 22

Automatically notify Support: No

User response: If there was no operating-system error, complete the following steps until the problem is solved: Reconfigure the watchdog timer to a higher value. Make sure that the IMM Ethernet-over-USB interface is enabled. Reinstall the RNDIS or cdc_ether device driver for the operating system. Disable the watchdog. If there was an operating-system error, check the integrity of the installed operating system.

4000001d-00000000 Watchdog [arg1] Failed to Capture Screen.

Explanation: This message is for the use case where an operating system error has occurred and the screen capture failed.

May also be shown as 4000001d00000000 or 0x4000001d00000000

Severity: Error

Alert Category: System - other

Serviceable: No

CIM Information: Prefix: IMM and ID: 0029

SNMP Trap ID: 22

Automatically notify Support: No

User response: Complete the following steps until the problem is solved: Reconfigure the watchdog timer to a higher value. Make sure that the IMM Ethernet over USB interface is enabled. Reinstall the RNDIS or cdc_ether device driver for the operating system. Disable the watchdog. Check the integrity of the installed operating system. Update the IMM firmware. Important: Some cluster solutions require specific code levels or coordinated code updates. If the device is part of a cluster solution, verify that the latest level of code is supported for the cluster solution before you update the code.

4000001e-00000000 Running the backup Management Controller [arg1] main application.

Explanation: This message is for the use case where a Management Controller has resorted to running the backup main application.

May also be shown as 4000001e00000000 or 0x4000001e00000000

Severity: Warning

Alert Category: System - other

Serviceable: No

CIM Information: Prefix: IMM and ID: 0030

SNMP Trap ID: 22

Automatically notify Support: No

User response: Update the IMM firmware. Important: Some cluster solutions require specific code levels or coordinated code updates. If the device is part of a cluster solution, verify that the latest level of code is supported for the cluster solution before you update the code.

4000001f-00000000 Please ensure that the Management Controller [arg1] is flashed with the correct firmware. The Management Controller is unable to match its firmware to the server.

Explanation: This message is for the use case where a Management Controller firmware version does not match the server.

May also be shown as 4000001f00000000 or 0x4000001f00000000

Severity: Error

Alert Category: System - other

Serviceable: No

CIM Information: Prefix: IMM and ID: 0031

SNMP Trap ID: 22

Automatically notify Support: No

User response: Update the IMM firmware to a version that the server supports. Important: Some cluster solutions require specific code levels or coordinated code updates. If the device is part of a cluster solution, verify that the latest level of code is supported for the cluster solution before you update the code.

40000020-00000000 Management Controller [arg1] Reset was caused by restoring default values.

Explanation: This message is for the use case where a Management Controller has been reset due to a client restoring the configuration to default values.

May also be shown as 4000002000000000 or 0x4000002000000000

Severity: Info

Alert Category: none

Serviceable: No

CIM Information: Prefix: IMM and ID: 0032

SNMP Trap ID:

Automatically notify Support: No

User response: Information only; no action is required.

40000021-00000000 Management Controller [arg1] clock has been set from NTP server [arg2].

Explanation: This message is for the use case where a Management Controller clock has been set from the Network Time Protocol server.

May also be shown as 4000002100000000 or 0x4000002100000000

Severity: Info

Alert Category: none

Serviceable: No

CIM Information: Prefix: IMM and ID: 0033

SNMP Trap ID:

Automatically notify Support: No

User response: Information only; no action is required.

40000022-00000000 SSL data in the Management Controller [arg1] configuration data is invalid. Clearing configuration data region and disabling SSL.

Explanation: This message is for the use case where a Management Controller has detected invalid SSL data in the configuration data and is clearing the configuration data region and disabling the SSL.

May also be shown as 4000002200000000 or 0x4000002200000000

Severity: Error

Alert Category: System - other

Serviceable: No

CIM Information: Prefix: IMM and ID: 0034

SNMP Trap ID: 22

Automatically notify Support: No

User response: Complete the following steps until the problem is solved: Make sure that the certificate that you are importing is correct. Try to import the certificate again.

40000023-00000000 Flash of [arg1] from [arg2] succeeded for user [arg3] .

Explanation: This message is for the use case where a client has successfully flashed the firmware component (MC Main Application, MC Boot ROM, BIOS, Diagnostics, System Power Backplane, Remote Expansion Enclosure Power Backplane, Integrated System Management Processor, or Remote Expansion Enclosure Processor) from the interface and IP address (%d).

May also be shown as 4000002300000000 or 0x4000002300000000

Severity: Info

Alert Category: none

Serviceable: No

CIM Information: Prefix: IMM and ID: 0035

SNMP Trap ID:

Automatically notify Support: No

User response: Information only; no action is required.

40000024-00000000 • 40000026-00000000

40000024-00000000 Flash of [arg1] from [arg2] failed for user [arg3].

Explanation: This message is for the use case where a client has not flashed the firmware component from the interface and IP address due to a failure.

May also be shown as 4000002400000000 or 0x4000002400000000

Severity: Info

Alert Category: System - other

Serviceable: No

CIM Information: Prefix: IMM and ID: 0036

SNMP Trap ID: 22

Automatically notify Support: No

User response: Information only; no action is required.

40000025-00000000 The [arg1] on system [arg2] is 75% full.

Explanation: This message is for the use case where a Management Controller Event Log on a system is 75% full.

May also be shown as 4000002500000000 or 0x4000002500000000

Severity: Info

Alert Category: System - Event Log 75% full

Serviceable: No

CIM Information: Prefix: IMM and ID: 0037

SNMP Trap ID: 35

Automatically notify Support: No

User response: Information only; no action is required.

40000026-00000000 The [arg1] on system [arg2] is 100% full.

Explanation: This message is for the use case where a Management Controller Event Log on a system is 100% full.

May also be shown as 4000002600000000 or 0x4000002600000000

Severity: Info

Alert Category: System - Event Log 75% full

Serviceable: No

CIM Information: Prefix: IMM and ID: 0038

SNMP Trap ID: 35

Automatically notify Support: No

User response: To avoid losing older log entries, save the log as a text file and clear the log.

40000027-00000000 Platform Watchdog Timer expired for [arg1].

Explanation: This message is for the use case when an implementation has detected a Platform Watchdog Timer Expired

May also be shown as 4000002700000000 or 0x4000002700000000

Severity: Error

Alert Category: System - OS Timeout

Serviceable: No

CIM Information: Prefix: IMM and ID: 0039

SNMP Trap ID: 21

Automatically notify Support: No

User response: Complete the following steps until the problem is solved: Reconfigure the watchdog timer to a higher value. Make sure that the IMM Ethernet-over-USB interface is enabled. Reinstall the RNDIS or cdc_ether device driver for the operating system. Disable the watchdog. Check the integrity of the installed operating system.

40000028-00000000 Management Controller Test Alert Generated by [arg1].

Explanation: This message is for the use case where a client has generated a Test Alert.

May also be shown as 4000002800000000 or 0x4000002800000000

Severity: Info

Alert Category: System - other

Serviceable: No

CIM Information: Prefix: IMM and ID: 0040

SNMP Trap ID: 22

Automatically notify Support: No

User response: Information only; no action is required.

40000029-00000000 Security: Userid: [arg1] had [arg2] login failures from an SSH client at IP address [arg3].

Explanation: This message is for the use case where a client has failed to log in to a Management Controller from SSH.

May also be shown as 4000002900000000 or 0x4000002900000000

Severity: Info

Alert Category: System - Remote Login

Serviceable: No

CIM Information: Prefix: IMM and ID: 0041

SNMP Trap ID: 30

Automatically notify Support: No

User response: Complete the following steps until the problem is solved: Make sure that the correct login ID and password are being used. Have the system administrator reset the login ID or password.

4000002a-00000000 • 4000002c-00000000

4000002a-00000000 [arg1] firmware mismatch internal to system [arg2]. Please attempt to flash the [arg3] firmware.

Explanation: This message is for the use case where a specific type of firmware mismatch has been detected.

May also be shown as 4000002a00000000 or 0x4000002a00000000

Severity: Error

Alert Category: System - Other

Serviceable: No

CIM Information: Prefix: IMM and ID: 0042

SNMP Trap ID: 22

Automatically notify Support: No

User response: Reflash the IMM firmware to the latest version.

4000002b-00000000 Domain name set to [arg1].

Explanation: Domain name set by user

May also be shown as 4000002b00000000 or 0x4000002b00000000

Severity: Info

Alert Category: none

Serviceable: No

CIM Information: Prefix: IMM and ID: 0043

SNMP Trap ID:

Automatically notify Support: No

User response: Information only; no action is required.

4000002c-00000000 Domain Source changed to [arg1] by user [arg2].

Explanation: Domain source changed by user

May also be shown as 4000002c00000000 or 0x4000002c00000000

Severity: Info

Alert Category: none

Serviceable: No

CIM Information: Prefix: IMM and ID: 0044

SNMP Trap ID:

Automatically notify Support: No

User response: Information only; no action is required.

4000002d-00000000 DDNS setting changed to [arg1] by user [arg2].

Explanation: DDNS setting changed by user

May also be shown as 4000002d00000000 or 0x4000002d00000000

Severity: Info

Alert Category: none

Serviceable: No

CIM Information: Prefix: IMM and ID: 0045

SNMP Trap ID:

Automatically notify Support: No

User response: Information only; no action is required.

4000002e-00000000 DDNS registration successful. The domain name is [arg1].

Explanation: DDNS registration and values

May also be shown as 4000002e00000000 or 0x4000002e00000000

Severity: Info

Alert Category: none

Serviceable: No

CIM Information: Prefix: IMM and ID: 0046

SNMP Trap ID:

Automatically notify Support: No

User response: Information only; no action is required.

4000002f-00000000 IPv6 enabled by user [arg1] .

Explanation: IPv6 protocol is enabled by user

May also be shown as 4000002f00000000 or 0x4000002f00000000

Severity: Info

Alert Category: none

Serviceable: No

CIM Information: Prefix: IMM and ID: 0047

SNMP Trap ID:

Automatically notify Support: No

User response: Information only; no action is required.

40000030-00000000 • 40000032-00000000

40000030-00000000 IPv6 disabled by user [arg1] .

Explanation: IPv6 protocol is disabled by user

May also be shown as 4000003000000000 or 0x4000003000000000

Severity: Info

Alert Category: none

Serviceable: No

CIM Information: Prefix: IMM and ID: 0048

SNMP Trap ID:

Automatically notify Support: No

User response: Information only; no action is required.

40000031-00000000 IPv6 static IP configuration enabled by user [arg1].

Explanation: IPv6 static address assignment method is enabled by user

May also be shown as 4000003100000000 or 0x4000003100000000

Severity: Info

Alert Category: none

Serviceable: No

CIM Information: Prefix: IMM and ID: 0049

SNMP Trap ID:

Automatically notify Support: No

User response: Information only; no action is required.

40000032-00000000 IPv6 DHCP enabled by user [arg1].

Explanation: IPv6 DHCP assignment method is enabled by user

May also be shown as 4000003200000000 or 0x4000003200000000

Severity: Info

Alert Category: none

Serviceable: No

CIM Information: Prefix: IMM and ID: 0050

SNMP Trap ID:

Automatically notify Support: No

User response: Information only; no action is required.

40000033-00000000 IPv6 stateless auto-configuration enabled by user [arg1].

Explanation: IPv6 statless auto-assignment method is enabled by user

May also be shown as 4000003300000000 or 0x4000003300000000

Severity: Info

Alert Category: none

Serviceable: No

CIM Information: Prefix: IMM and ID: 0051

SNMP Trap ID:

Automatically notify Support: No

User response: Information only; no action is required.

40000034-00000000 IPv6 static IP configuration disabled by user [arg1].

Explanation: IPv6 static assignment method is disabled by user

May also be shown as 4000003400000000 or 0x4000003400000000

Severity: Info

Alert Category: none

Serviceable: No

CIM Information: Prefix: IMM and ID: 0052

SNMP Trap ID:

Automatically notify Support: No

User response: Information only; no action is required.

40000035-00000000 IPv6 DHCP disabled by user [arg1].

Explanation: IPv6 DHCP assignment method is disabled by user

May also be shown as 4000003500000000 or 0x4000003500000000

Severity: Info

Alert Category: none

Serviceable: No

CIM Information: Prefix: IMM and ID: 0053

SNMP Trap ID:

Automatically notify Support: No

User response: Information only; no action is required.

40000036-00000000 • 40000038-00000000

40000036-00000000 IPv6 stateless auto-configuration disabled by user [arg1].

Explanation: IPv6 statless auto-assignment method is disabled by user

May also be shown as 4000003600000000 or 0x4000003600000000

Severity: Info

Alert Category: none

Serviceable: No

CIM Information: Prefix: IMM and ID: 0054

SNMP Trap ID:

Automatically notify Support: No

User response: Information only; no action is required.

40000037-00000000 ENET[[arg1]] IPv6-LinkLocal:HstName=[arg2], IP@=[arg3] ,Pref=[arg4] .

Explanation: IPv6 Link Local address is active

May also be shown as 4000003700000000 or 0x4000003700000000

Severity: Info

Alert Category: none

Serviceable: No

CIM Information: Prefix: IMM and ID: 0055

SNMP Trap ID:

Automatically notify Support: No

User response: Information only; no action is required.

40000038-00000000 ENET[[arg1]] IPv6-Static:HstName=[arg2], IP@=[arg3] ,Pref=[arg4], GW@=[arg5] .

Explanation: IPv6 Static address is active

May also be shown as 4000003800000000 or 0x4000003800000000

Severity: Info

Alert Category: none

Serviceable: No

CIM Information: Prefix: IMM and ID: 0056

SNMP Trap ID:

Automatically notify Support: No

User response: Information only; no action is required.

40000039-00000000 ENET[[arg1]] DHCPv6-HSTN=[arg2], DN=[arg3], IP@[arg4], Pref=[arg5].

Explanation: IPv6 DHCP-assigned address is active

May also be shown as 4000003900000000 or 0x4000003900000000

Severity: Info

Alert Category: none

Serviceable: No

CIM Information: Prefix: IMM and ID: 0057

SNMP Trap ID:

Automatically notify Support: No

User response: Information only; no action is required.

4000003a-00000000 IPv6 static address of network interface modified from [arg1] to [arg2] by user [arg3].

Explanation: This message is for the use case where a client modifies the IPv6 static address of a Management Controller

May also be shown as 4000003a00000000 or 0x4000003a00000000

Severity: Info

Alert Category: none

Serviceable: No

CIM Information: Prefix: IMM and ID: 0058

SNMP Trap ID:

Automatically notify Support: No

User response: Information only; no action is required.

4000003b-00000000

Explanation: This message is for the use case where a DHCPv6 server fails to assign an IP address to a Management Controller.

May also be shown as 4000003b00000000 or 0x4000003b00000000

Severity: Warning

Alert Category: none

Serviceable: No

CIM Information: Prefix: IMM and ID: 0059

SNMP Trap ID:

Automatically notify Support: No

User response: Complete the following steps until the problem is solved: Make sure that the IMM network cable is connected. Make sure that there is a DHCPv6 server on the network that can assign an IP address to the IMM.

80010002-2801xxxx Numeric sensor [NumericSensorElementName] going low (lower non-critical) has asserted.
(CMOS Battery)

Explanation: This message is for the use case when an implementation has detected a Lower Non-critical sensor going low has asserted.

May also be shown as 800100022801xxxx or 0x800100022801xxxx

Severity: Warning

Alert Category: Warning - Voltage

Serviceable: Yes

CIM Information: Prefix: PLAT and ID: 0476

SNMP Trap ID: 13

Automatically notify Support: No

User response: Replace the system battery.

80010202-0701xxxx Numeric sensor [NumericSensorElementName] going low (lower critical) has asserted. (Planar 12V)

Explanation: This message is for the use case when an implementation has detected a Lower Critical sensor going low has asserted.

May also be shown as 800102020701xxxx or 0x800102020701xxxx

Severity: Error

Alert Category: Critical - Voltage

Serviceable: Yes

CIM Information: Prefix: PLAT and ID: 0480

SNMP Trap ID: 1

Automatically notify Support: Yes

User response: 1. Check power supply n LED. 2. Remove the failing power supply. 3. Follow actions for OVER SPEC LED in Light path diagnostics LEDs. 4. (Trained technician only) Replace the system board. (n = power supply number) Planar 3.3V : Planar 5V :

80010202-2801xxxx Numeric sensor [NumericSensorElementName] going low (lower critical) has asserted.
(CMOS Battery)

Explanation: This message is for the use case when an implementation has detected a Lower Critical sensor going low has asserted.

May also be shown as 800102022801xxxx or 0x800102022801xxxx

Severity: Error

Alert Category: Critical - Voltage

Serviceable: Yes

CIM Information: Prefix: PLAT and ID: 0480

SNMP Trap ID: 1

Automatically notify Support: Yes

User response: 1. Check power supply n LED. 2. Remove the failing power supply. 3. Follow actions for OVER SPEC LED in Light path diagnostics LEDs. 4. (Trained technician only) Replace the system board. (n = power supply number)

80010204-1d01xxxx Numeric sensor [NumericSensorElementName] going low (lower critical) has asserted. (Fan 1A Tach)

Explanation: This message is for the use case when an implementation has detected a Lower Critical sensor going low has asserted.

May also be shown as 800102041d01xxxx or 0x800102041d01xxxx

Severity: Error

Alert Category: Critical - Fan Failure

Serviceable: Yes

CIM Information: Prefix: PLAT and ID: 0480

SNMP Trap ID: 11

Automatically notify Support: No

User response: 1. Reseat the failing fan n, which is indicated by a lit LED near the fan connector on the system board. 2. Replace the failing fan. (n = fan number) Fan 1B Tach :

80010204-1d02xxxx Numeric sensor [NumericSensorElementName] going low (lower critical) has asserted. (Fan 2A Tach)

Explanation: This message is for the use case when an implementation has detected a Lower Critical sensor going low has asserted.

May also be shown as 800102041d02xxxx or 0x800102041d02xxxx

Severity: Error

Alert Category: Critical - Fan Failure

Serviceable: Yes

CIM Information: Prefix: PLAT and ID: 0480

SNMP Trap ID: 11

Automatically notify Support: No

User response: 1. Reseat the failing fan n, which is indicated by a lit LED near the fan connector on the system board. 2. Replace the failing fan. (n = fan number) Fan 2B Tach :

80010204-1d03xxxx Numeric sensor [NumericSensorElementName] going low (lower critical) has asserted. (Fan 3A Tach)

Explanation: This message is for the use case when an implementation has detected a Lower Critical sensor going low has asserted.

May also be shown as 800102041d03xxxx or 0x800102041d03xxxx

Severity: Error

Alert Category: Critical - Fan Failure

Serviceable: Yes

CIM Information: Prefix: PLAT and ID: 0480

SNMP Trap ID: 11

Automatically notify Support: No

User response: 1. Reseat the failing fan n, which is indicated by a lit LED near the fan connector on the system board. 2. Replace the failing fan. (n = fan number) Fan 3B Tach :

80010204-1d04xxxx • 80010204-1d06xxxx

80010204-1d04xxxx Numeric sensor [NumericSensorElementName] going low (lower critical) has asserted. (Fan 4A Tach)

Explanation: This message is for the use case when an implementation has detected a Lower Critical sensor going low has asserted.

May also be shown as 800102041d04xxxx or 0x800102041d04xxxx

Severity: Error

Alert Category: Critical - Fan Failure

Serviceable: Yes

CIM Information: Prefix: PLAT and ID: 0480

SNMP Trap ID: 11

Automatically notify Support: No

User response: 1. Reseat the failing fan n, which is indicated by a lit LED near the fan connector on the system board. 2. Replace the failing fan. (n = fan number) Fan 4B Tach :

80010204-1d05xxxx Numeric sensor [NumericSensorElementName] going low (lower critical) has asserted. (Fan 5A Tach)

Explanation: This message is for the use case when an implementation has detected a Lower Critical sensor going low has asserted.

May also be shown as 800102041d05xxxx or 0x800102041d05xxxx

Severity: Error

Alert Category: Critical - Fan Failure

Serviceable: Yes

CIM Information: Prefix: PLAT and ID: 0480

SNMP Trap ID: 11

Automatically notify Support: No

User response: 1. Reseat the failing fan n, which is indicated by a lit LED near the fan connector on the system board. 2. Replace the failing fan. (n = fan number) Fan 5B Tach :

80010204-1d06xxxx Numeric sensor [NumericSensorElementName] going low (lower critical) has asserted. (Fan 6A Tach)

Explanation: This message is for the use case when an implementation has detected a Lower Critical sensor going low has asserted.

May also be shown as 800102041d06xxxx or 0x800102041d06xxxx

Severity: Error

Alert Category: Critical - Fan Failure

Serviceable: Yes

CIM Information: Prefix: PLAT and ID: 0480

SNMP Trap ID: 11

Automatically notify Support: No

User response: 1. Reseat the failing fan n, which is indicated by a lit LED near the fan connector on the system board. 2. Replace the failing fan. (n = fan number) Fan 6B Tach :

**80010701-0c01xxxx Numeric sensor [NumericSensorElementName] going high (upper non-critical) has asserted.
(Ambient Temp)**

Explanation: This message is for the use case when an implementation has detected an Upper Non-critical sensor going high has asserted.

May also be shown as 800107010c01xxxx or 0x800107010c01xxxx

Severity: Warning

Alert Category: Warning - Temperature

Serviceable: Yes

CIM Information: Prefix: PLAT and ID: 0490

SNMP Trap ID: 12

Automatically notify Support: No

User response: 1. Reduce the temperature. 2. Check the server airflow. Make sure that nothing is blocking the air from coming into or preventing the air from exiting the server.

**80010901-0c01xxxx Numeric sensor [NumericSensorElementName] going high (upper critical) has asserted.
(Ambient Temp)**

Explanation: This message is for the use case when an implementation has detected an Upper Critical sensor going high has asserted.

May also be shown as 800109010c01xxxx or 0x800109010c01xxxx

Severity: Error

Alert Category: Critical - Temperature

Serviceable: Yes

CIM Information: Prefix: PLAT and ID: 0494

SNMP Trap ID: 0

Automatically notify Support: No

User response: 1. Reduce the ambient temperature. 2. Check the server airflow. Make sure that nothing is blocking the air from coming into or preventing the air from exiting the server.

**80010902-0701xxxx Numeric sensor [NumericSensorElementName] going high (upper critical) has asserted.
(Planar 12V)**

Explanation: This message is for the use case when an implementation has detected an Upper Critical sensor going high has asserted.

May also be shown as 800109020701xxxx or 0x800109020701xxxx

Severity: Error

Alert Category: Critical - Voltage

Serviceable: Yes

CIM Information: Prefix: PLAT and ID: 0494

SNMP Trap ID: 1

Automatically notify Support: Yes

User response: 1. Check power supply n LED. 2. Remove the failing power supply. 3. (Trained technician only) Replace the system board. (n = power supply number) Planar 3.3V : Planar 5V :

80010b01-0c01xxxx • 80070201-0301xxxx

80010b01-0c01xxxx Numeric sensor [NumericSensorElementName] going high (upper non-recoverable) has asserted. (Ambient Temp)

Explanation: This message is for the use case when an implementation has detected an Upper Non-recoverable sensor going high has asserted.

May also be shown as 80010b010c01xxxx or 0x80010b010c01xxxx

Severity: Error

Alert Category: Critical - Temperature

Serviceable: Yes

CIM Information: Prefix: PLAT and ID: 0498

SNMP Trap ID: 0

Automatically notify Support: No

User response: Check the server airflow. Make sure that nothing is blocking the air from coming into or preventing the air from exiting the server.

80030012-2301xxxx Sensor [SensorElementName] has deasserted. (OS RealTime Mod)

Explanation: This message is for the use case when an implementation has detected a Sensor has deasserted.

May also be shown as 800300122301xxxx or 0x800300122301xxxx

Severity: Info

Alert Category: System - Other

Serviceable: No

CIM Information: Prefix: PLAT and ID: 0509

SNMP Trap ID:

Automatically notify Support: No

User response: No action; information only.

80070201-0301xxxx Sensor [SensorElementName] has transitioned to critical from a less severe state. (CPU 1 OverTemp)

Explanation: This message is for the use case when an implementation has detected a Sensor transitioned to critical from less severe.

May also be shown as 800702010301xxxx or 0x800702010301xxxx

Severity: Error

Alert Category: Critical - Temperature

Serviceable: Yes

CIM Information: Prefix: PLAT and ID: 0522

SNMP Trap ID: 0

Automatically notify Support: No

User response: 1. Make sure that the fans are operating, that there are no obstructions to the airflow (front and rear of the server), that the air baffles are in place and correctly installed, and that the server cover is installed and completely closed. 2. Check the ambient temperature. You must be operating within the specifications (see Features and specifications for more information). 3. Make sure that the heat sink for microprocessor n is installed correctly. 4. (Trained technician only) Replace microprocessor n. (n = microprocessor number)

80070201-0302xxxx Sensor [SensorElementName] has transitioned to critical from a less severe state. (CPU 2 OverTemp)

Explanation: This message is for the use case when an implementation has detected a Sensor transitioned to critical from less severe.

May also be shown as 800702010302xxxx or 0x800702010302xxxx

Severity: Error

Alert Category: Critical - Temperature

Serviceable: Yes

CIM Information: Prefix: PLAT and **ID:** 0522

SNMP Trap ID: 0

Automatically notify Support: No

User response: 1. Make sure that the fans are operating, that there are no obstructions to the airflow (front and rear of the server), that the air baffles are in place and correctly installed, and that the server cover is installed and completely closed. 2. Check the ambient temperature. You must be operating within the specifications (see Features and specifications for more information). 3. Make sure that the heat sink for microprocessor n is installed correctly. 4. (Trained technician only) Replace microprocessor n. (n = microprocessor number)

80070201-2001xxxx Sensor [SensorElementName] has transitioned to critical from a less severe state. (DIMM 1 Temp)

Explanation: This message is for the use case when an implementation has detected a Sensor transitioned to critical from less severe.

May also be shown as 800702012001xxxx or 0x800702012001xxxx

Severity: Error

Alert Category: Critical - Temperature

Serviceable: Yes

CIM Information: Prefix: PLAT and **ID:** 0522

SNMP Trap ID: 0

Automatically notify Support: No

User response: 1. Make sure that the fans are operating, that there are no obstructions to the airflow (front and rear of the server), that the air baffles are in place and correctly installed, and that the server cover is installed and completely closed. 2. Check the ambient temperature. You must be operating within the specifications (see Features and specifications for more information). 3. Make sure that the heat sink for microprocessor n is installed correctly. 4. (Trained technician only) Replace microprocessor n. (n = microprocessor number)

80070201-2002xxxx Sensor [SensorElementName] has transitioned to critical from a less severe state. (DIMM 2 Temp)

Explanation: This message is for the use case when an implementation has detected a Sensor transitioned to critical from less severe.

May also be shown as 800702012002xxxx or 0x800702012002xxxx

Severity: Error

Alert Category: Critical - Temperature

Serviceable: Yes

CIM Information: Prefix: PLAT and ID: 0522

SNMP Trap ID: 0

Automatically notify Support: No

User response: 1. Make sure that the fans are operating, that there are no obstructions to the airflow (front and rear of the server), that the air baffles are in place and correctly installed, and that the server cover is installed and completely closed. 2. Check the ambient temperature. You must be operating within the specifications (see Features and specifications for more information). 3. Make sure that the heat sink for microprocessor n is installed correctly. 4. (Trained technician only) Replace microprocessor n. (n = microprocessor number)

80070201-2003xxxx Sensor [SensorElementName] has transitioned to critical from a less severe state. (DIMM 3 Temp)

Explanation: This message is for the use case when an implementation has detected a Sensor transitioned to critical from less severe.

May also be shown as 800702012003xxxx or 0x800702012003xxxx

Severity: Error

Alert Category: Critical - Temperature

Serviceable: Yes

CIM Information: Prefix: PLAT and ID: 0522

SNMP Trap ID: 0

Automatically notify Support: No

User response: 1. Make sure that the fans are operating, that there are no obstructions to the airflow (front and rear of the server), that the air baffles are in place and correctly installed, and that the server cover is installed and completely closed. 2. Check the ambient temperature. You must be operating within the specifications (see Features and specifications for more information). 3. Make sure that the heat sink for microprocessor n is installed correctly. 4. (Trained technician only) Replace microprocessor n. (n = microprocessor number)

80070201-2004xxxx Sensor [SensorElementName] has transitioned to critical from a less severe state. (DIMM 4 Temp)

Explanation: This message is for the use case when an implementation has detected a Sensor transitioned to critical from less severe.

May also be shown as 800702012004xxxx or 0x800702012004xxxx

Severity: Error

Alert Category: Critical - Temperature

Serviceable: Yes

CIM Information: Prefix: PLAT and **ID:** 0522

SNMP Trap ID: 0

Automatically notify Support: No

User response: 1. Make sure that the fans are operating, that there are no obstructions to the airflow (front and rear of the server), that the air baffles are in place and correctly installed, and that the server cover is installed and completely closed. 2. Check the ambient temperature. You must be operating within the specifications (see Features and specifications for more information). 3. Make sure that the heat sink for microprocessor n is installed correctly. 4. (Trained technician only) Replace microprocessor n. (n = microprocessor number)

80070201-2005xxxx Sensor [SensorElementName] has transitioned to critical from a less severe state. (DIMM 5 Temp)

Explanation: This message is for the use case when an implementation has detected a Sensor transitioned to critical from less severe.

May also be shown as 800702012005xxxx or 0x800702012005xxxx

Severity: Error

Alert Category: Critical - Temperature

Serviceable: Yes

CIM Information: Prefix: PLAT and **ID:** 0522

SNMP Trap ID: 0

Automatically notify Support: No

User response: 1. Make sure that the fans are operating, that there are no obstructions to the airflow (front and rear of the server), that the air baffles are in place and correctly installed, and that the server cover is installed and completely closed. 2. Check the ambient temperature. You must be operating within the specifications (see Features and specifications for more information). 3. Make sure that the heat sink for microprocessor n is installed correctly. 4. (Trained technician only) Replace microprocessor n. (n = microprocessor number)

80070201-2006xxxx Sensor [SensorElementName] has transitioned to critical from a less severe state. (DIMM 6 Temp)

Explanation: This message is for the use case when an implementation has detected a Sensor transitioned to critical from less severe.

May also be shown as 800702012006xxxx or 0x800702012006xxxx

Severity: Error

Alert Category: Critical - Temperature

Serviceable: Yes

CIM Information: Prefix: PLAT and **ID:** 0522

SNMP Trap ID: 0

Automatically notify Support: No

User response: 1. Make sure that the fans are operating, that there are no obstructions to the airflow (front and rear of the server), that the air baffles are in place and correctly installed, and that the server cover is installed and completely closed. 2. Check the ambient temperature. You must be operating within the specifications (see Features and specifications for more information). 3. Make sure that the heat sink for microprocessor n is installed correctly. 4. (Trained technician only) Replace microprocessor n. (n = microprocessor number)

80070201-2007xxxx Sensor [SensorElementName] has transitioned to critical from a less severe state. (DIMM 7 Temp)

Explanation: This message is for the use case when an implementation has detected a Sensor transitioned to critical from less severe.

May also be shown as 800702012007xxxx or 0x800702012007xxxx

Severity: Error

Alert Category: Critical - Temperature

Serviceable: Yes

CIM Information: Prefix: PLAT and **ID:** 0522

SNMP Trap ID: 0

Automatically notify Support: No

User response: 1. Make sure that the fans are operating, that there are no obstructions to the airflow (front and rear of the server), that the air baffles are in place and correctly installed, and that the server cover is installed and completely closed. 2. Check the ambient temperature. You must be operating within the specifications (see Features and specifications for more information). 3. Make sure that the heat sink for microprocessor n is installed correctly. 4. (Trained technician only) Replace microprocessor n. (n = microprocessor number)

80070201-2008xxxx Sensor [SensorElementName] has transitioned to critical from a less severe state. (DIMM 8 Temp)

Explanation: This message is for the use case when an implementation has detected a Sensor transitioned to critical from less severe.

May also be shown as 800702012008xxxx or 0x800702012008xxxx

Severity: Error

Alert Category: Critical - Temperature

Serviceable: Yes

CIM Information: Prefix: PLAT and **ID:** 0522

SNMP Trap ID: 0

Automatically notify Support: No

User response: 1. Make sure that the fans are operating, that there are no obstructions to the airflow (front and rear of the server), that the air baffles are in place and correctly installed, and that the server cover is installed and completely closed. 2. Check the ambient temperature. You must be operating within the specifications (see Features and specifications for more information). 3. Make sure that the heat sink for microprocessor n is installed correctly. 4. (Trained technician only) Replace microprocessor n. (n = microprocessor number)

80070201-2009xxxx Sensor [SensorElementName] has transitioned to critical from a less severe state. (DIMM 9 Temp)

Explanation: This message is for the use case when an implementation has detected a Sensor transitioned to critical from less severe.

May also be shown as 800702012009xxxx or 0x800702012009xxxx

Severity: Error

Alert Category: Critical - Temperature

Serviceable: Yes

CIM Information: Prefix: PLAT and **ID:** 0522

SNMP Trap ID: 0

Automatically notify Support: No

User response: 1. Make sure that the fans are operating, that there are no obstructions to the airflow (front and rear of the server), that the air baffles are in place and correctly installed, and that the server cover is installed and completely closed. 2. Check the ambient temperature. You must be operating within the specifications (see Features and specifications for more information). 3. Make sure that the heat sink for microprocessor n is installed correctly. 4. (Trained technician only) Replace microprocessor n. (n = microprocessor number)

80070201-200axxxx Sensor [SensorElementName] has transitioned to critical from a less severe state. (DIMM 10 Temp)

Explanation: This message is for the use case when an implementation has detected a Sensor transitioned to critical from less severe.

May also be shown as 80070201200axxxx or 0x80070201200axxxx

Severity: Error

Alert Category: Critical - Temperature

Serviceable: Yes

CIM Information: Prefix: PLAT and ID: 0522

SNMP Trap ID: 0

Automatically notify Support: No

User response: 1. Make sure that the fans are operating, that there are no obstructions to the airflow (front and rear of the server), that the air baffles are in place and correctly installed, and that the server cover is installed and completely closed. 2. Check the ambient temperature. You must be operating within the specifications (see Features and specifications for more information). 3. Make sure that the heat sink for microprocessor n is installed correctly. 4. (Trained technician only) Replace microprocessor n. (n = microprocessor number)

80070201-200bxxxx Sensor [SensorElementName] has transitioned to critical from a less severe state. (DIMM 11 Temp)

Explanation: This message is for the use case when an implementation has detected a Sensor transitioned to critical from less severe.

May also be shown as 80070201200bxxxx or 0x80070201200bxxxx

Severity: Error

Alert Category: Critical - Temperature

Serviceable: Yes

CIM Information: Prefix: PLAT and ID: 0522

SNMP Trap ID: 0

Automatically notify Support: No

User response: 1. Make sure that the fans are operating, that there are no obstructions to the airflow (front and rear of the server), that the air baffles are in place and correctly installed, and that the server cover is installed and completely closed. 2. Check the ambient temperature. You must be operating within the specifications (see Features and specifications for more information). 3. Make sure that the heat sink for microprocessor n is installed correctly. 4. (Trained technician only) Replace microprocessor n. (n = microprocessor number)

80070201-200cxxxx Sensor [SensorElementName] has transitioned to critical from a less severe state. (DIMM 12 Temp)

Explanation: This message is for the use case when an implementation has detected a Sensor transitioned to critical from less severe.

May also be shown as 80070201200cxxxx or 0x80070201200cxxxx

Severity: Error

Alert Category: Critical - Temperature

Serviceable: Yes

CIM Information: Prefix: PLAT and **ID:** 0522

SNMP Trap ID: 0

Automatically notify Support: No

User response: 1. Make sure that the fans are operating, that there are no obstructions to the airflow (front and rear of the server), that the air baffles are in place and correctly installed, and that the server cover is installed and completely closed. 2. Check the ambient temperature. You must be operating within the specifications (see Features and specifications for more information). 3. Make sure that the heat sink for microprocessor n is installed correctly. 4. (Trained technician only) Replace microprocessor n. (n = microprocessor number)

80070201-200dxxxx Sensor [SensorElementName] has transitioned to critical from a less severe state. (DIMM 13 Temp)

Explanation: This message is for the use case when an implementation has detected a Sensor transitioned to critical from less severe.

May also be shown as 80070201200dxxxx or 0x80070201200dxxxx

Severity: Error

Alert Category: Critical - Temperature

Serviceable: Yes

CIM Information: Prefix: PLAT and **ID:** 0522

SNMP Trap ID: 0

Automatically notify Support: No

User response: 1. Make sure that the fans are operating, that there are no obstructions to the airflow (front and rear of the server), that the air baffles are in place and correctly installed, and that the server cover is installed and completely closed. 2. Check the ambient temperature. You must be operating within the specifications (see Features and specifications for more information). 3. Make sure that the heat sink for microprocessor n is installed correctly. 4. (Trained technician only) Replace microprocessor n. (n = microprocessor number)

80070201-200exxxx Sensor [SensorElementName] has transitioned to critical from a less severe state. (DIMM 14 Temp)

Explanation: This message is for the use case when an implementation has detected a Sensor transitioned to critical from less severe.

May also be shown as 80070201200exxxx or 0x80070201200exxxx

Severity: Error

Alert Category: Critical - Temperature

Serviceable: Yes

CIM Information: Prefix: PLAT and **ID:** 0522

SNMP Trap ID: 0

Automatically notify Support: No

User response: 1. Make sure that the fans are operating, that there are no obstructions to the airflow (front and rear of the server), that the air baffles are in place and correctly installed, and that the server cover is installed and completely closed. 2. Check the ambient temperature. You must be operating within the specifications (see Features and specifications for more information). 3. Make sure that the heat sink for microprocessor n is installed correctly. 4. (Trained technician only) Replace microprocessor n. (n = microprocessor number)

80070201-200fxxxx Sensor [SensorElementName] has transitioned to critical from a less severe state. (DIMM 15 Temp)

Explanation: This message is for the use case when an implementation has detected a Sensor transitioned to critical from less severe.

May also be shown as 80070201200fxxxx or 0x80070201200fxxxx

Severity: Error

Alert Category: Critical - Temperature

Serviceable: Yes

CIM Information: Prefix: PLAT and **ID:** 0522

SNMP Trap ID: 0

Automatically notify Support: No

User response: 1. Make sure that the fans are operating, that there are no obstructions to the airflow (front and rear of the server), that the air baffles are in place and correctly installed, and that the server cover is installed and completely closed. 2. Check the ambient temperature. You must be operating within the specifications (see Features and specifications for more information). 3. Make sure that the heat sink for microprocessor n is installed correctly. 4. (Trained technician only) Replace microprocessor n. (n = microprocessor number)

80070201-2010xxxx Sensor [SensorElementName] has transitioned to critical from a less severe state. (DIMM 16 Temp)

Explanation: This message is for the use case when an implementation has detected a Sensor transitioned to critical from less severe.

May also be shown as 800702012010xxxx or 0x800702012010xxxx

Severity: Error

Alert Category: Critical - Temperature

Serviceable: Yes

CIM Information: Prefix: PLAT and **ID:** 0522

SNMP Trap ID: 0

Automatically notify Support: No

User response: 1. Make sure that the fans are operating, that there are no obstructions to the airflow (front and rear of the server), that the air baffles are in place and correctly installed, and that the server cover is installed and completely closed. 2. Check the ambient temperature. You must be operating within the specifications (see Features and specifications for more information). 3. Make sure that the heat sink for microprocessor n is installed correctly. 4. (Trained technician only) Replace microprocessor n. (n = microprocessor number)

80070201-2011xxxx Sensor [SensorElementName] has transitioned to critical from a less severe state. (DIMM 17 Temp)

Explanation: This message is for the use case when an implementation has detected a Sensor transitioned to critical from less severe.

May also be shown as 800702012011xxxx or 0x800702012011xxxx

Severity: Error

Alert Category: Critical - Temperature

Serviceable: Yes

CIM Information: Prefix: PLAT and **ID:** 0522

SNMP Trap ID: 0

Automatically notify Support: No

User response: 1. Make sure that the fans are operating, that there are no obstructions to the airflow (front and rear of the server), that the air baffles are in place and correctly installed, and that the server cover is installed and completely closed. 2. Check the ambient temperature. You must be operating within the specifications (see Features and specifications for more information). 3. Make sure that the heat sink for microprocessor n is installed correctly. 4. (Trained technician only) Replace microprocessor n. (n = microprocessor number)

80070201-2012xxxx Sensor [SensorElementName] has transitioned to critical from a less severe state. (DIMM 18 Temp)

Explanation: This message is for the use case when an implementation has detected a Sensor transitioned to critical from less severe.

May also be shown as 800702012012xxxx or 0x800702012012xxxx

Severity: Error

Alert Category: Critical - Temperature

Serviceable: Yes

CIM Information: **Prefix:** PLAT and **ID:** 0522

SNMP Trap ID: 0

Automatically notify Support: No

User response: 1. Make sure that the fans are operating, that there are no obstructions to the airflow (front and rear of the server), that the air baffles are in place and correctly installed, and that the server cover is installed and completely closed. 2. Check the ambient temperature. You must be operating within the specifications (see Features and specifications for more information). 3. Make sure that the heat sink for microprocessor n is installed correctly. 4. (Trained technician only) Replace microprocessor n. (n = microprocessor number)

80070201-2d01xxxx Sensor [SensorElementName] has transitioned to critical from a less severe state. (IOH Temp Status)

Explanation: This message is for the use case when an implementation has detected a Sensor transitioned to critical from less severe.

May also be shown as 800702012d01xxxx or 0x800702012d01xxxx

Severity: Error

Alert Category: Critical - Temperature

Serviceable: Yes

CIM Information: **Prefix:** PLAT and **ID:** 0522

SNMP Trap ID: 0

Automatically notify Support: No

User response: 1. Make sure that the fans are operating, that there are no obstructions to the airflow (front and rear of the server), that the air baffles are in place and correctly installed, and that the server cover is installed and completely closed. 2. Check the ambient temperature. You must be operating within the specifications (see Features and specifications for more information). 3. Make sure that the heat sink for microprocessor n is installed correctly. 4. (Trained technician only) Replace microprocessor n. (n = microprocessor number)

80070202-0701xxxx Sensor [SensorElementName] has transitioned to critical from a less severe state. (Planar Fault)

Explanation: This message is for the use case when an implementation has detected a Sensor transitioned to critical from less severe.

May also be shown as 800702020701xxxx or 0x800702020701xxxx

Severity: Error

Alert Category: Critical - Voltage

Serviceable: Yes

CIM Information: Prefix: PLAT and ID: 0522

SNMP Trap ID: 1

Automatically notify Support: No

User response: 1. Check the system-event log. 2. Check for an error LED on the system board. 3. Replace any failing device. 4. Check for a server firmware update. Important: Some cluster solutions require specific code levels or coordinated code updates. If the device is part of a cluster solution, verify that the latest level of code is supported for the cluster solution before you update the code. 5. (Trained technician only) Replace the system board.

80070204-0a01xxxx Sensor [SensorElementName] has transitioned to critical from a less severe state. (PS 1 Fan Fault)

Explanation: This message is for the use case when an implementation has detected a Sensor transitioned to critical from less severe.

May also be shown as 800702040a01xxxx or 0x800702040a01xxxx

Severity: Error

Alert Category: Critical - Fan Failure

Serviceable: Yes

CIM Information: Prefix: PLAT and ID: 0522

SNMP Trap ID: 11

Automatically notify Support: No

User response: 1. Make sure that there are no obstructions, such as bundled cables, to the airflow from the power-supply fan. 2. Replace power supply n. (n = power supply number)

80070204-0a02xxxx Sensor [SensorElementName] has transitioned to critical from a less severe state. (PS 2 Fan Fault)

Explanation: This message is for the use case when an implementation has detected a Sensor transitioned to critical from less severe.

May also be shown as 800702040a02xxxx or 0x800702040a02xxxx

Severity: Error

Alert Category: Critical - Fan Failure

Serviceable: Yes

CIM Information: Prefix: PLAT and ID: 0522

SNMP Trap ID: 11

Automatically notify Support: No

User response: 1. Make sure that there are no obstructions, such as bundled cables, to the airflow from the power-supply fan. 2. Replace power supply n. (n = power supply number)

80070208-0a01xxxx Sensor [SensorElementName] has transitioned to critical from a less severe state. (PS 1 OP Fault)

Explanation: This message is for the use case when an implementation has detected a Sensor transitioned to critical from less severe.

May also be shown as 800702080a01xxxx or 0x800702080a01xxxx

Severity: Error

Alert Category: Critical - Power

Serviceable: Yes

CIM Information: Prefix: PLAT and **ID:** 0522

SNMP Trap ID: 4

Automatically notify Support: No

User response: 1. Make sure that there are no obstructions, such as bundled cables, to the airflow from the power-supply fan. 2. Use the IBM Power Configurator utility to determine current system power consumption. For more information and to download the utility, go to <http://www-03.ibm.com/systems/bladecenter/resources/powerconfig.html>. 3. Replace power supply n. (n = power supply number) PS 1 Therm Fault :

80070208-0a02xxxx Sensor [SensorElementName] has transitioned to critical from a less severe state. (PS 2 OP Fault)

Explanation: This message is for the use case when an implementation has detected a Sensor transitioned to critical from less severe.

May also be shown as 800702080a02xxxx or 0x800702080a02xxxx

Severity: Error

Alert Category: Critical - Power

Serviceable: Yes

CIM Information: Prefix: PLAT and **ID:** 0522

SNMP Trap ID: 4

Automatically notify Support: No

User response: 1. Make sure that there are no obstructions, such as bundled cables, to the airflow from the power-supply fan. 2. Use the IBM Power Configurator utility to determine current system power consumption. For more information and to download the utility, go to <http://www-03.ibm.com/systems/bladecenter/resources/powerconfig.html>. 3. Replace power supply n. (n = power supply number) PS 2 Therm Fault :

8007020f-2582xxxx Sensor [SensorElementName] has transitioned to critical from a less severe state. (No I/O Resources)

Explanation: This message is for the use case when an implementation has detected a Sensor transitioned to critical from less severe.

May also be shown as 8007020f2582xxxx or 0x8007020f2582xxxx

Severity: Error

Alert Category: Critical - Other

Serviceable: Yes

CIM Information: Prefix: PLAT and **ID:** 0522

SNMP Trap ID: 50

Automatically notify Support: No

User response: Complete the following steps for PCI I/O resource error issue resolution: 1. Understand the I/O resource requirements in a basic system. 2. Identify the I/O resource requirements for desired add-in adapters. For

examples, PCI-X or PCIe adapters. 3. Disable on-board devices that you can do without and that request I/O. 4. In F1 setup, select the System Settings then Device and I/O Ports menu. 5. Remove adapters or disable slots until the I/O resource is less than 64 KB.

80070219-0701xxxx Sensor [SensorElementName] has transitioned to critical from a less severe state. (Sys Board Fault)

Explanation: This message is for the use case when an implementation has detected a Sensor transitioned to critical from less severe.

May also be shown as 800702190701xxxx or 0x800702190701xxxx

Severity: Error

Alert Category: Critical - Other

Serviceable: Yes

CIM Information: Prefix: PLAT and ID: 0522

SNMP Trap ID: 50

Automatically notify Support: No

User response: 1. Check the system-event log. 2. Check for an error LED on the system board. 3. Replace any failing device. 4. Check for a server firmware update. Important: Some cluster solutions require specific code levels or coordinated code updates. If the device is part of a cluster solution, verify that the latest level of code is supported for the cluster solution before you update the code. 5. (Trained technician only) Replace the system board.

80070301-0301xxxx Sensor [SensorElementName] has transitioned to non-recoverable from a less severe state. (CPU 1 OverTemp)

Explanation: This message is for the use case when an implementation has detected a Sensor transitioned to non-recoverable from less severe.

May also be shown as 800703010301xxxx or 0x800703010301xxxx

Severity: Error

Alert Category: Critical - Temperature

Serviceable: Yes

CIM Information: Prefix: PLAT and ID: 0524

SNMP Trap ID: 0

Automatically notify Support: No

User response: 1. Make sure that the fans are operating, that there are no obstructions to the airflow (front and rear of the server), that the air baffles are in place and correctly installed, and that the server cover is installed and completely closed. 2. Check the ambient temperature. You must be operating within the specifications (see Features and specifications for more information). 3. Make sure that the heat sink for microprocessor n. 4. (Trained technician only) Replace microprocessor n. (n = microprocessor number)

**80070301-0302xxxx Sensor [SensorElementName] has transitioned to non-recoverable from a less severe state.
(CPU 2 OverTemp)**

Explanation: This message is for the use case when an implementation has detected a Sensor transitioned to non-recoverable from less severe.

May also be shown as 800703010302xxxx or 0x800703010302xxxx

Severity: Error

Alert Category: Critical - Temperature

Serviceable: Yes

CIM Information: Prefix: PLAT and **ID:** 0524

SNMP Trap ID: 0

Automatically notify Support: No

User response: 1. Make sure that the fans are operating, that there are no obstructions to the airflow (front and rear of the server), that the air baffles are in place and correctly installed, and that the server cover is installed and completely closed. 2. Check the ambient temperature. You must be operating within the specifications (see Features and specifications for more information). 3. Make sure that the heat sink for microprocessor n. 4. (Trained technician only) Replace microprocessor n. (n = microprocessor number)

**80070301-2d01xxxx Sensor [SensorElementName] has transitioned to non-recoverable from a less severe state.
(IOH Temp Status)**

Explanation: This message is for the use case when an implementation has detected a Sensor transitioned to non-recoverable from less severe.

May also be shown as 800703012d01xxxx or 0x800703012d01xxxx

Severity: Error

Alert Category: Critical - Temperature

Serviceable: Yes

CIM Information: Prefix: PLAT and **ID:** 0524

SNMP Trap ID: 0

Automatically notify Support: No

User response: 1. Make sure that the fans are operating, that there are no obstructions to the airflow (front and rear of the server), that the air baffles are in place and correctly installed, and that the server cover is installed and completely closed. 2. Check the ambient temperature. You must be operating within the specifications (see Features and specifications for more information). 3. Make sure that the heat sink for microprocessor n. 4. (Trained technician only) Replace microprocessor n. (n = microprocessor number)

80070603-0701xxxx Sensor [SensorElementName] has transitioned to non-recoverable. (Pwr Rail A Fault)

Explanation: This message is for the use case when an implementation has detected a Sensor transitioned to non-recoverable.

May also be shown as 800706030701xxxx or 0x800706030701xxxx

Severity: Error

Alert Category: Critical - Power

Serviceable: Yes

CIM Information: Prefix: PLAT and ID: 0530

SNMP Trap ID: 4

Automatically notify Support: No

User response: 1. See Power problems for more information. 2. Turn off the server and disconnect it from power. 3. (Trained technician only) Replace the system board. 4. (Trained technician only) Replace the failing microprocessor.
Pwr Rail B Fault : Pwr Rail C Fault : Pwr Rail D Fault : Pwr Rail E Fault :

80070608-0701xxxx Sensor [SensorElementName] has transitioned to non-recoverable. (VT Fault)

Explanation: This message is for the use case when an implementation has detected a Sensor transitioned to non-recoverable.

May also be shown as 800706080701xxxx or 0x800706080701xxxx

Severity: Error

Alert Category: Critical - Power

Serviceable: Yes

CIM Information: Prefix: PLAT and ID: 0530

SNMP Trap ID: 4

Automatically notify Support: No

User response: 1. Check power supply n LED. 2. Replace power supply n. (n = power supply number)

80070608-0a01xxxx Sensor [SensorElementName] has transitioned to non-recoverable. (PS 1 VCO Fault)

Explanation: This message is for the use case when an implementation has detected a Sensor transitioned to non-recoverable.

May also be shown as 800706080a01xxxx or 0x800706080a01xxxx

Severity: Error

Alert Category: Critical - Power

Serviceable: Yes

CIM Information: Prefix: PLAT and ID: 0530

SNMP Trap ID: 4

Automatically notify Support: No

User response: 1. Check power supply n LED. 2. Replace power supply n. (n = power supply number) PS1 12V OC Fault : PS1 12V OV Fault : PS1 12V UV Fault :

80070608-0a02xxxx • 800b0108-1381xxxx

80070608-0a02xxxx Sensor [SensorElementName] has transitioned to non-recoverable. (PS 2 VCO Fault)

Explanation: This message is for the use case when an implementation has detected a Sensor transitioned to non-recoverable.

May also be shown as 800706080a02xxxx or 0x800706080a02xxxx

Severity: Error

Alert Category: Critical - Power

Serviceable: Yes

CIM Information: Prefix: PLAT and ID: 0530

SNMP Trap ID: 4

Automatically notify Support: No

User response: 1. Check power supply n LED. 2. Replace power supply n. (n = power supply number) PS2 12V OC Fault : PS2 12V OV Fault : PS2 12V UV Fault :

800b0008-1381xxxx Redundancy [RedundancySetElementName] has been restored. (Power Unit)

Explanation: This message is for the use case when an implementation has detected Redundancy was Restored.

May also be shown as 800b00081381xxxx or 0x800b00081381xxxx

Severity: Info

Alert Category: Warning - Redundant Power Supply

Serviceable: No

CIM Information: Prefix: PLAT and ID: 0561

SNMP Trap ID: 10

Automatically notify Support: No

User response: No action; information only.

800b0108-1381xxxx Redundancy Lost for [RedundancySetElementName] has asserted. (Power Unit)

Explanation: This message is for the use case when Redundancy Lost has asserted.

May also be shown as 800b01081381xxxx or 0x800b01081381xxxx

Severity: Error

Alert Category: Critical - Redundant Power Supply

Serviceable: Yes

CIM Information: Prefix: PLAT and ID: 0802

SNMP Trap ID: 9

Automatically notify Support: No

User response: 1. Check the LEDs for both power supplies. 2. Follow the actions in Power-supply LEDs.

800b010a-1e81xxxx Redundancy Lost for [RedundancySetElementName] has asserted. (Cooling Zone 1)

Explanation: This message is for the use case when Redundancy Lost has asserted.

May also be shown as 800b010a1e81xxxx or 0x800b010a1e81xxxx

Severity: Error

Alert Category: Critical - Fan Failure

Serviceable: Yes

CIM Information: Prefix: PLAT and ID: 0802

SNMP Trap ID: 11

Automatically notify Support: No

User response: 1. Make sure that the connectors on fan n are not damaged. 2. Make sure that the fan n connectors on the system board are not damaged. 3. Make sure that the fans are correctly installed. 4. Reseat the fans. 5. Replace the fans. (n = fan number)

800b010a-1e82xxxx Redundancy Lost for [RedundancySetElementName] has asserted. (Cooling Zone 2)

Explanation: This message is for the use case when Redundancy Lost has asserted.

May also be shown as 800b010a1e82xxxx or 0x800b010a1e82xxxx

Severity: Error

Alert Category: Critical - Fan Failure

Serviceable: Yes

CIM Information: Prefix: PLAT and ID: 0802

SNMP Trap ID: 11

Automatically notify Support: No

User response: 1. Make sure that the connectors on fan n are not damaged. 2. Make sure that the fan n connectors on the system board are not damaged. 3. Make sure that the fans are correctly installed. 4. Reseat the fans. 5. Replace the fans. (n = fan number)

800b010a-1e83xxxx Redundancy Lost for [RedundancySetElementName] has asserted. (Cooling Zone 3)

Explanation: This message is for the use case when Redundancy Lost has asserted.

May also be shown as 800b010a1e83xxxx or 0x800b010a1e83xxxx

Severity: Error

Alert Category: Critical - Fan Failure

Serviceable: Yes

CIM Information: Prefix: PLAT and ID: 0802

SNMP Trap ID: 11

Automatically notify Support: No

User response: 1. Make sure that the connectors on fan n are not damaged. 2. Make sure that the fan n connectors on the system board are not damaged. 3. Make sure that the fans are correctly installed. 4. Reseat the fans. 5. Replace the fans. (n = fan number)

800b010c-2581xxxx Redundancy Lost for [RedundancySetElementName] has asserted. (Backup Memory)

Explanation: This message is for the use case when Redundancy Lost has asserted.

May also be shown as 800b010c2581xxxx or 0x800b010c2581xxxx

Severity: Error

Alert Category: Critical - Memory

Serviceable: Yes

CIM Information: Prefix: PLAT and ID: 0802

SNMP Trap ID: 41

Automatically notify Support: No

User response: 1. Check the system-event log for DIMM failure events (uncorrectable or PFA) and correct the failures. 2. Re-enable mirroring in the Setup utility.

800b030c-2581xxxx Non-redundant:Sufficient Resources from Redundancy Degraded or Fully Redundant for [RedundancySetElementName] has asserted. (Backup Memory)

Explanation: This message is for the use case when a Redundancy Set has transitioned from Redundancy Degraded or Fully Redundant to Non-redundant:Sufficient.

May also be shown as 800b030c2581xxxx or 0x800b030c2581xxxx

Severity: Warning

Alert Category: Warning - Memory

Serviceable: Yes

CIM Information: Prefix: PLAT and ID: 0806

SNMP Trap ID: 43

Automatically notify Support: No

User response: 1. Check the system-event log for DIMM failure events (uncorrectable or PFA) and correct the failures. 2. Re-enable mirroring in the Setup utility.

800b050a-1e81xxxx Non-redundant:Insufficient Resources for [RedundancySetElementName] has asserted. (Cooling Zone 1)

Explanation: This message is for the use case when a Redundancy Set has transitioned to Non-redundant:Insufficient Resources.

May also be shown as 800b050a1e81xxxx or 0x800b050a1e81xxxx

Severity: Error

Alert Category: Critical - Fan Failure

Serviceable: Yes

CIM Information: Prefix: PLAT and ID: 0810

SNMP Trap ID: 11

Automatically notify Support: No

User response: 1. Make sure that the connectors on fan n are not damaged. 2. Make sure that the fan n connectors on the system board are not damaged. 3. Make sure that the fans are correctly installed. 4. Reseat the fans. 5. Replace the fans. (n = fan number)

**800b050a-1e82xxxx Non-redundant:Insufficient Resources for [RedundancySetElementName] has asserted.
(Cooling Zone 2)**

Explanation: This message is for the use case when a Redundancy Set has transitioned to Non-redundant:Insufficient Resources.

May also be shown as 800b050a1e82xxxx or 0x800b050a1e82xxxx

Severity: Error

Alert Category: Critical - Fan Failure

Serviceable: Yes

CIM Information: Prefix: PLAT and ID: 0810

SNMP Trap ID: 11

Automatically notify Support: No

User response: 1. Make sure that the connectors on fan n are not damaged. 2. Make sure that the fan n connectors on the system board are not damaged. 3. Make sure that the fans are correctly installed. 4. Reseat the fans. 5. Replace the fans. (n = fan number)

**800b050a-1e83xxxx Non-redundant:Insufficient Resources for [RedundancySetElementName] has asserted.
(Cooling Zone 3)**

Explanation: This message is for the use case when a Redundancy Set has transitioned to Non-redundant:Insufficient Resources.

May also be shown as 800b050a1e83xxxx or 0x800b050a1e83xxxx

Severity: Error

Alert Category: Critical - Fan Failure

Serviceable: Yes

CIM Information: Prefix: PLAT and ID: 0810

SNMP Trap ID: 11

Automatically notify Support: No

User response: 1. Make sure that the connectors on fan n are not damaged. 2. Make sure that the fan n connectors on the system board are not damaged. 3. Make sure that the fans are correctly installed. 4. Reseat the fans. 5. Replace the fans. (n = fan number)

**800b050c-2581xxxx Non-redundant:Insufficient Resources for [RedundancySetElementName] has asserted.
(Backup Memory)**

Explanation: This message is for the use case when a Redundancy Set has transitioned to Non-redundant:Insufficient Resources.

May also be shown as 800b050c2581xxxx or 0x800b050c2581xxxx

Severity: Error

Alert Category: Critical - Memory

Serviceable: Yes

CIM Information: Prefix: PLAT and ID: 0810

SNMP Trap ID: 41

Automatically notify Support: No

User response: 1. Check the system-event log for DIMM failure events (uncorrectable or PFA) and correct the failures. 2. Re-enable mirroring in the Setup utility.

806f0007-0301xxxx [ProcessorElementName] has Failed with IERR. (CPU 1)

Explanation: This message is for the use case when an implementation has detected a Processor Failed - IERR Condition.

May also be shown as 806f00070301xxxx or 0x806f00070301xxxx

Severity: Error

Alert Category: Critical - CPU

Serviceable: Yes

CIM Information: Prefix: PLAT and ID: 0042

SNMP Trap ID: 40

Automatically notify Support: No

User response: 1. Make sure that the latest levels of firmware and device drivers are installed for all adapters and standard devices, such as Ethernet, SCSI, and SAS. Important: Some cluster solutions require specific code levels or coordinated code updates. If the device is part of a cluster solution, verify that the latest level of code is supported for the cluster solution before you update the code. 2. Update the firmware (UEFI and IMM) to the latest level (Updating the firmware). 3. Run the DSA program. 4. Reseat the adapter. 5. Replace the adapter. 6. (Trained technician only) Replace microprocessor n. 7. (Trained technician only) Replace the system board. (n = microprocessor number)

806f0007-0302xxxx [ProcessorElementName] has Failed with IERR. (CPU 2)

Explanation: This message is for the use case when an implementation has detected a Processor Failed - IERR Condition.

May also be shown as 806f00070302xxxx or 0x806f00070302xxxx

Severity: Error

Alert Category: Critical - CPU

Serviceable: Yes

CIM Information: Prefix: PLAT and ID: 0042

SNMP Trap ID: 40

Automatically notify Support: No

User response: 1. Make sure that the latest levels of firmware and device drivers are installed for all adapters and standard devices, such as Ethernet, SCSI, and SAS. Important: Some cluster solutions require specific code levels or coordinated code updates. If the device is part of a cluster solution, verify that the latest level of code is supported for the cluster solution before you update the code. 2. Update the firmware (UEFI and IMM) to the latest level (Updating the firmware). 3. Run the DSA program. 4. Reseat the adapter. 5. Replace the adapter. 6. (Trained technician only) Replace microprocessor n. 7. (Trained technician only) Replace the system board. (n = microprocessor number)

806f0008-0a01xxxx [PowerSupplyElementName] has been added to container [PhysicalPackageElementName].
(Power Supply 1)

Explanation: This message is for the use case when an implementation has detected a Power Supply has been added.

May also be shown as 806f00080a01xxxx or 0x806f00080a01xxxx

Severity: Info

Alert Category: System - Other

Serviceable: No

CIM Information: Prefix: PLAT and ID: 0084

SNMP Trap ID:

Automatically notify Support: No

User response: No action; information only.

806f0008-0a02xxxx [PowerSupplyElementName] has been added to container [PhysicalPackageElementName].
(Power Supply 2)

Explanation: This message is for the use case when an implementation has detected a Power Supply has been added.

May also be shown as 806f00080a02xxxx or 0x806f00080a02xxxx

Severity: Info

Alert Category: System - Other

Serviceable: No

CIM Information: Prefix: PLAT and ID: 0084

SNMP Trap ID:

Automatically notify Support: No

User response: No action; information only.

806f0009-1381xxxx [PowerSupplyElementName] has been turned off. (Host Power)

Explanation: This message is for the use case when an implementation has detected a Power Unit that has been Disabled.

May also be shown as 806f00091381xxxx or 0x806f00091381xxxx

Severity: Info

Alert Category: System - Power Off

Serviceable: No

CIM Information: Prefix: PLAT and ID: 0106

SNMP Trap ID: 23

Automatically notify Support: No

User response: No action; information only.

806f000d-0400xxxx The Drive [StorageVolumeElementName] has been added. (Drive 0)

Explanation: This message is for the use case when an implementation has detected a Drive has been Added.

May also be shown as 806f000d0400xxxx or 0x806f000d0400xxxx

Severity: Info

Alert Category: Critical - Hard Disk drive

Serviceable: No

CIM Information: Prefix: PLAT and ID: 0162

SNMP Trap ID: 5

Automatically notify Support: No

User response: No action; information only.

806f000d-0401xxxx The Drive [StorageVolumeElementName] has been added. (Drive 1)

Explanation: This message is for the use case when an implementation has detected a Drive has been Added.

May also be shown as 806f000d0401xxxx or 0x806f000d0401xxxx

Severity: Info

Alert Category: Critical - Hard Disk drive

Serviceable: No

CIM Information: Prefix: PLAT and ID: 0162

SNMP Trap ID: 5

Automatically notify Support: No

User response: No action; information only.

806f000d-0402xxxx The Drive [StorageVolumeElementName] has been added. (Drive 2)

Explanation: This message is for the use case when an implementation has detected a Drive has been Added.

May also be shown as 806f000d0402xxxx or 0x806f000d0402xxxx

Severity: Info

Alert Category: Critical - Hard Disk drive

Serviceable: No

CIM Information: Prefix: PLAT and ID: 0162

SNMP Trap ID: 5

Automatically notify Support: No

User response: No action; information only.

806f000d-0403xxxx The Drive [StorageVolumeElementName] has been added. (Drive 3)

Explanation: This message is for the use case when an implementation has detected a Drive has been Added.

May also be shown as 806f000d0403xxxx or 0x806f000d0403xxxx

Severity: Info

Alert Category: Critical - Hard Disk drive

Serviceable: No

CIM Information: Prefix: PLAT and ID: 0162

SNMP Trap ID: 5

Automatically notify Support: No

User response: No action; information only.

806f000d-0404xxxx The Drive [StorageVolumeElementName] has been added. (Drive 4)

Explanation: This message is for the use case when an implementation has detected a Drive has been Added.

May also be shown as 806f000d0404xxxx or 0x806f000d0404xxxx

Severity: Info

Alert Category: Critical - Hard Disk drive

Serviceable: No

CIM Information: Prefix: PLAT and ID: 0162

SNMP Trap ID: 5

Automatically notify Support: No

User response: No action; information only.

806f000d-0405xxxx The Drive [StorageVolumeElementName] has been added. (Drive 5)

Explanation: This message is for the use case when an implementation has detected a Drive has been Added.

May also be shown as 806f000d0405xxxx or 0x806f000d0405xxxx

Severity: Info

Alert Category: Critical - Hard Disk drive

Serviceable: No

CIM Information: Prefix: PLAT and ID: 0162

SNMP Trap ID: 5

Automatically notify Support: No

User response: No action; information only.

806f000d-0406xxxx The Drive [StorageVolumeElementName] has been added. (Drive 6)

Explanation: This message is for the use case when an implementation has detected a Drive has been Added.

May also be shown as 806f000d0406xxxx or 0x806f000d0406xxxx

Severity: Info

Alert Category: Critical - Hard Disk drive

Serviceable: No

CIM Information: Prefix: PLAT and ID: 0162

SNMP Trap ID: 5

Automatically notify Support: No

User response: No action; information only.

806f000d-0407xxxx The Drive [StorageVolumeElementName] has been added. (Drive 7)

Explanation: This message is for the use case when an implementation has detected a Drive has been Added.

May also be shown as 806f000d0407xxxx or 0x806f000d0407xxxx

Severity: Info

Alert Category: Critical - Hard Disk drive

Serviceable: No

CIM Information: Prefix: PLAT and ID: 0162

SNMP Trap ID: 5

Automatically notify Support: No

User response: No action; information only.

806f000f-220101xx The System [ComputerSystemElementName] has detected no memory in the system. (ABR Status)

Explanation: This message is for the use case when an implementation has detected that memory was detected in the system.

May also be shown as 806f000f220101xx or 0x806f000f220101xx

Severity: Error

Alert Category: Critical - Memory

Serviceable: Yes

CIM Information: Prefix: PLAT and ID: 0794

SNMP Trap ID: 41

Automatically notify Support: No

User response: 1. Make sure the server meets the minimum configuration to start (see Power-supply LEDs). 2. Recover the server firmware from the backup page: a. Restart the server. b. At the prompt, press F3 to recover the firmware. 3. Update the server firmware on the primary page. Important: Some cluster solutions require specific code levels or coordinated code updates. If the device is part of a cluster solution, verify that the latest level of code is supported for the cluster solution before you update the code. 4. Remove components one at a time, restarting the server each time, to see if the problem goes away. 5. If the problem remains, (Trained technician only) replace the system board. Firmware Error :

806f000f-220102xx Subsystem [MemoryElementName] has insufficient memory for operation. (ABR Status)

Explanation: This message is for the use case when an implementation has detected that the usable Memory is insufficient for operation.

May also be shown as 806f000f220102xx or 0x806f000f220102xx

Severity: Error

Alert Category: Critical - Memory

Serviceable: Yes

CIM Information: Prefix: PLAT and ID: 0132

SNMP Trap ID: 41

Automatically notify Support: No

User response: 1. Make sure the server meets the minimum configuration to start (see Power-supply LEDs). 2. Update the server firmware on the primary page. Important: Some cluster solutions require specific code levels or coordinated code updates. If the device is part of a cluster solution, verify that the latest level of code is supported for the cluster solution before you update the code. 3. (Trained technician only) Replace the system board. Firmware Error :

806f000f-220103xx The System [ComputerSystemElementName] encountered firmware error - unrecoverable boot device failure. (ABR Status)

Explanation: This message is for the use case when an implementation has detected that System Firmware Error Unrecoverable boot device failure has occurred.

May also be shown as 806f000f220103xx or 0x806f000f220103xx

Severity: Error

Alert Category: Critical - Hard Disk drive

Serviceable: Yes

CIM Information: Prefix: PLAT and ID: 0770

SNMP Trap ID: 5

Automatically notify Support: No

User response: This is a UEFI detected event. The UEFI diagnostic code for this event can be found in the logged IMM message text. Please refer to the UEFI diagnostic code in the "UEFI diagnostic code" section of the Info Center for the appropriate user response. Firmware Error :

806f000f-220104xx The System [ComputerSystemElementName] has encountered a motherboard failure. (ABR Status)

Explanation: This message is for the use case when an implementation has detected that a fatal motherboard failure in the system.

May also be shown as 806f000f220104xx or 0x806f000f220104xx

Severity: Error

Alert Category: Critical - Other

Serviceable: Yes

CIM Information: Prefix: PLAT and ID: 0795

SNMP Trap ID: 50

Automatically notify Support: No

User response: This is a UEFI detected event. The UEFI diagnostic code for this event can be found in the logged IMM message text. Please refer to the UEFI diagnostic code in the "UEFI diagnostic code" section of the Info Center for the appropriate user response. Firmware Error :

806f000f-220107xx • 806f000f-22010bxx

806f000f-220107xx The System [ComputerSystemElementName] encountered firmware error - unrecoverable keyboard failure. (ABR Status)

Explanation: This message is for the use case when an implementation has detected that System Firmware Error Unrecoverable Keyboard failure has occurred.

May also be shown as 806f000f220107xx or 0x806f000f220107xx

Severity: Error

Alert Category: Critical - Other

Serviceable: Yes

CIM Information: Prefix: PLAT and ID: 0764

SNMP Trap ID: 50

Automatically notify Support: No

User response: This is a UEFI detected event. The UEFI diagnostic code for this event can be found in the logged IMM message text. Please refer to the UEFI diagnostic code in the "UEFI diagnostic code" section of the Info Center for the appropriate user response. Firmware Error :

806f000f-22010axx The System [ComputerSystemElementName] encountered firmware error - no video device detected. (ABR Status)

Explanation: This message is for the use case when an implementation has detected that System Firmware Error No video device detected has occurred.

May also be shown as 806f000f22010axx or 0x806f000f22010axx

Severity: Error

Alert Category: Critical - Other

Serviceable: Yes

CIM Information: Prefix: PLAT and ID: 0766

SNMP Trap ID: 50

Automatically notify Support: No

User response: This is a UEFI detected event. The UEFI diagnostic code for this event can be found in the logged IMM message text. Please refer to the UEFI diagnostic code in the "UEFI diagnostic code" section of the Info Center for the appropriate user response. Firmware Error :

806f000f-22010bxx Firmware BIOS (ROM) corruption was detected on system [ComputerSystemElementName] during POST. (ABR Status)

Explanation: Firmware BIOS (ROM) corruption was detected on the system during POST.

May also be shown as 806f000f22010bxx or 0x806f000f22010bxx

Severity: Info

Alert Category: Critical - Other

Serviceable: Yes

CIM Information: Prefix: PLAT and ID: 0850

SNMP Trap ID: 40

Automatically notify Support: No

User response: 1. Make sure the server meets the minimum configuration to start (see Power-supply LEDs). 2. Recover the server firmware from the backup page: a. Restart the server. b. At the prompt, press F3 to recover the firmware. 3. Update the server firmware to the latest level (see Updating the firmware). Important: Some cluster solutions require specific code levels or coordinated code updates. If the device is part of a cluster solution, verify that the latest level of code is supported for the cluster solution before you update the code. 4. Remove components

one at a time, restarting the server each time, to see if the problem goes away. 5. If the problem remains, (trained service technician) replace the system board. Firmware Error :

806f000f-22010cxx CPU voltage mismatch detected on [ProcessorElementName]. (ABR Status)

Explanation: This message is for the use case when an implementation has detected a CPU voltage mismatch with the socket voltage.

May also be shown as 806f000f22010cxx or 0x806f000f22010cxx

Severity: Error

Alert Category: Critical - CPU

Serviceable: Yes

CIM Information: Prefix: PLAT and ID: 0050

SNMP Trap ID: 40

Automatically notify Support: No

User response: This is a UEFI detected event. The UEFI diagnostic code for this event can be found in the logged IMM message text. Please refer to the UEFI diagnostic code in the "UEFI diagnostic code" section of the Info Center for the appropriate user response. Firmware Error :

806f000f-2201ffff The System [ComputerSystemElementName] encountered a POST Error. (ABR Status)

Explanation: This message is for the use case when an implementation has detected a Post Error.

May also be shown as 806f000f2201ffff or 0x806f000f2201ffff

Severity: Error

Alert Category: Critical - Other

Serviceable: Yes

CIM Information: Prefix: PLAT and ID: 0184

SNMP Trap ID: 50

Automatically notify Support: No

User response: This is a UEFI detected event. The UEFI diagnostic code for this event can be found in the logged IMM message text. Please refer to the UEFI diagnostic code in the "UEFI diagnostic code" section of the Info Center for the appropriate user response. Firmware Error :

806f0013-1701xxxx A diagnostic interrupt has occurred on system [ComputerSystemElementName]. (NMI State)

Explanation: This message is for the use case when an implementation has detected a Front Panel NMI / Diagnostic Interrupt.

May also be shown as 806f00131701xxxx or 0x806f00131701xxxx

Severity: Error

Alert Category: Critical - Other

Serviceable: Yes

CIM Information: Prefix: PLAT and ID: 0222

SNMP Trap ID: 50

Automatically notify Support: No

User response: If the NMI button has not been pressed, complete the following steps: 1. Make sure that the NMI button is not pressed. 2. Replace the operator information panel cable. 3. Replace the operator information panel.

**806f0021-2201xxxx Fault in slot [PhysicalConnectorSystemElementName] on system
[ComputerSystemElementName]. (No Op ROM Space)**

Explanation: This message is for the use case when an implementation has detected a Fault in a slot.

May also be shown as 806f00212201xxxx or 0x806f00212201xxxx

Severity: Error

Alert Category: Critical - Other

Serviceable: Yes

CIM Information: Prefix: PLAT and ID: 0330

SNMP Trap ID: 50

Automatically notify Support: Yes

User response: 1. Check the PCI LED. 2. Reseat the affected adapters and riser card. 3. Update the server firmware (UEFI and IMM) and adapter firmware. Important: Some cluster solutions require specific code levels or coordinated code updates. If the device is part of a cluster solution, verify that the latest level of code is supported for the cluster solution before you update the code. 4. Remove both adapters. 5. Replace the riser cards. 6. (Trained service technicians only) Replace the system board.

**806f0021-2582xxxx Fault in slot [PhysicalConnectorSystemElementName] on system
[ComputerSystemElementName]. (All PCI Error)**

Explanation: This message is for the use case when an implementation has detected a Fault in a slot.

May also be shown as 806f00212582xxxx or 0x806f00212582xxxx

Severity: Error

Alert Category: Critical - Other

Serviceable: Yes

CIM Information: Prefix: PLAT and ID: 0330

SNMP Trap ID: 50

Automatically notify Support: Yes

User response: 1. Check the PCI LED. 2. Reseat the affected adapters and riser card. 3. Update the server firmware (UEFI and IMM) and adapter firmware. Important: Some cluster solutions require specific code levels or coordinated code updates. If the device is part of a cluster solution, verify that the latest level of code is supported for the cluster solution before you update the code. 4. Remove both adapters. 5. Replace the riser cards. 6. (Trained service technicians only) Replace the system board. One of PCI Error :

**806f0021-3001xxxx Fault in slot [PhysicalConnectorSystemElementName] on system
[ComputerSystemElementName]. (PCI 1)**

Explanation: This message is for the use case when an implementation has detected a Fault in a slot.

May also be shown as 806f00213001xxxx or 0x806f00213001xxxx

Severity: Error

Alert Category: Critical - Other

Serviceable: Yes

CIM Information: Prefix: PLAT and ID: 0330

SNMP Trap ID: 50

Automatically notify Support: Yes

User response: 1. Check the PCI LED. 2. Reseat the affected adapters and riser card. 3. Update the server firmware (UEFI and IMM) and adapter firmware. Important: Some cluster solutions require specific code levels or coordinated code updates. If the device is part of a cluster solution, verify that the latest level of code is supported for the cluster

solution before you update the code. 4. Remove both adapters. 5. Replace the riser cards. 6. (Trained service technicians only) Replace the system board. PCI 2 : PCI 5 :

806f0023-2101xxxx Watchdog Timer expired for [WatchdogElementName]. (Watchdog)

Explanation: This message is for the use case when an implementation has detected a Watchdog Timer Expired.

May also be shown as 806f00232101xxxx or 0x806f00232101xxxx

Severity: Info

Alert Category: System - Other

Serviceable: No

CIM Information: Prefix: PLAT and ID: 0368

SNMP Trap ID:

Automatically notify Support: No

User response: No action; information only.

806f0107-0301xxxx An Over-Temperature Condition has been detected on [ProcessorElementName]. (CPU 1)

Explanation: This message is for the use case when an implementation has detected an Over-Temperature Condition Detected for Processor.

May also be shown as 806f01070301xxxx or 0x806f01070301xxxx

Severity: Error

Alert Category: Critical - Temperature

Serviceable: Yes

CIM Information: Prefix: PLAT and ID: 0036

SNMP Trap ID: 0

Automatically notify Support: No

User response: 1. Make sure that the fans are operating. There are no obstructions to the airflow (front and rear of the server), the air baffles are in place and correctly installed, and the server cover is installed and completely closed. 2. Make sure that the heat sink for microprocessor n is installed correctly. 3. (Trained technician only) Replace microprocessor n. (n = microprocessor number)

806f0107-0302xxxx An Over-Temperature Condition has been detected on [ProcessorElementName]. (CPU 2)

Explanation: This message is for the use case when an implementation has detected an Over-Temperature Condition Detected for Processor.

May also be shown as 806f01070302xxxx or 0x806f01070302xxxx

Severity: Error

Alert Category: Critical - Temperature

Serviceable: Yes

CIM Information: Prefix: PLAT and ID: 0036

SNMP Trap ID: 0

Automatically notify Support: No

User response: 1. Make sure that the fans are operating. There are no obstructions to the airflow (front and rear of the server), the air baffles are in place and correctly installed, and the server cover is installed and completely closed. 2. Make sure that the heat sink for microprocessor n is installed correctly. 3. (Trained technician only) Replace microprocessor n. (n = microprocessor number)

806f0108-0a01xxxx [PowerSupplyElementName] has Failed. (Power Supply 1)

Explanation: This message is for the use case when an implementation has detected a Power Supply has failed.

May also be shown as 806f01080a01xxxx or 0x806f01080a01xxxx

Severity: Error

Alert Category: Critical - Power

Serviceable: Yes

CIM Information: Prefix: PLAT and ID: 0086

SNMP Trap ID: 4

Automatically notify Support: Yes

User response: 1. Reseat power supply n. 2. If the power-on LED is not lit and the power-supply error LED is lit, replace power supply n. 3. If both the power-on LED and the power-supply error LED are not lit, see Power problems for more information. (n = power supply number)

806f0108-0a02xxxx [PowerSupplyElementName] has Failed. (Power Supply 2)

Explanation: This message is for the use case when an implementation has detected a Power Supply has failed.

May also be shown as 806f01080a02xxxx or 0x806f01080a02xxxx

Severity: Error

Alert Category: Critical - Power

Serviceable: Yes

CIM Information: Prefix: PLAT and ID: 0086

SNMP Trap ID: 4

Automatically notify Support: Yes

User response: 1. Reseat power supply n. 2. If the power-on LED is not lit and the power-supply error LED is lit, replace power supply n. 3. If both the power-on LED and the power-supply error LED are not lit, see Power problems for more information. (n = power supply number)

806f0109-1381xxxx [PowerSupplyElementName] has been Power Cycled. (Host Power)

Explanation: This message is for the use case when an implementation has detected a Power Unit that has been power cycled.

May also be shown as 806f01091381xxxx or 0x806f01091381xxxx

Severity: Info

Alert Category: System - Other

Serviceable: No

CIM Information: Prefix: PLAT and ID: 0108

SNMP Trap ID:

Automatically notify Support: No

User response: No action; information only.

806f010c-2001xxxx Uncorrectable error detected for [PhysicalMemoryElementName] on Subsystem [MemoryElementName]. (DIMM 1)

Explanation: This message is for the use case when an implementation has detected a Memory uncorrectable error.

May also be shown as 806f010c2001xxxx or 0x806f010c2001xxxx

Severity: Error

Alert Category: Critical - Memory

Serviceable: Yes

CIM Information: Prefix: PLAT and ID: 0138

SNMP Trap ID: 41

Automatically notify Support: Yes

User response: 1. Check the IBM support website for an applicable retain tip or firmware update that applies to this memory error. 2. Swap the affected DIMMs (as indicated by the error LEDs on the system board or the event logs) to a different memory channel or microprocessor. 3. If the problem follows the DIMM, replace the failing DIMM. 4. (Trained technician only) If the problem occurs on the same DIMM connector, check the DIMM connector. If the connector contains any foreign material or is damaged, replace the system board. 5. (Trained technician only) Remove the affected microprocessor and check the microprocessor socket pins for any damaged pins. If a damage is found, replace the system board. 6. (Trained technician only) Replace the affected microprocessor. 7. Manually re-enable all affected DIMMs if the server firmware version is older than UEFI v1.10. If the server firmware version is UEFI v1.10 or newer, disconnect and reconnect the server to the power source and restart the server. 8. (Trained Service technician only) Replace the affected microprocessor.

806f010c-2002xxxx Uncorrectable error detected for [PhysicalMemoryElementName] on Subsystem [MemoryElementName]. (DIMM 2)

Explanation: This message is for the use case when an implementation has detected a Memory uncorrectable error.

May also be shown as 806f010c2002xxxx or 0x806f010c2002xxxx

Severity: Error

Alert Category: Critical - Memory

Serviceable: Yes

CIM Information: Prefix: PLAT and ID: 0138

SNMP Trap ID: 41

Automatically notify Support: Yes

User response: 1. Check the IBM support website for an applicable retain tip or firmware update that applies to this memory error. 2. Swap the affected DIMMs (as indicated by the error LEDs on the system board or the event logs) to a different memory channel or microprocessor. 3. If the problem follows the DIMM, replace the failing DIMM. 4. (Trained technician only) If the problem occurs on the same DIMM connector, check the DIMM connector. If the connector contains any foreign material or is damaged, replace the system board. 5. (Trained technician only) Remove the affected microprocessor and check the microprocessor socket pins for any damaged pins. If a damage is found, replace the system board. 6. (Trained technician only) Replace the affected microprocessor. 7. Manually re-enable all affected DIMMs if the server firmware version is older than UEFI v1.10. If the server firmware version is UEFI v1.10 or newer, disconnect and reconnect the server to the power source and restart the server. 8. (Trained Service technician only) Replace the affected microprocessor.

806f010c-2003xxxx Uncorrectable error detected for [PhysicalMemoryElementName] on Subsystem [MemoryElementName]. (DIMM 3)

Explanation: This message is for the use case when an implementation has detected a Memory uncorrectable error.

May also be shown as 806f010c2003xxxx or 0x806f010c2003xxxx

Severity: Error

Alert Category: Critical - Memory

Serviceable: Yes

CIM Information: Prefix: PLAT and ID: 0138

SNMP Trap ID: 41

Automatically notify Support: Yes

User response: 1. Check the IBM support website for an applicable retain tip or firmware update that applies to this memory error. 2. Swap the affected DIMMs (as indicated by the error LEDs on the system board or the event logs) to a different memory channel or microprocessor. 3. If the problem follows the DIMM, replace the failing DIMM. 4. (Trained technician only) If the problem occurs on the same DIMM connector, check the DIMM connector. If the connector contains any foreign material or is damaged, replace the system board. 5. (Trained technician only) Remove the affected microprocessor and check the microprocessor socket pins for any damaged pins. If a damage is found, replace the system board. 6. (Trained technician only) Replace the affected microprocessor. 7. Manually re-enable all affected DIMMs if the server firmware version is older than UEFI v1.10. If the server firmware version is UEFI v1.10 or newer, disconnect and reconnect the server to the power source and restart the server. 8. (Trained Service technician only) Replace the affected microprocessor.

806f010c-2004xxxx Uncorrectable error detected for [PhysicalMemoryElementName] on Subsystem [MemoryElementName]. (DIMM 4)

Explanation: This message is for the use case when an implementation has detected a Memory uncorrectable error.

May also be shown as 806f010c2004xxxx or 0x806f010c2004xxxx

Severity: Error

Alert Category: Critical - Memory

Serviceable: Yes

CIM Information: Prefix: PLAT and ID: 0138

SNMP Trap ID: 41

Automatically notify Support: Yes

User response: 1. Check the IBM support website for an applicable retain tip or firmware update that applies to this memory error. 2. Swap the affected DIMMs (as indicated by the error LEDs on the system board or the event logs) to a different memory channel or microprocessor. 3. If the problem follows the DIMM, replace the failing DIMM. 4. (Trained technician only) If the problem occurs on the same DIMM connector, check the DIMM connector. If the connector contains any foreign material or is damaged, replace the system board. 5. (Trained technician only) Remove the affected microprocessor and check the microprocessor socket pins for any damaged pins. If a damage is found, replace the system board. 6. (Trained technician only) Replace the affected microprocessor. 7. Manually re-enable all affected DIMMs if the server firmware version is older than UEFI v1.10. If the server firmware version is UEFI v1.10 or newer, disconnect and reconnect the server to the power source and restart the server. 8. (Trained Service technician only) Replace the affected microprocessor.

806f010c-2005xxxx Uncorrectable error detected for [PhysicalMemoryElementName] on Subsystem [MemoryElementName]. (DIMM 5)

Explanation: This message is for the use case when an implementation has detected a Memory uncorrectable error.

May also be shown as 806f010c2005xxxx or 0x806f010c2005xxxx

Severity: Error

Alert Category: Critical - Memory

Serviceable: Yes

CIM Information: Prefix: PLAT and ID: 0138

SNMP Trap ID: 41

Automatically notify Support: Yes

User response: 1. Check the IBM support website for an applicable retain tip or firmware update that applies to this memory error. 2. Swap the affected DIMMs (as indicated by the error LEDs on the system board or the event logs) to a different memory channel or microprocessor. 3. If the problem follows the DIMM, replace the failing DIMM. 4. (Trained technician only) If the problem occurs on the same DIMM connector, check the DIMM connector. If the connector contains any foreign material or is damaged, replace the system board. 5. (Trained technician only) Remove the affected microprocessor and check the microprocessor socket pins for any damaged pins. If a damage is found, replace the system board. 6. (Trained technician only) Replace the affected microprocessor. 7. Manually re-enable all affected DIMMs if the server firmware version is older than UEFI v1.10. If the server firmware version is UEFI v1.10 or newer, disconnect and reconnect the server to the power source and restart the server. 8. (Trained Service technician only) Replace the affected microprocessor.

806f010c-2006xxxx Uncorrectable error detected for [PhysicalMemoryElementName] on Subsystem [MemoryElementName]. (DIMM 6)

Explanation: This message is for the use case when an implementation has detected a Memory uncorrectable error.

May also be shown as 806f010c2006xxxx or 0x806f010c2006xxxx

Severity: Error

Alert Category: Critical - Memory

Serviceable: Yes

CIM Information: Prefix: PLAT and ID: 0138

SNMP Trap ID: 41

Automatically notify Support: Yes

User response: 1. Check the IBM support website for an applicable retain tip or firmware update that applies to this memory error. 2. Swap the affected DIMMs (as indicated by the error LEDs on the system board or the event logs) to a different memory channel or microprocessor. 3. If the problem follows the DIMM, replace the failing DIMM. 4. (Trained technician only) If the problem occurs on the same DIMM connector, check the DIMM connector. If the connector contains any foreign material or is damaged, replace the system board. 5. (Trained technician only) Remove the affected microprocessor and check the microprocessor socket pins for any damaged pins. If a damage is found, replace the system board. 6. (Trained technician only) Replace the affected microprocessor. 7. Manually re-enable all affected DIMMs if the server firmware version is older than UEFI v1.10. If the server firmware version is UEFI v1.10 or newer, disconnect and reconnect the server to the power source and restart the server. 8. (Trained Service technician only) Replace the affected microprocessor.

806f010c-2007xxxx Uncorrectable error detected for [PhysicalMemoryElementName] on Subsystem [MemoryElementName]. (DIMM 7)

Explanation: This message is for the use case when an implementation has detected a Memory uncorrectable error.

May also be shown as 806f010c2007xxxx or 0x806f010c2007xxxx

Severity: Error

Alert Category: Critical - Memory

Serviceable: Yes

CIM Information: Prefix: PLAT and ID: 0138

SNMP Trap ID: 41

Automatically notify Support: Yes

User response: 1. Check the IBM support website for an applicable retain tip or firmware update that applies to this memory error. 2. Swap the affected DIMMs (as indicated by the error LEDs on the system board or the event logs) to a different memory channel or microprocessor. 3. If the problem follows the DIMM, replace the failing DIMM. 4. (Trained technician only) If the problem occurs on the same DIMM connector, check the DIMM connector. If the connector contains any foreign material or is damaged, replace the system board. 5. (Trained technician only) Remove the affected microprocessor and check the microprocessor socket pins for any damaged pins. If a damage is found, replace the system board. 6. (Trained technician only) Replace the affected microprocessor. 7. Manually re-enable all affected DIMMs if the server firmware version is older than UEFI v1.10. If the server firmware version is UEFI v1.10 or newer, disconnect and reconnect the server to the power source and restart the server. 8. (Trained Service technician only) Replace the affected microprocessor.

806f010c-2008xxxx Uncorrectable error detected for [PhysicalMemoryElementName] on Subsystem [MemoryElementName]. (DIMM 8)

Explanation: This message is for the use case when an implementation has detected a Memory uncorrectable error.

May also be shown as 806f010c2008xxxx or 0x806f010c2008xxxx

Severity: Error

Alert Category: Critical - Memory

Serviceable: Yes

CIM Information: Prefix: PLAT and ID: 0138

SNMP Trap ID: 41

Automatically notify Support: Yes

User response: 1. Check the IBM support website for an applicable retain tip or firmware update that applies to this memory error. 2. Swap the affected DIMMs (as indicated by the error LEDs on the system board or the event logs) to a different memory channel or microprocessor. 3. If the problem follows the DIMM, replace the failing DIMM. 4. (Trained technician only) If the problem occurs on the same DIMM connector, check the DIMM connector. If the connector contains any foreign material or is damaged, replace the system board. 5. (Trained technician only) Remove the affected microprocessor and check the microprocessor socket pins for any damaged pins. If a damage is found, replace the system board. 6. (Trained technician only) Replace the affected microprocessor. 7. Manually re-enable all affected DIMMs if the server firmware version is older than UEFI v1.10. If the server firmware version is UEFI v1.10 or newer, disconnect and reconnect the server to the power source and restart the server. 8. (Trained Service technician only) Replace the affected microprocessor.

806f010c-2009xxxx Uncorrectable error detected for [PhysicalMemoryElementName] on Subsystem [MemoryElementName]. (DIMM 9)

Explanation: This message is for the use case when an implementation has detected a Memory uncorrectable error.

May also be shown as 806f010c2009xxxx or 0x806f010c2009xxxx

Severity: Error

Alert Category: Critical - Memory

Serviceable: Yes

CIM Information: Prefix: PLAT and ID: 0138

SNMP Trap ID: 41

Automatically notify Support: Yes

User response: 1. Check the IBM support website for an applicable retain tip or firmware update that applies to this memory error. 2. Swap the affected DIMMs (as indicated by the error LEDs on the system board or the event logs) to a different memory channel or microprocessor. 3. If the problem follows the DIMM, replace the failing DIMM. 4. (Trained technician only) If the problem occurs on the same DIMM connector, check the DIMM connector. If the connector contains any foreign material or is damaged, replace the system board. 5. (Trained technician only) Remove the affected microprocessor and check the microprocessor socket pins for any damaged pins. If a damage is found, replace the system board. 6. (Trained technician only) Replace the affected microprocessor. 7. Manually re-enable all affected DIMMs if the server firmware version is older than UEFI v1.10. If the server firmware version is UEFI v1.10 or newer, disconnect and reconnect the server to the power source and restart the server. 8. (Trained Service technician only) Replace the affected microprocessor.

806f010c-200axxxx Uncorrectable error detected for [PhysicalMemoryElementName] on Subsystem [MemoryElementName]. (DIMM 10)

Explanation: This message is for the use case when an implementation has detected a Memory uncorrectable error.

May also be shown as 806f010c200axxxx or 0x806f010c200axxxx

Severity: Error

Alert Category: Critical - Memory

Serviceable: Yes

CIM Information: Prefix: PLAT and ID: 0138

SNMP Trap ID: 41

Automatically notify Support: Yes

User response: 1. Check the IBM support website for an applicable retain tip or firmware update that applies to this memory error. 2. Swap the affected DIMMs (as indicated by the error LEDs on the system board or the event logs) to a different memory channel or microprocessor. 3. If the problem follows the DIMM, replace the failing DIMM. 4. (Trained technician only) If the problem occurs on the same DIMM connector, check the DIMM connector. If the connector contains any foreign material or is damaged, replace the system board. 5. (Trained technician only) Remove the affected microprocessor and check the microprocessor socket pins for any damaged pins. If a damage is found, replace the system board. 6. (Trained technician only) Replace the affected microprocessor. 7. Manually re-enable all affected DIMMs if the server firmware version is older than UEFI v1.10. If the server firmware version is UEFI v1.10 or newer, disconnect and reconnect the server to the power source and restart the server. 8. (Trained Service technician only) Replace the affected microprocessor.

806f010c-200bxxxx Uncorrectable error detected for [PhysicalMemoryElementName] on Subsystem [MemoryElementName]. (DIMM 11)

Explanation: This message is for the use case when an implementation has detected a Memory uncorrectable error.

May also be shown as 806f010c200bxxxx or 0x806f010c200bxxxx

Severity: Error

Alert Category: Critical - Memory

Serviceable: Yes

CIM Information: Prefix: PLAT and ID: 0138

SNMP Trap ID: 41

Automatically notify Support: Yes

User response: 1. Check the IBM support website for an applicable retain tip or firmware update that applies to this memory error. 2. Swap the affected DIMMs (as indicated by the error LEDs on the system board or the event logs) to a different memory channel or microprocessor. 3. If the problem follows the DIMM, replace the failing DIMM. 4. (Trained technician only) If the problem occurs on the same DIMM connector, check the DIMM connector. If the connector contains any foreign material or is damaged, replace the system board. 5. (Trained technician only) Remove the affected microprocessor and check the microprocessor socket pins for any damaged pins. If a damage is found, replace the system board. 6. (Trained technician only) Replace the affected microprocessor. 7. Manually re-enable all affected DIMMs if the server firmware version is older than UEFI v1.10. If the server firmware version is UEFI v1.10 or newer, disconnect and reconnect the server to the power source and restart the server. 8. (Trained Service technician only) Replace the affected microprocessor.

806f010c-200cxxxx Uncorrectable error detected for [PhysicalMemoryElementName] on Subsystem [MemoryElementName]. (DIMM 12)

Explanation: This message is for the use case when an implementation has detected a Memory uncorrectable error.

May also be shown as 806f010c200cxxxx or 0x806f010c200cxxxx

Severity: Error

Alert Category: Critical - Memory

Serviceable: Yes

CIM Information: Prefix: PLAT and ID: 0138

SNMP Trap ID: 41

Automatically notify Support: Yes

User response: 1. Check the IBM support website for an applicable retain tip or firmware update that applies to this memory error. 2. Swap the affected DIMMs (as indicated by the error LEDs on the system board or the event logs) to a different memory channel or microprocessor. 3. If the problem follows the DIMM, replace the failing DIMM. 4. (Trained technician only) If the problem occurs on the same DIMM connector, check the DIMM connector. If the connector contains any foreign material or is damaged, replace the system board. 5. (Trained technician only) Remove the affected microprocessor and check the microprocessor socket pins for any damaged pins. If a damage is found, replace the system board. 6. (Trained technician only) Replace the affected microprocessor. 7. Manually re-enable all affected DIMMs if the server firmware version is older than UEFI v1.10. If the server firmware version is UEFI v1.10 or newer, disconnect and reconnect the server to the power source and restart the server. 8. (Trained Service technician only) Replace the affected microprocessor.

806f010c-200dxxxx Uncorrectable error detected for [PhysicalMemoryElementName] on Subsystem [MemoryElementName]. (DIMM 13)

Explanation: This message is for the use case when an implementation has detected a Memory uncorrectable error.

May also be shown as 806f010c200dxxxx or 0x806f010c200dxxxx

Severity: Error

Alert Category: Critical - Memory

Serviceable: Yes

CIM Information: Prefix: PLAT and ID: 0138

SNMP Trap ID: 41

Automatically notify Support: Yes

User response: 1. Check the IBM support website for an applicable retain tip or firmware update that applies to this memory error. 2. Swap the affected DIMMs (as indicated by the error LEDs on the system board or the event logs) to a different memory channel or microprocessor. 3. If the problem follows the DIMM, replace the failing DIMM. 4. (Trained technician only) If the problem occurs on the same DIMM connector, check the DIMM connector. If the connector contains any foreign material or is damaged, replace the system board. 5. (Trained technician only) Remove the affected microprocessor and check the microprocessor socket pins for any damaged pins. If a damage is found, replace the system board. 6. (Trained technician only) Replace the affected microprocessor. 7. Manually re-enable all affected DIMMs if the server firmware version is older than UEFI v1.10. If the server firmware version is UEFI v1.10 or newer, disconnect and reconnect the server to the power source and restart the server. 8. (Trained Service technician only) Replace the affected microprocessor.

806f010c-200exxxx Uncorrectable error detected for [PhysicalMemoryElementName] on Subsystem [MemoryElementName]. (DIMM 14)

Explanation: This message is for the use case when an implementation has detected a Memory uncorrectable error.

May also be shown as 806f010c200exxxx or 0x806f010c200exxxx

Severity: Error

Alert Category: Critical - Memory

Serviceable: Yes

CIM Information: Prefix: PLAT and ID: 0138

SNMP Trap ID: 41

Automatically notify Support: Yes

User response: 1. Check the IBM support website for an applicable retain tip or firmware update that applies to this memory error. 2. Swap the affected DIMMs (as indicated by the error LEDs on the system board or the event logs) to a different memory channel or microprocessor. 3. If the problem follows the DIMM, replace the failing DIMM. 4. (Trained technician only) If the problem occurs on the same DIMM connector, check the DIMM connector. If the connector contains any foreign material or is damaged, replace the system board. 5. (Trained technician only) Remove the affected microprocessor and check the microprocessor socket pins for any damaged pins. If a damage is found, replace the system board. 6. (Trained technician only) Replace the affected microprocessor. 7. Manually re-enable all affected DIMMs if the server firmware version is older than UEFI v1.10. If the server firmware version is UEFI v1.10 or newer, disconnect and reconnect the server to the power source and restart the server. 8. (Trained Service technician only) Replace the affected microprocessor.

806f010c-200fxxxx Uncorrectable error detected for [PhysicalMemoryElementName] on Subsystem [MemoryElementName]. (DIMM 15)

Explanation: This message is for the use case when an implementation has detected a Memory uncorrectable error.

May also be shown as 806f010c200fxxxx or 0x806f010c200fxxxx

Severity: Error

Alert Category: Critical - Memory

Serviceable: Yes

CIM Information: Prefix: PLAT and ID: 0138

SNMP Trap ID: 41

Automatically notify Support: Yes

User response: 1. Check the IBM support website for an applicable retain tip or firmware update that applies to this memory error. 2. Swap the affected DIMMs (as indicated by the error LEDs on the system board or the event logs) to a different memory channel or microprocessor. 3. If the problem follows the DIMM, replace the failing DIMM. 4. (Trained technician only) If the problem occurs on the same DIMM connector, check the DIMM connector. If the connector contains any foreign material or is damaged, replace the system board. 5. (Trained technician only) Remove the affected microprocessor and check the microprocessor socket pins for any damaged pins. If a damage is found, replace the system board. 6. (Trained technician only) Replace the affected microprocessor. 7. Manually re-enable all affected DIMMs if the server firmware version is older than UEFI v1.10. If the server firmware version is UEFI v1.10 or newer, disconnect and reconnect the server to the power source and restart the server. 8. (Trained Service technician only) Replace the affected microprocessor.

806f010c-2010xxxx Uncorrectable error detected for [PhysicalMemoryElementName] on Subsystem [MemoryElementName]. (DIMM 16)

Explanation: This message is for the use case when an implementation has detected a Memory uncorrectable error.

May also be shown as 806f010c2010xxxx or 0x806f010c2010xxxx

Severity: Error

Alert Category: Critical - Memory

Serviceable: Yes

CIM Information: Prefix: PLAT and ID: 0138

SNMP Trap ID: 41

Automatically notify Support: Yes

User response: 1. Check the IBM support website for an applicable retain tip or firmware update that applies to this memory error. 2. Swap the affected DIMMs (as indicated by the error LEDs on the system board or the event logs) to a different memory channel or microprocessor. 3. If the problem follows the DIMM, replace the failing DIMM. 4. (Trained technician only) If the problem occurs on the same DIMM connector, check the DIMM connector. If the connector contains any foreign material or is damaged, replace the system board. 5. (Trained technician only) Remove the affected microprocessor and check the microprocessor socket pins for any damaged pins. If a damage is found, replace the system board. 6. (Trained technician only) Replace the affected microprocessor. 7. Manually re-enable all affected DIMMs if the server firmware version is older than UEFI v1.10. If the server firmware version is UEFI v1.10 or newer, disconnect and reconnect the server to the power source and restart the server. 8. (Trained Service technician only) Replace the affected microprocessor.

806f010c-2011xxxx Uncorrectable error detected for [PhysicalMemoryElementName] on Subsystem [MemoryElementName]. (DIMM 17)

Explanation: This message is for the use case when an implementation has detected a Memory uncorrectable error.

May also be shown as 806f010c2011xxxx or 0x806f010c2011xxxx

Severity: Error

Alert Category: Critical - Memory

Serviceable: Yes

CIM Information: Prefix: PLAT and ID: 0138

SNMP Trap ID: 41

Automatically notify Support: Yes

User response: 1. Check the IBM support website for an applicable retain tip or firmware update that applies to this memory error. 2. Swap the affected DIMMs (as indicated by the error LEDs on the system board or the event logs) to a different memory channel or microprocessor. 3. If the problem follows the DIMM, replace the failing DIMM. 4. (Trained technician only) If the problem occurs on the same DIMM connector, check the DIMM connector. If the connector contains any foreign material or is damaged, replace the system board. 5. (Trained technician only) Remove the affected microprocessor and check the microprocessor socket pins for any damaged pins. If a damage is found, replace the system board. 6. (Trained technician only) Replace the affected microprocessor. 7. Manually re-enable all affected DIMMs if the server firmware version is older than UEFI v1.10. If the server firmware version is UEFI v1.10 or newer, disconnect and reconnect the server to the power source and restart the server. 8. (Trained Service technician only) Replace the affected microprocessor.

806f010c-2012xxxx Uncorrectable error detected for [PhysicalMemoryElementName] on Subsystem [MemoryElementName]. (DIMM 18)

Explanation: This message is for the use case when an implementation has detected a Memory uncorrectable error.

May also be shown as 806f010c2012xxxx or 0x806f010c2012xxxx

Severity: Error

Alert Category: Critical - Memory

Serviceable: Yes

CIM Information: Prefix: PLAT and ID: 0138

SNMP Trap ID: 41

Automatically notify Support: Yes

User response: 1. Check the IBM support website for an applicable retain tip or firmware update that applies to this memory error. 2. Swap the affected DIMMs (as indicated by the error LEDs on the system board or the event logs) to a different memory channel or microprocessor. 3. If the problem follows the DIMM, replace the failing DIMM. 4. (Trained technician only) If the problem occurs on the same DIMM connector, check the DIMM connector. If the connector contains any foreign material or is damaged, replace the system board. 5. (Trained technician only) Remove the affected microprocessor and check the microprocessor socket pins for any damaged pins. If a damage is found, replace the system board. 6. (Trained technician only) Replace the affected microprocessor. 7. Manually re-enable all affected DIMMs if the server firmware version is older than UEFI v1.10. If the server firmware version is UEFI v1.10 or newer, disconnect and reconnect the server to the power source and restart the server. 8. (Trained Service technician only) Replace the affected microprocessor.

806f010c-2581xxxx Uncorrectable error detected for [PhysicalMemoryElementName] on Subsystem [MemoryElementName]. (All DIMMS)

Explanation: This message is for the use case when an implementation has detected a Memory uncorrectable error.

May also be shown as 806f010c2581xxxx or 0x806f010c2581xxxx

Severity: Error

Alert Category: Critical - Memory

Serviceable: Yes

CIM Information: Prefix: PLAT and ID: 0138

SNMP Trap ID: 41

Automatically notify Support: Yes

User response: 1. Check the IBM support website for an applicable retain tip or firmware update that applies to this memory error. 2. Swap the affected DIMMs (as indicated by the error LEDs on the system board or the event logs) to a different memory channel or microprocessor. 3. If the problem follows the DIMM, replace the failing DIMM. 4. (Trained technician only) If the problem occurs on the same DIMM connector, check the DIMM connector. If the connector contains any foreign material or is damaged, replace the system board. 5. (Trained technician only) Remove the affected microprocessor and check the microprocessor socket pins for any damaged pins. If a damage is found, replace the system board. 6. (Trained technician only) Replace the affected microprocessor. 7. Manually re-enable all affected DIMMs if the server firmware version is older than UEFI v1.10. If the server firmware version is UEFI v1.10 or newer, disconnect and reconnect the server to the power source and restart the server. 8. (Trained Service technician only) Replace the affected microprocessor. One of the DIMMs :

806f010d-0400xxxx The Drive [StorageVolumeElementName] has been disabled due to a detected fault. (Drive 0)

Explanation: This message is for the use case when an implementation has detected a Drive was Disabled due to fault.

May also be shown as 806f010d0400xxxx or 0x806f010d0400xxxx

Severity: Error

Alert Category: Critical - Hard Disk drive

Serviceable: Yes

CIM Information: Prefix: PLAT and ID: 0164

SNMP Trap ID: 5

Automatically notify Support: Yes

User response: 1. Run the hard disk drive diagnostic test on drive n. 2. Reseat the following components: a. Hard disk drive (wait 1 minute or more before reinstalling the drive) b. Cable from the system board to the backplane 3. Replace the following components one at a time, in the order shown, restarting the server each time: a. Hard disk drive b. Cable from the system board to the backplane c. Hard disk drive backplane (n = hard disk drive number)

806f010d-0401xxxx The Drive [StorageVolumeElementName] has been disabled due to a detected fault. (Drive 1)

Explanation: This message is for the use case when an implementation has detected a Drive was Disabled due to fault.

May also be shown as 806f010d0401xxxx or 0x806f010d0401xxxx

Severity: Error

Alert Category: Critical - Hard Disk drive

Serviceable: Yes

CIM Information: Prefix: PLAT and ID: 0164

SNMP Trap ID: 5

Automatically notify Support: Yes

User response: 1. Run the hard disk drive diagnostic test on drive n. 2. Reseat the following components: a. Hard disk drive (wait 1 minute or more before reinstalling the drive) b. Cable from the system board to the backplane 3. Replace the following components one at a time, in the order shown, restarting the server each time: a. Hard disk drive b. Cable from the system board to the backplane c. Hard disk drive backplane (n = hard disk drive number)

806f010d-0402xxxx The Drive [StorageVolumeElementName] has been disabled due to a detected fault. (Drive 2)

Explanation: This message is for the use case when an implementation has detected a Drive was Disabled due to fault.

May also be shown as 806f010d0402xxxx or 0x806f010d0402xxxx

Severity: Error

Alert Category: Critical - Hard Disk drive

Serviceable: Yes

CIM Information: Prefix: PLAT and ID: 0164

SNMP Trap ID: 5

Automatically notify Support: Yes

User response: 1. Run the hard disk drive diagnostic test on drive n. 2. Reseat the following components: a. Hard disk drive (wait 1 minute or more before reinstalling the drive) b. Cable from the system board to the backplane 3. Replace the following components one at a time, in the order shown, restarting the server each time: a. Hard disk drive b. Cable from the system board to the backplane c. Hard disk drive backplane (n = hard disk drive number)

806f010d-0403xxxx The Drive [StorageVolumeElementName] has been disabled due to a detected fault. (Drive 3)

Explanation: This message is for the use case when an implementation has detected a Drive was Disabled due to fault.

May also be shown as 806f010d0403xxxx or 0x806f010d0403xxxx

Severity: Error

Alert Category: Critical - Hard Disk drive

Serviceable: Yes

CIM Information: Prefix: PLAT and ID: 0164

SNMP Trap ID: 5

Automatically notify Support: Yes

User response: 1. Run the hard disk drive diagnostic test on drive n. 2. Reseat the following components: a. Hard disk drive (wait 1 minute or more before reinstalling the drive) b. Cable from the system board to the backplane 3. Replace the following components one at a time, in the order shown, restarting the server each time: a. Hard disk drive b. Cable from the system board to the backplane c. Hard disk drive backplane (n = hard disk drive number)

806f010d-0404xxxx The Drive [StorageVolumeElementName] has been disabled due to a detected fault. (Drive 4)

Explanation: This message is for the use case when an implementation has detected a Drive was Disabled due to fault.

May also be shown as 806f010d0404xxxx or 0x806f010d0404xxxx

Severity: Error

Alert Category: Critical - Hard Disk drive

Serviceable: Yes

CIM Information: Prefix: PLAT and ID: 0164

SNMP Trap ID: 5

Automatically notify Support: Yes

User response: 1. Run the hard disk drive diagnostic test on drive n. 2. Reseat the following components: a. Hard disk drive (wait 1 minute or more before reinstalling the drive) b. Cable from the system board to the backplane 3. Replace the following components one at a time, in the order shown, restarting the server each time: a. Hard disk drive b. Cable from the system board to the backplane c. Hard disk drive backplane (n = hard disk drive number)

806f010d-0405xxxx The Drive [StorageVolumeElementName] has been disabled due to a detected fault. (Drive 5)

Explanation: This message is for the use case when an implementation has detected a Drive was Disabled due to fault.

May also be shown as 806f010d0405xxxx or 0x806f010d0405xxxx

Severity: Error

Alert Category: Critical - Hard Disk drive

Serviceable: Yes

CIM Information: Prefix: PLAT and ID: 0164

SNMP Trap ID: 5

Automatically notify Support: Yes

User response: 1. Run the hard disk drive diagnostic test on drive n. 2. Reseat the following components: a. Hard disk drive (wait 1 minute or more before reinstalling the drive) b. Cable from the system board to the backplane 3. Replace the following components one at a time, in the order shown, restarting the server each time: a. Hard disk drive b. Cable from the system board to the backplane c. Hard disk drive backplane (n = hard disk drive number)

806f010d-0406xxxx The Drive [StorageVolumeElementName] has been disabled due to a detected fault. (Drive 6)

Explanation: This message is for the use case when an implementation has detected a Drive was Disabled due to fault.

May also be shown as 806f010d0406xxxx or 0x806f010d0406xxxx

Severity: Error

Alert Category: Critical - Hard Disk drive

Serviceable: Yes

CIM Information: Prefix: PLAT and ID: 0164

SNMP Trap ID: 5

Automatically notify Support: Yes

User response: 1. Run the hard disk drive diagnostic test on drive n. 2. Reseat the following components: a. Hard disk drive (wait 1 minute or more before reinstalling the drive) b. Cable from the system board to the backplane 3. Replace the following components one at a time, in the order shown, restarting the server each time: a. Hard disk drive b. Cable from the system board to the backplane c. Hard disk drive backplane (n = hard disk drive number)

806f010d-0407xxxx The Drive [StorageVolumeElementName] has been disabled due to a detected fault. (Drive 7)

Explanation: This message is for the use case when an implementation has detected a Drive was Disabled due to fault.

May also be shown as 806f010d0407xxxx or 0x806f010d0407xxxx

Severity: Error

Alert Category: Critical - Hard Disk drive

Serviceable: Yes

CIM Information: Prefix: PLAT and ID: 0164

SNMP Trap ID: 5

Automatically notify Support: Yes

User response: 1. Run the hard disk drive diagnostic test on drive n. 2. Reseat the following components: a. Hard disk drive (wait 1 minute or more before reinstalling the drive) b. Cable from the system board to the backplane 3. Replace the following components one at a time, in the order shown, restarting the server each time: a. Hard disk drive b. Cable from the system board to the backplane c. Hard disk drive backplane (n = hard disk drive number)

806f010f-2201xxxx The System [ComputerSystemElementName] encountered a firmware hang. (Firmware Error)

Explanation: This message is for the use case when an implementation has detected a System Firmware Hang.

May also be shown as 806f010f2201xxxx or 0x806f010f2201xxxx

Severity: Error

Alert Category: System - Boot failure

Serviceable: Yes

CIM Information: Prefix: PLAT and ID: 0186

SNMP Trap ID: 25

Automatically notify Support: No

User response: 1. Make sure the server meets the minimum configuration to start (see Power-supply LEDs). 2. Update the server firmware on the primary page. Important: Some cluster solutions require specific code levels or coordinated code updates. If the device is part of a cluster solution, verify that the latest level of code is supported for the cluster solution before you update the code. 3. (Trained technician only) Replace the system board.

806f011b-0701xxxx The connector [PhysicalConnectorElementName] has encountered a configuration error. (Video USB)

Explanation: This message is for the use case when an implementation has detected an Interconnect Configuration Error.

May also be shown as 806f011b0701xxxx or 0x806f011b0701xxxx

Severity: Error

Alert Category: Critical - Other

Serviceable: Yes

CIM Information: Prefix: PLAT and ID: 0266

SNMP Trap ID: 50

Automatically notify Support: Yes

User response: 1. Reseat the power paddle cable on the system board. 2. Replace the power paddle cable. 3. (Trained technician only) Replace the system board.

**806f0123-2101xxxx Reboot of system [ComputerSystemElementName] initiated by [WatchdogElementName].
(Watchdog)**

Explanation: This message is for the use case when an implementation has detected a Reboot by a Watchdog occurred.

May also be shown as 806f01232101xxxx or 0x806f01232101xxxx

Severity: Info

Alert Category: System - Other

Serviceable: No

CIM Information: **Prefix:** PLAT and **ID:** 0370

SNMP Trap ID:

Automatically notify Support: No

User response: No action; information only.

806f0125-0b01xxxx [ManagedElementName] detected as absent. (SAS Riser)

Explanation: This message is for the use case when an implementation has detected a Managed Element is Absent.

May also be shown as 806f01250b01xxxx or 0x806f01250b01xxxx

Severity: Info

Alert Category: System - Other

Serviceable: No

CIM Information: **Prefix:** PLAT and **ID:** 0392

SNMP Trap ID:

Automatically notify Support: No

User response: No action; information only.

806f0125-0b02xxxx [ManagedElementName] detected as absent. (PCI Riser 1)

Explanation: This message is for the use case when an implementation has detected a Managed Element is Absent.

May also be shown as 806f01250b02xxxx or 0x806f01250b02xxxx

Severity: Info

Alert Category: System - Other

Serviceable: No

CIM Information: **Prefix:** PLAT and **ID:** 0392

SNMP Trap ID:

Automatically notify Support: No

User response: No action; information only.

806f0125-0b03xxxx [ManagedElementName] detected as absent. (PCI Riser 2)

Explanation: This message is for the use case when an implementation has detected a Managed Element is Absent.

May also be shown as 806f01250b03xxxx or 0x806f01250b03xxxx

Severity: Info

Alert Category: System - Other

Serviceable: No

CIM Information: Prefix: PLAT and ID: 0392

SNMP Trap ID:

Automatically notify Support: No

User response: No action; information only.

806f0125-0c01xxxx [ManagedElementName] detected as absent. (Front Panel)

Explanation: This message is for the use case when an implementation has detected a Managed Element is Absent.

May also be shown as 806f01250c01xxxx or 0x806f01250c01xxxx

Severity: Info

Alert Category: System - Other

Serviceable: No

CIM Information: Prefix: PLAT and ID: 0392

SNMP Trap ID:

Automatically notify Support: No

User response: No action; information only.

806f0125-1d01xxxx [ManagedElementName] detected as absent. (Fan 1)

Explanation: This message is for the use case when an implementation has detected a Managed Element is Absent.

May also be shown as 806f01251d01xxxx or 0x806f01251d01xxxx

Severity: Info

Alert Category: System - Other

Serviceable: No

CIM Information: Prefix: PLAT and ID: 0392

SNMP Trap ID:

Automatically notify Support: No

User response: No action; information only.

806f0125-1d02xxxx • 806f0125-1d04xxxx

806f0125-1d02xxxx [ManagedElementName] detected as absent. (Fan 2)

Explanation: This message is for the use case when an implementation has detected a Managed Element is Absent.

May also be shown as 806f01251d02xxxx or 0x806f01251d02xxxx

Severity: Info

Alert Category: System - Other

Serviceable: No

CIM Information: Prefix: PLAT and ID: 0392

SNMP Trap ID:

Automatically notify Support: No

User response: No action; information only.

806f0125-1d03xxxx [ManagedElementName] detected as absent. (Fan 3)

Explanation: This message is for the use case when an implementation has detected a Managed Element is Absent.

May also be shown as 806f01251d03xxxx or 0x806f01251d03xxxx

Severity: Info

Alert Category: System - Other

Serviceable: No

CIM Information: Prefix: PLAT and ID: 0392

SNMP Trap ID:

Automatically notify Support: No

User response: No action; information only.

806f0125-1d04xxxx [ManagedElementName] detected as absent. (Fan 4)

Explanation: This message is for the use case when an implementation has detected a Managed Element is Absent.

May also be shown as 806f01251d04xxxx or 0x806f01251d04xxxx

Severity: Info

Alert Category: System - Other

Serviceable: No

CIM Information: Prefix: PLAT and ID: 0392

SNMP Trap ID:

Automatically notify Support: No

User response: No action; information only.

806f0125-1d05xxxx [ManagedElementName] detected as absent. (Fan 5)

Explanation: This message is for the use case when an implementation has detected a Managed Element is Absent.

May also be shown as 806f01251d05xxxx or 0x806f01251d05xxxx

Severity: Info

Alert Category: System - Other

Serviceable: No

CIM Information: Prefix: PLAT and ID: 0392

SNMP Trap ID:

Automatically notify Support: No

User response: No action; information only.

806f0125-1d06xxxx [ManagedElementName] detected as absent. (Fan 6)

Explanation: This message is for the use case when an implementation has detected a Managed Element is Absent.

May also be shown as 806f01251d06xxxx or 0x806f01251d06xxxx

Severity: Info

Alert Category: System - Other

Serviceable: No

CIM Information: Prefix: PLAT and ID: 0392

SNMP Trap ID:

Automatically notify Support: No

User response: No action; information only.

806f0207-0301xxxx [ProcessorElementName] has Failed with FRB1/BIST condition. (CPU 1)

Explanation: This message is for the use case when an implementation has detected a Processor Failed - FRB1/BIST condition.

May also be shown as 806f02070301xxxx or 0x806f02070301xxxx

Severity: Error

Alert Category: Critical - CPU

Serviceable: Yes

CIM Information: Prefix: PLAT and ID: 0044

SNMP Trap ID: 40

Automatically notify Support: Yes

User response: 1. Make sure that the latest levels of firmware and device drivers are installed for all adapters and standard devices, such as Ethernet, SCSI, and SAS. Important: Some cluster solutions require specific code levels or coordinated code updates. If the device is part of a cluster solution, verify that the latest level of code is supported for the cluster solution before you update the code. 2. Update the firmware (UEFI and IMM) to the latest level (Updating the firmware). 3. Run the DSA program. 4. Reseat the adapter. 5. Replace the adapter. 6. (Trained technician only) Replace microprocessor n. 7. (Trained technician only) Replace the system board. (n = microprocessor number)

806f0207-0302xxxx [ProcessorElementName] has Failed with FRB1/BIST condition. (CPU 2)

Explanation: This message is for the use case when an implementation has detected a Processor Failed - FRB1/BIST condition.

May also be shown as 806f02070302xxxx or 0x806f02070302xxxx

Severity: Error

Alert Category: Critical - CPU

Serviceable: Yes

CIM Information: Prefix: PLAT and ID: 0044

SNMP Trap ID: 40

Automatically notify Support: Yes

User response: 1. Make sure that the latest levels of firmware and device drivers are installed for all adapters and standard devices, such as Ethernet, SCSI, and SAS. Important: Some cluster solutions require specific code levels or coordinated code updates. If the device is part of a cluster solution, verify that the latest level of code is supported for the cluster solution before you update the code. 2. Update the firmware (UEFI and IMM) to the latest level (Updating the firmware). 3. Run the DSA program. 4. Reseat the adapter. 5. Replace the adapter. 6. (Trained technician only) Replace microprocessor n. 7. (Trained technician only) Replace the system board. (n = microprocessor number)

806f020d-0400xxxx Failure Predicted on drive [StorageVolumeElementName] for array
[ComputerSystemElementName]. (Drive 0)

Explanation: This message is for the use case when an implementation has detected an Array Failure is Predicted.

May also be shown as 806f020d0400xxxx or 0x806f020d0400xxxx

Severity: Warning

Alert Category: System - Predicted Failure

Serviceable: Yes

CIM Information: Prefix: PLAT and ID: 0168

SNMP Trap ID: 27

Automatically notify Support: Yes

User response: 1. Run the hard disk drive diagnostic test on drive n. 2. Reseat the following components: a. Hard disk drive b. Cable from the system board to the backplane. 3. Replace the following components one at a time, in the order shown, restarting the server each time: a. Hard disk drive. b. Cable from the system board to the backplane. c. Hard disk drive backplane. (n = hard disk drive number)

806f020d-0401xxxx Failure Predicted on drive [StorageVolumeElementName] for array [ComputerSystemElementName]. (Drive 1)

Explanation: This message is for the use case when an implementation has detected an Array Failure is Predicted.

May also be shown as 806f020d0401xxxx or 0x806f020d0401xxxx

Severity: Warning

Alert Category: System - Predicted Failure

Serviceable: Yes

CIM Information: Prefix: PLAT and ID: 0168

SNMP Trap ID: 27

Automatically notify Support: Yes

User response: 1. Run the hard disk drive diagnostic test on drive n. 2. Reseat the following components: a. Hard disk drive b. Cable from the system board to the backplane. 3. Replace the following components one at a time, in the order shown, restarting the server each time: a. Hard disk drive. b. Cable from the system board to the backplane. c. Hard disk drive backplane. (n = hard disk drive number)

806f020d-0402xxxx Failure Predicted on drive [StorageVolumeElementName] for array [ComputerSystemElementName]. (Drive 2)

Explanation: This message is for the use case when an implementation has detected an Array Failure is Predicted.

May also be shown as 806f020d0402xxxx or 0x806f020d0402xxxx

Severity: Warning

Alert Category: System - Predicted Failure

Serviceable: Yes

CIM Information: Prefix: PLAT and ID: 0168

SNMP Trap ID: 27

Automatically notify Support: Yes

User response: 1. Run the hard disk drive diagnostic test on drive n. 2. Reseat the following components: a. Hard disk drive b. Cable from the system board to the backplane. 3. Replace the following components one at a time, in the order shown, restarting the server each time: a. Hard disk drive. b. Cable from the system board to the backplane. c. Hard disk drive backplane. (n = hard disk drive number)

806f020d-0403xxxx Failure Predicted on drive [StorageVolumeElementName] for array [ComputerSystemElementName]. (Drive 3)

Explanation: This message is for the use case when an implementation has detected an Array Failure is Predicted.

May also be shown as 806f020d0403xxxx or 0x806f020d0403xxxx

Severity: Warning

Alert Category: System - Predicted Failure

Serviceable: Yes

CIM Information: Prefix: PLAT and ID: 0168

SNMP Trap ID: 27

Automatically notify Support: Yes

User response: 1. Run the hard disk drive diagnostic test on drive n. 2. Reseat the following components: a. Hard disk drive b. Cable from the system board to the backplane. 3. Replace the following components one at a time, in the order shown, restarting the server each time: a. Hard disk drive. b. Cable from the system board to the backplane. c. Hard disk drive backplane. (n = hard disk drive number)

806f020d-0404xxxx Failure Predicted on drive [StorageVolumeElementName] for array [ComputerSystemElementName]. (Drive 4)

Explanation: This message is for the use case when an implementation has detected an Array Failure is Predicted. May also be shown as 806f020d0404xxxx or 0x806f020d0404xxxx

Severity: Warning

Alert Category: System - Predicted Failure

Serviceable: Yes

CIM Information: Prefix: PLAT and ID: 0168

SNMP Trap ID: 27

Automatically notify Support: Yes

User response: 1. Run the hard disk drive diagnostic test on drive n. 2. Reseat the following components: a. Hard disk drive b. Cable from the system board to the backplane. 3. Replace the following components one at a time, in the order shown, restarting the server each time: a. Hard disk drive. b. Cable from the system board to the backplane. c. Hard disk drive backplane. (n = hard disk drive number)

806f020d-0405xxxx Failure Predicted on drive [StorageVolumeElementName] for array [ComputerSystemElementName]. (Drive 5)

Explanation: This message is for the use case when an implementation has detected an Array Failure is Predicted. May also be shown as 806f020d0405xxxx or 0x806f020d0405xxxx

Severity: Warning

Alert Category: System - Predicted Failure

Serviceable: Yes

CIM Information: Prefix: PLAT and ID: 0168

SNMP Trap ID: 27

Automatically notify Support: Yes

User response: 1. Run the hard disk drive diagnostic test on drive n. 2. Reseat the following components: a. Hard disk drive b. Cable from the system board to the backplane. 3. Replace the following components one at a time, in the order shown, restarting the server each time: a. Hard disk drive. b. Cable from the system board to the backplane. c. Hard disk drive backplane. (n = hard disk drive number)

806f020d-0406xxxx Failure Predicted on drive [StorageVolumeElementName] for array [ComputerSystemElementName]. (Drive 6)

Explanation: This message is for the use case when an implementation has detected an Array Failure is Predicted. May also be shown as 806f020d0406xxxx or 0x806f020d0406xxxx

Severity: Warning

Alert Category: System - Predicted Failure

Serviceable: Yes

CIM Information: Prefix: PLAT and ID: 0168

SNMP Trap ID: 27

Automatically notify Support: Yes

User response: 1. Run the hard disk drive diagnostic test on drive n. 2. Reseat the following components: a. Hard disk drive b. Cable from the system board to the backplane. 3. Replace the following components one at a time, in the order shown, restarting the server each time: a. Hard disk drive. b. Cable from the system board to the backplane. c. Hard disk drive backplane. (n = hard disk drive number)

806f020d-0407xxxx Failure Predicted on drive [StorageVolumeElementName] for array [ComputerSystemElementName]. (Drive 7)

Explanation: This message is for the use case when an implementation has detected an Array Failure is Predicted.

May also be shown as 806f020d0407xxxx or 0x806f020d0407xxxx

Severity: Warning

Alert Category: System - Predicted Failure

Serviceable: Yes

CIM Information: Prefix: PLAT and ID: 0168

SNMP Trap ID: 27

Automatically notify Support: Yes

User response: 1. Run the hard disk drive diagnostic test on drive n. 2. Reseat the following components: a. Hard disk drive b. Cable from the system board to the backplane. 3. Replace the following components one at a time, in the order shown, restarting the server each time: a. Hard disk drive. b. Cable from the system board to the backplane. c. Hard disk drive backplane. (n = hard disk drive number)

806f0212-2584xxxx The System [ComputerSystemElementName] has encountered an unknown system hardware fault. (CPU Fault Reboot)

Explanation: This message is for the use case when an implementation has detected an Unknown System Hardware Failure.

May also be shown as 806f02122584xxxx or 0x806f02122584xxxx

Severity: Error

Alert Category: Critical - Other

Serviceable: Yes

CIM Information: Prefix: PLAT and ID: 0214

SNMP Trap ID: 50

Automatically notify Support: Yes

User response: 1. Make sure that the fans are operating, that there are no obstructions to the airflow (front and rear of the server), that the air baffles are in place and correctly installed, and that the server cover is installed and completely closed. 2. Make sure that the heat sink for microprocessor n is installed correctly. 3. (Trained technician only) Replace microprocessor n. (n = microprocessor number)

806f0223-2101xxxx Powering off system [ComputerSystemElementName] initiated by [WatchdogElementName]. (Watchdog)

Explanation: This message is for the use case when an implementation has detected a Poweroff by Watchdog has occurred.

May also be shown as 806f02232101xxxx or 0x806f02232101xxxx

Severity: Info

Alert Category: System - Other

Serviceable: No

CIM Information: Prefix: PLAT and ID: 0372

SNMP Trap ID:

Automatically notify Support: No

User response: No action; information only.

806f0308-0a01xxxx [PowerSupplyElementName] has lost input. (Power Supply 1)

Explanation: This message is for the use case when an implementation has detected a Power Supply that has input that has been lost.

May also be shown as 806f03080a01xxxx or 0x806f03080a01xxxx

Severity: Info

Alert Category: System - Other

Serviceable: No

CIM Information: Prefix: PLAT and ID: 0100

SNMP Trap ID:

Automatically notify Support: No

User response: 1. Reconnect the power cords. 2. Check power supply n LED. 3. See Power-supply LEDs for more information. (n = power supply number)

806f0308-0a02xxxx [PowerSupplyElementName] has lost input. (Power Supply 2)

Explanation: This message is for the use case when an implementation has detected a Power Supply that has input that has been lost.

May also be shown as 806f03080a02xxxx or 0x806f03080a02xxxx

Severity: Info

Alert Category: System - Other

Serviceable: No

CIM Information: Prefix: PLAT and ID: 0100

SNMP Trap ID:

Automatically notify Support: No

User response: 1. Reconnect the power cords. 2. Check power supply n LED. 3. See Power-supply LEDs for more information. (n = power supply number)

806f030c-2001xxxx Scrub Failure for [PhysicalMemoryElementName] on Subsystem [MemoryElementName]. (DIMM 1)

Explanation: This message is for the use case when an implementation has detected a Memory Scrub failure.

May also be shown as 806f030c2001xxxx or 0x806f030c2001xxxx

Severity: Error

Alert Category: Critical - Memory

Serviceable: Yes

CIM Information: Prefix: PLAT and ID: 0136

SNMP Trap ID: 41

Automatically notify Support: No

User response: Note: Each time you install or remove a DIMM, you must disconnect the server from the power source; then, wait 10 seconds before restarting the server. 1. Check the IBM support website for an applicable retain tip or firmware update that applies to this memory error. 2. Make sure that the DIMMs are firmly seated and no foreign material is found in the DIMM connector. Then, retry with the same DIMM. 3. If the problem is related to a DIMM, replace the failing DIMM indicated by the error LEDs. 4. If the problem occurs on the same DIMM connector, swap the affected DIMMs (as indicated by the error LEDs on the system board or the event logs) to a different memory channel or microprocessor. 5. (Trained technician only) If the problem occurs on the same DIMM connector, check the DIMM connector. If the connector contains any foreign material or is damaged, replace the system board. 6. (Trained service technician only) Remove the affected microprocessor and check the microprocessor socket pins for

any damaged pins. If a damage is found, replace the system board. 7. (Trained service technician only) If the problem is related to microprocessor socket pins, replace the system board.

**806f030c-2002xxxx Scrub Failure for [PhysicalMemoryElementName] on Subsystem [MemoryElementName].
(DIMM 2)**

Explanation: This message is for the use case when an implementation has detected a Memory Scrub failure.

May also be shown as 806f030c2002xxxx or 0x806f030c2002xxxx

Severity: Error

Alert Category: Critical - Memory

Serviceable: Yes

CIM Information: Prefix: PLAT and ID: 0136

SNMP Trap ID: 41

Automatically notify Support: No

User response: Note: Each time you install or remove a DIMM, you must disconnect the server from the power source; then, wait 10 seconds before restarting the server. 1. Check the IBM support website for an applicable retain tip or firmware update that applies to this memory error. 2. Make sure that the DIMMs are firmly seated and no foreign material is found in the DIMM connector. Then, retry with the same DIMM. 3. If the problem is related to a DIMM, replace the failing DIMM indicated by the error LEDs. 4. If the problem occurs on the same DIMM connector, swap the affected DIMMs (as indicated by the error LEDs on the system board or the event logs) to a different memory channel or microprocessor. 5. (Trained technician only) If the problem occurs on the same DIMM connector, check the DIMM connector. If the connector contains any foreign material or is damaged, replace the system board. 6. (Trained service technician only) Remove the affected microprocessor and check the microprocessor socket pins for any damaged pins. If a damage is found, replace the system board. 7. (Trained service technician only) If the problem is related to microprocessor socket pins, replace the system board.

**806f030c-2003xxxx Scrub Failure for [PhysicalMemoryElementName] on Subsystem [MemoryElementName].
(DIMM 3)**

Explanation: This message is for the use case when an implementation has detected a Memory Scrub failure.

May also be shown as 806f030c2003xxxx or 0x806f030c2003xxxx

Severity: Error

Alert Category: Critical - Memory

Serviceable: Yes

CIM Information: Prefix: PLAT and ID: 0136

SNMP Trap ID: 41

Automatically notify Support: No

User response: Note: Each time you install or remove a DIMM, you must disconnect the server from the power source; then, wait 10 seconds before restarting the server. 1. Check the IBM support website for an applicable retain tip or firmware update that applies to this memory error. 2. Make sure that the DIMMs are firmly seated and no foreign material is found in the DIMM connector. Then, retry with the same DIMM. 3. If the problem is related to a DIMM, replace the failing DIMM indicated by the error LEDs. 4. If the problem occurs on the same DIMM connector, swap the affected DIMMs (as indicated by the error LEDs on the system board or the event logs) to a different memory channel or microprocessor. 5. (Trained technician only) If the problem occurs on the same DIMM connector, check the DIMM connector. If the connector contains any foreign material or is damaged, replace the system board. 6. (Trained service technician only) Remove the affected microprocessor and check the microprocessor socket pins for any damaged pins. If a damage is found, replace the system board. 7. (Trained service technician only) If the problem is related to microprocessor socket pins, replace the system board.

**806f030c-2004xxxx Scrub Failure for [PhysicalMemoryElementName] on Subsystem [MemoryElementName].
(DIMM 4)**

Explanation: This message is for the use case when an implementation has detected a Memory Scrub failure.

May also be shown as 806f030c2004xxxx or 0x806f030c2004xxxx

Severity: Error

Alert Category: Critical - Memory

Serviceable: Yes

CIM Information: Prefix: PLAT and ID: 0136

SNMP Trap ID: 41

Automatically notify Support: No

User response: Note: Each time you install or remove a DIMM, you must disconnect the server from the power source; then, wait 10 seconds before restarting the server. 1. Check the IBM support website for an applicable retain tip or firmware update that applies to this memory error. 2. Make sure that the DIMMs are firmly seated and no foreign material is found in the DIMM connector. Then, retry with the same DIMM. 3. If the problem is related to a DIMM, replace the failing DIMM indicated by the error LEDs. 4. If the problem occurs on the same DIMM connector, swap the affected DIMMs (as indicated by the error LEDs on the system board or the event logs) to a different memory channel or microprocessor. 5. (Trained technician only) If the problem occurs on the same DIMM connector, check the DIMM connector. If the connector contains any foreign material or is damaged, replace the system board. 6. (Trained service technician only) Remove the affected microprocessor and check the microprocessor socket pins for any damaged pins. If a damage is found, replace the system board. 7. (Trained service technician only) If the problem is related to microprocessor socket pins, replace the system board.

**806f030c-2005xxxx Scrub Failure for [PhysicalMemoryElementName] on Subsystem [MemoryElementName].
(DIMM 5)**

Explanation: This message is for the use case when an implementation has detected a Memory Scrub failure.

May also be shown as 806f030c2005xxxx or 0x806f030c2005xxxx

Severity: Error

Alert Category: Critical - Memory

Serviceable: Yes

CIM Information: Prefix: PLAT and ID: 0136

SNMP Trap ID: 41

Automatically notify Support: No

User response: Note: Each time you install or remove a DIMM, you must disconnect the server from the power source; then, wait 10 seconds before restarting the server. 1. Check the IBM support website for an applicable retain tip or firmware update that applies to this memory error. 2. Make sure that the DIMMs are firmly seated and no foreign material is found in the DIMM connector. Then, retry with the same DIMM. 3. If the problem is related to a DIMM, replace the failing DIMM indicated by the error LEDs. 4. If the problem occurs on the same DIMM connector, swap the affected DIMMs (as indicated by the error LEDs on the system board or the event logs) to a different memory channel or microprocessor. 5. (Trained technician only) If the problem occurs on the same DIMM connector, check the DIMM connector. If the connector contains any foreign material or is damaged, replace the system board. 6. (Trained service technician only) Remove the affected microprocessor and check the microprocessor socket pins for any damaged pins. If a damage is found, replace the system board. 7. (Trained service technician only) If the problem is related to microprocessor socket pins, replace the system board.

**806f030c-2006xxxx Scrub Failure for [PhysicalMemoryElementName] on Subsystem [MemoryElementName].
(DIMM 6)**

Explanation: This message is for the use case when an implementation has detected a Memory Scrub failure.

May also be shown as 806f030c2006xxxx or 0x806f030c2006xxxx

Severity: Error

Alert Category: Critical - Memory

Serviceable: Yes

CIM Information: Prefix: PLAT and ID: 0136

SNMP Trap ID: 41

Automatically notify Support: No

User response: Note: Each time you install or remove a DIMM, you must disconnect the server from the power source; then, wait 10 seconds before restarting the server. 1. Check the IBM support website for an applicable retain tip or firmware update that applies to this memory error. 2. Make sure that the DIMMs are firmly seated and no foreign material is found in the DIMM connector. Then, retry with the same DIMM. 3. If the problem is related to a DIMM, replace the failing DIMM indicated by the error LEDs. 4. If the problem occurs on the same DIMM connector, swap the affected DIMMs (as indicated by the error LEDs on the system board or the event logs) to a different memory channel or microprocessor. 5. (Trained technician only) If the problem occurs on the same DIMM connector, check the DIMM connector. If the connector contains any foreign material or is damaged, replace the system board. 6. (Trained service technician only) Remove the affected microprocessor and check the microprocessor socket pins for any damaged pins. If a damage is found, replace the system board. 7. (Trained service technician only) If the problem is related to microprocessor socket pins, replace the system board.

**806f030c-2007xxxx Scrub Failure for [PhysicalMemoryElementName] on Subsystem [MemoryElementName].
(DIMM 7)**

Explanation: This message is for the use case when an implementation has detected a Memory Scrub failure.

May also be shown as 806f030c2007xxxx or 0x806f030c2007xxxx

Severity: Error

Alert Category: Critical - Memory

Serviceable: Yes

CIM Information: Prefix: PLAT and ID: 0136

SNMP Trap ID: 41

Automatically notify Support: No

User response: Note: Each time you install or remove a DIMM, you must disconnect the server from the power source; then, wait 10 seconds before restarting the server. 1. Check the IBM support website for an applicable retain tip or firmware update that applies to this memory error. 2. Make sure that the DIMMs are firmly seated and no foreign material is found in the DIMM connector. Then, retry with the same DIMM. 3. If the problem is related to a DIMM, replace the failing DIMM indicated by the error LEDs. 4. If the problem occurs on the same DIMM connector, swap the affected DIMMs (as indicated by the error LEDs on the system board or the event logs) to a different memory channel or microprocessor. 5. (Trained technician only) If the problem occurs on the same DIMM connector, check the DIMM connector. If the connector contains any foreign material or is damaged, replace the system board. 6. (Trained service technician only) Remove the affected microprocessor and check the microprocessor socket pins for any damaged pins. If a damage is found, replace the system board. 7. (Trained service technician only) If the problem is related to microprocessor socket pins, replace the system board.

**806f030c-2008xxxx Scrub Failure for [PhysicalMemoryElementName] on Subsystem [MemoryElementName].
(DIMM 8)**

Explanation: This message is for the use case when an implementation has detected a Memory Scrub failure.

May also be shown as 806f030c2008xxxx or 0x806f030c2008xxxx

Severity: Error

Alert Category: Critical - Memory

Serviceable: Yes

CIM Information: Prefix: PLAT and ID: 0136

SNMP Trap ID: 41

Automatically notify Support: No

User response: Note: Each time you install or remove a DIMM, you must disconnect the server from the power source; then, wait 10 seconds before restarting the server. 1. Check the IBM support website for an applicable retain tip or firmware update that applies to this memory error. 2. Make sure that the DIMMs are firmly seated and no foreign material is found in the DIMM connector. Then, retry with the same DIMM. 3. If the problem is related to a DIMM, replace the failing DIMM indicated by the error LEDs. 4. If the problem occurs on the same DIMM connector, swap the affected DIMMs (as indicated by the error LEDs on the system board or the event logs) to a different memory channel or microprocessor. 5. (Trained technician only) If the problem occurs on the same DIMM connector, check the DIMM connector. If the connector contains any foreign material or is damaged, replace the system board. 6. (Trained service technician only) Remove the affected microprocessor and check the microprocessor socket pins for any damaged pins. If a damage is found, replace the system board. 7. (Trained service technician only) If the problem is related to microprocessor socket pins, replace the system board.

**806f030c-2009xxxx Scrub Failure for [PhysicalMemoryElementName] on Subsystem [MemoryElementName].
(DIMM 9)**

Explanation: This message is for the use case when an implementation has detected a Memory Scrub failure.

May also be shown as 806f030c2009xxxx or 0x806f030c2009xxxx

Severity: Error

Alert Category: Critical - Memory

Serviceable: Yes

CIM Information: Prefix: PLAT and ID: 0136

SNMP Trap ID: 41

Automatically notify Support: No

User response: Note: Each time you install or remove a DIMM, you must disconnect the server from the power source; then, wait 10 seconds before restarting the server. 1. Check the IBM support website for an applicable retain tip or firmware update that applies to this memory error. 2. Make sure that the DIMMs are firmly seated and no foreign material is found in the DIMM connector. Then, retry with the same DIMM. 3. If the problem is related to a DIMM, replace the failing DIMM indicated by the error LEDs. 4. If the problem occurs on the same DIMM connector, swap the affected DIMMs (as indicated by the error LEDs on the system board or the event logs) to a different memory channel or microprocessor. 5. (Trained technician only) If the problem occurs on the same DIMM connector, check the DIMM connector. If the connector contains any foreign material or is damaged, replace the system board. 6. (Trained service technician only) Remove the affected microprocessor and check the microprocessor socket pins for any damaged pins. If a damage is found, replace the system board. 7. (Trained service technician only) If the problem is related to microprocessor socket pins, replace the system board.

**806f030c-200axxxx Scrub Failure for [PhysicalMemoryElementName] on Subsystem [MemoryElementName].
(DIMM 10)**

Explanation: This message is for the use case when an implementation has detected a Memory Scrub failure.

May also be shown as 806f030c200axxxx or 0x806f030c200axxxx

Severity: Error

Alert Category: Critical - Memory

Serviceable: Yes

CIM Information: Prefix: PLAT and ID: 0136

SNMP Trap ID: 41

Automatically notify Support: No

User response: Note: Each time you install or remove a DIMM, you must disconnect the server from the power source; then, wait 10 seconds before restarting the server. 1. Check the IBM support website for an applicable retain tip or firmware update that applies to this memory error. 2. Make sure that the DIMMs are firmly seated and no foreign material is found in the DIMM connector. Then, retry with the same DIMM. 3. If the problem is related to a DIMM, replace the failing DIMM indicated by the error LEDs. 4. If the problem occurs on the same DIMM connector, swap the affected DIMMs (as indicated by the error LEDs on the system board or the event logs) to a different memory channel or microprocessor. 5. (Trained technician only) If the problem occurs on the same DIMM connector, check the DIMM connector. If the connector contains any foreign material or is damaged, replace the system board. 6. (Trained service technician only) Remove the affected microprocessor and check the microprocessor socket pins for any damaged pins. If a damage is found, replace the system board. 7. (Trained service technician only) If the problem is related to microprocessor socket pins, replace the system board.

**806f030c-200bxxxx Scrub Failure for [PhysicalMemoryElementName] on Subsystem [MemoryElementName].
(DIMM 11)**

Explanation: This message is for the use case when an implementation has detected a Memory Scrub failure.

May also be shown as 806f030c200bxxxx or 0x806f030c200bxxxx

Severity: Error

Alert Category: Critical - Memory

Serviceable: Yes

CIM Information: Prefix: PLAT and ID: 0136

SNMP Trap ID: 41

Automatically notify Support: No

User response: Note: Each time you install or remove a DIMM, you must disconnect the server from the power source; then, wait 10 seconds before restarting the server. 1. Check the IBM support website for an applicable retain tip or firmware update that applies to this memory error. 2. Make sure that the DIMMs are firmly seated and no foreign material is found in the DIMM connector. Then, retry with the same DIMM. 3. If the problem is related to a DIMM, replace the failing DIMM indicated by the error LEDs. 4. If the problem occurs on the same DIMM connector, swap the affected DIMMs (as indicated by the error LEDs on the system board or the event logs) to a different memory channel or microprocessor. 5. (Trained technician only) If the problem occurs on the same DIMM connector, check the DIMM connector. If the connector contains any foreign material or is damaged, replace the system board. 6. (Trained service technician only) Remove the affected microprocessor and check the microprocessor socket pins for any damaged pins. If a damage is found, replace the system board. 7. (Trained service technician only) If the problem is related to microprocessor socket pins, replace the system board.

**806f030c-200cxxxx Scrub Failure for [PhysicalMemoryElementName] on Subsystem [MemoryElementName].
(DIMM 12)**

Explanation: This message is for the use case when an implementation has detected a Memory Scrub failure.

May also be shown as 806f030c200cxxxx or 0x806f030c200cxxxx

Severity: Error

Alert Category: Critical - Memory

Serviceable: Yes

CIM Information: Prefix: PLAT and ID: 0136

SNMP Trap ID: 41

Automatically notify Support: No

User response: Note: Each time you install or remove a DIMM, you must disconnect the server from the power source; then, wait 10 seconds before restarting the server. 1. Check the IBM support website for an applicable retain tip or firmware update that applies to this memory error. 2. Make sure that the DIMMs are firmly seated and no foreign material is found in the DIMM connector. Then, retry with the same DIMM. 3. If the problem is related to a DIMM, replace the failing DIMM indicated by the error LEDs. 4. If the problem occurs on the same DIMM connector, swap the affected DIMMs (as indicated by the error LEDs on the system board or the event logs) to a different memory channel or microprocessor. 5. (Trained technician only) If the problem occurs on the same DIMM connector, check the DIMM connector. If the connector contains any foreign material or is damaged, replace the system board. 6. (Trained service technician only) Remove the affected microprocessor and check the microprocessor socket pins for any damaged pins. If a damage is found, replace the system board. 7. (Trained service technician only) If the problem is related to microprocessor socket pins, replace the system board.

**806f030c-200dxxxx Scrub Failure for [PhysicalMemoryElementName] on Subsystem [MemoryElementName].
(DIMM 13)**

Explanation: This message is for the use case when an implementation has detected a Memory Scrub failure.

May also be shown as 806f030c200dxxxx or 0x806f030c200dxxxx

Severity: Error

Alert Category: Critical - Memory

Serviceable: Yes

CIM Information: Prefix: PLAT and ID: 0136

SNMP Trap ID: 41

Automatically notify Support: No

User response: Note: Each time you install or remove a DIMM, you must disconnect the server from the power source; then, wait 10 seconds before restarting the server. 1. Check the IBM support website for an applicable retain tip or firmware update that applies to this memory error. 2. Make sure that the DIMMs are firmly seated and no foreign material is found in the DIMM connector. Then, retry with the same DIMM. 3. If the problem is related to a DIMM, replace the failing DIMM indicated by the error LEDs. 4. If the problem occurs on the same DIMM connector, swap the affected DIMMs (as indicated by the error LEDs on the system board or the event logs) to a different memory channel or microprocessor. 5. (Trained technician only) If the problem occurs on the same DIMM connector, check the DIMM connector. If the connector contains any foreign material or is damaged, replace the system board. 6. (Trained service technician only) Remove the affected microprocessor and check the microprocessor socket pins for any damaged pins. If a damage is found, replace the system board. 7. (Trained service technician only) If the problem is related to microprocessor socket pins, replace the system board.

**806f030c-200exxxx Scrub Failure for [PhysicalMemoryElementName] on Subsystem [MemoryElementName].
(DIMM 14)**

Explanation: This message is for the use case when an implementation has detected a Memory Scrub failure.

May also be shown as 806f030c200exxxx or 0x806f030c200exxxx

Severity: Error

Alert Category: Critical - Memory

Serviceable: Yes

CIM Information: Prefix: PLAT and ID: 0136

SNMP Trap ID: 41

Automatically notify Support: No

User response: Note: Each time you install or remove a DIMM, you must disconnect the server from the power source; then, wait 10 seconds before restarting the server. 1. Check the IBM support website for an applicable retain tip or firmware update that applies to this memory error. 2. Make sure that the DIMMs are firmly seated and no foreign material is found in the DIMM connector. Then, retry with the same DIMM. 3. If the problem is related to a DIMM, replace the failing DIMM indicated by the error LEDs. 4. If the problem occurs on the same DIMM connector, swap the affected DIMMs (as indicated by the error LEDs on the system board or the event logs) to a different memory channel or microprocessor. 5. (Trained technician only) If the problem occurs on the same DIMM connector, check the DIMM connector. If the connector contains any foreign material or is damaged, replace the system board. 6. (Trained service technician only) Remove the affected microprocessor and check the microprocessor socket pins for any damaged pins. If a damage is found, replace the system board. 7. (Trained service technician only) If the problem is related to microprocessor socket pins, replace the system board.

**806f030c-200fxxxx Scrub Failure for [PhysicalMemoryElementName] on Subsystem [MemoryElementName].
(DIMM 15)**

Explanation: This message is for the use case when an implementation has detected a Memory Scrub failure.

May also be shown as 806f030c200fxxxx or 0x806f030c200fxxxx

Severity: Error

Alert Category: Critical - Memory

Serviceable: Yes

CIM Information: Prefix: PLAT and ID: 0136

SNMP Trap ID: 41

Automatically notify Support: No

User response: Note: Each time you install or remove a DIMM, you must disconnect the server from the power source; then, wait 10 seconds before restarting the server. 1. Check the IBM support website for an applicable retain tip or firmware update that applies to this memory error. 2. Make sure that the DIMMs are firmly seated and no foreign material is found in the DIMM connector. Then, retry with the same DIMM. 3. If the problem is related to a DIMM, replace the failing DIMM indicated by the error LEDs. 4. If the problem occurs on the same DIMM connector, swap the affected DIMMs (as indicated by the error LEDs on the system board or the event logs) to a different memory channel or microprocessor. 5. (Trained technician only) If the problem occurs on the same DIMM connector, check the DIMM connector. If the connector contains any foreign material or is damaged, replace the system board. 6. (Trained service technician only) Remove the affected microprocessor and check the microprocessor socket pins for any damaged pins. If a damage is found, replace the system board. 7. (Trained service technician only) If the problem is related to microprocessor socket pins, replace the system board.

806f030c-2010xxxx Scrub Failure for [PhysicalMemoryElementName] on Subsystem [MemoryElementName].
(DIMM 16)

Explanation: This message is for the use case when an implementation has detected a Memory Scrub failure.

May also be shown as 806f030c2010xxxx or 0x806f030c2010xxxx

Severity: Error

Alert Category: Critical - Memory

Serviceable: Yes

CIM Information: Prefix: PLAT and ID: 0136

SNMP Trap ID: 41

Automatically notify Support: No

User response: Note: Each time you install or remove a DIMM, you must disconnect the server from the power source; then, wait 10 seconds before restarting the server. 1. Check the IBM support website for an applicable retain tip or firmware update that applies to this memory error. 2. Make sure that the DIMMs are firmly seated and no foreign material is found in the DIMM connector. Then, retry with the same DIMM. 3. If the problem is related to a DIMM, replace the failing DIMM indicated by the error LEDs. 4. If the problem occurs on the same DIMM connector, swap the affected DIMMs (as indicated by the error LEDs on the system board or the event logs) to a different memory channel or microprocessor. 5. (Trained technician only) If the problem occurs on the same DIMM connector, check the DIMM connector. If the connector contains any foreign material or is damaged, replace the system board. 6. (Trained service technician only) Remove the affected microprocessor and check the microprocessor socket pins for any damaged pins. If a damage is found, replace the system board. 7. (Trained service technician only) If the problem is related to microprocessor socket pins, replace the system board.

806f030c-2011xxxx Scrub Failure for [PhysicalMemoryElementName] on Subsystem [MemoryElementName].
(DIMM 17)

Explanation: This message is for the use case when an implementation has detected a Memory Scrub failure.

May also be shown as 806f030c2011xxxx or 0x806f030c2011xxxx

Severity: Error

Alert Category: Critical - Memory

Serviceable: Yes

CIM Information: Prefix: PLAT and ID: 0136

SNMP Trap ID: 41

Automatically notify Support: No

User response: Note: Each time you install or remove a DIMM, you must disconnect the server from the power source; then, wait 10 seconds before restarting the server. 1. Check the IBM support website for an applicable retain tip or firmware update that applies to this memory error. 2. Make sure that the DIMMs are firmly seated and no foreign material is found in the DIMM connector. Then, retry with the same DIMM. 3. If the problem is related to a DIMM, replace the failing DIMM indicated by the error LEDs. 4. If the problem occurs on the same DIMM connector, swap the affected DIMMs (as indicated by the error LEDs on the system board or the event logs) to a different memory channel or microprocessor. 5. (Trained technician only) If the problem occurs on the same DIMM connector, check the DIMM connector. If the connector contains any foreign material or is damaged, replace the system board. 6. (Trained service technician only) Remove the affected microprocessor and check the microprocessor socket pins for any damaged pins. If a damage is found, replace the system board. 7. (Trained service technician only) If the problem is related to microprocessor socket pins, replace the system board.

806f030c-2012xxxx Scrub Failure for [PhysicalMemoryElementName] on Subsystem [MemoryElementName]. (DIMM 18)

Explanation: This message is for the use case when an implementation has detected a Memory Scrub failure.

May also be shown as 806f030c2012xxxx or 0x806f030c2012xxxx

Severity: Error

Alert Category: Critical - Memory

Serviceable: Yes

CIM Information: Prefix: PLAT and ID: 0136

SNMP Trap ID: 41

Automatically notify Support: No

User response: Note: Each time you install or remove a DIMM, you must disconnect the server from the power source; then, wait 10 seconds before restarting the server. 1. Check the IBM support website for an applicable retain tip or firmware update that applies to this memory error. 2. Make sure that the DIMMs are firmly seated and no foreign material is found in the DIMM connector. Then, retry with the same DIMM. 3. If the problem is related to a DIMM, replace the failing DIMM indicated by the error LEDs. 4. If the problem occurs on the same DIMM connector, swap the affected DIMMs (as indicated by the error LEDs on the system board or the event logs) to a different memory channel or microprocessor. 5. (Trained technician only) If the problem occurs on the same DIMM connector, check the DIMM connector. If the connector contains any foreign material or is damaged, replace the system board. 6. (Trained service technician only) Remove the affected microprocessor and check the microprocessor socket pins for any damaged pins. If a damage is found, replace the system board. 7. (Trained service technician only) If the problem is related to microprocessor socket pins, replace the system board.

806f030c-2581xxxx Scrub Failure for [PhysicalMemoryElementName] on Subsystem [MemoryElementName]. (ALL DIMMS)

Explanation: This message is for the use case when an implementation has detected a Memory Scrub failure.

May also be shown as 806f030c2581xxxx or 0x806f030c2581xxxx

Severity: Error

Alert Category: Critical - Memory

Serviceable: Yes

CIM Information: Prefix: PLAT and ID: 0136

SNMP Trap ID: 41

Automatically notify Support: No

User response: Note: Each time you install or remove a DIMM, you must disconnect the server from the power source; then, wait 10 seconds before restarting the server. 1. Check the IBM support website for an applicable retain tip or firmware update that applies to this memory error. 2. Make sure that the DIMMs are firmly seated and no foreign material is found in the DIMM connector. Then, retry with the same DIMM. 3. If the problem is related to a DIMM, replace the failing DIMM indicated by the error LEDs. 4. If the problem occurs on the same DIMM connector, swap the affected DIMMs (as indicated by the error LEDs on the system board or the event logs) to a different memory channel or microprocessor. 5. (Trained technician only) If the problem occurs on the same DIMM connector, check the DIMM connector. If the connector contains any foreign material or is damaged, replace the system board. 6. (Trained service technician only) Remove the affected microprocessor and check the microprocessor socket pins for any damaged pins. If a damage is found, replace the system board. 7. (Trained service technician only) If the problem is related to microprocessor socket pins, replace the system board. One of the DIMMs :

806f0313-1701xxxx A software NMI has occurred on system [ComputerSystemElementName]. (NMI State)

Explanation: This message is for the use case when an implementation has detected a Software NMI.

May also be shown as 806f03131701xxxx or 0x806f03131701xxxx

Severity: Error

Alert Category: Critical - Other

Serviceable: Yes

CIM Information: Prefix: PLAT and ID: 0228

SNMP Trap ID: 50

Automatically notify Support: No

User response: 1. Check the device driver. 2. Reinstall the device driver. 3. Update all device drivers to the latest level. 4. Update the firmware (UEFI and IMM).

806f0323-2101xxxx Power cycle of system [ComputerSystemElementName] initiated by watchdog [WatchdogElementName]. (Watchdog)

Explanation: This message is for the use case when an implementation has detected a Power Cycle by Watchdog occurred.

May also be shown as 806f03232101xxxx or 0x806f03232101xxxx

Severity: Info

Alert Category: System - Other

Serviceable: No

CIM Information: Prefix: PLAT and ID: 0374

SNMP Trap ID:

Automatically notify Support: No

User response: No action; information only.

806f040c-2001xxxx [PhysicalMemoryElementName] Disabled on Subsystem [MemoryElementName]. (DIMM 1)

Explanation: This message is for the use case when an implementation has detected that Memory has been Disabled.

May also be shown as 806f040c2001xxxx or 0x806f040c2001xxxx

Severity: Info

Alert Category: System - Other

Serviceable: No

CIM Information: Prefix: PLAT and ID: 0131

SNMP Trap ID:

Automatically notify Support: No

User response: 1. Make sure the DIMM is installed correctly. 2. If the DIMM was disabled because of a memory fault (memory uncorrectable error or memory logging limit reached), follow the suggested actions for that error event and restart the server. 3. Check the IBM support website for an applicable retain tip or firmware update that applies to this memory event. If no memory fault is recorded in the logs and no DIMM connector error LED is lit, you can re-enable the DIMM through the Setup utility or the Advanced Settings Utility (ASU).

806f040c-2002xxxx [PhysicalMemoryElementName] Disabled on Subsystem [MemoryElementName]. (DIMM 2)

Explanation: This message is for the use case when an implementation has detected that Memory has been Disabled.

May also be shown as 806f040c2002xxxx or 0x806f040c2002xxxx

Severity: Info

Alert Category: System - Other

Serviceable: No

CIM Information: Prefix: PLAT and ID: 0131

SNMP Trap ID:

Automatically notify Support: No

User response: 1. Make sure the DIMM is installed correctly. 2. If the DIMM was disabled because of a memory fault (memory uncorrectable error or memory logging limit reached), follow the suggested actions for that error event and restart the server. 3. Check the IBM support website for an applicable retain tip or firmware update that applies to this memory event. If no memory fault is recorded in the logs and no DIMM connector error LED is lit, you can re-enable the DIMM through the Setup utility or the Advanced Settings Utility (ASU).

806f040c-2003xxxx [PhysicalMemoryElementName] Disabled on Subsystem [MemoryElementName]. (DIMM 3)

Explanation: This message is for the use case when an implementation has detected that Memory has been Disabled.

May also be shown as 806f040c2003xxxx or 0x806f040c2003xxxx

Severity: Info

Alert Category: System - Other

Serviceable: No

CIM Information: Prefix: PLAT and ID: 0131

SNMP Trap ID:

Automatically notify Support: No

User response: 1. Make sure the DIMM is installed correctly. 2. If the DIMM was disabled because of a memory fault (memory uncorrectable error or memory logging limit reached), follow the suggested actions for that error event and restart the server. 3. Check the IBM support website for an applicable retain tip or firmware update that applies to this memory event. If no memory fault is recorded in the logs and no DIMM connector error LED is lit, you can re-enable the DIMM through the Setup utility or the Advanced Settings Utility (ASU).

806f040c-2004xxxx [PhysicalMemoryElementName] Disabled on Subsystem [MemoryElementName]. (DIMM 4)

Explanation: This message is for the use case when an implementation has detected that Memory has been Disabled.

May also be shown as 806f040c2004xxxx or 0x806f040c2004xxxx

Severity: Info

Alert Category: System - Other

Serviceable: No

CIM Information: Prefix: PLAT and ID: 0131

SNMP Trap ID:

Automatically notify Support: No

User response: 1. Make sure the DIMM is installed correctly. 2. If the DIMM was disabled because of a memory fault (memory uncorrectable error or memory logging limit reached), follow the suggested actions for that error event and restart the server. 3. Check the IBM support website for an applicable retain tip or firmware update that applies

806f040c-2005xxxx • 806f040c-2006xxxx

to this memory event. If no memory fault is recorded in the logs and no DIMM connector error LED is lit, you can re-enable the DIMM through the Setup utility or the Advanced Settings Utility (ASU).

806f040c-2005xxxx [PhysicalMemoryElementName] Disabled on Subsystem [MemoryElementName]. (DIMM 5)

Explanation: This message is for the use case when an implementation has detected that Memory has been Disabled.

May also be shown as 806f040c2005xxxx or 0x806f040c2005xxxx

Severity: Info

Alert Category: System - Other

Serviceable: No

CIM Information: Prefix: PLAT and ID: 0131

SNMP Trap ID:

Automatically notify Support: No

User response: 1. Make sure the DIMM is installed correctly. 2. If the DIMM was disabled because of a memory fault (memory uncorrectable error or memory logging limit reached), follow the suggested actions for that error event and restart the server. 3. Check the IBM support website for an applicable retain tip or firmware update that applies to this memory event. If no memory fault is recorded in the logs and no DIMM connector error LED is lit, you can re-enable the DIMM through the Setup utility or the Advanced Settings Utility (ASU).

806f040c-2006xxxx [PhysicalMemoryElementName] Disabled on Subsystem [MemoryElementName]. (DIMM 6)

Explanation: This message is for the use case when an implementation has detected that Memory has been Disabled.

May also be shown as 806f040c2006xxxx or 0x806f040c2006xxxx

Severity: Info

Alert Category: System - Other

Serviceable: No

CIM Information: Prefix: PLAT and ID: 0131

SNMP Trap ID:

Automatically notify Support: No

User response: 1. Make sure the DIMM is installed correctly. 2. If the DIMM was disabled because of a memory fault (memory uncorrectable error or memory logging limit reached), follow the suggested actions for that error event and restart the server. 3. Check the IBM support website for an applicable retain tip or firmware update that applies to this memory event. If no memory fault is recorded in the logs and no DIMM connector error LED is lit, you can re-enable the DIMM through the Setup utility or the Advanced Settings Utility (ASU).

806f040c-2007xxxx [PhysicalMemoryElementName] Disabled on Subsystem [MemoryElementName]. (DIMM 7)

Explanation: This message is for the use case when an implementation has detected that Memory has been Disabled.

May also be shown as 806f040c2007xxxx or 0x806f040c2007xxxx

Severity: Info

Alert Category: System - Other

Serviceable: No

CIM Information: Prefix: PLAT and ID: 0131

SNMP Trap ID:

Automatically notify Support: No

User response: 1. Make sure the DIMM is installed correctly. 2. If the DIMM was disabled because of a memory fault (memory uncorrectable error or memory logging limit reached), follow the suggested actions for that error event and restart the server. 3. Check the IBM support website for an applicable retain tip or firmware update that applies to this memory event. If no memory fault is recorded in the logs and no DIMM connector error LED is lit, you can re-enable the DIMM through the Setup utility or the Advanced Settings Utility (ASU).

806f040c-2008xxxx [PhysicalMemoryElementName] Disabled on Subsystem [MemoryElementName]. (DIMM 8)

Explanation: This message is for the use case when an implementation has detected that Memory has been Disabled.

May also be shown as 806f040c2008xxxx or 0x806f040c2008xxxx

Severity: Info

Alert Category: System - Other

Serviceable: No

CIM Information: Prefix: PLAT and ID: 0131

SNMP Trap ID:

Automatically notify Support: No

User response: 1. Make sure the DIMM is installed correctly. 2. If the DIMM was disabled because of a memory fault (memory uncorrectable error or memory logging limit reached), follow the suggested actions for that error event and restart the server. 3. Check the IBM support website for an applicable retain tip or firmware update that applies to this memory event. If no memory fault is recorded in the logs and no DIMM connector error LED is lit, you can re-enable the DIMM through the Setup utility or the Advanced Settings Utility (ASU).

806f040c-2009xxxx [PhysicalMemoryElementName] Disabled on Subsystem [MemoryElementName]. (DIMM 9)

Explanation: This message is for the use case when an implementation has detected that Memory has been Disabled.

May also be shown as 806f040c2009xxxx or 0x806f040c2009xxxx

Severity: Info

Alert Category: System - Other

Serviceable: No

CIM Information: Prefix: PLAT and ID: 0131

SNMP Trap ID:

Automatically notify Support: No

User response: 1. Make sure the DIMM is installed correctly. 2. If the DIMM was disabled because of a memory fault (memory uncorrectable error or memory logging limit reached), follow the suggested actions for that error event and restart the server. 3. Check the IBM support website for an applicable retain tip or firmware update that applies

806f040c-200axxxx • 806f040c-200bxxxx

to this memory event. If no memory fault is recorded in the logs and no DIMM connector error LED is lit, you can re-enable the DIMM through the Setup utility or the Advanced Settings Utility (ASU).

806f040c-200axxxx [PhysicalMemoryElementName] Disabled on Subsystem [MemoryElementName]. (DIMM 10)

Explanation: This message is for the use case when an implementation has detected that Memory has been Disabled.

May also be shown as 806f040c200axxxx or 0x806f040c200axxxx

Severity: Info

Alert Category: System - Other

Serviceable: No

CIM Information: Prefix: PLAT and ID: 0131

SNMP Trap ID:

Automatically notify Support: No

User response: 1. Make sure the DIMM is installed correctly. 2. If the DIMM was disabled because of a memory fault (memory uncorrectable error or memory logging limit reached), follow the suggested actions for that error event and restart the server. 3. Check the IBM support website for an applicable retain tip or firmware update that applies to this memory event. If no memory fault is recorded in the logs and no DIMM connector error LED is lit, you can re-enable the DIMM through the Setup utility or the Advanced Settings Utility (ASU).

806f040c-200bxxxx [PhysicalMemoryElementName] Disabled on Subsystem [MemoryElementName]. (DIMM 11)

Explanation: This message is for the use case when an implementation has detected that Memory has been Disabled.

May also be shown as 806f040c200bxxxx or 0x806f040c200bxxxx

Severity: Info

Alert Category: System - Other

Serviceable: No

CIM Information: Prefix: PLAT and ID: 0131

SNMP Trap ID:

Automatically notify Support: No

User response: 1. Make sure the DIMM is installed correctly. 2. If the DIMM was disabled because of a memory fault (memory uncorrectable error or memory logging limit reached), follow the suggested actions for that error event and restart the server. 3. Check the IBM support website for an applicable retain tip or firmware update that applies to this memory event. If no memory fault is recorded in the logs and no DIMM connector error LED is lit, you can re-enable the DIMM through the Setup utility or the Advanced Settings Utility (ASU).

806f040c-200cxxxx [PhysicalMemoryElementName] Disabled on Subsystem [MemoryElementName]. (DIMM 12)

Explanation: This message is for the use case when an implementation has detected that Memory has been Disabled.

May also be shown as 806f040c200cxxxx or 0x806f040c200cxxxx

Severity: Info

Alert Category: System - Other

Serviceable: No

CIM Information: Prefix: PLAT and ID: 0131

SNMP Trap ID:

Automatically notify Support: No

User response: 1. Make sure the DIMM is installed correctly. 2. If the DIMM was disabled because of a memory fault (memory uncorrectable error or memory logging limit reached), follow the suggested actions for that error event and restart the server. 3. Check the IBM support website for an applicable retain tip or firmware update that applies to this memory event. If no memory fault is recorded in the logs and no DIMM connector error LED is lit, you can re-enable the DIMM through the Setup utility or the Advanced Settings Utility (ASU).

806f040c-200dxxxx [PhysicalMemoryElementName] Disabled on Subsystem [MemoryElementName]. (DIMM 13)

Explanation: This message is for the use case when an implementation has detected that Memory has been Disabled.

May also be shown as 806f040c200dxxxx or 0x806f040c200dxxxx

Severity: Info

Alert Category: System - Other

Serviceable: No

CIM Information: Prefix: PLAT and ID: 0131

SNMP Trap ID:

Automatically notify Support: No

User response: 1. Make sure the DIMM is installed correctly. 2. If the DIMM was disabled because of a memory fault (memory uncorrectable error or memory logging limit reached), follow the suggested actions for that error event and restart the server. 3. Check the IBM support website for an applicable retain tip or firmware update that applies to this memory event. If no memory fault is recorded in the logs and no DIMM connector error LED is lit, you can re-enable the DIMM through the Setup utility or the Advanced Settings Utility (ASU).

806f040c-200exxxx [PhysicalMemoryElementName] Disabled on Subsystem [MemoryElementName]. (DIMM 14)

Explanation: This message is for the use case when an implementation has detected that Memory has been Disabled.

May also be shown as 806f040c200exxxx or 0x806f040c200exxxx

Severity: Info

Alert Category: System - Other

Serviceable: No

CIM Information: Prefix: PLAT and ID: 0131

SNMP Trap ID:

Automatically notify Support: No

User response: 1. Make sure the DIMM is installed correctly. 2. If the DIMM was disabled because of a memory fault (memory uncorrectable error or memory logging limit reached), follow the suggested actions for that error event and restart the server. 3. Check the IBM support website for an applicable retain tip or firmware update that applies

806f040c-200fxxxx • 806f040c-2010xxxx

to this memory event. If no memory fault is recorded in the logs and no DIMM connector error LED is lit, you can re-enable the DIMM through the Setup utility or the Advanced Settings Utility (ASU).

806f040c-200fxxxx [PhysicalMemoryElementName] Disabled on Subsystem [MemoryElementName]. (DIMM 15)

Explanation: This message is for the use case when an implementation has detected that Memory has been Disabled.

May also be shown as 806f040c200fxxxx or 0x806f040c200fxxxx

Severity: Info

Alert Category: System - Other

Serviceable: No

CIM Information: Prefix: PLAT and ID: 0131

SNMP Trap ID:

Automatically notify Support: No

User response: 1. Make sure the DIMM is installed correctly. 2. If the DIMM was disabled because of a memory fault (memory uncorrectable error or memory logging limit reached), follow the suggested actions for that error event and restart the server. 3. Check the IBM support website for an applicable retain tip or firmware update that applies to this memory event. If no memory fault is recorded in the logs and no DIMM connector error LED is lit, you can re-enable the DIMM through the Setup utility or the Advanced Settings Utility (ASU).

806f040c-2010xxxx [PhysicalMemoryElementName] Disabled on Subsystem [MemoryElementName]. (DIMM 16)

Explanation: This message is for the use case when an implementation has detected that Memory has been Disabled.

May also be shown as 806f040c2010xxxx or 0x806f040c2010xxxx

Severity: Info

Alert Category: System - Other

Serviceable: No

CIM Information: Prefix: PLAT and ID: 0131

SNMP Trap ID:

Automatically notify Support: No

User response: 1. Make sure the DIMM is installed correctly. 2. If the DIMM was disabled because of a memory fault (memory uncorrectable error or memory logging limit reached), follow the suggested actions for that error event and restart the server. 3. Check the IBM support website for an applicable retain tip or firmware update that applies to this memory event. If no memory fault is recorded in the logs and no DIMM connector error LED is lit, you can re-enable the DIMM through the Setup utility or the Advanced Settings Utility (ASU).

806f040c-2011xxxx [PhysicalMemoryElementName] Disabled on Subsystem [MemoryElementName]. (DIMM 17)

Explanation: This message is for the use case when an implementation has detected that Memory has been Disabled.

May also be shown as 806f040c2011xxxx or 0x806f040c2011xxxx

Severity: Info

Alert Category: System - Other

Serviceable: No

CIM Information: Prefix: PLAT and ID: 0131

SNMP Trap ID:

Automatically notify Support: No

User response: 1. Make sure the DIMM is installed correctly. 2. If the DIMM was disabled because of a memory fault (memory uncorrectable error or memory logging limit reached), follow the suggested actions for that error event and restart the server. 3. Check the IBM support website for an applicable retain tip or firmware update that applies to this memory event. If no memory fault is recorded in the logs and no DIMM connector error LED is lit, you can re-enable the DIMM through the Setup utility or the Advanced Settings Utility (ASU).

806f040c-2012xxxx [PhysicalMemoryElementName] Disabled on Subsystem [MemoryElementName]. (DIMM 18)

Explanation: This message is for the use case when an implementation has detected that Memory has been Disabled.

May also be shown as 806f040c2012xxxx or 0x806f040c2012xxxx

Severity: Info

Alert Category: System - Other

Serviceable: No

CIM Information: Prefix: PLAT and ID: 0131

SNMP Trap ID:

Automatically notify Support: No

User response: 1. Make sure the DIMM is installed correctly. 2. If the DIMM was disabled because of a memory fault (memory uncorrectable error or memory logging limit reached), follow the suggested actions for that error event and restart the server. 3. Check the IBM support website for an applicable retain tip or firmware update that applies to this memory event. If no memory fault is recorded in the logs and no DIMM connector error LED is lit, you can re-enable the DIMM through the Setup utility or the Advanced Settings Utility (ASU).

806f040c-2581xxxx [PhysicalMemoryElementName] Disabled on Subsystem [MemoryElementName]. (All DIMMS)

Explanation: This message is for the use case when an implementation has detected that Memory has been Disabled.

May also be shown as 806f040c2581xxxx or 0x806f040c2581xxxx

Severity: Info

Alert Category: System - Other

Serviceable: No

CIM Information: Prefix: PLAT and ID: 0131

SNMP Trap ID:

Automatically notify Support: No

User response: 1. Make sure the DIMM is installed correctly. 2. If the DIMM was disabled because of a memory fault (memory uncorrectable error or memory logging limit reached), follow the suggested actions for that error event

806f0413-2582xxxx • 806f0507-0301xxxx

and restart the server. 3. Check the IBM support website for an applicable retain tip or firmware update that applies to this memory event. If no memory fault is recorded in the logs and no DIMM connector error LED is lit, you can re-enable the DIMM through the Setup utility or the Advanced Settings Utility (ASU). One of the DIMMs :

806f0413-2582xxxx A PCI PERR has occurred on system [ComputerSystemElementName]. (PCIs)

Explanation: This message is for the use case when an implementation has detected a PCI PERR.

May also be shown as 806f04132582xxxx or 0x806f04132582xxxx

Severity: Error

Alert Category: Critical - Other

Serviceable: Yes

CIM Information: Prefix: PLAT and ID: 0232

SNMP Trap ID: 50

Automatically notify Support: No

User response: 1. Check the PCI LED. 2. Reseat the affected adapters and riser cards. 3. Update the server firmware (UEFI and IMM) and adapter firmware. Important: Some cluster solutions require specific code levels or coordinated code updates. If the device is part of a cluster solution, verify that the latest level of code is supported for the cluster solution before you update the code. 4. Remove both adapters. 5. Replace the PCIe adapters. 6. Replace the riser cards.

806f0507-0301xxxx [ProcessorElementName] has a Configuration Mismatch. (CPU 1)

Explanation: This message is for the use case when an implementation has detected a Processor Configuration Mismatch has occurred.

May also be shown as 806f05070301xxxx or 0x806f05070301xxxx

Severity: Error

Alert Category: Critical - CPU

Serviceable: Yes

CIM Information: Prefix: PLAT and ID: 0062

SNMP Trap ID: 40

Automatically notify Support: No

User response: 1. Check the CPU LED. See more information about the CPU LED in Light path diagnostics. 2. Check for a server firmware update. Important: Some cluster solutions require specific code levels or coordinated code updates. If the device is part of a cluster solution, verify that the latest level of code is supported for the cluster solution before you update the code. 3. Make sure that the installed microprocessors are compatible with each other. 4. (Trained technician only) Reseat microprocessor n. 5. (Trained technician only) Replace microprocessor n. (n = microprocessor number)

806f0507-0302xxxx [ProcessorElementName] has a Configuration Mismatch. (CPU 2)

Explanation: This message is for the use case when an implementation has detected a Processor Configuration Mismatch has occurred.

May also be shown as 806f05070302xxxx or 0x806f05070302xxxx

Severity: Error

Alert Category: Critical - CPU

Serviceable: Yes

CIM Information: Prefix: PLAT and ID: 0062

SNMP Trap ID: 40

Automatically notify Support: No

User response: 1. Check the CPU LED. See more information about the CPU LED in Light path diagnostics. 2. Check for a server firmware update. Important: Some cluster solutions require specific code levels or coordinated code updates. If the device is part of a cluster solution, verify that the latest level of code is supported for the cluster solution before you update the code. 3. Make sure that the installed microprocessors are compatible with each other. 4. (Trained technician only) Reseat microprocessor n. 5. (Trained technician only) Replace microprocessor n. (n = microprocessor number)

806f050c-2001xxxx Memory Logging Limit Reached for [PhysicalMemoryElementName] on Subsystem [MemoryElementName]. (DIMM 1)

Explanation: This message is for the use case when an implementation has detected that the Memory Logging Limit has been Reached.

May also be shown as 806f050c2001xxxx or 0x806f050c2001xxxx

Severity: Warning

Alert Category: Warning - Memory

Serviceable: Yes

CIM Information: Prefix: PLAT and ID: 0144

SNMP Trap ID: 43

Automatically notify Support: Yes

User response: 1. Check the IBM support website for an applicable retain tip or firmware update that applies to this memory error. 2. Swap the affected DIMMs (as indicated by the error LEDs on the system board or the event logs) to a different memory channel or microprocessor. 3. If the error still occurs on the same DIMM, replace the affected DIMM. 4. (Trained technician only) If the problem occurs on the same DIMM connector, check the DIMM connector. If the connector contains any foreign material or is damaged, replace the system board. 5. (Trained technician only) Remove the affected microprocessor and check the microprocessor socket pins for any damaged pins. If a damage is found, replace the system board. 6. (Trained technician only) Replace the affected microprocessor.

806f050c-2002xxxx Memory Logging Limit Reached for [PhysicalMemoryElementName] on Subsystem [MemoryElementName]. (DIMM 2)

Explanation: This message is for the use case when an implementation has detected that the Memory Logging Limit has been Reached.

May also be shown as 806f050c2002xxxx or 0x806f050c2002xxxx

Severity: Warning

Alert Category: Warning - Memory

Serviceable: Yes

CIM Information: Prefix: PLAT and **ID:** 0144

SNMP Trap ID: 43

Automatically notify Support: Yes

User response: 1. Check the IBM support website for an applicable retain tip or firmware update that applies to this memory error. 2. Swap the affected DIMMs (as indicated by the error LEDs on the system board or the event logs) to a different memory channel or microprocessor. 3. If the error still occurs on the same DIMM, replace the affected DIMM. 4. (Trained technician only) If the problem occurs on the same DIMM connector, check the DIMM connector. If the connector contains any foreign material or is damaged, replace the system board. 5. (Trained technician only) Remove the affected microprocessor and check the microprocessor socket pins for any damaged pins. If a damage is found, replace the system board. 6. (Trained technician only) Replace the affected microprocessor.

806f050c-2003xxxx Memory Logging Limit Reached for [PhysicalMemoryElementName] on Subsystem [MemoryElementName]. (DIMM 3)

Explanation: This message is for the use case when an implementation has detected that the Memory Logging Limit has been Reached.

May also be shown as 806f050c2003xxxx or 0x806f050c2003xxxx

Severity: Warning

Alert Category: Warning - Memory

Serviceable: Yes

CIM Information: Prefix: PLAT and **ID:** 0144

SNMP Trap ID: 43

Automatically notify Support: Yes

User response: 1. Check the IBM support website for an applicable retain tip or firmware update that applies to this memory error. 2. Swap the affected DIMMs (as indicated by the error LEDs on the system board or the event logs) to a different memory channel or microprocessor. 3. If the error still occurs on the same DIMM, replace the affected DIMM. 4. (Trained technician only) If the problem occurs on the same DIMM connector, check the DIMM connector. If the connector contains any foreign material or is damaged, replace the system board. 5. (Trained technician only) Remove the affected microprocessor and check the microprocessor socket pins for any damaged pins. If a damage is found, replace the system board. 6. (Trained technician only) Replace the affected microprocessor.

806f050c-2004xxxx Memory Logging Limit Reached for [PhysicalMemoryElementName] on Subsystem [MemoryElementName]. (DIMM 4)

Explanation: This message is for the use case when an implementation has detected that the Memory Logging Limit has been Reached.

May also be shown as 806f050c2004xxxx or 0x806f050c2004xxxx

Severity: Warning

Alert Category: Warning - Memory

Serviceable: Yes

CIM Information: Prefix: PLAT and ID: 0144

SNMP Trap ID: 43

Automatically notify Support: Yes

User response: 1. Check the IBM support website for an applicable retain tip or firmware update that applies to this memory error. 2. Swap the affected DIMMs (as indicated by the error LEDs on the system board or the event logs) to a different memory channel or microprocessor. 3. If the error still occurs on the same DIMM, replace the affected DIMM. 4. (Trained technician only) If the problem occurs on the same DIMM connector, check the DIMM connector. If the connector contains any foreign material or is damaged, replace the system board. 5. (Trained technician only) Remove the affected microprocessor and check the microprocessor socket pins for any damaged pins. If a damage is found, replace the system board. 6. (Trained technician only) Replace the affected microprocessor.

806f050c-2005xxxx Memory Logging Limit Reached for [PhysicalMemoryElementName] on Subsystem [MemoryElementName]. (DIMM 5)

Explanation: This message is for the use case when an implementation has detected that the Memory Logging Limit has been Reached.

May also be shown as 806f050c2005xxxx or 0x806f050c2005xxxx

Severity: Warning

Alert Category: Warning - Memory

Serviceable: Yes

CIM Information: Prefix: PLAT and ID: 0144

SNMP Trap ID: 43

Automatically notify Support: Yes

User response: 1. Check the IBM support website for an applicable retain tip or firmware update that applies to this memory error. 2. Swap the affected DIMMs (as indicated by the error LEDs on the system board or the event logs) to a different memory channel or microprocessor. 3. If the error still occurs on the same DIMM, replace the affected DIMM. 4. (Trained technician only) If the problem occurs on the same DIMM connector, check the DIMM connector. If the connector contains any foreign material or is damaged, replace the system board. 5. (Trained technician only) Remove the affected microprocessor and check the microprocessor socket pins for any damaged pins. If a damage is found, replace the system board. 6. (Trained technician only) Replace the affected microprocessor.

806f050c-2006xxxx Memory Logging Limit Reached for [PhysicalMemoryElementName] on Subsystem [MemoryElementName]. (DIMM 6)

Explanation: This message is for the use case when an implementation has detected that the Memory Logging Limit has been Reached.

May also be shown as 806f050c2006xxxx or 0x806f050c2006xxxx

Severity: Warning

Alert Category: Warning - Memory

Serviceable: Yes

CIM Information: Prefix: PLAT and ID: 0144

SNMP Trap ID: 43

Automatically notify Support: Yes

User response: 1. Check the IBM support website for an applicable retain tip or firmware update that applies to this memory error. 2. Swap the affected DIMMs (as indicated by the error LEDs on the system board or the event logs) to a different memory channel or microprocessor. 3. If the error still occurs on the same DIMM, replace the affected DIMM. 4. (Trained technician only) If the problem occurs on the same DIMM connector, check the DIMM connector. If the connector contains any foreign material or is damaged, replace the system board. 5. (Trained technician only) Remove the affected microprocessor and check the microprocessor socket pins for any damaged pins. If a damage is found, replace the system board. 6. (Trained technician only) Replace the affected microprocessor.

806f050c-2007xxxx Memory Logging Limit Reached for [PhysicalMemoryElementName] on Subsystem [MemoryElementName]. (DIMM 7)

Explanation: This message is for the use case when an implementation has detected that the Memory Logging Limit has been Reached.

May also be shown as 806f050c2007xxxx or 0x806f050c2007xxxx

Severity: Warning

Alert Category: Warning - Memory

Serviceable: Yes

CIM Information: Prefix: PLAT and ID: 0144

SNMP Trap ID: 43

Automatically notify Support: Yes

User response: 1. Check the IBM support website for an applicable retain tip or firmware update that applies to this memory error. 2. Swap the affected DIMMs (as indicated by the error LEDs on the system board or the event logs) to a different memory channel or microprocessor. 3. If the error still occurs on the same DIMM, replace the affected DIMM. 4. (Trained technician only) If the problem occurs on the same DIMM connector, check the DIMM connector. If the connector contains any foreign material or is damaged, replace the system board. 5. (Trained technician only) Remove the affected microprocessor and check the microprocessor socket pins for any damaged pins. If a damage is found, replace the system board. 6. (Trained technician only) Replace the affected microprocessor.

806f050c-2008xxxx Memory Logging Limit Reached for [PhysicalMemoryElementName] on Subsystem [MemoryElementName]. (DIMM 8)

Explanation: This message is for the use case when an implementation has detected that the Memory Logging Limit has been Reached.

May also be shown as 806f050c2008xxxx or 0x806f050c2008xxxx

Severity: Warning

Alert Category: Warning - Memory

Serviceable: Yes

CIM Information: Prefix: PLAT and ID: 0144

SNMP Trap ID: 43

Automatically notify Support: Yes

User response: 1. Check the IBM support website for an applicable retain tip or firmware update that applies to this memory error. 2. Swap the affected DIMMs (as indicated by the error LEDs on the system board or the event logs) to a different memory channel or microprocessor. 3. If the error still occurs on the same DIMM, replace the affected DIMM. 4. (Trained technician only) If the problem occurs on the same DIMM connector, check the DIMM connector. If the connector contains any foreign material or is damaged, replace the system board. 5. (Trained technician only) Remove the affected microprocessor and check the microprocessor socket pins for any damaged pins. If a damage is found, replace the system board. 6. (Trained technician only) Replace the affected microprocessor.

806f050c-2009xxxx Memory Logging Limit Reached for [PhysicalMemoryElementName] on Subsystem [MemoryElementName]. (DIMM 9)

Explanation: This message is for the use case when an implementation has detected that the Memory Logging Limit has been Reached.

May also be shown as 806f050c2009xxxx or 0x806f050c2009xxxx

Severity: Warning

Alert Category: Warning - Memory

Serviceable: Yes

CIM Information: Prefix: PLAT and ID: 0144

SNMP Trap ID: 43

Automatically notify Support: Yes

User response: 1. Check the IBM support website for an applicable retain tip or firmware update that applies to this memory error. 2. Swap the affected DIMMs (as indicated by the error LEDs on the system board or the event logs) to a different memory channel or microprocessor. 3. If the error still occurs on the same DIMM, replace the affected DIMM. 4. (Trained technician only) If the problem occurs on the same DIMM connector, check the DIMM connector. If the connector contains any foreign material or is damaged, replace the system board. 5. (Trained technician only) Remove the affected microprocessor and check the microprocessor socket pins for any damaged pins. If a damage is found, replace the system board. 6. (Trained technician only) Replace the affected microprocessor.

806f050c-200axxxx Memory Logging Limit Reached for [PhysicalMemoryElementName] on Subsystem [MemoryElementName]. (DIMM 10)

Explanation: This message is for the use case when an implementation has detected that the Memory Logging Limit has been Reached.

May also be shown as 806f050c200axxxx or 0x806f050c200axxxx

Severity: Warning

Alert Category: Warning - Memory

Serviceable: Yes

CIM Information: Prefix: PLAT and ID: 0144

SNMP Trap ID: 43

Automatically notify Support: Yes

User response: 1. Check the IBM support website for an applicable retain tip or firmware update that applies to this memory error. 2. Swap the affected DIMMs (as indicated by the error LEDs on the system board or the event logs) to a different memory channel or microprocessor. 3. If the error still occurs on the same DIMM, replace the affected DIMM. 4. (Trained technician only) If the problem occurs on the same DIMM connector, check the DIMM connector. If the connector contains any foreign material or is damaged, replace the system board. 5. (Trained technician only) Remove the affected microprocessor and check the microprocessor socket pins for any damaged pins. If a damage is found, replace the system board. 6. (Trained technician only) Replace the affected microprocessor.

806f050c-200bxxxx Memory Logging Limit Reached for [PhysicalMemoryElementName] on Subsystem [MemoryElementName]. (DIMM 11)

Explanation: This message is for the use case when an implementation has detected that the Memory Logging Limit has been Reached.

May also be shown as 806f050c200bxxxx or 0x806f050c200bxxxx

Severity: Warning

Alert Category: Warning - Memory

Serviceable: Yes

CIM Information: Prefix: PLAT and ID: 0144

SNMP Trap ID: 43

Automatically notify Support: Yes

User response: 1. Check the IBM support website for an applicable retain tip or firmware update that applies to this memory error. 2. Swap the affected DIMMs (as indicated by the error LEDs on the system board or the event logs) to a different memory channel or microprocessor. 3. If the error still occurs on the same DIMM, replace the affected DIMM. 4. (Trained technician only) If the problem occurs on the same DIMM connector, check the DIMM connector. If the connector contains any foreign material or is damaged, replace the system board. 5. (Trained technician only) Remove the affected microprocessor and check the microprocessor socket pins for any damaged pins. If a damage is found, replace the system board. 6. (Trained technician only) Replace the affected microprocessor.

806f050c-200cxxxx Memory Logging Limit Reached for [PhysicalMemoryElementName] on Subsystem [MemoryElementName]. (DIMM 12)

Explanation: This message is for the use case when an implementation has detected that the Memory Logging Limit has been Reached.

May also be shown as 806f050c200cxxxx or 0x806f050c200cxxxx

Severity: Warning

Alert Category: Warning - Memory

Serviceable: Yes

CIM Information: Prefix: PLAT and ID: 0144

SNMP Trap ID: 43

Automatically notify Support: Yes

User response: 1. Check the IBM support website for an applicable retain tip or firmware update that applies to this memory error. 2. Swap the affected DIMMs (as indicated by the error LEDs on the system board or the event logs) to a different memory channel or microprocessor. 3. If the error still occurs on the same DIMM, replace the affected DIMM. 4. (Trained technician only) If the problem occurs on the same DIMM connector, check the DIMM connector. If the connector contains any foreign material or is damaged, replace the system board. 5. (Trained technician only) Remove the affected microprocessor and check the microprocessor socket pins for any damaged pins. If a damage is found, replace the system board. 6. (Trained technician only) Replace the affected microprocessor.

806f050c-200dxxxx Memory Logging Limit Reached for [PhysicalMemoryElementName] on Subsystem [MemoryElementName]. (DIMM 13)

Explanation: This message is for the use case when an implementation has detected that the Memory Logging Limit has been Reached.

May also be shown as 806f050c200dxxxx or 0x806f050c200dxxxx

Severity: Warning

Alert Category: Warning - Memory

Serviceable: Yes

CIM Information: Prefix: PLAT and ID: 0144

SNMP Trap ID: 43

Automatically notify Support: Yes

User response: 1. Check the IBM support website for an applicable retain tip or firmware update that applies to this memory error. 2. Swap the affected DIMMs (as indicated by the error LEDs on the system board or the event logs) to a different memory channel or microprocessor. 3. If the error still occurs on the same DIMM, replace the affected DIMM. 4. (Trained technician only) If the problem occurs on the same DIMM connector, check the DIMM connector. If the connector contains any foreign material or is damaged, replace the system board. 5. (Trained technician only) Remove the affected microprocessor and check the microprocessor socket pins for any damaged pins. If a damage is found, replace the system board. 6. (Trained technician only) Replace the affected microprocessor.

806f050c-200exxxx Memory Logging Limit Reached for [PhysicalMemoryElementName] on Subsystem [MemoryElementName]. (DIMM 14)

Explanation: This message is for the use case when an implementation has detected that the Memory Logging Limit has been Reached.

May also be shown as 806f050c200exxxx or 0x806f050c200exxxx

Severity: Warning

Alert Category: Warning - Memory

Serviceable: Yes

CIM Information: Prefix: PLAT and ID: 0144

SNMP Trap ID: 43

Automatically notify Support: Yes

User response: 1. Check the IBM support website for an applicable retain tip or firmware update that applies to this memory error. 2. Swap the affected DIMMs (as indicated by the error LEDs on the system board or the event logs) to a different memory channel or microprocessor. 3. If the error still occurs on the same DIMM, replace the affected DIMM. 4. (Trained technician only) If the problem occurs on the same DIMM connector, check the DIMM connector. If the connector contains any foreign material or is damaged, replace the system board. 5. (Trained technician only) Remove the affected microprocessor and check the microprocessor socket pins for any damaged pins. If a damage is found, replace the system board. 6. (Trained technician only) Replace the affected microprocessor.

806f050c-200fxxxx Memory Logging Limit Reached for [PhysicalMemoryElementName] on Subsystem [MemoryElementName]. (DIMM 15)

Explanation: This message is for the use case when an implementation has detected that the Memory Logging Limit has been Reached.

May also be shown as 806f050c200fxxxx or 0x806f050c200fxxxx

Severity: Warning

Alert Category: Warning - Memory

Serviceable: Yes

CIM Information: Prefix: PLAT and ID: 0144

SNMP Trap ID: 43

Automatically notify Support: Yes

User response: 1. Check the IBM support website for an applicable retain tip or firmware update that applies to this memory error. 2. Swap the affected DIMMs (as indicated by the error LEDs on the system board or the event logs) to a different memory channel or microprocessor. 3. If the error still occurs on the same DIMM, replace the affected DIMM. 4. (Trained technician only) If the problem occurs on the same DIMM connector, check the DIMM connector. If the connector contains any foreign material or is damaged, replace the system board. 5. (Trained technician only) Remove the affected microprocessor and check the microprocessor socket pins for any damaged pins. If a damage is found, replace the system board. 6. (Trained technician only) Replace the affected microprocessor.

806f050c-2010xxxx Memory Logging Limit Reached for [PhysicalMemoryElementName] on Subsystem [MemoryElementName]. (DIMM 16)

Explanation: This message is for the use case when an implementation has detected that the Memory Logging Limit has been Reached.

May also be shown as 806f050c2010xxxx or 0x806f050c2010xxxx

Severity: Warning

Alert Category: Warning - Memory

Serviceable: Yes

CIM Information: Prefix: PLAT and ID: 0144

SNMP Trap ID: 43

Automatically notify Support: Yes

User response: 1. Check the IBM support website for an applicable retain tip or firmware update that applies to this memory error. 2. Swap the affected DIMMs (as indicated by the error LEDs on the system board or the event logs) to a different memory channel or microprocessor. 3. If the error still occurs on the same DIMM, replace the affected DIMM. 4. (Trained technician only) If the problem occurs on the same DIMM connector, check the DIMM connector. If the connector contains any foreign material or is damaged, replace the system board. 5. (Trained technician only) Remove the affected microprocessor and check the microprocessor socket pins for any damaged pins. If a damage is found, replace the system board. 6. (Trained technician only) Replace the affected microprocessor.

806f050c-2011xxxx Memory Logging Limit Reached for [PhysicalMemoryElementName] on Subsystem [MemoryElementName]. (DIMM 17)

Explanation: This message is for the use case when an implementation has detected that the Memory Logging Limit has been Reached.

May also be shown as 806f050c2011xxxx or 0x806f050c2011xxxx

Severity: Warning

Alert Category: Warning - Memory

Serviceable: Yes

CIM Information: Prefix: PLAT and ID: 0144

SNMP Trap ID: 43

Automatically notify Support: Yes

User response: 1. Check the IBM support website for an applicable retain tip or firmware update that applies to this memory error. 2. Swap the affected DIMMs (as indicated by the error LEDs on the system board or the event logs) to a different memory channel or microprocessor. 3. If the error still occurs on the same DIMM, replace the affected DIMM. 4. (Trained technician only) If the problem occurs on the same DIMM connector, check the DIMM connector. If the connector contains any foreign material or is damaged, replace the system board. 5. (Trained technician only) Remove the affected microprocessor and check the microprocessor socket pins for any damaged pins. If a damage is found, replace the system board. 6. (Trained technician only) Replace the affected microprocessor.

806f050c-2012xxxx Memory Logging Limit Reached for [PhysicalMemoryElementName] on Subsystem [MemoryElementName]. (DIMM 18)

Explanation: This message is for the use case when an implementation has detected that the Memory Logging Limit has been Reached.

May also be shown as 806f050c2012xxxx or 0x806f050c2012xxxx

Severity: Warning

Alert Category: Warning - Memory

Serviceable: Yes

CIM Information: Prefix: PLAT and ID: 0144

SNMP Trap ID: 43

Automatically notify Support: Yes

User response: 1. Check the IBM support website for an applicable retain tip or firmware update that applies to this memory error. 2. Swap the affected DIMMs (as indicated by the error LEDs on the system board or the event logs) to a different memory channel or microprocessor. 3. If the error still occurs on the same DIMM, replace the affected DIMM. 4. (Trained technician only) If the problem occurs on the same DIMM connector, check the DIMM connector. If the connector contains any foreign material or is damaged, replace the system board. 5. (Trained technician only) Remove the affected microprocessor and check the microprocessor socket pins for any damaged pins. If a damage is found, replace the system board. 6. (Trained technician only) Replace the affected microprocessor.

806f050c-2581xxxx Memory Logging Limit Reached for [PhysicalMemoryElementName] on Subsystem [MemoryElementName]. (All DIMMs)

Explanation: This message is for the use case when an implementation has detected that the Memory Logging Limit has been Reached.

May also be shown as 806f050c2581xxxx or 0x806f050c2581xxxx

Severity: Warning

Alert Category: Warning - Memory

Serviceable: Yes

CIM Information: Prefix: PLAT and ID: 0144

SNMP Trap ID: 43

Automatically notify Support: Yes

User response: 1. Check the IBM support website for an applicable retain tip or firmware update that applies to this memory error. 2. Swap the affected DIMMs (as indicated by the error LEDs on the system board or the event logs) to a different memory channel or microprocessor. 3. If the error still occurs on the same DIMM, replace the affected DIMM. 4. (Trained technician only) If the problem occurs on the same DIMM connector, check the DIMM connector. If the connector contains any foreign material or is damaged, replace the system board. 5. (Trained technician only) Remove the affected microprocessor and check the microprocessor socket pins for any damaged pins. If a damage is found, replace the system board. 6. (Trained technician only) Replace the affected microprocessor. One of the DIMMs :

806f050d-0400xxxx Array [ComputerSystemElementName] is in critical condition. (Drive 0)

Explanation: This message is for the use case when an implementation has detected that an Array is Critical.

May also be shown as 806f050d0400xxxx or 0x806f050d0400xxxx

Severity: Error

Alert Category: Critical - Hard Disk drive

Serviceable: Yes

CIM Information: Prefix: PLAT and ID: 0174

SNMP Trap ID: 5

Automatically notify Support: No

User response: 1. Make sure that the RAID adapter firmware and hard disk drive firmware is at the latest level. 2. Make sure that the SAS cable is connected correctly. 3. Replace the SAS cable. 4. Replace the RAID adapter. 5. Replace the hard disk drive that is indicated by a lit status LED.

806f050d-0401xxxx Array [ComputerSystemElementName] is in critical condition. (Drive 1)

Explanation: This message is for the use case when an implementation has detected that an Array is Critical.

May also be shown as 806f050d0401xxxx or 0x806f050d0401xxxx

Severity: Error

Alert Category: Critical - Hard Disk drive

Serviceable: Yes

CIM Information: Prefix: PLAT and ID: 0174

SNMP Trap ID: 5

Automatically notify Support: No

User response: 1. Make sure that the RAID adapter firmware and hard disk drive firmware is at the latest level. 2. Make sure that the SAS cable is connected correctly. 3. Replace the SAS cable. 4. Replace the RAID adapter. 5. Replace the hard disk drive that is indicated by a lit status LED.

806f050d-0402xxxx Array [ComputerSystemElementName] is in critical condition. (Drive 2)

Explanation: This message is for the use case when an implementation has detected that an Array is Critical.

May also be shown as 806f050d0402xxxx or 0x806f050d0402xxxx

Severity: Error

Alert Category: Critical - Hard Disk drive

Serviceable: Yes

CIM Information: Prefix: PLAT and ID: 0174

SNMP Trap ID: 5

Automatically notify Support: No

User response: 1. Make sure that the RAID adapter firmware and hard disk drive firmware is at the latest level. 2. Make sure that the SAS cable is connected correctly. 3. Replace the SAS cable. 4. Replace the RAID adapter. 5. Replace the hard disk drive that is indicated by a lit status LED.

806f050d-0403xxxx • 806f050d-0405xxxx

806f050d-0403xxxx Array [ComputerSystemElementName] is in critical condition. (Drive 3)

Explanation: This message is for the use case when an implementation has detected that an Array is Critical.

May also be shown as 806f050d0403xxxx or 0x806f050d0403xxxx

Severity: Error

Alert Category: Critical - Hard Disk drive

Serviceable: Yes

CIM Information: Prefix: PLAT and ID: 0174

SNMP Trap ID: 5

Automatically notify Support: No

User response: 1. Make sure that the RAID adapter firmware and hard disk drive firmware is at the latest level. 2. Make sure that the SAS cable is connected correctly. 3. Replace the SAS cable. 4. Replace the RAID adapter. 5. Replace the hard disk drive that is indicated by a lit status LED.

806f050d-0404xxxx Array [ComputerSystemElementName] is in critical condition. (Drive 4)

Explanation: This message is for the use case when an implementation has detected that an Array is Critical.

May also be shown as 806f050d0404xxxx or 0x806f050d0404xxxx

Severity: Error

Alert Category: Critical - Hard Disk drive

Serviceable: Yes

CIM Information: Prefix: PLAT and ID: 0174

SNMP Trap ID: 5

Automatically notify Support: No

User response: 1. Make sure that the RAID adapter firmware and hard disk drive firmware is at the latest level. 2. Make sure that the SAS cable is connected correctly. 3. Replace the SAS cable. 4. Replace the RAID adapter. 5. Replace the hard disk drive that is indicated by a lit status LED.

806f050d-0405xxxx Array [ComputerSystemElementName] is in critical condition. (Drive 5)

Explanation: This message is for the use case when an implementation has detected that an Array is Critical.

May also be shown as 806f050d0405xxxx or 0x806f050d0405xxxx

Severity: Error

Alert Category: Critical - Hard Disk drive

Serviceable: Yes

CIM Information: Prefix: PLAT and ID: 0174

SNMP Trap ID: 5

Automatically notify Support: No

User response: 1. Make sure that the RAID adapter firmware and hard disk drive firmware is at the latest level. 2. Make sure that the SAS cable is connected correctly. 3. Replace the SAS cable. 4. Replace the RAID adapter. 5. Replace the hard disk drive that is indicated by a lit status LED.

806f050d-0406xxxx Array [ComputerSystemElementName] is in critical condition. (Drive 6)

Explanation: This message is for the use case when an implementation has detected that an Array is Critical.

May also be shown as 806f050d0406xxxx or 0x806f050d0406xxxx

Severity: Error

Alert Category: Critical - Hard Disk drive

Serviceable: Yes

CIM Information: Prefix: PLAT and ID: 0174

SNMP Trap ID: 5

Automatically notify Support: No

User response: 1. Make sure that the RAID adapter firmware and hard disk drive firmware is at the latest level. 2. Make sure that the SAS cable is connected correctly. 3. Replace the SAS cable. 4. Replace the RAID adapter. 5. Replace the hard disk drive that is indicated by a lit status LED.

806f050d-0407xxxx Array [ComputerSystemElementName] is in critical condition. (Drive 7)

Explanation: This message is for the use case when an implementation has detected that an Array is Critical.

May also be shown as 806f050d0407xxxx or 0x806f050d0407xxxx

Severity: Error

Alert Category: Critical - Hard Disk drive

Serviceable: Yes

CIM Information: Prefix: PLAT and ID: 0174

SNMP Trap ID: 5

Automatically notify Support: No

User response: 1. Make sure that the RAID adapter firmware and hard disk drive firmware is at the latest level. 2. Make sure that the SAS cable is connected correctly. 3. Replace the SAS cable. 4. Replace the RAID adapter. 5. Replace the hard disk drive that is indicated by a lit status LED.

806f0513-2582xxxx A PCI SERR has occurred on system [ComputerSystemElementName]. (PCIs)

Explanation: This message is for the use case when an implementation has detected a PCI SERR.

May also be shown as 806f05132582xxxx or 0x806f05132582xxxx

Severity: Error

Alert Category: Critical - Other

Serviceable: Yes

CIM Information: Prefix: PLAT and ID: 0234

SNMP Trap ID: 50

Automatically notify Support: No

User response: 1. Check the PCI LED. 2. Reseat the affected adapters and riser card. 3. Update the server firmware (UEFI and IMM) and adapter firmware. Important: Some cluster solutions require specific code levels or coordinated code updates. If the device is part of a cluster solution, verify that the latest level of code is supported for the cluster solution before you update the code. 4. Make sure that the adapter is supported. For a list of supported optional devices, see <http://www.ibm.com/systems/info/x86servers/serverproven/compat/us/>. 5. Remove both adapters. 6. Replace the PCIe adapters. 7. Replace the riser cards.

**806f052b-2101xxxx Invalid or Unsupported firmware or software was detected on system
[ComputerSystemElementName]. (IMM FW Failover)**

Explanation: This message is for the use case when an implementation has detected an Invalid/Unsupported Firmware/Software Version.

May also be shown as 806f052b2101xxxx or 0x806f052b2101xxxx

Severity: Error

Alert Category: Critical - Other

Serviceable: Yes

CIM Information: Prefix: PLAT and ID: 0446

SNMP Trap ID: 50

Automatically notify Support: No

User response: 1. Make sure the server meets the minimum configuration to start (see Power-supply LEDs). 2. Recover the server firmware from the backup page by restarting the server. 3. Update the server firmware to the latest level (see Updating the firmware). Important: Some cluster solutions require specific code levels or coordinated code updates. If the device is part of a cluster solution, verify that the latest level of code is supported for the cluster solution before you update the code. 4. Remove components one at a time, restarting the server each time, to see if the problem goes away. 5. If the problem remains, (trained service technician) replace the system board.

**806f0607-0301xxxx An SM BIOS Uncorrectable CPU complex error for [ProcessorElementName] has asserted.
(CPU 1)**

Explanation: This message is for the use case when an SM BIOS Uncorrectable CPU complex error has asserted.

May also be shown as 806f06070301xxxx or 0x806f06070301xxxx

Severity: Error

Alert Category: Critical - CPU

Serviceable: Yes

CIM Information: Prefix: PLAT and ID: 0816

SNMP Trap ID: 40

Automatically notify Support: No

User response: 1. Make sure that the installed microprocessors are compatible with each other (see Installing a microprocessor and heat sink for information about microprocessor requirements). 2. Update the server firmware to the latest level (see Updating the firmware). 3. (Trained technician only) Replace the incompatible microprocessor.

**806f0607-0302xxxx An SM BIOS Uncorrectable CPU complex error for [ProcessorElementName] has asserted.
(CPU 2)**

Explanation: This message is for the use case when an SM BIOS Uncorrectable CPU complex error has asserted.

May also be shown as 806f06070302xxxx or 0x806f06070302xxxx

Severity: Error

Alert Category: Critical - CPU

Serviceable: Yes

CIM Information: Prefix: PLAT and ID: 0816

SNMP Trap ID: 40

Automatically notify Support: No

User response: 1. Make sure that the installed microprocessors are compatible with each other (see Installing a microprocessor and heat sink for information about microprocessor requirements). 2. Update the server firmware to the latest level (see Updating the firmware). 3. (Trained technician only) Replace the incompatible microprocessor.

806f0608-0a01xxxx [PowerSupplyElementName] has a Configuration Mismatch. (Power Supply 1)

Explanation: This message is for the use case when an implementation has detected a Power Supply with a Configuration Error.

May also be shown as 806f06080a01xxxx or 0x806f06080a01xxxx

Severity: Error

Alert Category: Critical - Power

Serviceable: Yes

CIM Information: Prefix: PLAT and ID: 0104

SNMP Trap ID: 4

Automatically notify Support: No

User response: 1. Make sure that the power supplies installed are with the same rating or wattage. 2. Reinstall the power supplies with the same rating or wattage.

806f0608-0a02xxxx [PowerSupplyElementName] has a Configuration Mismatch. (Power Supply 2)

Explanation: This message is for the use case when an implementation has detected a Power Supply with a Configuration Error.

May also be shown as 806f06080a02xxxx or 0x806f06080a02xxxx

Severity: Error

Alert Category: Critical - Power

Serviceable: Yes

CIM Information: Prefix: PLAT and ID: 0104

SNMP Trap ID: 4

Automatically notify Support: No

User response: 1. Make sure that the power supplies installed are with the same rating or wattage. 2. Reinstall the power supplies with the same rating or wattage.

806f060d-0400xxxx Array [ComputerSystemElementName] has failed. (Drive 0)

Explanation: This message is for the use case when an implementation has detected that an Array Failed.

May also be shown as 806f060d0400xxxx or 0x806f060d0400xxxx

Severity: Error

Alert Category: Critical - Hard Disk drive

Serviceable: Yes

CIM Information: Prefix: PLAT and ID: 0176

SNMP Trap ID: 5

Automatically notify Support: Yes

User response: 1. Make sure that the RAID adapter firmware and hard disk drive firmware is at the latest level. 2. Make sure that the SAS cable is connected correctly. 3. Replace the SAS cable. 4. Replace the RAID adapter. 5. Replace the hard disk drive that is indicated by a lit status LED.

806f060d-0401xxxx • 806f060d-0403xxxx

806f060d-0401xxxx Array [ComputerSystemElementName] has failed. (Drive 1)

Explanation: This message is for the use case when an implementation has detected that an Array Failed.

May also be shown as 806f060d0401xxxx or 0x806f060d0401xxxx

Severity: Error

Alert Category: Critical - Hard Disk drive

Serviceable: Yes

CIM Information: Prefix: PLAT and ID: 0176

SNMP Trap ID: 5

Automatically notify Support: Yes

User response: 1. Make sure that the RAID adapter firmware and hard disk drive firmware is at the latest level. 2. Make sure that the SAS cable is connected correctly. 3. Replace the SAS cable. 4. Replace the RAID adapter. 5. Replace the hard disk drive that is indicated by a lit status LED.

806f060d-0402xxxx Array [ComputerSystemElementName] has failed. (Drive 2)

Explanation: This message is for the use case when an implementation has detected that an Array Failed.

May also be shown as 806f060d0402xxxx or 0x806f060d0402xxxx

Severity: Error

Alert Category: Critical - Hard Disk drive

Serviceable: Yes

CIM Information: Prefix: PLAT and ID: 0176

SNMP Trap ID: 5

Automatically notify Support: Yes

User response: 1. Make sure that the RAID adapter firmware and hard disk drive firmware is at the latest level. 2. Make sure that the SAS cable is connected correctly. 3. Replace the SAS cable. 4. Replace the RAID adapter. 5. Replace the hard disk drive that is indicated by a lit status LED.

806f060d-0403xxxx Array [ComputerSystemElementName] has failed. (Drive 3)

Explanation: This message is for the use case when an implementation has detected that an Array Failed.

May also be shown as 806f060d0403xxxx or 0x806f060d0403xxxx

Severity: Error

Alert Category: Critical - Hard Disk drive

Serviceable: Yes

CIM Information: Prefix: PLAT and ID: 0176

SNMP Trap ID: 5

Automatically notify Support: Yes

User response: 1. Make sure that the RAID adapter firmware and hard disk drive firmware is at the latest level. 2. Make sure that the SAS cable is connected correctly. 3. Replace the SAS cable. 4. Replace the RAID adapter. 5. Replace the hard disk drive that is indicated by a lit status LED.

806f060d-0404xxxx Array [ComputerSystemElementName] has failed. (Drive 4)

Explanation: This message is for the use case when an implementation has detected that an Array Failed.

May also be shown as 806f060d0404xxxx or 0x806f060d0404xxxx

Severity: Error

Alert Category: Critical - Hard Disk drive

Serviceable: Yes

CIM Information: Prefix: PLAT and ID: 0176

SNMP Trap ID: 5

Automatically notify Support: Yes

User response: 1. Make sure that the RAID adapter firmware and hard disk drive firmware is at the latest level. 2. Make sure that the SAS cable is connected correctly. 3. Replace the SAS cable. 4. Replace the RAID adapter. 5. Replace the hard disk drive that is indicated by a lit status LED.

806f060d-0405xxxx Array [ComputerSystemElementName] has failed. (Drive 5)

Explanation: This message is for the use case when an implementation has detected that an Array Failed.

May also be shown as 806f060d0405xxxx or 0x806f060d0405xxxx

Severity: Error

Alert Category: Critical - Hard Disk drive

Serviceable: Yes

CIM Information: Prefix: PLAT and ID: 0176

SNMP Trap ID: 5

Automatically notify Support: Yes

User response: 1. Make sure that the RAID adapter firmware and hard disk drive firmware is at the latest level. 2. Make sure that the SAS cable is connected correctly. 3. Replace the SAS cable. 4. Replace the RAID adapter. 5. Replace the hard disk drive that is indicated by a lit status LED.

806f060d-0406xxxx Array [ComputerSystemElementName] has failed. (Drive 6)

Explanation: This message is for the use case when an implementation has detected that an Array Failed.

May also be shown as 806f060d0406xxxx or 0x806f060d0406xxxx

Severity: Error

Alert Category: Critical - Hard Disk drive

Serviceable: Yes

CIM Information: Prefix: PLAT and ID: 0176

SNMP Trap ID: 5

Automatically notify Support: Yes

User response: 1. Make sure that the RAID adapter firmware and hard disk drive firmware is at the latest level. 2. Make sure that the SAS cable is connected correctly. 3. Replace the SAS cable. 4. Replace the RAID adapter. 5. Replace the hard disk drive that is indicated by a lit status LED.

806f060d-0407xxxx Array [ComputerSystemElementName] has failed. (Drive 7)

Explanation: This message is for the use case when an implementation has detected that an Array Failed.

May also be shown as 806f060d0407xxxx or 0x806f060d0407xxxx

Severity: Error

Alert Category: Critical - Hard Disk drive

Serviceable: Yes

CIM Information: Prefix: PLAT and ID: 0176

SNMP Trap ID: 5

Automatically notify Support: Yes

User response: 1. Make sure that the RAID adapter firmware and hard disk drive firmware is at the latest level. 2. Make sure that the SAS cable is connected correctly. 3. Replace the SAS cable. 4. Replace the RAID adapter. 5. Replace the hard disk drive that is indicated by a lit status LED.

806f070c-2001xxxx Configuration Error for [PhysicalMemoryElementName] on Subsystem [MemoryElementName]. (DIMM 1)

Explanation: This message is for the use case when an implementation has detected a Memory DIMM configuration error has been corrected.

May also be shown as 806f070c2001xxxx or 0x806f070c2001xxxx

Severity: Error

Alert Category: Critical - Memory

Serviceable: Yes

CIM Information: Prefix: PLAT and ID: 0126

SNMP Trap ID: 41

Automatically notify Support: No

User response: Make sure that DIMMs are installed in the correct sequence and have the same size, type, speed, and technology.

806f070c-2002xxxx Configuration Error for [PhysicalMemoryElementName] on Subsystem [MemoryElementName]. (DIMM 2)

Explanation: This message is for the use case when an implementation has detected a Memory DIMM configuration error has been corrected.

May also be shown as 806f070c2002xxxx or 0x806f070c2002xxxx

Severity: Error

Alert Category: Critical - Memory

Serviceable: Yes

CIM Information: Prefix: PLAT and ID: 0126

SNMP Trap ID: 41

Automatically notify Support: No

User response: Make sure that DIMMs are installed in the correct sequence and have the same size, type, speed, and technology.

**806f070c-2003xxxx Configuration Error for [PhysicalMemoryElementName] on Subsystem
[MemoryElementName]. (DIMM 3)**

Explanation: This message is for the use case when an implementation has detected a Memory DIMM configuration error has been corrected.

May also be shown as 806f070c2003xxxx or 0x806f070c2003xxxx

Severity: Error

Alert Category: Critical - Memory

Serviceable: Yes

CIM Information: Prefix: PLAT and ID: 0126

SNMP Trap ID: 41

Automatically notify Support: No

User response: Make sure that DIMMs are installed in the correct sequence and have the same size, type, speed, and technology.

**806f070c-2004xxxx Configuration Error for [PhysicalMemoryElementName] on Subsystem
[MemoryElementName]. (DIMM 4)**

Explanation: This message is for the use case when an implementation has detected a Memory DIMM configuration error has been corrected.

May also be shown as 806f070c2004xxxx or 0x806f070c2004xxxx

Severity: Error

Alert Category: Critical - Memory

Serviceable: Yes

CIM Information: Prefix: PLAT and ID: 0126

SNMP Trap ID: 41

Automatically notify Support: No

User response: Make sure that DIMMs are installed in the correct sequence and have the same size, type, speed, and technology.

**806f070c-2005xxxx Configuration Error for [PhysicalMemoryElementName] on Subsystem
[MemoryElementName]. (DIMM 5)**

Explanation: This message is for the use case when an implementation has detected a Memory DIMM configuration error has been corrected.

May also be shown as 806f070c2005xxxx or 0x806f070c2005xxxx

Severity: Error

Alert Category: Critical - Memory

Serviceable: Yes

CIM Information: Prefix: PLAT and ID: 0126

SNMP Trap ID: 41

Automatically notify Support: No

User response: Make sure that DIMMs are installed in the correct sequence and have the same size, type, speed, and technology.

**806f070c-2006xxxx Configuration Error for [PhysicalMemoryElementName] on Subsystem
[MemoryElementName]. (DIMM 6)**

Explanation: This message is for the use case when an implementation has detected a Memory DIMM configuration error has been corrected.

May also be shown as 806f070c2006xxxx or 0x806f070c2006xxxx

Severity: Error

Alert Category: Critical - Memory

Serviceable: Yes

CIM Information: Prefix: PLAT and ID: 0126

SNMP Trap ID: 41

Automatically notify Support: No

User response: Make sure that DIMMs are installed in the correct sequence and have the same size, type, speed, and technology.

**806f070c-2007xxxx Configuration Error for [PhysicalMemoryElementName] on Subsystem
[MemoryElementName]. (DIMM 7)**

Explanation: This message is for the use case when an implementation has detected a Memory DIMM configuration error has been corrected.

May also be shown as 806f070c2007xxxx or 0x806f070c2007xxxx

Severity: Error

Alert Category: Critical - Memory

Serviceable: Yes

CIM Information: Prefix: PLAT and ID: 0126

SNMP Trap ID: 41

Automatically notify Support: No

User response: Make sure that DIMMs are installed in the correct sequence and have the same size, type, speed, and technology.

**806f070c-2008xxxx Configuration Error for [PhysicalMemoryElementName] on Subsystem
[MemoryElementName]. (DIMM 8)**

Explanation: This message is for the use case when an implementation has detected a Memory DIMM configuration error has been corrected.

May also be shown as 806f070c2008xxxx or 0x806f070c2008xxxx

Severity: Error

Alert Category: Critical - Memory

Serviceable: Yes

CIM Information: Prefix: PLAT and ID: 0126

SNMP Trap ID: 41

Automatically notify Support: No

User response: Make sure that DIMMs are installed in the correct sequence and have the same size, type, speed, and technology.

806f070c-2009xxxx Configuration Error for [PhysicalMemoryElementName] on Subsystem [MemoryElementName]. (DIMM 9)

Explanation: This message is for the use case when an implementation has detected a Memory DIMM configuration error has been corrected.

May also be shown as 806f070c2009xxxx or 0x806f070c2009xxxx

Severity: Error

Alert Category: Critical - Memory

Serviceable: Yes

CIM Information: Prefix: PLAT and ID: 0126

SNMP Trap ID: 41

Automatically notify Support: No

User response: Make sure that DIMMs are installed in the correct sequence and have the same size, type, speed, and technology.

806f070c-200axxxx Configuration Error for [PhysicalMemoryElementName] on Subsystem [MemoryElementName]. (DIMM 10)

Explanation: This message is for the use case when an implementation has detected a Memory DIMM configuration error has been corrected.

May also be shown as 806f070c200axxxx or 0x806f070c200axxxx

Severity: Error

Alert Category: Critical - Memory

Serviceable: Yes

CIM Information: Prefix: PLAT and ID: 0126

SNMP Trap ID: 41

Automatically notify Support: No

User response: Make sure that DIMMs are installed in the correct sequence and have the same size, type, speed, and technology.

806f070c-200bxxxx Configuration Error for [PhysicalMemoryElementName] on Subsystem [MemoryElementName]. (DIMM 11)

Explanation: This message is for the use case when an implementation has detected a Memory DIMM configuration error has been corrected.

May also be shown as 806f070c200bxxxx or 0x806f070c200bxxxx

Severity: Error

Alert Category: Critical - Memory

Serviceable: Yes

CIM Information: Prefix: PLAT and ID: 0126

SNMP Trap ID: 41

Automatically notify Support: No

User response: Make sure that DIMMs are installed in the correct sequence and have the same size, type, speed, and technology.

**806f070c-200cxxxx Configuration Error for [PhysicalMemoryElementName] on Subsystem
[MemoryElementName]. (DIMM 12)**

Explanation: This message is for the use case when an implementation has detected a Memory DIMM configuration error has been corrected.

May also be shown as 806f070c200cxxxx or 0x806f070c200cxxxx

Severity: Error

Alert Category: Critical - Memory

Serviceable: Yes

CIM Information: Prefix: PLAT and ID: 0126

SNMP Trap ID: 41

Automatically notify Support: No

User response: Make sure that DIMMs are installed in the correct sequence and have the same size, type, speed, and technology.

**806f070c-200dxxxx Configuration Error for [PhysicalMemoryElementName] on Subsystem
[MemoryElementName]. (DIMM 13)**

Explanation: This message is for the use case when an implementation has detected a Memory DIMM configuration error has been corrected.

May also be shown as 806f070c200dxxxx or 0x806f070c200dxxxx

Severity: Error

Alert Category: Critical - Memory

Serviceable: Yes

CIM Information: Prefix: PLAT and ID: 0126

SNMP Trap ID: 41

Automatically notify Support: No

User response: Make sure that DIMMs are installed in the correct sequence and have the same size, type, speed, and technology.

**806f070c-200exxxx Configuration Error for [PhysicalMemoryElementName] on Subsystem
[MemoryElementName]. (DIMM 14)**

Explanation: This message is for the use case when an implementation has detected a Memory DIMM configuration error has been corrected.

May also be shown as 806f070c200exxxx or 0x806f070c200exxxx

Severity: Error

Alert Category: Critical - Memory

Serviceable: Yes

CIM Information: Prefix: PLAT and ID: 0126

SNMP Trap ID: 41

Automatically notify Support: No

User response: Make sure that DIMMs are installed in the correct sequence and have the same size, type, speed, and technology.

806f070c-200fxxxx Configuration Error for [PhysicalMemoryElementName] on Subsystem [MemoryElementName]. (DIMM 15)

Explanation: This message is for the use case when an implementation has detected a Memory DIMM configuration error has been corrected.

May also be shown as 806f070c200fxxxx or 0x806f070c200fxxxx

Severity: Error

Alert Category: Critical - Memory

Serviceable: Yes

CIM Information: Prefix: PLAT and ID: 0126

SNMP Trap ID: 41

Automatically notify Support: No

User response: Make sure that DIMMs are installed in the correct sequence and have the same size, type, speed, and technology.

806f070c-2010xxxx Configuration Error for [PhysicalMemoryElementName] on Subsystem [MemoryElementName]. (DIMM 16)

Explanation: This message is for the use case when an implementation has detected a Memory DIMM configuration error has been corrected.

May also be shown as 806f070c2010xxxx or 0x806f070c2010xxxx

Severity: Error

Alert Category: Critical - Memory

Serviceable: Yes

CIM Information: Prefix: PLAT and ID: 0126

SNMP Trap ID: 41

Automatically notify Support: No

User response: Make sure that DIMMs are installed in the correct sequence and have the same size, type, speed, and technology.

806f070c-2011xxxx Configuration Error for [PhysicalMemoryElementName] on Subsystem [MemoryElementName]. (DIMM 17)

Explanation: This message is for the use case when an implementation has detected a Memory DIMM configuration error has been corrected.

May also be shown as 806f070c2011xxxx or 0x806f070c2011xxxx

Severity: Error

Alert Category: Critical - Memory

Serviceable: Yes

CIM Information: Prefix: PLAT and ID: 0126

SNMP Trap ID: 41

Automatically notify Support: No

User response: Make sure that DIMMs are installed in the correct sequence and have the same size, type, speed, and technology.

806f070c-2012xxxx Configuration Error for [PhysicalMemoryElementName] on Subsystem [MemoryElementName]. (DIMM 18)

Explanation: This message is for the use case when an implementation has detected a Memory DIMM configuration error has been corrected.

May also be shown as 806f070c2012xxxx or 0x806f070c2012xxxx

Severity: Error

Alert Category: Critical - Memory

Serviceable: Yes

CIM Information: Prefix: PLAT and ID: 0126

SNMP Trap ID: 41

Automatically notify Support: No

User response: Make sure that DIMMs are installed in the correct sequence and have the same size, type, speed, and technology.

806f070c-2581xxxx Configuration Error for [PhysicalMemoryElementName] on Subsystem [MemoryElementName]. (All DIMMS)

Explanation: This message is for the use case when an implementation has detected a Memory DIMM configuration error has been corrected.

May also be shown as 806f070c2581xxxx or 0x806f070c2581xxxx

Severity: Error

Alert Category: Critical - Memory

Serviceable: Yes

CIM Information: Prefix: PLAT and ID: 0126

SNMP Trap ID: 41

Automatically notify Support: No

User response: Make sure that DIMMs are installed in the correct sequence and have the same size, type, speed, and technology. One of the DIMMs :

806f070d-0400xxxx Rebuild in progress for Array in system [ComputerSystemElementName]. (Drive 0)

Explanation: This message is for the use case when an implementation has detected that an Array Rebuild is in Progress.

May also be shown as 806f070d0400xxxx or 0x806f070d0400xxxx

Severity: Info

Alert Category: System - Other

Serviceable: No

CIM Information: Prefix: PLAT and ID: 0178

SNMP Trap ID:

Automatically notify Support: No

User response: No action; information only.

806f070d-0401xxxx Rebuild in progress for Array in system [ComputerSystemElementName]. (Drive 1)

Explanation: This message is for the use case when an implementation has detected that an Array Rebuild is in Progress.

May also be shown as 806f070d0401xxxx or 0x806f070d0401xxxx

Severity: Info

Alert Category: System - Other

Serviceable: No

CIM Information: Prefix: PLAT and ID: 0178

SNMP Trap ID:

Automatically notify Support: No

User response: No action; information only.

806f070d-0402xxxx Rebuild in progress for Array in system [ComputerSystemElementName]. (Drive 2)

Explanation: This message is for the use case when an implementation has detected that an Array Rebuild is in Progress.

May also be shown as 806f070d0402xxxx or 0x806f070d0402xxxx

Severity: Info

Alert Category: System - Other

Serviceable: No

CIM Information: Prefix: PLAT and ID: 0178

SNMP Trap ID:

Automatically notify Support: No

User response: No action; information only.

806f070d-0403xxxx Rebuild in progress for Array in system [ComputerSystemElementName]. (Drive 3)

Explanation: This message is for the use case when an implementation has detected that an Array Rebuild is in Progress.

May also be shown as 806f070d0403xxxx or 0x806f070d0403xxxx

Severity: Info

Alert Category: System - Other

Serviceable: No

CIM Information: Prefix: PLAT and ID: 0178

SNMP Trap ID:

Automatically notify Support: No

User response: No action; information only.

806f070d-0404xxxx • 806f070d-0406xxxx

806f070d-0404xxxx Rebuild in progress for Array in system [ComputerSystemElementName]. (Drive 4)

Explanation: This message is for the use case when an implementation has detected that an Array Rebuild is in Progress.

May also be shown as 806f070d0404xxxx or 0x806f070d0404xxxx

Severity: Info

Alert Category: System - Other

Serviceable: No

CIM Information: Prefix: PLAT and ID: 0178

SNMP Trap ID:

Automatically notify Support: No

User response: No action; information only.

806f070d-0405xxxx Rebuild in progress for Array in system [ComputerSystemElementName]. (Drive 5)

Explanation: This message is for the use case when an implementation has detected that an Array Rebuild is in Progress.

May also be shown as 806f070d0405xxxx or 0x806f070d0405xxxx

Severity: Info

Alert Category: System - Other

Serviceable: No

CIM Information: Prefix: PLAT and ID: 0178

SNMP Trap ID:

Automatically notify Support: No

User response: No action; information only.

806f070d-0406xxxx Rebuild in progress for Array in system [ComputerSystemElementName]. (Drive 6)

Explanation: This message is for the use case when an implementation has detected that an Array Rebuild is in Progress.

May also be shown as 806f070d0406xxxx or 0x806f070d0406xxxx

Severity: Info

Alert Category: System - Other

Serviceable: No

CIM Information: Prefix: PLAT and ID: 0178

SNMP Trap ID:

Automatically notify Support: No

User response: No action; information only.

806f070d-0407xxxx Rebuild in progress for Array in system [ComputerSystemElementName]. (Drive 7)

Explanation: This message is for the use case when an implementation has detected that an Array Rebuild is in Progress.

May also be shown as 806f070d0407xxxx or 0x806f070d0407xxxx

Severity: Info

Alert Category: System - Other

Serviceable: No

CIM Information: Prefix: PLAT and ID: 0178

SNMP Trap ID:

Automatically notify Support: No

User response: No action; information only.

806f0807-0301xxxx [ProcessorElementName] has been Disabled. (CPU 1)

Explanation: This message is for the use case when an implementation has detected a Processor has been Disabled.

May also be shown as 806f08070301xxxx or 0x806f08070301xxxx

Severity: Info

Alert Category: System - Other

Serviceable: No

CIM Information: Prefix: PLAT and ID: 0061

SNMP Trap ID:

Automatically notify Support: No

User response: No action; information only.

806f0807-0302xxxx [ProcessorElementName] has been Disabled. (CPU 2)

Explanation: This message is for the use case when an implementation has detected a Processor has been Disabled.

May also be shown as 806f08070302xxxx or 0x806f08070302xxxx

Severity: Info

Alert Category: System - Other

Serviceable: No

CIM Information: Prefix: PLAT and ID: 0061

SNMP Trap ID:

Automatically notify Support: No

User response: No action; information only.

806f0807-2584xxxx [ProcessorElementName] has been Disabled. (All CPUs)

Explanation: This message is for the use case when an implementation has detected a Processor has been Disabled.

May also be shown as 806f08072584xxxx or 0x806f08072584xxxx

Severity: Info

Alert Category: System - Other

Serviceable: No

CIM Information: Prefix: PLAT and ID: 0061

SNMP Trap ID:

Automatically notify Support: No

User response: No action; information only. One of the CPUs :

806f0813-2581xxxx A Uncorrectable Bus Error has occurred on system [ComputerSystemElementName]. (DIMMs)

Explanation: This message is for the use case when an implementation has detected a Bus Uncorrectable Error.

May also be shown as 806f08132581xxxx or 0x806f08132581xxxx

Severity: Error

Alert Category: Critical - Other

Serviceable: Yes

CIM Information: Prefix: PLAT and ID: 0240

SNMP Trap ID: 50

Automatically notify Support: Yes

User response: 1. Check the system-event log. 2. (Trained technician only) Remove the failing microprocessor from the system board (see Removing a microprocessor and heat sink). 3. Check for a server firmware update. Important: Some cluster solutions require specific code levels or coordinated code updates. If the device is part of a cluster solution, verify that the latest level of code is supported for the cluster solution before you update the code. 4. Make sure that the two microprocessors are matching. 5. (Trained technician only) Replace the system board.

806f0813-2582xxxx A Uncorrectable Bus Error has occurred on system [ComputerSystemElementName]. (PCIs)

Explanation: This message is for the use case when an implementation has detected a Bus Uncorrectable Error.

May also be shown as 806f08132582xxxx or 0x806f08132582xxxx

Severity: Error

Alert Category: Critical - Other

Serviceable: Yes

CIM Information: Prefix: PLAT and ID: 0240

SNMP Trap ID: 50

Automatically notify Support: Yes

User response: 1. Check the system-event log. 2. (Trained technician only) Remove the failing microprocessor from the system board (see Removing a microprocessor and heat sink). 3. Check for a server firmware update. Important: Some cluster solutions require specific code levels or coordinated code updates. If the device is part of a cluster solution, verify that the latest level of code is supported for the cluster solution before you update the code. 4. Make sure that the two microprocessors are matching. 5. (Trained technician only) Replace the system board.

806f0813-2584xxxx A **Uncorrectable Bus Error has occurred on system [ComputerSystemElementName]. (CPUs)**

Explanation: This message is for the use case when an implementation has detected a Bus Uncorrectable Error.

May also be shown as 806f08132584xxxx or 0x806f08132584xxxx

Severity: Error

Alert Category: Critical - Other

Serviceable: Yes

CIM Information: **Prefix:** PLAT and **ID:** 0240

SNMP Trap ID: 50

Automatically notify Support: Yes

User response: 1. Check the system-event log. 2. (Trained technician only) Remove the failing microprocessor from the system board (see Removing a microprocessor and heat sink). 3. Check for a server firmware update. Important: Some cluster solutions require specific code levels or coordinated code updates. If the device is part of a cluster solution, verify that the latest level of code is supported for the cluster solution before you update the code. 4. Make sure that the two microprocessors are matching. 5. (Trained technician only) Replace the system board.

806f0823-2101xxxx **Watchdog Timer interrupt occurred for [WatchdogElementName]. (Watchdog)**

Explanation: This message is for the use case when an implementation has detected a Watchdog Timer interrupt occurred.

May also be shown as 806f08232101xxxx or 0x806f08232101xxxx

Severity: Info

Alert Category: System - Other

Serviceable: No

CIM Information: **Prefix:** PLAT and **ID:** 0376

SNMP Trap ID:

Automatically notify Support: No

User response: No action; information only.

806f0a07-0301xxxx **[ProcessorElementName] is operating in a Degraded State. (CPU 1)**

Explanation: This message is for the use case when an implementation has detected a Processor is running in the Degraded state.

May also be shown as 806f0a070301xxxx or 0x806f0a070301xxxx

Severity: Warning

Alert Category: Warning - CPU

Serviceable: Yes

CIM Information: **Prefix:** PLAT and **ID:** 0038

SNMP Trap ID: 42

Automatically notify Support: No

User response: 1. Make sure that the fans are operating, that there are no obstructions to the airflow (front and rear of the server), that the air baffles are in place and correctly installed, and that the server cover is installed and completely closed. 2. Check the ambient temperature. You must be operating within the specifications. 3. Make sure that the heat sink for microprocessor n is installed correctly. 4. (Trained technician only) Replace microprocessor n. (n = microprocessor number)

806f0a07-0302xxxx [ProcessorElementName] is operating in a Degraded State. (CPU 2)

Explanation: This message is for the use case when an implementation has detected a Processor is running in the Degraded state.

May also be shown as 806f0a070302xxxx or 0x806f0a070302xxxx

Severity: Warning

Alert Category: Warning - CPU

Serviceable: Yes

CIM Information: Prefix: PLAT and ID: 0038

SNMP Trap ID: 42

Automatically notify Support: No

User response: 1. Make sure that the fans are operating, that there are no obstructions to the airflow (front and rear of the server), that the air baffles are in place and correctly installed, and that the server cover is installed and completely closed. 2. Check the ambient temperature. You must be operating within the specifications. 3. Make sure that the heat sink for microprocessor n is installed correctly. 4. (Trained technician only) Replace microprocessor n. (n = microprocessor number)

81010002-2801xxxx Numeric sensor [NumericSensorElementName] going low (lower non-critical) has deasserted. (CMOS Battery)

Explanation: This message is for the use case when an implementation has detected a Lower Non-critical sensor going low has deasserted.

May also be shown as 810100022801xxxx or 0x810100022801xxxx

Severity: Info

Alert Category: Warning - Voltage

Serviceable: No

CIM Information: Prefix: PLAT and ID: 0477

SNMP Trap ID: 13

Automatically notify Support: No

User response: No action; information only.

81010202-0701xxxx Numeric sensor [NumericSensorElementName] going low (lower critical) has deasserted. (Planar 12V)

Explanation: This message is for the use case when an implementation has detected a Lower Critical sensor going low has deasserted.

May also be shown as 810102020701xxxx or 0x810102020701xxxx

Severity: Info

Alert Category: Critical - Voltage

Serviceable: No

CIM Information: Prefix: PLAT and ID: 0481

SNMP Trap ID: 1

Automatically notify Support: No

User response: No action; information only. Planar 3.3V : Planar 5V :

81010202-2801xxxx Numeric sensor [NumericSensorElementName] going low (lower critical) has deasserted. (CMOS Battery)

Explanation: This message is for the use case when an implementation has detected a Lower Critical sensor going low has deasserted.

May also be shown as 810102022801xxxx or 0x810102022801xxxx

Severity: Info

Alert Category: Critical - Voltage

Serviceable: No

CIM Information: Prefix: PLAT and ID: 0481

SNMP Trap ID: 1

Automatically notify Support: No

User response: No action; information only.

81010204-1d01xxxx Numeric sensor [NumericSensorElementName] going low (lower critical) has deasserted. (Fan 1A Tach)

Explanation: This message is for the use case when an implementation has detected a Lower Critical sensor going low has deasserted.

May also be shown as 810102041d01xxxx or 0x810102041d01xxxx

Severity: Info

Alert Category: Critical - Fan Failure

Serviceable: No

CIM Information: Prefix: PLAT and ID: 0481

SNMP Trap ID: 11

Automatically notify Support: No

User response: No action; information only. Fan 1B Tach :

81010204-1d02xxxx Numeric sensor [NumericSensorElementName] going low (lower critical) has deasserted. (Fan 2A Tach)

Explanation: This message is for the use case when an implementation has detected a Lower Critical sensor going low has deasserted.

May also be shown as 810102041d02xxxx or 0x810102041d02xxxx

Severity: Info

Alert Category: Critical - Fan Failure

Serviceable: No

CIM Information: Prefix: PLAT and ID: 0481

SNMP Trap ID: 11

Automatically notify Support: No

User response: No action; information only. Fan 2B Tach :

81010204-1d03xxxx • 81010204-1d05xxxx

81010204-1d03xxxx Numeric sensor [NumericSensorElementName] going low (lower critical) has deasserted. (Fan 3A Tach)

Explanation: This message is for the use case when an implementation has detected a Lower Critical sensor going low has deasserted.

May also be shown as 810102041d03xxxx or 0x810102041d03xxxx

Severity: Info

Alert Category: Critical - Fan Failure

Serviceable: No

CIM Information: Prefix: PLAT and ID: 0481

SNMP Trap ID: 11

Automatically notify Support: No

User response: No action; information only. Fan 3B Tach :

81010204-1d04xxxx Numeric sensor [NumericSensorElementName] going low (lower critical) has deasserted. (Fan 4A Tach)

Explanation: This message is for the use case when an implementation has detected a Lower Critical sensor going low has deasserted.

May also be shown as 810102041d04xxxx or 0x810102041d04xxxx

Severity: Info

Alert Category: Critical - Fan Failure

Serviceable: No

CIM Information: Prefix: PLAT and ID: 0481

SNMP Trap ID: 11

Automatically notify Support: No

User response: No action; information only. Fan 4B Tach :

81010204-1d05xxxx Numeric sensor [NumericSensorElementName] going low (lower critical) has deasserted. (Fan 5A Tach)

Explanation: This message is for the use case when an implementation has detected a Lower Critical sensor going low has deasserted.

May also be shown as 810102041d05xxxx or 0x810102041d05xxxx

Severity: Info

Alert Category: Critical - Fan Failure

Serviceable: No

CIM Information: Prefix: PLAT and ID: 0481

SNMP Trap ID: 11

Automatically notify Support: No

User response: No action; information only. Fan 5B Tach :

81010204-1d06xxxx Numeric sensor [NumericSensorElementName] going low (lower critical) has deasserted. (Fan 6A Tach)

Explanation: This message is for the use case when an implementation has detected a Lower Critical sensor going low has deasserted.

May also be shown as 810102041d06xxxx or 0x810102041d06xxxx

Severity: Info

Alert Category: Critical - Fan Failure

Serviceable: No

CIM Information: Prefix: PLAT and ID: 0481

SNMP Trap ID: 11

Automatically notify Support: No

User response: No action; information only. Fan 6B Tach :

81010701-0c01xxxx Numeric sensor [NumericSensorElementName] going high (upper non-critical) has deasserted. (Ambient Temp)

Explanation: This message is for the use case when an implementation has detected an Upper Non-critical sensor going high has deasserted.

May also be shown as 810107010c01xxxx or 0x810107010c01xxxx

Severity: Info

Alert Category: Warning - Temperature

Serviceable: No

CIM Information: Prefix: PLAT and ID: 0491

SNMP Trap ID: 12

Automatically notify Support: No

User response: No action; information only.

81010901-0c01xxxx Numeric sensor [NumericSensorElementName] going high (upper critical) has deasserted. (Ambient Temp)

Explanation: This message is for the use case when an implementation has detected an Upper Critical sensor going high has deasserted.

May also be shown as 810109010c01xxxx or 0x810109010c01xxxx

Severity: Info

Alert Category: Critical - Temperature

Serviceable: No

CIM Information: Prefix: PLAT and ID: 0495

SNMP Trap ID: 0

Automatically notify Support: No

User response: No action; information only.

81010902-0701xxxx • 81030012-2301xxxx

81010902-0701xxxx Numeric sensor [NumericSensorElementName] going high (upper critical) has deasserted. (Planar 12V)

Explanation: This message is for the use case when an implementation has detected an Upper Critical sensor going high has deasserted.

May also be shown as 810109020701xxxx or 0x810109020701xxxx

Severity: Info

Alert Category: Critical - Voltage

Serviceable: No

CIM Information: Prefix: PLAT and ID: 0495

SNMP Trap ID: 1

Automatically notify Support: No

User response: No action; information only. Planar 3.3V : Planar 5V :

81010b01-0c01xxxx Numeric sensor [NumericSensorElementName] going high (upper non-recoverable) has deasserted. (Ambient Temp)

Explanation: This message is for the use case when an implementation has detected an Upper Non-recoverable sensor going high has deasserted.

May also be shown as 81010b010c01xxxx or 0x81010b010c01xxxx

Severity: Info

Alert Category: Critical - Temperature

Serviceable: No

CIM Information: Prefix: PLAT and ID: 0499

SNMP Trap ID: 0

Automatically notify Support: No

User response: No action; information only.

81030012-2301xxxx Sensor [SensorElementName] has asserted. (OS RealTime Mod)

Explanation: This message is for the use case when an implementation has detected a Sensor has asserted.

May also be shown as 810300122301xxxx or 0x810300122301xxxx

Severity: Info

Alert Category: System - Other

Serviceable: No

CIM Information: Prefix: PLAT and ID: 0508

SNMP Trap ID:

Automatically notify Support: No

User response: No action; information only.

81070201-0301xxxx Sensor [SensorElementName] has transitioned to a less severe state from critical. (CPU 1 OverTemp)

Explanation: This message is for the use case when an implementation has detected a Sensor transition to less severe from critical.

May also be shown as 810702010301xxxx or 0x810702010301xxxx

Severity: Info

Alert Category: Critical - Temperature

Serviceable: No

CIM Information: Prefix: PLAT and ID: 0523

SNMP Trap ID: 0

Automatically notify Support: No

User response: No action; information only.

81070201-0302xxxx Sensor [SensorElementName] has transitioned to a less severe state from critical. (CPU 2 OverTemp)

Explanation: This message is for the use case when an implementation has detected a Sensor transition to less severe from critical.

May also be shown as 810702010302xxxx or 0x810702010302xxxx

Severity: Info

Alert Category: Critical - Temperature

Serviceable: No

CIM Information: Prefix: PLAT and ID: 0523

SNMP Trap ID: 0

Automatically notify Support: No

User response: No action; information only.

81070201-2001xxxx Sensor [SensorElementName] has transitioned to a less severe state from critical. (DIMM 1 Temp)

Explanation: This message is for the use case when an implementation has detected a Sensor transition to less severe from critical.

May also be shown as 810702012001xxxx or 0x810702012001xxxx

Severity: Info

Alert Category: Critical - Temperature

Serviceable: No

CIM Information: Prefix: PLAT and ID: 0523

SNMP Trap ID: 0

Automatically notify Support: No

User response: No action; information only.

81070201-2002xxxx • 81070201-2004xxxx

81070201-2002xxxx Sensor [SensorElementName] has transitioned to a less severe state from critical. (DIMM 2 Temp)

Explanation: This message is for the use case when an implementation has detected a Sensor transition to less severe from critical.

May also be shown as 810702012002xxxx or 0x810702012002xxxx

Severity: Info

Alert Category: Critical - Temperature

Serviceable: No

CIM Information: Prefix: PLAT and ID: 0523

SNMP Trap ID: 0

Automatically notify Support: No

User response: No action; information only.

81070201-2003xxxx Sensor [SensorElementName] has transitioned to a less severe state from critical. (DIMM 3 Temp)

Explanation: This message is for the use case when an implementation has detected a Sensor transition to less severe from critical.

May also be shown as 810702012003xxxx or 0x810702012003xxxx

Severity: Info

Alert Category: Critical - Temperature

Serviceable: No

CIM Information: Prefix: PLAT and ID: 0523

SNMP Trap ID: 0

Automatically notify Support: No

User response: No action; information only.

81070201-2004xxxx Sensor [SensorElementName] has transitioned to a less severe state from critical. (DIMM 4 Temp)

Explanation: This message is for the use case when an implementation has detected a Sensor transition to less severe from critical.

May also be shown as 810702012004xxxx or 0x810702012004xxxx

Severity: Info

Alert Category: Critical - Temperature

Serviceable: No

CIM Information: Prefix: PLAT and ID: 0523

SNMP Trap ID: 0

Automatically notify Support: No

User response: No action; information only.

81070201-2005xxxx Sensor [SensorElementName] has transitioned to a less severe state from critical. (DIMM 5 Temp)

Explanation: This message is for the use case when an implementation has detected a Sensor transition to less severe from critical.

May also be shown as 810702012005xxxx or 0x810702012005xxxx

Severity: Info

Alert Category: Critical - Temperature

Serviceable: No

CIM Information: Prefix: PLAT and ID: 0523

SNMP Trap ID: 0

Automatically notify Support: No

User response: No action; information only.

81070201-2006xxxx Sensor [SensorElementName] has transitioned to a less severe state from critical. (DIMM 6 Temp)

Explanation: This message is for the use case when an implementation has detected a Sensor transition to less severe from critical.

May also be shown as 810702012006xxxx or 0x810702012006xxxx

Severity: Info

Alert Category: Critical - Temperature

Serviceable: No

CIM Information: Prefix: PLAT and ID: 0523

SNMP Trap ID: 0

Automatically notify Support: No

User response: No action; information only.

81070201-2007xxxx Sensor [SensorElementName] has transitioned to a less severe state from critical. (DIMM 7 Temp)

Explanation: This message is for the use case when an implementation has detected a Sensor transition to less severe from critical.

May also be shown as 810702012007xxxx or 0x810702012007xxxx

Severity: Info

Alert Category: Critical - Temperature

Serviceable: No

CIM Information: Prefix: PLAT and ID: 0523

SNMP Trap ID: 0

Automatically notify Support: No

User response: No action; information only.

81070201-2008xxxx Sensor [SensorElementName] has transitioned to a less severe state from critical. (DIMM 8 Temp)

Explanation: This message is for the use case when an implementation has detected a Sensor transition to less severe from critical.

May also be shown as 810702012008xxxx or 0x810702012008xxxx

Severity: Info

Alert Category: Critical - Temperature

Serviceable: No

CIM Information: Prefix: PLAT and ID: 0523

SNMP Trap ID: 0

Automatically notify Support: No

User response: No action; information only.

81070201-2009xxxx Sensor [SensorElementName] has transitioned to a less severe state from critical. (DIMM 9 Temp)

Explanation: This message is for the use case when an implementation has detected a Sensor transition to less severe from critical.

May also be shown as 810702012009xxxx or 0x810702012009xxxx

Severity: Info

Alert Category: Critical - Temperature

Serviceable: No

CIM Information: Prefix: PLAT and ID: 0523

SNMP Trap ID: 0

Automatically notify Support: No

User response: No action; information only.

81070201-200axxxx Sensor [SensorElementName] has transitioned to a less severe state from critical. (DIMM 10 Temp)

Explanation: This message is for the use case when an implementation has detected a Sensor transition to less severe from critical.

May also be shown as 81070201200axxxx or 0x81070201200axxxx

Severity: Info

Alert Category: Critical - Temperature

Serviceable: No

CIM Information: Prefix: PLAT and ID: 0523

SNMP Trap ID: 0

Automatically notify Support: No

User response: No action; information only.

81070201-200bxxxx Sensor [SensorElementName] has transitioned to a less severe state from critical. (DIMM 11 Temp)

Explanation: This message is for the use case when an implementation has detected a Sensor transition to less severe from critical.

May also be shown as 81070201200bxxxx or 0x81070201200bxxxx

Severity: Info

Alert Category: Critical - Temperature

Serviceable: No

CIM Information: Prefix: PLAT and ID: 0523

SNMP Trap ID: 0

Automatically notify Support: No

User response: No action; information only.

81070201-200cxxxx Sensor [SensorElementName] has transitioned to a less severe state from critical. (DIMM 12 Temp)

Explanation: This message is for the use case when an implementation has detected a Sensor transition to less severe from critical.

May also be shown as 81070201200cxxxx or 0x81070201200cxxxx

Severity: Info

Alert Category: Critical - Temperature

Serviceable: No

CIM Information: Prefix: PLAT and ID: 0523

SNMP Trap ID: 0

Automatically notify Support: No

User response: No action; information only.

81070201-200dxxxx Sensor [SensorElementName] has transitioned to a less severe state from critical. (DIMM 13 Temp)

Explanation: This message is for the use case when an implementation has detected a Sensor transition to less severe from critical.

May also be shown as 81070201200dxxxx or 0x81070201200dxxxx

Severity: Info

Alert Category: Critical - Temperature

Serviceable: No

CIM Information: Prefix: PLAT and ID: 0523

SNMP Trap ID: 0

Automatically notify Support: No

User response: No action; information only.

81070201-200exxxx Sensor [SensorElementName] has transitioned to a less severe state from critical. (DIMM 14 Temp)

Explanation: This message is for the use case when an implementation has detected a Sensor transition to less severe from critical.

May also be shown as 81070201200exxxx or 0x81070201200exxxx

Severity: Info

Alert Category: Critical - Temperature

Serviceable: No

CIM Information: Prefix: PLAT and ID: 0523

SNMP Trap ID: 0

Automatically notify Support: No

User response: No action; information only.

81070201-200fxxxx Sensor [SensorElementName] has transitioned to a less severe state from critical. (DIMM 15 Temp)

Explanation: This message is for the use case when an implementation has detected a Sensor transition to less severe from critical.

May also be shown as 81070201200fxxxx or 0x81070201200fxxxx

Severity: Info

Alert Category: Critical - Temperature

Serviceable: No

CIM Information: Prefix: PLAT and ID: 0523

SNMP Trap ID: 0

Automatically notify Support: No

User response: No action; information only.

81070201-2010xxxx Sensor [SensorElementName] has transitioned to a less severe state from critical. (DIMM 16 Temp)

Explanation: This message is for the use case when an implementation has detected a Sensor transition to less severe from critical.

May also be shown as 810702012010xxxx or 0x810702012010xxxx

Severity: Info

Alert Category: Critical - Temperature

Serviceable: No

CIM Information: Prefix: PLAT and ID: 0523

SNMP Trap ID: 0

Automatically notify Support: No

User response: No action; information only.

81070201-2011xxxx Sensor [SensorElementName] has transitioned to a less severe state from critical. (DIMM 17 Temp)

Explanation: This message is for the use case when an implementation has detected a Sensor transition to less severe from critical.

May also be shown as 810702012011xxxx or 0x810702012011xxxx

Severity: Info

Alert Category: Critical - Temperature

Serviceable: No

CIM Information: Prefix: PLAT and ID: 0523

SNMP Trap ID: 0

Automatically notify Support: No

User response: No action; information only.

81070201-2012xxxx Sensor [SensorElementName] has transitioned to a less severe state from critical. (DIMM 18 Temp)

Explanation: This message is for the use case when an implementation has detected a Sensor transition to less severe from critical.

May also be shown as 810702012012xxxx or 0x810702012012xxxx

Severity: Info

Alert Category: Critical - Temperature

Serviceable: No

CIM Information: Prefix: PLAT and ID: 0523

SNMP Trap ID: 0

Automatically notify Support: No

User response: No action; information only.

81070201-2d01xxxx Sensor [SensorElementName] has transitioned to a less severe state from critical. (IOH Temp Status)

Explanation: This message is for the use case when an implementation has detected a Sensor transition to less severe from critical.

May also be shown as 810702012d01xxxx or 0x810702012d01xxxx

Severity: Info

Alert Category: Critical - Temperature

Serviceable: No

CIM Information: Prefix: PLAT and ID: 0523

SNMP Trap ID: 0

Automatically notify Support: No

User response: No action; information only.

81070202-0701xxxx Sensor [SensorElementName] has transitioned to a less severe state from critical. (Planar Fault)

Explanation: This message is for the use case when an implementation has detected a Sensor transition to less severe from critical.

May also be shown as 810702020701xxxx or 0x810702020701xxxx

Severity: Info

Alert Category: Critical - Voltage

Serviceable: No

CIM Information: Prefix: PLAT and ID: 0523

SNMP Trap ID: 1

Automatically notify Support: No

User response: No action; information only.

81070204-0a01xxxx Sensor [SensorElementName] has transitioned to a less severe state from critical. (PS 1 Fan Fault)

Explanation: This message is for the use case when an implementation has detected a Sensor transition to less severe from critical.

May also be shown as 810702040a01xxxx or 0x810702040a01xxxx

Severity: Info

Alert Category: Critical - Fan Failure

Serviceable: No

CIM Information: Prefix: PLAT and ID: 0523

SNMP Trap ID: 11

Automatically notify Support: No

User response: No action; information only.

81070204-0a02xxxx Sensor [SensorElementName] has transitioned to a less severe state from critical. (PS 2 Fan Fault)

Explanation: This message is for the use case when an implementation has detected a Sensor transition to less severe from critical.

May also be shown as 810702040a02xxxx or 0x810702040a02xxxx

Severity: Info

Alert Category: Critical - Fan Failure

Serviceable: No

CIM Information: Prefix: PLAT and ID: 0523

SNMP Trap ID: 11

Automatically notify Support: No

User response: No action; information only.

81070208-0a01xxxx Sensor [SensorElementName] has transitioned to a less severe state from critical. (PS 1 OP Fault)

Explanation: This message is for the use case when an implementation has detected a Sensor transition to less severe from critical.

May also be shown as 810702080a01xxxx or 0x810702080a01xxxx

Severity: Info

Alert Category: Critical - Power

Serviceable: No

CIM Information: Prefix: PLAT and ID: 0523

SNMP Trap ID: 4

Automatically notify Support: No

User response: No action; information only. PS 1 Therm Fault :

81070208-0a02xxxx Sensor [SensorElementName] has transitioned to a less severe state from critical. (PS 2 OP Fault)

Explanation: This message is for the use case when an implementation has detected a Sensor transition to less severe from critical.

May also be shown as 810702080a02xxxx or 0x810702080a02xxxx

Severity: Info

Alert Category: Critical - Power

Serviceable: No

CIM Information: Prefix: PLAT and ID: 0523

SNMP Trap ID: 4

Automatically notify Support: No

User response: No action; information only. PS 2 Therm Fault :

8107020f-2582xxxx Sensor [SensorElementName] has transitioned to a less severe state from critical. (No I/O Resources)

Explanation: This message is for the use case when an implementation has detected a Sensor transition to less severe from critical.

May also be shown as 8107020f2582xxxx or 0x8107020f2582xxxx

Severity: Info

Alert Category: Critical - Other

Serviceable: No

CIM Information: Prefix: PLAT and ID: 0523

SNMP Trap ID: 50

Automatically notify Support: No

User response: No action; information only.

81070219-0701xxxx Sensor [SensorElementName] has transitioned to a less severe state from critical. (Sys Board Fault)

Explanation: This message is for the use case when an implementation has detected a Sensor transition to less severe from critical.

May also be shown as 810702190701xxxx or 0x810702190701xxxx

Severity: Info

Alert Category: Critical - Other

Serviceable: No

CIM Information: Prefix: PLAT and ID: 0523

SNMP Trap ID: 50

Automatically notify Support: No

User response: No action; information only.

81070301-0301xxxx Sensor [SensorElementName] has deasserted the transition to non-recoverable from a less severe state. (CPU 1 OverTemp)

Explanation: This message is for the use case when an implementation has detected that the Sensor transition to non-recoverable from less severe has deasserted.

May also be shown as 810703010301xxxx or 0x810703010301xxxx

Severity: Info

Alert Category: Critical - Temperature

Serviceable: No

CIM Information: Prefix: PLAT and ID: 0525

SNMP Trap ID: 0

Automatically notify Support: No

User response: No action; information only.

81070301-0302xxxx Sensor [SensorElementName] has deasserted the transition to non-recoverable from a less severe state. (CPU 2 OverTemp)

Explanation: This message is for the use case when an implementation has detected that the Sensor transition to non-recoverable from less severe has deasserted.

May also be shown as 810703010302xxxx or 0x810703010302xxxx

Severity: Info

Alert Category: Critical - Temperature

Serviceable: No

CIM Information: Prefix: PLAT and ID: 0525

SNMP Trap ID: 0

Automatically notify Support: No

User response: No action; information only.

81070301-2d01xxxx Sensor [SensorElementName] has deasserted the transition to non-recoverable from a less severe state. (IOH Temp Status)

Explanation: This message is for the use case when an implementation has detected that the Sensor transition to non-recoverable from less severe has deasserted.

May also be shown as 810703012d01xxxx or 0x810703012d01xxxx

Severity: Info

Alert Category: Critical - Temperature

Serviceable: No

CIM Information: Prefix: PLAT and ID: 0525

SNMP Trap ID: 0

Automatically notify Support: No

User response: No action; information only.

81070603-0701xxxx Sensor [SensorElementName] has deasserted the transition to non-recoverable. (Pwr Rail A Fault)

Explanation: This message is for the use case when an implementation has detected that the Sensor transition to non-recoverable has deasserted.

May also be shown as 810706030701xxxx or 0x810706030701xxxx

Severity: Info

Alert Category: Critical - Power

Serviceable: No

CIM Information: Prefix: PLAT and ID: 0531

SNMP Trap ID: 4

Automatically notify Support: No

User response: No action; information only. Pwr Rail B Fault : Pwr Rail C Fault : Pwr Rail D Fault : Pwr Rail E Fault :

81070608-0701xxxx Sensor [SensorElementName] has deasserted the transition to non-recoverable. (VT Fault)

Explanation: This message is for the use case when an implementation has detected that the Sensor transition to non-recoverable has deasserted.

May also be shown as 810706080701xxxx or 0x810706080701xxxx

Severity: Info

Alert Category: Critical - Power

Serviceable: No

CIM Information: Prefix: PLAT and ID: 0531

SNMP Trap ID: 4

Automatically notify Support: No

User response: No action; information only.

81070608-0a01xxxx • 810b010a-1e81xxxx

81070608-0a01xxxx Sensor [SensorElementName] has deasserted the transition to non-recoverable. (PS 1 VCO Fault)

Explanation: This message is for the use case when an implementation has detected that the Sensor transition to non-recoverable has deasserted.

May also be shown as 810706080a01xxxx or 0x810706080a01xxxx

Severity: Info

Alert Category: Critical - Power

Serviceable: No

CIM Information: Prefix: PLAT and ID: 0531

SNMP Trap ID: 4

Automatically notify Support: No

User response: No action; information only. PS1 12V OC Fault : PS1 12V OV Fault : PS1 12V UV Fault :

81070608-0a02xxxx Sensor [SensorElementName] has deasserted the transition to non-recoverable. (PS 2 VCO Fault)

Explanation: This message is for the use case when an implementation has detected that the Sensor transition to non-recoverable has deasserted.

May also be shown as 810706080a02xxxx or 0x810706080a02xxxx

Severity: Info

Alert Category: Critical - Power

Serviceable: No

CIM Information: Prefix: PLAT and ID: 0531

SNMP Trap ID: 4

Automatically notify Support: No

User response: No action; information only. PS2 12V OC Fault : PS2 12V OV Fault : PS2 12V UV Fault :

810b010a-1e81xxxx Redundancy Lost for [RedundancySetElementName] has deasserted. (Cooling Zone 1)

Explanation: This message is for the use case when Redundancy Lost has deasserted.

May also be shown as 810b010a1e81xxxx or 0x810b010a1e81xxxx

Severity: Info

Alert Category: Critical - Fan Failure

Serviceable: No

CIM Information: Prefix: PLAT and ID: 0803

SNMP Trap ID: 11

Automatically notify Support: No

User response: No action; information only.

810b010a-1e82xxxx Redundancy Lost for [RedundancySetElementName] has deasserted. (Cooling Zone 2)

Explanation: This message is for the use case when Redundancy Lost has deasserted.

May also be shown as 810b010a1e82xxxx or 0x810b010a1e82xxxx

Severity: Info

Alert Category: Critical - Fan Failure

Serviceable: No

CIM Information: Prefix: PLAT and ID: 0803

SNMP Trap ID: 11

Automatically notify Support: No

User response: No action; information only.

810b010a-1e83xxxx Redundancy Lost for [RedundancySetElementName] has deasserted. (Cooling Zone 3)

Explanation: This message is for the use case when Redundancy Lost has deasserted.

May also be shown as 810b010a1e83xxxx or 0x810b010a1e83xxxx

Severity: Info

Alert Category: Critical - Fan Failure

Serviceable: No

CIM Information: Prefix: PLAT and ID: 0803

SNMP Trap ID: 11

Automatically notify Support: No

User response: No action; information only.

810b010c-2581xxxx Redundancy Lost for [RedundancySetElementName] has deasserted. (Backup Memory)

Explanation: This message is for the use case when Redundancy Lost has deasserted.

May also be shown as 810b010c2581xxxx or 0x810b010c2581xxxx

Severity: Info

Alert Category: Critical - Memory

Serviceable: No

CIM Information: Prefix: PLAT and ID: 0803

SNMP Trap ID: 41

Automatically notify Support: No

User response: No action; information only.

810b030c-2581xxxx Non-redundant:Sufficient Resources from Redundancy Degraded or Fully Redundant for [RedundancySetElementName] has deasserted. (Backup Memory)

Explanation: This message is for the use case when a Redundancy Set has transitioned from Non-redundant:Sufficient Resources.

May also be shown as 810b030c2581xxxx or 0x810b030c2581xxxx

Severity: Info

Alert Category: Warning - Memory

Serviceable: No

CIM Information: Prefix: PLAT and ID: 0807

SNMP Trap ID: 43

Automatically notify Support: No

User response: No action; information only.

810b050a-1e81xxxx Non-redundant:Insufficient Resources for [RedundancySetElementName] has deasserted. (Cooling Zone 1)

Explanation: This message is for the use case when a Redundancy Set has transitioned from Non-redundant:Insufficient Resources.

May also be shown as 810b050a1e81xxxx or 0x810b050a1e81xxxx

Severity: Info

Alert Category: Critical - Fan Failure

Serviceable: No

CIM Information: Prefix: PLAT and ID: 0811

SNMP Trap ID: 11

Automatically notify Support: No

User response: No action; information only.

810b050a-1e82xxxx Non-redundant:Insufficient Resources for [RedundancySetElementName] has deasserted. (Cooling Zone 2)

Explanation: This message is for the use case when a Redundancy Set has transitioned from Non-redundant:Insufficient Resources.

May also be shown as 810b050a1e82xxxx or 0x810b050a1e82xxxx

Severity: Info

Alert Category: Critical - Fan Failure

Serviceable: No

CIM Information: Prefix: PLAT and ID: 0811

SNMP Trap ID: 11

Automatically notify Support: No

User response: No action; information only.

**810b050a-1e83xxxx Non-redundant:Insufficient Resources for [RedundancySetElementName] has deasserted.
(Cooling Zone 3)**

Explanation: This message is for the use case when a Redundancy Set has transitioned from Non-redundant:Insufficient Resources.

May also be shown as 810b050a1e83xxxx or 0x810b050a1e83xxxx

Severity: Info

Alert Category: Critical - Fan Failure

Serviceable: No

CIM Information: Prefix: PLAT and ID: 0811

SNMP Trap ID: 11

Automatically notify Support: No

User response: No action; information only.

**810b050c-2581xxxx Non-redundant:Insufficient Resources for [RedundancySetElementName] has deasserted.
(Backup Memory)**

Explanation: This message is for the use case when a Redundancy Set has transitioned from Non-redundant:Insufficient Resources.

May also be shown as 810b050c2581xxxx or 0x810b050c2581xxxx

Severity: Info

Alert Category: Critical - Memory

Serviceable: No

CIM Information: Prefix: PLAT and ID: 0811

SNMP Trap ID: 41

Automatically notify Support: No

User response: No action; information only.

816f0007-0301xxxx [ProcessorElementName] has Recovered from IERR. (CPU 1)

Explanation: This message is for the use case when an implementation has detected a Processor Recovered - IERR Condition.

May also be shown as 816f00070301xxxx or 0x816f00070301xxxx

Severity: Info

Alert Category: Critical - CPU

Serviceable: No

CIM Information: Prefix: PLAT and ID: 0043

SNMP Trap ID: 40

Automatically notify Support: No

User response: No action; information only.

816f0007-0302xxxx • 816f0008-0a02xxxx

816f0007-0302xxxx [ProcessorElementName] has Recovered from IERR. (CPU 2)

Explanation: This message is for the use case when an implementation has detected a Processor Recovered - IERR Condition.

May also be shown as 816f00070302xxxx or 0x816f00070302xxxx

Severity: Info

Alert Category: Critical - CPU

Serviceable: No

CIM Information: Prefix: PLAT and ID: 0043

SNMP Trap ID: 40

Automatically notify Support: No

User response: No action; information only.

816f0008-0a01xxxx [PowerSupplyElementName] has been removed from container
[PhysicalPackageElementName]. (Power Supply 1)

Explanation: This message is for the use case when an implementation has detected a Power Supply has been removed.

May also be shown as 816f00080a01xxxx or 0x816f00080a01xxxx

Severity: Info

Alert Category: System - Other

Serviceable: No

CIM Information: Prefix: PLAT and ID: 0085

SNMP Trap ID:

Automatically notify Support: No

User response: No action; information only.

816f0008-0a02xxxx [PowerSupplyElementName] has been removed from container
[PhysicalPackageElementName]. (Power Supply 2)

Explanation: This message is for the use case when an implementation has detected a Power Supply has been removed.

May also be shown as 816f00080a02xxxx or 0x816f00080a02xxxx

Severity: Info

Alert Category: System - Other

Serviceable: No

CIM Information: Prefix: PLAT and ID: 0085

SNMP Trap ID:

Automatically notify Support: No

User response: No action; information only.

816f0009-1381xxxx [PowerSupplyElementName] has been turned on. (Host Power)

Explanation: This message is for the use case when an implementation has detected a Power Unit that has been Enabled.

May also be shown as 816f00091381xxxx or 0x816f00091381xxxx

Severity: Info

Alert Category: System - Power On

Serviceable: No

CIM Information: Prefix: PLAT and ID: 0107

SNMP Trap ID: 24

Automatically notify Support: No

User response: No action; information only.

816f000d-0400xxxx The Drive [StorageVolumeElementName] has been removed from unit [PhysicalPackageElementName]. (Drive 0)

Explanation: This message is for the use case when an implementation has detected a Drive has been Removed.

May also be shown as 816f000d0400xxxx or 0x816f000d0400xxxx

Severity: Error

Alert Category: Critical - Hard Disk drive

Serviceable: Yes

CIM Information: Prefix: PLAT and ID: 0163

SNMP Trap ID: 5

Automatically notify Support: No

User response: 1. Reseat hard disk drive n.(n = hard disk drive number). Wait 1 minute or more before reinstalling the drive. 2. Replace the hard disk drive. 3. Make sure that the disk firmware and RAID controller firmware is at the latest level. 4. Check the SAS cable.

816f000d-0401xxxx The Drive [StorageVolumeElementName] has been removed from unit [PhysicalPackageElementName]. (Drive 1)

Explanation: This message is for the use case when an implementation has detected a Drive has been Removed.

May also be shown as 816f000d0401xxxx or 0x816f000d0401xxxx

Severity: Error

Alert Category: Critical - Hard Disk drive

Serviceable: Yes

CIM Information: Prefix: PLAT and ID: 0163

SNMP Trap ID: 5

Automatically notify Support: No

User response: 1. Reseat hard disk drive n.(n = hard disk drive number). Wait 1 minute or more before reinstalling the drive. 2. Replace the hard disk drive. 3. Make sure that the disk firmware and RAID controller firmware is at the latest level. 4. Check the SAS cable.

816f000d-0402xxxx The Drive [StorageVolumeElementName] has been removed from unit [PhysicalPackageElementName]. (Drive 2)

Explanation: This message is for the use case when an implementation has detected a Drive has been Removed.

May also be shown as 816f000d0402xxxx or 0x816f000d0402xxxx

Severity: Error

Alert Category: Critical - Hard Disk drive

Serviceable: Yes

CIM Information: Prefix: PLAT and ID: 0163

SNMP Trap ID: 5

Automatically notify Support: No

User response: 1. Reseat hard disk drive n.(n = hard disk drive number). Wait 1 minute or more before reinstalling the drive. 2. Replace the hard disk drive. 3. Make sure that the disk firmware and RAID controller firmware is at the latest level. 4. Check the SAS cable.

816f000d-0403xxxx The Drive [StorageVolumeElementName] has been removed from unit [PhysicalPackageElementName]. (Drive 3)

Explanation: This message is for the use case when an implementation has detected a Drive has been Removed.

May also be shown as 816f000d0403xxxx or 0x816f000d0403xxxx

Severity: Error

Alert Category: Critical - Hard Disk drive

Serviceable: Yes

CIM Information: Prefix: PLAT and ID: 0163

SNMP Trap ID: 5

Automatically notify Support: No

User response: 1. Reseat hard disk drive n.(n = hard disk drive number). Wait 1 minute or more before reinstalling the drive. 2. Replace the hard disk drive. 3. Make sure that the disk firmware and RAID controller firmware is at the latest level. 4. Check the SAS cable.

816f000d-0404xxxx The Drive [StorageVolumeElementName] has been removed from unit [PhysicalPackageElementName]. (Drive 4)

Explanation: This message is for the use case when an implementation has detected a Drive has been Removed.

May also be shown as 816f000d0404xxxx or 0x816f000d0404xxxx

Severity: Error

Alert Category: Critical - Hard Disk drive

Serviceable: Yes

CIM Information: Prefix: PLAT and ID: 0163

SNMP Trap ID: 5

Automatically notify Support: No

User response: 1. Reseat hard disk drive n.(n = hard disk drive number). Wait 1 minute or more before reinstalling the drive. 2. Replace the hard disk drive. 3. Make sure that the disk firmware and RAID controller firmware is at the latest level. 4. Check the SAS cable.

816f000d-0405xxxx The Drive [StorageVolumeElementName] has been removed from unit [PhysicalPackageElementName]. (Drive 5)

Explanation: This message is for the use case when an implementation has detected a Drive has been Removed.

May also be shown as 816f000d0405xxxx or 0x816f000d0405xxxx

Severity: Error

Alert Category: Critical - Hard Disk drive

Serviceable: Yes

CIM Information: Prefix: PLAT and ID: 0163

SNMP Trap ID: 5

Automatically notify Support: No

User response: 1. Reseat hard disk drive n.(n = hard disk drive number). Wait 1 minute or more before reinstalling the drive. 2. Replace the hard disk drive. 3. Make sure that the disk firmware and RAID controller firmware is at the latest level. 4. Check the SAS cable.

816f000d-0406xxxx The Drive [StorageVolumeElementName] has been removed from unit [PhysicalPackageElementName]. (Drive 6)

Explanation: This message is for the use case when an implementation has detected a Drive has been Removed.

May also be shown as 816f000d0406xxxx or 0x816f000d0406xxxx

Severity: Error

Alert Category: Critical - Hard Disk drive

Serviceable: Yes

CIM Information: Prefix: PLAT and ID: 0163

SNMP Trap ID: 5

Automatically notify Support: No

User response: 1. Reseat hard disk drive n.(n = hard disk drive number). Wait 1 minute or more before reinstalling the drive. 2. Replace the hard disk drive. 3. Make sure that the disk firmware and RAID controller firmware is at the latest level. 4. Check the SAS cable.

816f000d-0407xxxx The Drive [StorageVolumeElementName] has been removed from unit [PhysicalPackageElementName]. (Drive 7)

Explanation: This message is for the use case when an implementation has detected a Drive has been Removed.

May also be shown as 816f000d0407xxxx or 0x816f000d0407xxxx

Severity: Error

Alert Category: Critical - Hard Disk drive

Serviceable: Yes

CIM Information: Prefix: PLAT and ID: 0163

SNMP Trap ID: 5

Automatically notify Support: No

User response: 1. Reseat hard disk drive n.(n = hard disk drive number). Wait 1 minute or more before reinstalling the drive. 2. Replace the hard disk drive. 3. Make sure that the disk firmware and RAID controller firmware is at the latest level. 4. Check the SAS cable.

816f000f-2201ffff • 816f0021-2201xxxx

816f000f-2201ffff The System [ComputerSystemElementName] has detected a POST Error deassertion. (ABR Status)

Explanation: This message is for the use case when an implementation has detected that Post Error has deasserted.

May also be shown as 816f000f2201ffff or 0x816f000f2201ffff

Severity: Info

Alert Category: Critical - Other

Serviceable: No

CIM Information: Prefix: PLAT and ID: 0185

SNMP Trap ID: 50

Automatically notify Support: No

User response: No action; information only. Firmware Error :

816f0013-1701xxxx System [ComputerSystemElementName] has recovered from a diagnostic interrupt. (NMI State)

Explanation: This message is for the use case when an implementation has detected a recovery from a Front Panel NMI / Diagnostic Interrupt

May also be shown as 816f00131701xxxx or 0x816f00131701xxxx

Severity: Info

Alert Category: Critical - Other

Serviceable: No

CIM Information: Prefix: PLAT and ID: 0223

SNMP Trap ID: 50

Automatically notify Support: No

User response: No action; information only.

816f0021-2201xxxx Fault condition removed on slot [PhysicalConnectorElementName] on system [ComputerSystemElementName]. (No Op ROM Space)

Explanation: This message is for the use case when an implementation has detected a Fault condition in a slot has been removed.

May also be shown as 816f00212201xxxx or 0x816f00212201xxxx

Severity: Info

Alert Category: Critical - Other

Serviceable: No

CIM Information: Prefix: PLAT and ID: 0331

SNMP Trap ID: 50

Automatically notify Support: No

User response: No action; information only.

816f0021-2582xxxx Fault condition removed on slot [PhysicalConnectorElementName] on system [ComputerSystemElementName]. (All PCI Error)

Explanation: This message is for the use case when an implementation has detected a Fault condition in a slot has been removed.

May also be shown as 816f00212582xxxx or 0x816f00212582xxxx

Severity: Info

Alert Category: Critical - Other

Serviceable: No

CIM Information: Prefix: PLAT and ID: 0331

SNMP Trap ID: 50

Automatically notify Support: No

User response: No action; information only. One of PCI Error :

816f0021-3001xxxx Fault condition removed on slot [PhysicalConnectorElementName] on system [ComputerSystemElementName]. (PCI 1)

Explanation: This message is for the use case when an implementation has detected a Fault condition in a slot has been removed.

May also be shown as 816f00213001xxxx or 0x816f00213001xxxx

Severity: Info

Alert Category: Critical - Other

Serviceable: No

CIM Information: Prefix: PLAT and ID: 0331

SNMP Trap ID: 50

Automatically notify Support: No

User response: No action; information only. PCI 2 : PCI 5 :

816f0107-0301xxxx An Over-Temperature Condition has been removed on [ProcessorElementName]. (CPU 1)

Explanation: This message is for the use case when an implementation has detected a Over-Temperature Condition has been Removed for Processor.

May also be shown as 816f01070301xxxx or 0x816f01070301xxxx

Severity: Info

Alert Category: Critical - Temperature

Serviceable: No

CIM Information: Prefix: PLAT and ID: 0037

SNMP Trap ID: 0

Automatically notify Support: No

User response: No action; information only.

816f0107-0302xxxx An Over-Temperature Condition has been removed on [ProcessorElementName]. (CPU 2)

Explanation: This message is for the use case when an implementation has detected a Over-Temperature Condition has been Removed for Processor.

May also be shown as 816f01070302xxxx or 0x816f01070302xxxx

Severity: Info

Alert Category: Critical - Temperature

Serviceable: No

CIM Information: Prefix: PLAT and ID: 0037

SNMP Trap ID: 0

Automatically notify Support: No

User response: No action; information only.

816f0108-0a01xxxx [PowerSupplyElementName] has returned to OK status. (Power Supply 1)

Explanation: This message is for the use case when an implementation has detected a Power Supply return to normal operational status.

May also be shown as 816f01080a01xxxx or 0x816f01080a01xxxx

Severity: Info

Alert Category: Critical - Power

Serviceable: No

CIM Information: Prefix: PLAT and ID: 0087

SNMP Trap ID: 4

Automatically notify Support: No

User response: No action; information only.

816f0108-0a02xxxx [PowerSupplyElementName] has returned to OK status. (Power Supply 2)

Explanation: This message is for the use case when an implementation has detected a Power Supply return to normal operational status.

May also be shown as 816f01080a02xxxx or 0x816f01080a02xxxx

Severity: Info

Alert Category: Critical - Power

Serviceable: No

CIM Information: Prefix: PLAT and ID: 0087

SNMP Trap ID: 4

Automatically notify Support: No

User response: No action; information only.

816f010c-2001xxxx Uncorrectable error recovery detected for [PhysicalMemoryElementName] on Subsystem [MemoryElementName]. (DIMM 1)

Explanation: This message is for the use case when an implementation has detected a Memory uncorrectable error recovery.

May also be shown as 816f010c2001xxxx or 0x816f010c2001xxxx

Severity: Info

Alert Category: Critical - Memory

Serviceable: No

CIM Information: Prefix: PLAT and ID: 0139

SNMP Trap ID: 41

Automatically notify Support: No

User response: No action; information only.

816f010c-2002xxxx Uncorrectable error recovery detected for [PhysicalMemoryElementName] on Subsystem [MemoryElementName]. (DIMM 2)

Explanation: This message is for the use case when an implementation has detected a Memory uncorrectable error recovery.

May also be shown as 816f010c2002xxxx or 0x816f010c2002xxxx

Severity: Info

Alert Category: Critical - Memory

Serviceable: No

CIM Information: Prefix: PLAT and ID: 0139

SNMP Trap ID: 41

Automatically notify Support: No

User response: No action; information only.

816f010c-2003xxxx Uncorrectable error recovery detected for [PhysicalMemoryElementName] on Subsystem [MemoryElementName]. (DIMM 3)

Explanation: This message is for the use case when an implementation has detected a Memory uncorrectable error recovery.

May also be shown as 816f010c2003xxxx or 0x816f010c2003xxxx

Severity: Info

Alert Category: Critical - Memory

Serviceable: No

CIM Information: Prefix: PLAT and ID: 0139

SNMP Trap ID: 41

Automatically notify Support: No

User response: No action; information only.

816f010c-2004xxxx Uncorrectable error recovery detected for [PhysicalMemoryElementName] on Subsystem [MemoryElementName]. (DIMM 4)

Explanation: This message is for the use case when an implementation has detected a Memory uncorrectable error recovery.

May also be shown as 816f010c2004xxxx or 0x816f010c2004xxxx

Severity: Info

Alert Category: Critical - Memory

Serviceable: No

CIM Information: Prefix: PLAT and ID: 0139

SNMP Trap ID: 41

Automatically notify Support: No

User response: No action; information only.

816f010c-2005xxxx Uncorrectable error recovery detected for [PhysicalMemoryElementName] on Subsystem [MemoryElementName]. (DIMM 5)

Explanation: This message is for the use case when an implementation has detected a Memory uncorrectable error recovery.

May also be shown as 816f010c2005xxxx or 0x816f010c2005xxxx

Severity: Info

Alert Category: Critical - Memory

Serviceable: No

CIM Information: Prefix: PLAT and ID: 0139

SNMP Trap ID: 41

Automatically notify Support: No

User response: No action; information only.

816f010c-2006xxxx Uncorrectable error recovery detected for [PhysicalMemoryElementName] on Subsystem [MemoryElementName]. (DIMM 6)

Explanation: This message is for the use case when an implementation has detected a Memory uncorrectable error recovery.

May also be shown as 816f010c2006xxxx or 0x816f010c2006xxxx

Severity: Info

Alert Category: Critical - Memory

Serviceable: No

CIM Information: Prefix: PLAT and ID: 0139

SNMP Trap ID: 41

Automatically notify Support: No

User response: No action; information only.

816f010c-2007xxxx Uncorrectable error recovery detected for [PhysicalMemoryElementName] on Subsystem [MemoryElementName]. (DIMM 7)

Explanation: This message is for the use case when an implementation has detected a Memory uncorrectable error recovery.

May also be shown as 816f010c2007xxxx or 0x816f010c2007xxxx

Severity: Info

Alert Category: Critical - Memory

Serviceable: No

CIM Information: Prefix: PLAT and ID: 0139

SNMP Trap ID: 41

Automatically notify Support: No

User response: No action; information only.

816f010c-2008xxxx Uncorrectable error recovery detected for [PhysicalMemoryElementName] on Subsystem [MemoryElementName]. (DIMM 8)

Explanation: This message is for the use case when an implementation has detected a Memory uncorrectable error recovery.

May also be shown as 816f010c2008xxxx or 0x816f010c2008xxxx

Severity: Info

Alert Category: Critical - Memory

Serviceable: No

CIM Information: Prefix: PLAT and ID: 0139

SNMP Trap ID: 41

Automatically notify Support: No

User response: No action; information only.

816f010c-2009xxxx Uncorrectable error recovery detected for [PhysicalMemoryElementName] on Subsystem [MemoryElementName]. (DIMM 9)

Explanation: This message is for the use case when an implementation has detected a Memory uncorrectable error recovery.

May also be shown as 816f010c2009xxxx or 0x816f010c2009xxxx

Severity: Info

Alert Category: Critical - Memory

Serviceable: No

CIM Information: Prefix: PLAT and ID: 0139

SNMP Trap ID: 41

Automatically notify Support: No

User response: No action; information only.

816f010c-200axxxx • 816f010c-200cxxxx

816f010c-200axxxx Uncorrectable error recovery detected for [PhysicalMemoryElementName] on Subsystem [MemoryElementName]. (DIMM 10)

Explanation: This message is for the use case when an implementation has detected a Memory uncorrectable error recovery.

May also be shown as 816f010c200axxxx or 0x816f010c200axxxx

Severity: Info

Alert Category: Critical - Memory

Serviceable: No

CIM Information: Prefix: PLAT and ID: 0139

SNMP Trap ID: 41

Automatically notify Support: No

User response: No action; information only.

816f010c-200bxxxx Uncorrectable error recovery detected for [PhysicalMemoryElementName] on Subsystem [MemoryElementName]. (DIMM 11)

Explanation: This message is for the use case when an implementation has detected a Memory uncorrectable error recovery.

May also be shown as 816f010c200bxxxx or 0x816f010c200bxxxx

Severity: Info

Alert Category: Critical - Memory

Serviceable: No

CIM Information: Prefix: PLAT and ID: 0139

SNMP Trap ID: 41

Automatically notify Support: No

User response: No action; information only.

816f010c-200cxxxx Uncorrectable error recovery detected for [PhysicalMemoryElementName] on Subsystem [MemoryElementName]. (DIMM 12)

Explanation: This message is for the use case when an implementation has detected a Memory uncorrectable error recovery.

May also be shown as 816f010c200cxxxx or 0x816f010c200cxxxx

Severity: Info

Alert Category: Critical - Memory

Serviceable: No

CIM Information: Prefix: PLAT and ID: 0139

SNMP Trap ID: 41

Automatically notify Support: No

User response: No action; information only.

816f010c-200dxxxx Uncorrectable error recovery detected for [PhysicalMemoryElementName] on Subsystem [MemoryElementName]. (DIMM 13)

Explanation: This message is for the use case when an implementation has detected a Memory uncorrectable error recovery.

May also be shown as 816f010c200dxxxx or 0x816f010c200dxxxx

Severity: Info

Alert Category: Critical - Memory

Serviceable: No

CIM Information: Prefix: PLAT and ID: 0139

SNMP Trap ID: 41

Automatically notify Support: No

User response: No action; information only.

816f010c-200exxxx Uncorrectable error recovery detected for [PhysicalMemoryElementName] on Subsystem [MemoryElementName]. (DIMM 14)

Explanation: This message is for the use case when an implementation has detected a Memory uncorrectable error recovery.

May also be shown as 816f010c200exxxx or 0x816f010c200exxxx

Severity: Info

Alert Category: Critical - Memory

Serviceable: No

CIM Information: Prefix: PLAT and ID: 0139

SNMP Trap ID: 41

Automatically notify Support: No

User response: No action; information only.

816f010c-200fxxxx Uncorrectable error recovery detected for [PhysicalMemoryElementName] on Subsystem [MemoryElementName]. (DIMM 15)

Explanation: This message is for the use case when an implementation has detected a Memory uncorrectable error recovery.

May also be shown as 816f010c200fxxxx or 0x816f010c200fxxxx

Severity: Info

Alert Category: Critical - Memory

Serviceable: No

CIM Information: Prefix: PLAT and ID: 0139

SNMP Trap ID: 41

Automatically notify Support: No

User response: No action; information only.

816f010c-2010xxxx Uncorrectable error recovery detected for [PhysicalMemoryElementName] on Subsystem [MemoryElementName]. (DIMM 16)

Explanation: This message is for the use case when an implementation has detected a Memory uncorrectable error recovery.

May also be shown as 816f010c2010xxxx or 0x816f010c2010xxxx

Severity: Info

Alert Category: Critical - Memory

Serviceable: No

CIM Information: Prefix: PLAT and ID: 0139

SNMP Trap ID: 41

Automatically notify Support: No

User response: No action; information only.

816f010c-2011xxxx Uncorrectable error recovery detected for [PhysicalMemoryElementName] on Subsystem [MemoryElementName]. (DIMM 17)

Explanation: This message is for the use case when an implementation has detected a Memory uncorrectable error recovery.

May also be shown as 816f010c2011xxxx or 0x816f010c2011xxxx

Severity: Info

Alert Category: Critical - Memory

Serviceable: No

CIM Information: Prefix: PLAT and ID: 0139

SNMP Trap ID: 41

Automatically notify Support: No

User response: No action; information only.

816f010c-2012xxxx Uncorrectable error recovery detected for [PhysicalMemoryElementName] on Subsystem [MemoryElementName]. (DIMM 18)

Explanation: This message is for the use case when an implementation has detected a Memory uncorrectable error recovery.

May also be shown as 816f010c2012xxxx or 0x816f010c2012xxxx

Severity: Info

Alert Category: Critical - Memory

Serviceable: No

CIM Information: Prefix: PLAT and ID: 0139

SNMP Trap ID: 41

Automatically notify Support: No

User response: No action; information only.

816f010c-2581xxxx Uncorrectable error recovery detected for [PhysicalMemoryElementName] on Subsystem [MemoryElementName]. (All DIMMS)

Explanation: This message is for the use case when an implementation has detected a Memory uncorrectable error recovery.

May also be shown as 816f010c2581xxxx or 0x816f010c2581xxxx

Severity: Info

Alert Category: Critical - Memory

Serviceable: No

CIM Information: Prefix: PLAT and ID: 0139

SNMP Trap ID: 41

Automatically notify Support: No

User response: No action; information only. One of the DIMMs :

816f010d-0400xxxx The Drive [StorageVolumeElementName] has been enabled. (Drive 0)

Explanation: This message is for the use case when an implementation has detected a Drive was Enabled.

May also be shown as 816f010d0400xxxx or 0x816f010d0400xxxx

Severity: Info

Alert Category: Critical - Hard Disk drive

Serviceable: No

CIM Information: Prefix: PLAT and ID: 0167

SNMP Trap ID: 5

Automatically notify Support: No

User response: No action; information only.

816f010d-0401xxxx The Drive [StorageVolumeElementName] has been enabled. (Drive 1)

Explanation: This message is for the use case when an implementation has detected a Drive was Enabled.

May also be shown as 816f010d0401xxxx or 0x816f010d0401xxxx

Severity: Info

Alert Category: Critical - Hard Disk drive

Serviceable: No

CIM Information: Prefix: PLAT and ID: 0167

SNMP Trap ID: 5

Automatically notify Support: No

User response: No action; information only.

816f010d-0402xxxx The Drive [StorageVolumeElementName] has been enabled. (Drive 2)

Explanation: This message is for the use case when an implementation has detected a Drive was Enabled.

May also be shown as 816f010d0402xxxx or 0x816f010d0402xxxx

Severity: Info

Alert Category: Critical - Hard Disk drive

Serviceable: No

CIM Information: Prefix: PLAT and ID: 0167

SNMP Trap ID: 5

Automatically notify Support: No

User response: No action; information only.

816f010d-0403xxxx The Drive [StorageVolumeElementName] has been enabled. (Drive 3)

Explanation: This message is for the use case when an implementation has detected a Drive was Enabled.

May also be shown as 816f010d0403xxxx or 0x816f010d0403xxxx

Severity: Info

Alert Category: Critical - Hard Disk drive

Serviceable: No

CIM Information: Prefix: PLAT and ID: 0167

SNMP Trap ID: 5

Automatically notify Support: No

User response: No action; information only.

816f010d-0404xxxx The Drive [StorageVolumeElementName] has been enabled. (Drive 4)

Explanation: This message is for the use case when an implementation has detected a Drive was Enabled.

May also be shown as 816f010d0404xxxx or 0x816f010d0404xxxx

Severity: Info

Alert Category: Critical - Hard Disk drive

Serviceable: No

CIM Information: Prefix: PLAT and ID: 0167

SNMP Trap ID: 5

Automatically notify Support: No

User response: No action; information only.

816f010d-0405xxxx The Drive [StorageVolumeElementName] has been enabled. (Drive 5)

Explanation: This message is for the use case when an implementation has detected a Drive was Enabled.

May also be shown as 816f010d0405xxxx or 0x816f010d0405xxxx

Severity: Info

Alert Category: Critical - Hard Disk drive

Serviceable: No

CIM Information: Prefix: PLAT and ID: 0167

SNMP Trap ID: 5

Automatically notify Support: No

User response: No action; information only.

816f010d-0406xxxx The Drive [StorageVolumeElementName] has been enabled. (Drive 6)

Explanation: This message is for the use case when an implementation has detected a Drive was Enabled.

May also be shown as 816f010d0406xxxx or 0x816f010d0406xxxx

Severity: Info

Alert Category: Critical - Hard Disk drive

Serviceable: No

CIM Information: Prefix: PLAT and ID: 0167

SNMP Trap ID: 5

Automatically notify Support: No

User response: No action; information only.

816f010d-0407xxxx The Drive [StorageVolumeElementName] has been enabled. (Drive 7)

Explanation: This message is for the use case when an implementation has detected a Drive was Enabled.

May also be shown as 816f010d0407xxxx or 0x816f010d0407xxxx

Severity: Info

Alert Category: Critical - Hard Disk drive

Serviceable: No

CIM Information: Prefix: PLAT and ID: 0167

SNMP Trap ID: 5

Automatically notify Support: No

User response: No action; information only.

816f010f-2201xxxx • 816f0125-0b01xxxx

816f010f-2201xxxx The System [ComputerSystemElementName] has recovered from a firmware hang. (Firmware Error)

Explanation: This message is for the use case when an implementation has recovered from a System Firmware Hang.

May also be shown as 816f010f2201xxxx or 0x816f010f2201xxxx

Severity: Info

Alert Category: Critical - Other

Serviceable: No

CIM Information: Prefix: PLAT and ID: 0187

SNMP Trap ID: 50

Automatically notify Support: No

User response: No action; information only.

816f011b-0701xxxx The connector [PhysicalConnectorElementName] configuration error has been repaired. (Video USB)

Explanation: This message is for the use case when an implementation has detected an Interconnect Configuration was Repaired.

May also be shown as 816f011b0701xxxx or 0x816f011b0701xxxx

Severity: Info

Alert Category: Critical - Other

Serviceable: No

CIM Information: Prefix: PLAT and ID: 0267

SNMP Trap ID: 50

Automatically notify Support: No

User response: No action; information only.

816f0125-0b01xxxx [ManagedElementName] detected as present. (SAS Riser)

Explanation: This message is for the use case when an implementation has detected a Managed Element is now Present.

May also be shown as 816f01250b01xxxx or 0x816f01250b01xxxx

Severity: Info

Alert Category: System - Other

Serviceable: No

CIM Information: Prefix: PLAT and ID: 0390

SNMP Trap ID:

Automatically notify Support: No

User response: No action; information only.

816f0125-0b02xxxx [ManagedElementName] detected as present. (PCI Riser 1)

Explanation: This message is for the use case when an implementation has detected a Managed Element is now Present.

May also be shown as 816f01250b02xxxx or 0x816f01250b02xxxx

Severity: Info

Alert Category: System - Other

Serviceable: No

CIM Information: Prefix: PLAT and ID: 0390

SNMP Trap ID:

Automatically notify Support: No

User response: No action; information only.

816f0125-0b03xxxx [ManagedElementName] detected as present. (PCI Riser 2)

Explanation: This message is for the use case when an implementation has detected a Managed Element is now Present.

May also be shown as 816f01250b03xxxx or 0x816f01250b03xxxx

Severity: Info

Alert Category: System - Other

Serviceable: No

CIM Information: Prefix: PLAT and ID: 0390

SNMP Trap ID:

Automatically notify Support: No

User response: No action; information only.

816f0125-0c01xxxx [ManagedElementName] detected as present. (Front Panel)

Explanation: This message is for the use case when an implementation has detected a Managed Element is now Present.

May also be shown as 816f01250c01xxxx or 0x816f01250c01xxxx

Severity: Info

Alert Category: System - Other

Serviceable: No

CIM Information: Prefix: PLAT and ID: 0390

SNMP Trap ID:

Automatically notify Support: No

User response: No action; information only.

816f0125-1d01xxxx • 816f0125-1d03xxxx

816f0125-1d01xxxx [ManagedElementName] detected as present. (Fan 1)

Explanation: This message is for the use case when an implementation has detected a Managed Element is now Present.

May also be shown as 816f01251d01xxxx or 0x816f01251d01xxxx

Severity: Info

Alert Category: System - Other

Serviceable: No

CIM Information: Prefix: PLAT and ID: 0390

SNMP Trap ID:

Automatically notify Support: No

User response: No action; information only.

816f0125-1d02xxxx [ManagedElementName] detected as present. (Fan 2)

Explanation: This message is for the use case when an implementation has detected a Managed Element is now Present.

May also be shown as 816f01251d02xxxx or 0x816f01251d02xxxx

Severity: Info

Alert Category: System - Other

Serviceable: No

CIM Information: Prefix: PLAT and ID: 0390

SNMP Trap ID:

Automatically notify Support: No

User response: No action; information only.

816f0125-1d03xxxx [ManagedElementName] detected as present. (Fan 3)

Explanation: This message is for the use case when an implementation has detected a Managed Element is now Present.

May also be shown as 816f01251d03xxxx or 0x816f01251d03xxxx

Severity: Info

Alert Category: System - Other

Serviceable: No

CIM Information: Prefix: PLAT and ID: 0390

SNMP Trap ID:

Automatically notify Support: No

User response: No action; information only.

816f0125-1d04xxxx [ManagedElementName] detected as present. (Fan 4)

Explanation: This message is for the use case when an implementation has detected a Managed Element is now Present.

May also be shown as 816f01251d04xxxx or 0x816f01251d04xxxx

Severity: Info

Alert Category: System - Other

Serviceable: No

CIM Information: Prefix: PLAT and ID: 0390

SNMP Trap ID:

Automatically notify Support: No

User response: No action; information only.

816f0125-1d05xxxx [ManagedElementName] detected as present. (Fan 5)

Explanation: This message is for the use case when an implementation has detected a Managed Element is now Present.

May also be shown as 816f01251d05xxxx or 0x816f01251d05xxxx

Severity: Info

Alert Category: System - Other

Serviceable: No

CIM Information: Prefix: PLAT and ID: 0390

SNMP Trap ID:

Automatically notify Support: No

User response: No action; information only.

816f0125-1d06xxxx [ManagedElementName] detected as present. (Fan 6)

Explanation: This message is for the use case when an implementation has detected a Managed Element is now Present.

May also be shown as 816f01251d06xxxx or 0x816f01251d06xxxx

Severity: Info

Alert Category: System - Other

Serviceable: No

CIM Information: Prefix: PLAT and ID: 0390

SNMP Trap ID:

Automatically notify Support: No

User response: No action; information only.

816f0207-0301xxxx [ProcessorElementName] has Recovered from FRB1/BIST condition. (CPU 1)

Explanation: This message is for the use case when an implementation has detected a Processor Recovered - FRB1/BIST condition.

May also be shown as 816f02070301xxxx or 0x816f02070301xxxx

Severity: Info

Alert Category: Critical - CPU

Serviceable: No

CIM Information: Prefix: PLAT and ID: 0045

SNMP Trap ID: 40

Automatically notify Support: No

User response: No action; information only.

816f0207-0302xxxx [ProcessorElementName] has Recovered from FRB1/BIST condition. (CPU 2)

Explanation: This message is for the use case when an implementation has detected a Processor Recovered - FRB1/BIST condition.

May also be shown as 816f02070302xxxx or 0x816f02070302xxxx

Severity: Info

Alert Category: Critical - CPU

Serviceable: No

CIM Information: Prefix: PLAT and ID: 0045

SNMP Trap ID: 40

Automatically notify Support: No

User response: No action; information only.

816f020d-0400xxxx Failure no longer Predicted on drive [StorageVolumeElementName] for array [ComputerSystemElementName]. (Drive 0)

Explanation: This message is for the use case when an implementation has detected an Array Failure is no longer Predicted.

May also be shown as 816f020d0400xxxx or 0x816f020d0400xxxx

Severity: Info

Alert Category: System - Predicted Failure

Serviceable: No

CIM Information: Prefix: PLAT and ID: 0169

SNMP Trap ID: 27

Automatically notify Support: No

User response: No action; information only.

816f020d-0401xxxx Failure no longer Predicted on drive [StorageVolumeElementName] for array [ComputerSystemElementName]. (Drive 1)

Explanation: This message is for the use case when an implementation has detected an Array Failure is no longer Predicted.

May also be shown as 816f020d0401xxxx or 0x816f020d0401xxxx

Severity: Info

Alert Category: System - Predicted Failure

Serviceable: No

CIM Information: Prefix: PLAT and ID: 0169

SNMP Trap ID: 27

Automatically notify Support: No

User response: No action; information only.

816f020d-0402xxxx Failure no longer Predicted on drive [StorageVolumeElementName] for array [ComputerSystemElementName]. (Drive 2)

Explanation: This message is for the use case when an implementation has detected an Array Failure is no longer Predicted.

May also be shown as 816f020d0402xxxx or 0x816f020d0402xxxx

Severity: Info

Alert Category: System - Predicted Failure

Serviceable: No

CIM Information: Prefix: PLAT and ID: 0169

SNMP Trap ID: 27

Automatically notify Support: No

User response: No action; information only.

816f020d-0403xxxx Failure no longer Predicted on drive [StorageVolumeElementName] for array [ComputerSystemElementName]. (Drive 3)

Explanation: This message is for the use case when an implementation has detected an Array Failure is no longer Predicted.

May also be shown as 816f020d0403xxxx or 0x816f020d0403xxxx

Severity: Info

Alert Category: System - Predicted Failure

Serviceable: No

CIM Information: Prefix: PLAT and ID: 0169

SNMP Trap ID: 27

Automatically notify Support: No

User response: No action; information only.

816f020d-0404xxxx • 816f020d-0406xxxx

816f020d-0404xxxx Failure no longer Predicted on drive [StorageVolumeElementName] for array [ComputerSystemElementName]. (Drive 4)

Explanation: This message is for the use case when an implementation has detected an Array Failure is no longer Predicted.

May also be shown as 816f020d0404xxxx or 0x816f020d0404xxxx

Severity: Info

Alert Category: System - Predicted Failure

Serviceable: No

CIM Information: Prefix: PLAT and ID: 0169

SNMP Trap ID: 27

Automatically notify Support: No

User response: No action; information only.

816f020d-0405xxxx Failure no longer Predicted on drive [StorageVolumeElementName] for array [ComputerSystemElementName]. (Drive 5)

Explanation: This message is for the use case when an implementation has detected an Array Failure is no longer Predicted.

May also be shown as 816f020d0405xxxx or 0x816f020d0405xxxx

Severity: Info

Alert Category: System - Predicted Failure

Serviceable: No

CIM Information: Prefix: PLAT and ID: 0169

SNMP Trap ID: 27

Automatically notify Support: No

User response: No action; information only.

816f020d-0406xxxx Failure no longer Predicted on drive [StorageVolumeElementName] for array [ComputerSystemElementName]. (Drive 6)

Explanation: This message is for the use case when an implementation has detected an Array Failure is no longer Predicted.

May also be shown as 816f020d0406xxxx or 0x816f020d0406xxxx

Severity: Info

Alert Category: System - Predicted Failure

Serviceable: No

CIM Information: Prefix: PLAT and ID: 0169

SNMP Trap ID: 27

Automatically notify Support: No

User response: No action; information only.

816f020d-0407xxxx Failure no longer Predicted on drive [StorageVolumeElementName] for array [ComputerSystemElementName]. (Drive 7)

Explanation: This message is for the use case when an implementation has detected an Array Failure is no longer Predicted.

May also be shown as 816f020d0407xxxx or 0x816f020d0407xxxx

Severity: Info

Alert Category: System - Predicted Failure

Serviceable: No

CIM Information: Prefix: PLAT and ID: 0169

SNMP Trap ID: 27

Automatically notify Support: No

User response: No action; information only.

816f0212-2584xxxx The System [ComputerSystemElementName] has recovered from an unknown system hardware fault. (CPU Fault Reboot)

Explanation: This message is for the use case when an implementation has recovered from an Unknown System Hardware Failure.

May also be shown as 816f02122584xxxx or 0x816f02122584xxxx

Severity: Info

Alert Category: Critical - Other

Serviceable: No

CIM Information: Prefix: PLAT and ID: 0215

SNMP Trap ID: 50

Automatically notify Support: No

User response: No action; information only.

816f0308-0a01xxxx [PowerSupplyElementName] has returned to a Normal Input State. (Power Supply 1)

Explanation: This message is for the use case when an implementation has detected a Power Supply that has input that has returned to normal.

May also be shown as 816f03080a01xxxx or 0x816f03080a01xxxx

Severity: Info

Alert Category: System - Other

Serviceable: No

CIM Information: Prefix: PLAT and ID: 0099

SNMP Trap ID:

Automatically notify Support: No

User response: No action; information only.

816f0308-0a02xxxx [PowerSupplyElementName] has returned to a Normal Input State. (Power Supply 2)

Explanation: This message is for the use case when an implementation has detected a Power Supply that has input that has returned to normal.

May also be shown as 816f03080a02xxxx or 0x816f03080a02xxxx

Severity: Info

Alert Category: System - Other

Serviceable: No

CIM Information: Prefix: PLAT and ID: 0099

SNMP Trap ID:

Automatically notify Support: No

User response: No action; information only.

816f030c-2001xxxx Scrub Failure for [PhysicalMemoryElementName] on Subsystem [MemoryElementName]has recovered. (DIMM 1)

Explanation: This message is for the use case when an implementation has detected a Memory Scrub failure recovery.

May also be shown as 816f030c2001xxxx or 0x816f030c2001xxxx

Severity: Info

Alert Category: Critical - Memory

Serviceable: No

CIM Information: Prefix: PLAT and ID: 0137

SNMP Trap ID: 41

Automatically notify Support: No

User response: No action; information only.

816f030c-2002xxxx Scrub Failure for [PhysicalMemoryElementName] on Subsystem [MemoryElementName]has recovered. (DIMM 2)

Explanation: This message is for the use case when an implementation has detected a Memory Scrub failure recovery.

May also be shown as 816f030c2002xxxx or 0x816f030c2002xxxx

Severity: Info

Alert Category: Critical - Memory

Serviceable: No

CIM Information: Prefix: PLAT and ID: 0137

SNMP Trap ID: 41

Automatically notify Support: No

User response: No action; information only.

816f030c-2003xxxx Scrub Failure for [PhysicalMemoryElementName] on Subsystem [MemoryElementName]has recovered. (DIMM 3)

Explanation: This message is for the use case when an implementation has detected a Memory Scrub failure recovery.

May also be shown as 816f030c2003xxxx or 0x816f030c2003xxxx

Severity: Info

Alert Category: Critical - Memory

Serviceable: No

CIM Information: Prefix: PLAT and ID: 0137

SNMP Trap ID: 41

Automatically notify Support: No

User response: No action; information only.

816f030c-2004xxxx Scrub Failure for [PhysicalMemoryElementName] on Subsystem [MemoryElementName]has recovered. (DIMM 4)

Explanation: This message is for the use case when an implementation has detected a Memory Scrub failure recovery.

May also be shown as 816f030c2004xxxx or 0x816f030c2004xxxx

Severity: Info

Alert Category: Critical - Memory

Serviceable: No

CIM Information: Prefix: PLAT and ID: 0137

SNMP Trap ID: 41

Automatically notify Support: No

User response: No action; information only.

816f030c-2005xxxx Scrub Failure for [PhysicalMemoryElementName] on Subsystem [MemoryElementName]has recovered. (DIMM 5)

Explanation: This message is for the use case when an implementation has detected a Memory Scrub failure recovery.

May also be shown as 816f030c2005xxxx or 0x816f030c2005xxxx

Severity: Info

Alert Category: Critical - Memory

Serviceable: No

CIM Information: Prefix: PLAT and ID: 0137

SNMP Trap ID: 41

Automatically notify Support: No

User response: No action; information only.

816f030c-2006xxxx Scrub Failure for [PhysicalMemoryElementName] on Subsystem [MemoryElementName]has recovered. (DIMM 6)

Explanation: This message is for the use case when an implementation has detected a Memory Scrub failure recovery.

May also be shown as 816f030c2006xxxx or 0x816f030c2006xxxx

Severity: Info

Alert Category: Critical - Memory

Serviceable: No

CIM Information: Prefix: PLAT and ID: 0137

SNMP Trap ID: 41

Automatically notify Support: No

User response: No action; information only.

816f030c-2007xxxx Scrub Failure for [PhysicalMemoryElementName] on Subsystem [MemoryElementName]has recovered. (DIMM 7)

Explanation: This message is for the use case when an implementation has detected a Memory Scrub failure recovery.

May also be shown as 816f030c2007xxxx or 0x816f030c2007xxxx

Severity: Info

Alert Category: Critical - Memory

Serviceable: No

CIM Information: Prefix: PLAT and ID: 0137

SNMP Trap ID: 41

Automatically notify Support: No

User response: No action; information only.

816f030c-2008xxxx Scrub Failure for [PhysicalMemoryElementName] on Subsystem [MemoryElementName]has recovered. (DIMM 8)

Explanation: This message is for the use case when an implementation has detected a Memory Scrub failure recovery.

May also be shown as 816f030c2008xxxx or 0x816f030c2008xxxx

Severity: Info

Alert Category: Critical - Memory

Serviceable: No

CIM Information: Prefix: PLAT and ID: 0137

SNMP Trap ID: 41

Automatically notify Support: No

User response: No action; information only.

816f030c-2009xxxx Scrub Failure for [PhysicalMemoryElementName] on Subsystem [MemoryElementName]has recovered. (DIMM 9)

Explanation: This message is for the use case when an implementation has detected a Memory Scrub failure recovery.

May also be shown as 816f030c2009xxxx or 0x816f030c2009xxxx

Severity: Info

Alert Category: Critical - Memory

Serviceable: No

CIM Information: Prefix: PLAT and ID: 0137

SNMP Trap ID: 41

Automatically notify Support: No

User response: No action; information only.

816f030c-200axxxx Scrub Failure for [PhysicalMemoryElementName] on Subsystem [MemoryElementName]has recovered. (DIMM 10)

Explanation: This message is for the use case when an implementation has detected a Memory Scrub failure recovery.

May also be shown as 816f030c200axxxx or 0x816f030c200axxxx

Severity: Info

Alert Category: Critical - Memory

Serviceable: No

CIM Information: Prefix: PLAT and ID: 0137

SNMP Trap ID: 41

Automatically notify Support: No

User response: No action; information only.

816f030c-200bxxxx Scrub Failure for [PhysicalMemoryElementName] on Subsystem [MemoryElementName]has recovered. (DIMM 11)

Explanation: This message is for the use case when an implementation has detected a Memory Scrub failure recovery.

May also be shown as 816f030c200bxxxx or 0x816f030c200bxxxx

Severity: Info

Alert Category: Critical - Memory

Serviceable: No

CIM Information: Prefix: PLAT and ID: 0137

SNMP Trap ID: 41

Automatically notify Support: No

User response: No action; information only.

816f030c-200cxxxx • 816f030c-200exxxx

816f030c-200cxxxx Scrub Failure for [PhysicalMemoryElementName] on Subsystem [MemoryElementName]has recovered. (DIMM 12)

Explanation: This message is for the use case when an implementation has detected a Memory Scrub failure recovery.

May also be shown as 816f030c200cxxxx or 0x816f030c200cxxxx

Severity: Info

Alert Category: Critical - Memory

Serviceable: No

CIM Information: Prefix: PLAT and ID: 0137

SNMP Trap ID: 41

Automatically notify Support: No

User response: No action; information only.

816f030c-200dxxxx Scrub Failure for [PhysicalMemoryElementName] on Subsystem [MemoryElementName]has recovered. (DIMM 13)

Explanation: This message is for the use case when an implementation has detected a Memory Scrub failure recovery.

May also be shown as 816f030c200dxxxx or 0x816f030c200dxxxx

Severity: Info

Alert Category: Critical - Memory

Serviceable: No

CIM Information: Prefix: PLAT and ID: 0137

SNMP Trap ID: 41

Automatically notify Support: No

User response: No action; information only.

816f030c-200exxxx Scrub Failure for [PhysicalMemoryElementName] on Subsystem [MemoryElementName]has recovered. (DIMM 14)

Explanation: This message is for the use case when an implementation has detected a Memory Scrub failure recovery.

May also be shown as 816f030c200exxxx or 0x816f030c200exxxx

Severity: Info

Alert Category: Critical - Memory

Serviceable: No

CIM Information: Prefix: PLAT and ID: 0137

SNMP Trap ID: 41

Automatically notify Support: No

User response: No action; information only.

816f030c-200fxxxx Scrub Failure for [PhysicalMemoryElementName] on Subsystem [MemoryElementName]has recovered. (DIMM 15)

Explanation: This message is for the use case when an implementation has detected a Memory Scrub failure recovery.

May also be shown as 816f030c200fxxxx or 0x816f030c200fxxxx

Severity: Info

Alert Category: Critical - Memory

Serviceable: No

CIM Information: Prefix: PLAT and ID: 0137

SNMP Trap ID: 41

Automatically notify Support: No

User response: No action; information only.

816f030c-2010xxxx Scrub Failure for [PhysicalMemoryElementName] on Subsystem [MemoryElementName]has recovered. (DIMM 16)

Explanation: This message is for the use case when an implementation has detected a Memory Scrub failure recovery.

May also be shown as 816f030c2010xxxx or 0x816f030c2010xxxx

Severity: Info

Alert Category: Critical - Memory

Serviceable: No

CIM Information: Prefix: PLAT and ID: 0137

SNMP Trap ID: 41

Automatically notify Support: No

User response: No action; information only.

816f030c-2011xxxx Scrub Failure for [PhysicalMemoryElementName] on Subsystem [MemoryElementName]has recovered. (DIMM 17)

Explanation: This message is for the use case when an implementation has detected a Memory Scrub failure recovery.

May also be shown as 816f030c2011xxxx or 0x816f030c2011xxxx

Severity: Info

Alert Category: Critical - Memory

Serviceable: No

CIM Information: Prefix: PLAT and ID: 0137

SNMP Trap ID: 41

Automatically notify Support: No

User response: No action; information only.

816f030c-2012xxxx Scrub Failure for [PhysicalMemoryElementName] on Subsystem [MemoryElementName]has recovered. (DIMM 18)

Explanation: This message is for the use case when an implementation has detected a Memory Scrub failure recovery.

May also be shown as 816f030c2012xxxx or 0x816f030c2012xxxx

Severity: Info

Alert Category: Critical - Memory

Serviceable: No

CIM Information: Prefix: PLAT and ID: 0137

SNMP Trap ID: 41

Automatically notify Support: No

User response: No action; information only.

816f030c-2581xxxx Scrub Failure for [PhysicalMemoryElementName] on Subsystem [MemoryElementName]has recovered. (All DIMMS)

Explanation: This message is for the use case when an implementation has detected a Memory Scrub failure recovery.

May also be shown as 816f030c2581xxxx or 0x816f030c2581xxxx

Severity: Info

Alert Category: Critical - Memory

Serviceable: No

CIM Information: Prefix: PLAT and ID: 0137

SNMP Trap ID: 41

Automatically notify Support: No

User response: No action; information only. One of the DIMMs :

816f0313-1701xxxx System [ComputerSystemElementName] has recovered from an NMI. (NMI State)

Explanation: This message is for the use case when an implementation has detected a Software NMI has been Recovered from.

May also be shown as 816f03131701xxxx or 0x816f03131701xxxx

Severity: Info

Alert Category: Critical - Other

Serviceable: No

CIM Information: Prefix: PLAT and ID: 0230

SNMP Trap ID: 50

Automatically notify Support: No

User response: No action; information only.

816f040c-2001xxxx [PhysicalMemoryElementName] Enabled on Subsystem [MemoryElementName]. (DIMM 1)

Explanation: This message is for the use case when an implementation has detected that Memory has been Enabled.
May also be shown as 816f040c2001xxxx or 0x816f040c2001xxxx

Severity: Info

Alert Category: System - Other

Serviceable: No

CIM Information: Prefix: PLAT and ID: 0130

SNMP Trap ID:

Automatically notify Support: No

User response: No action; information only.

816f040c-2002xxxx [PhysicalMemoryElementName] Enabled on Subsystem [MemoryElementName]. (DIMM 2)

Explanation: This message is for the use case when an implementation has detected that Memory has been Enabled.
May also be shown as 816f040c2002xxxx or 0x816f040c2002xxxx

Severity: Info

Alert Category: System - Other

Serviceable: No

CIM Information: Prefix: PLAT and ID: 0130

SNMP Trap ID:

Automatically notify Support: No

User response: No action; information only.

816f040c-2003xxxx [PhysicalMemoryElementName] Enabled on Subsystem [MemoryElementName]. (DIMM 3)

Explanation: This message is for the use case when an implementation has detected that Memory has been Enabled.
May also be shown as 816f040c2003xxxx or 0x816f040c2003xxxx

Severity: Info

Alert Category: System - Other

Serviceable: No

CIM Information: Prefix: PLAT and ID: 0130

SNMP Trap ID:

Automatically notify Support: No

User response: No action; information only.

816f040c-2004xxxx [PhysicalMemoryElementName] Enabled on Subsystem [MemoryElementName]. (DIMM 4)

Explanation: This message is for the use case when an implementation has detected that Memory has been Enabled.

May also be shown as 816f040c2004xxxx or 0x816f040c2004xxxx

Severity: Info

Alert Category: System - Other

Serviceable: No

CIM Information: Prefix: PLAT and ID: 0130

SNMP Trap ID:

Automatically notify Support: No

User response: No action; information only.

816f040c-2005xxxx [PhysicalMemoryElementName] Enabled on Subsystem [MemoryElementName]. (DIMM 5)

Explanation: This message is for the use case when an implementation has detected that Memory has been Enabled.

May also be shown as 816f040c2005xxxx or 0x816f040c2005xxxx

Severity: Info

Alert Category: System - Other

Serviceable: No

CIM Information: Prefix: PLAT and ID: 0130

SNMP Trap ID:

Automatically notify Support: No

User response: No action; information only.

816f040c-2006xxxx [PhysicalMemoryElementName] Enabled on Subsystem [MemoryElementName]. (DIMM 6)

Explanation: This message is for the use case when an implementation has detected that Memory has been Enabled.

May also be shown as 816f040c2006xxxx or 0x816f040c2006xxxx

Severity: Info

Alert Category: System - Other

Serviceable: No

CIM Information: Prefix: PLAT and ID: 0130

SNMP Trap ID:

Automatically notify Support: No

User response: No action; information only.

816f040c-2007xxxx [PhysicalMemoryElementName] Enabled on Subsystem [MemoryElementName]. (DIMM 7)

Explanation: This message is for the use case when an implementation has detected that Memory has been Enabled.
May also be shown as 816f040c2007xxxx or 0x816f040c2007xxxx

Severity: Info

Alert Category: System - Other

Serviceable: No

CIM Information: Prefix: PLAT and ID: 0130

SNMP Trap ID:

Automatically notify Support: No

User response: No action; information only.

816f040c-2008xxxx [PhysicalMemoryElementName] Enabled on Subsystem [MemoryElementName]. (DIMM 8)

Explanation: This message is for the use case when an implementation has detected that Memory has been Enabled.
May also be shown as 816f040c2008xxxx or 0x816f040c2008xxxx

Severity: Info

Alert Category: System - Other

Serviceable: No

CIM Information: Prefix: PLAT and ID: 0130

SNMP Trap ID:

Automatically notify Support: No

User response: No action; information only.

816f040c-2009xxxx [PhysicalMemoryElementName] Enabled on Subsystem [MemoryElementName]. (DIMM 9)

Explanation: This message is for the use case when an implementation has detected that Memory has been Enabled.
May also be shown as 816f040c2009xxxx or 0x816f040c2009xxxx

Severity: Info

Alert Category: System - Other

Serviceable: No

CIM Information: Prefix: PLAT and ID: 0130

SNMP Trap ID:

Automatically notify Support: No

User response: No action; information only.

816f040c-200axxxx • 816f040c-200cxxxx

816f040c-200axxxx [PhysicalMemoryElementName] Enabled on Subsystem [MemoryElementName]. (DIMM 10)

Explanation: This message is for the use case when an implementation has detected that Memory has been Enabled.

May also be shown as 816f040c200axxxx or 0x816f040c200axxxx

Severity: Info

Alert Category: System - Other

Serviceable: No

CIM Information: Prefix: PLAT and ID: 0130

SNMP Trap ID:

Automatically notify Support: No

User response: No action; information only.

816f040c-200bxxxx [PhysicalMemoryElementName] Enabled on Subsystem [MemoryElementName]. (DIMM 11)

Explanation: This message is for the use case when an implementation has detected that Memory has been Enabled.

May also be shown as 816f040c200bxxxx or 0x816f040c200bxxxx

Severity: Info

Alert Category: System - Other

Serviceable: No

CIM Information: Prefix: PLAT and ID: 0130

SNMP Trap ID:

Automatically notify Support: No

User response: No action; information only.

816f040c-200cxxxx [PhysicalMemoryElementName] Enabled on Subsystem [MemoryElementName]. (DIMM 12)

Explanation: This message is for the use case when an implementation has detected that Memory has been Enabled.

May also be shown as 816f040c200cxxxx or 0x816f040c200cxxxx

Severity: Info

Alert Category: System - Other

Serviceable: No

CIM Information: Prefix: PLAT and ID: 0130

SNMP Trap ID:

Automatically notify Support: No

User response: No action; information only.

816f040c-200dxxxx [PhysicalMemoryElementName] Enabled on Subsystem [MemoryElementName]. (DIMM 13)

Explanation: This message is for the use case when an implementation has detected that Memory has been Enabled.
May also be shown as 816f040c200dxxxx or 0x816f040c200dxxxx

Severity: Info

Alert Category: System - Other

Serviceable: No

CIM Information: Prefix: PLAT and ID: 0130

SNMP Trap ID:

Automatically notify Support: No

User response: No action; information only.

816f040c-200exxxx [PhysicalMemoryElementName] Enabled on Subsystem [MemoryElementName]. (DIMM 14)

Explanation: This message is for the use case when an implementation has detected that Memory has been Enabled.
May also be shown as 816f040c200exxxx or 0x816f040c200exxxx

Severity: Info

Alert Category: System - Other

Serviceable: No

CIM Information: Prefix: PLAT and ID: 0130

SNMP Trap ID:

Automatically notify Support: No

User response: No action; information only.

816f040c-200fxxxx [PhysicalMemoryElementName] Enabled on Subsystem [MemoryElementName]. (DIMM 15)

Explanation: This message is for the use case when an implementation has detected that Memory has been Enabled.
May also be shown as 816f040c200fxxxx or 0x816f040c200fxxxx

Severity: Info

Alert Category: System - Other

Serviceable: No

CIM Information: Prefix: PLAT and ID: 0130

SNMP Trap ID:

Automatically notify Support: No

User response: No action; information only.

816f040c-2010xxxx [PhysicalMemoryElementName] Enabled on Subsystem [MemoryElementName]. (DIMM 16)

Explanation: This message is for the use case when an implementation has detected that Memory has been Enabled.

May also be shown as 816f040c2010xxxx or 0x816f040c2010xxxx

Severity: Info

Alert Category: System - Other

Serviceable: No

CIM Information: Prefix: PLAT and ID: 0130

SNMP Trap ID:

Automatically notify Support: No

User response: No action; information only.

816f040c-2011xxxx [PhysicalMemoryElementName] Enabled on Subsystem [MemoryElementName]. (DIMM 17)

Explanation: This message is for the use case when an implementation has detected that Memory has been Enabled.

May also be shown as 816f040c2011xxxx or 0x816f040c2011xxxx

Severity: Info

Alert Category: System - Other

Serviceable: No

CIM Information: Prefix: PLAT and ID: 0130

SNMP Trap ID:

Automatically notify Support: No

User response: No action; information only.

816f040c-2012xxxx [PhysicalMemoryElementName] Enabled on Subsystem [MemoryElementName]. (DIMM 18)

Explanation: This message is for the use case when an implementation has detected that Memory has been Enabled.

May also be shown as 816f040c2012xxxx or 0x816f040c2012xxxx

Severity: Info

Alert Category: System - Other

Serviceable: No

CIM Information: Prefix: PLAT and ID: 0130

SNMP Trap ID:

Automatically notify Support: No

User response: No action; information only.

816f040c-2581xxxx [PhysicalMemoryElementName] Enabled on Subsystem [MemoryElementName]. (All DIMMS)

Explanation: This message is for the use case when an implementation has detected that Memory has been Enabled. May also be shown as 816f040c2581xxxx or 0x816f040c2581xxxx

Severity: Info

Alert Category: System - Other

Serviceable: No

CIM Information: Prefix: PLAT and ID: 0130

SNMP Trap ID:

Automatically notify Support: No

User response: No action; information only. One of the DIMMs :

816f0413-2582xxxx A PCI PERR recovery has occurred on system [ComputerSystemElementName]. (PCIs)

Explanation: This message is for the use case when an implementation has detected a PCI PERR recovered. May also be shown as 816f04132582xxxx or 0x816f04132582xxxx

Severity: Info

Alert Category: Critical - Other

Serviceable: No

CIM Information: Prefix: PLAT and ID: 0233

SNMP Trap ID: 50

Automatically notify Support: No

User response: No action; information only.

816f0507-0301xxxx [ProcessorElementName] has Recovered from a Configuration Mismatch. (CPU 1)

Explanation: This message is for the use case when an implementation has Recovered from a Processor Configuration Mismatch.

May also be shown as 816f05070301xxxx or 0x816f05070301xxxx

Severity: Info

Alert Category: Critical - CPU

Serviceable: No

CIM Information: Prefix: PLAT and ID: 0063

SNMP Trap ID: 40

Automatically notify Support: No

User response: No action; information only.

816f0507-0302xxxx [ProcessorElementName] has Recovered from a Configuration Mismatch. (CPU 2)

Explanation: This message is for the use case when an implementation has Recovered from a Processor Configuration Mismatch.

May also be shown as 816f05070302xxxx or 0x816f05070302xxxx

Severity: Info

Alert Category: Critical - CPU

Serviceable: No

CIM Information: Prefix: PLAT and ID: 0063

SNMP Trap ID: 40

Automatically notify Support: No

User response: No action; information only.

816f050c-2001xxxx Memory Logging Limit Removed for [PhysicalMemoryElementName] on Subsystem [MemoryElementName]. (DIMM 1)

Explanation: This message is for the use case when an implementation has detected that the Memory Logging Limit has been Removed.

May also be shown as 816f050c2001xxxx or 0x816f050c2001xxxx

Severity: Info

Alert Category: Warning - Memory

Serviceable: No

CIM Information: Prefix: PLAT and ID: 0145

SNMP Trap ID: 43

Automatically notify Support: No

User response: No action; information only.

816f050c-2002xxxx Memory Logging Limit Removed for [PhysicalMemoryElementName] on Subsystem [MemoryElementName]. (DIMM 2)

Explanation: This message is for the use case when an implementation has detected that the Memory Logging Limit has been Removed.

May also be shown as 816f050c2002xxxx or 0x816f050c2002xxxx

Severity: Info

Alert Category: Warning - Memory

Serviceable: No

CIM Information: Prefix: PLAT and ID: 0145

SNMP Trap ID: 43

Automatically notify Support: No

User response: No action; information only.

816f050c-2003xxxx Memory Logging Limit Removed for [PhysicalMemoryElementName] on Subsystem [MemoryElementName]. (DIMM 3)

Explanation: This message is for the use case when an implementation has detected that the Memory Logging Limit has been Removed.

May also be shown as 816f050c2003xxxx or 0x816f050c2003xxxx

Severity: Info

Alert Category: Warning - Memory

Serviceable: No

CIM Information: Prefix: PLAT and ID: 0145

SNMP Trap ID: 43

Automatically notify Support: No

User response: No action; information only.

816f050c-2004xxxx Memory Logging Limit Removed for [PhysicalMemoryElementName] on Subsystem [MemoryElementName]. (DIMM 4)

Explanation: This message is for the use case when an implementation has detected that the Memory Logging Limit has been Removed.

May also be shown as 816f050c2004xxxx or 0x816f050c2004xxxx

Severity: Info

Alert Category: Warning - Memory

Serviceable: No

CIM Information: Prefix: PLAT and ID: 0145

SNMP Trap ID: 43

Automatically notify Support: No

User response: No action; information only.

816f050c-2005xxxx Memory Logging Limit Removed for [PhysicalMemoryElementName] on Subsystem [MemoryElementName]. (DIMM 5)

Explanation: This message is for the use case when an implementation has detected that the Memory Logging Limit has been Removed.

May also be shown as 816f050c2005xxxx or 0x816f050c2005xxxx

Severity: Info

Alert Category: Warning - Memory

Serviceable: No

CIM Information: Prefix: PLAT and ID: 0145

SNMP Trap ID: 43

Automatically notify Support: No

User response: No action; information only.

816f050c-2006xxxx Memory Logging Limit Removed for [PhysicalMemoryElementName] on Subsystem [MemoryElementName]. (DIMM 6)

Explanation: This message is for the use case when an implementation has detected that the Memory Logging Limit has been Removed.

May also be shown as 816f050c2006xxxx or 0x816f050c2006xxxx

Severity: Info

Alert Category: Warning - Memory

Serviceable: No

CIM Information: Prefix: PLAT and ID: 0145

SNMP Trap ID: 43

Automatically notify Support: No

User response: No action; information only.

816f050c-2007xxxx Memory Logging Limit Removed for [PhysicalMemoryElementName] on Subsystem [MemoryElementName]. (DIMM 7)

Explanation: This message is for the use case when an implementation has detected that the Memory Logging Limit has been Removed.

May also be shown as 816f050c2007xxxx or 0x816f050c2007xxxx

Severity: Info

Alert Category: Warning - Memory

Serviceable: No

CIM Information: Prefix: PLAT and ID: 0145

SNMP Trap ID: 43

Automatically notify Support: No

User response: No action; information only.

816f050c-2008xxxx Memory Logging Limit Removed for [PhysicalMemoryElementName] on Subsystem [MemoryElementName]. (DIMM 8)

Explanation: This message is for the use case when an implementation has detected that the Memory Logging Limit has been Removed.

May also be shown as 816f050c2008xxxx or 0x816f050c2008xxxx

Severity: Info

Alert Category: Warning - Memory

Serviceable: No

CIM Information: Prefix: PLAT and ID: 0145

SNMP Trap ID: 43

Automatically notify Support: No

User response: No action; information only.

816f050c-2009xxxx Memory Logging Limit Removed for [PhysicalMemoryElementName] on Subsystem [MemoryElementName]. (DIMM 9)

Explanation: This message is for the use case when an implementation has detected that the Memory Logging Limit has been Removed.

May also be shown as 816f050c2009xxxx or 0x816f050c2009xxxx

Severity: Info

Alert Category: Warning - Memory

Serviceable: No

CIM Information: Prefix: PLAT and ID: 0145

SNMP Trap ID: 43

Automatically notify Support: No

User response: No action; information only.

816f050c-200axxxx Memory Logging Limit Removed for [PhysicalMemoryElementName] on Subsystem [MemoryElementName]. (DIMM 10)

Explanation: This message is for the use case when an implementation has detected that the Memory Logging Limit has been Removed.

May also be shown as 816f050c200axxxx or 0x816f050c200axxxx

Severity: Info

Alert Category: Warning - Memory

Serviceable: No

CIM Information: Prefix: PLAT and ID: 0145

SNMP Trap ID: 43

Automatically notify Support: No

User response: No action; information only.

816f050c-200bxxxx Memory Logging Limit Removed for [PhysicalMemoryElementName] on Subsystem [MemoryElementName]. (DIMM 11)

Explanation: This message is for the use case when an implementation has detected that the Memory Logging Limit has been Removed.

May also be shown as 816f050c200bxxxx or 0x816f050c200bxxxx

Severity: Info

Alert Category: Warning - Memory

Serviceable: No

CIM Information: Prefix: PLAT and ID: 0145

SNMP Trap ID: 43

Automatically notify Support: No

User response: No action; information only.

816f050c-200cxxxx • 816f050c-200exxxx

816f050c-200cxxxx Memory Logging Limit Removed for [PhysicalMemoryElementName] on Subsystem [MemoryElementName]. (DIMM 12)

Explanation: This message is for the use case when an implementation has detected that the Memory Logging Limit has been Removed.

May also be shown as 816f050c200cxxxx or 0x816f050c200cxxxx

Severity: Info

Alert Category: Warning - Memory

Serviceable: No

CIM Information: Prefix: PLAT and ID: 0145

SNMP Trap ID: 43

Automatically notify Support: No

User response: No action; information only.

816f050c-200dxxxx Memory Logging Limit Removed for [PhysicalMemoryElementName] on Subsystem [MemoryElementName]. (DIMM 13)

Explanation: This message is for the use case when an implementation has detected that the Memory Logging Limit has been Removed.

May also be shown as 816f050c200dxxxx or 0x816f050c200dxxxx

Severity: Info

Alert Category: Warning - Memory

Serviceable: No

CIM Information: Prefix: PLAT and ID: 0145

SNMP Trap ID: 43

Automatically notify Support: No

User response: No action; information only.

816f050c-200exxxx Memory Logging Limit Removed for [PhysicalMemoryElementName] on Subsystem [MemoryElementName]. (DIMM 14)

Explanation: This message is for the use case when an implementation has detected that the Memory Logging Limit has been Removed.

May also be shown as 816f050c200exxxx or 0x816f050c200exxxx

Severity: Info

Alert Category: Warning - Memory

Serviceable: No

CIM Information: Prefix: PLAT and ID: 0145

SNMP Trap ID: 43

Automatically notify Support: No

User response: No action; information only.

816f050c-200fxxxx Memory Logging Limit Removed for [PhysicalMemoryElementName] on Subsystem [MemoryElementName]. (DIMM 15)

Explanation: This message is for the use case when an implementation has detected that the Memory Logging Limit has been Removed.

May also be shown as 816f050c200fxxxx or 0x816f050c200fxxxx

Severity: Info

Alert Category: Warning - Memory

Serviceable: No

CIM Information: Prefix: PLAT and ID: 0145

SNMP Trap ID: 43

Automatically notify Support: No

User response: No action; information only.

816f050c-2010xxxx Memory Logging Limit Removed for [PhysicalMemoryElementName] on Subsystem [MemoryElementName]. (DIMM 16)

Explanation: This message is for the use case when an implementation has detected that the Memory Logging Limit has been Removed.

May also be shown as 816f050c2010xxxx or 0x816f050c2010xxxx

Severity: Info

Alert Category: Warning - Memory

Serviceable: No

CIM Information: Prefix: PLAT and ID: 0145

SNMP Trap ID: 43

Automatically notify Support: No

User response: No action; information only.

816f050c-2011xxxx Memory Logging Limit Removed for [PhysicalMemoryElementName] on Subsystem [MemoryElementName]. (DIMM 17)

Explanation: This message is for the use case when an implementation has detected that the Memory Logging Limit has been Removed.

May also be shown as 816f050c2011xxxx or 0x816f050c2011xxxx

Severity: Info

Alert Category: Warning - Memory

Serviceable: No

CIM Information: Prefix: PLAT and ID: 0145

SNMP Trap ID: 43

Automatically notify Support: No

User response: No action; information only.

816f050c-2012xxxx Memory Logging Limit Removed for [PhysicalMemoryElementName] on Subsystem [MemoryElementName]. (DIMM 18)

Explanation: This message is for the use case when an implementation has detected that the Memory Logging Limit has been Removed.

May also be shown as 816f050c2012xxxx or 0x816f050c2012xxxx

Severity: Info

Alert Category: Warning - Memory

Serviceable: No

CIM Information: Prefix: PLAT and ID: 0145

SNMP Trap ID: 43

Automatically notify Support: No

User response: No action; information only.

816f050c-2581xxxx Memory Logging Limit Removed for [PhysicalMemoryElementName] on Subsystem [MemoryElementName]. (All DIMMS)

Explanation: This message is for the use case when an implementation has detected that the Memory Logging Limit has been Removed.

May also be shown as 816f050c2581xxxx or 0x816f050c2581xxxx

Severity: Info

Alert Category: Warning - Memory

Serviceable: No

CIM Information: Prefix: PLAT and ID: 0145

SNMP Trap ID: 43

Automatically notify Support: No

User response: No action; information only. One of the DIMMs :

816f050d-0400xxxx Critical Array [ComputerSystemElementName] has deasserted. (Drive 0)

Explanation: This message is for the use case when an implementation has detected that an Critical Array has deasserted.

May also be shown as 816f050d0400xxxx or 0x816f050d0400xxxx

Severity: Info

Alert Category: Critical - Hard Disk drive

Serviceable: No

CIM Information: Prefix: PLAT and ID: 0175

SNMP Trap ID: 5

Automatically notify Support: No

User response: No action; information only.

816f050d-0401xxxx Critical Array [ComputerSystemElementName] has deasserted. (Drive 1)

Explanation: This message is for the use case when an implementation has detected that an Critical Array has deasserted.

May also be shown as 816f050d0401xxxx or 0x816f050d0401xxxx

Severity: Info

Alert Category: Critical - Hard Disk drive

Serviceable: No

CIM Information: Prefix: PLAT and ID: 0175

SNMP Trap ID: 5

Automatically notify Support: No

User response: No action; information only.

816f050d-0402xxxx Critical Array [ComputerSystemElementName] has deasserted. (Drive 2)

Explanation: This message is for the use case when an implementation has detected that an Critical Array has deasserted.

May also be shown as 816f050d0402xxxx or 0x816f050d0402xxxx

Severity: Info

Alert Category: Critical - Hard Disk drive

Serviceable: No

CIM Information: Prefix: PLAT and ID: 0175

SNMP Trap ID: 5

Automatically notify Support: No

User response: No action; information only.

816f050d-0403xxxx Critical Array [ComputerSystemElementName] has deasserted. (Drive 3)

Explanation: This message is for the use case when an implementation has detected that an Critical Array has deasserted.

May also be shown as 816f050d0403xxxx or 0x816f050d0403xxxx

Severity: Info

Alert Category: Critical - Hard Disk drive

Serviceable: No

CIM Information: Prefix: PLAT and ID: 0175

SNMP Trap ID: 5

Automatically notify Support: No

User response: No action; information only.

816f050d-0404xxxx • 816f050d-0406xxxx

816f050d-0404xxxx Critical Array [ComputerSystemElementName] has deasserted. (Drive 4)

Explanation: This message is for the use case when an implementation has detected that an Critical Array has deasserted.

May also be shown as 816f050d0404xxxx or 0x816f050d0404xxxx

Severity: Info

Alert Category: Critical - Hard Disk drive

Serviceable: No

CIM Information: Prefix: PLAT and ID: 0175

SNMP Trap ID: 5

Automatically notify Support: No

User response: No action; information only.

816f050d-0405xxxx Critical Array [ComputerSystemElementName] has deasserted. (Drive 5)

Explanation: This message is for the use case when an implementation has detected that an Critical Array has deasserted.

May also be shown as 816f050d0405xxxx or 0x816f050d0405xxxx

Severity: Info

Alert Category: Critical - Hard Disk drive

Serviceable: No

CIM Information: Prefix: PLAT and ID: 0175

SNMP Trap ID: 5

Automatically notify Support: No

User response: No action; information only.

816f050d-0406xxxx Critical Array [ComputerSystemElementName] has deasserted. (Drive 6)

Explanation: This message is for the use case when an implementation has detected that an Critical Array has deasserted.

May also be shown as 816f050d0406xxxx or 0x816f050d0406xxxx

Severity: Info

Alert Category: Critical - Hard Disk drive

Serviceable: No

CIM Information: Prefix: PLAT and ID: 0175

SNMP Trap ID: 5

Automatically notify Support: No

User response: No action; information only.

816f050d-0407xxxx Critical Array [ComputerSystemElementName] has deasserted. (Drive 7)

Explanation: This message is for the use case when an implementation has detected that an Critical Array has deasserted.

May also be shown as 816f050d0407xxxx or 0x816f050d0407xxxx

Severity: Info

Alert Category: Critical - Hard Disk drive

Serviceable: No

CIM Information: Prefix: PLAT and ID: 0175

SNMP Trap ID: 5

Automatically notify Support: No

User response: No action; information only.

816f0607-0301xxxx An SM BIOS Uncorrectable CPU complex error for [ProcessorElementName] has deasserted. (CPU 1)

Explanation: This message is for the use case when an SM BIOS Uncorrectable CPU complex error has deasserted.

May also be shown as 816f06070301xxxx or 0x816f06070301xxxx

Severity: Info

Alert Category: Critical - CPU

Serviceable: No

CIM Information: Prefix: PLAT and ID: 0817

SNMP Trap ID: 40

Automatically notify Support: No

User response: No action; information only.

816f0607-0302xxxx An SM BIOS Uncorrectable CPU complex error for [ProcessorElementName] has deasserted. (CPU 2)

Explanation: This message is for the use case when an SM BIOS Uncorrectable CPU complex error has deasserted.

May also be shown as 816f06070302xxxx or 0x816f06070302xxxx

Severity: Info

Alert Category: Critical - CPU

Serviceable: No

CIM Information: Prefix: PLAT and ID: 0817

SNMP Trap ID: 40

Automatically notify Support: No

User response: No action; information only.

816f060d-0400xxxx • 816f060d-0402xxxx

816f060d-0400xxxx Array in system [ComputerSystemElementName] has been restored. (Drive 0)

Explanation: This message is for the use case when an implementation has detected that a Failed Array has been Restored.

May also be shown as 816f060d0400xxxx or 0x816f060d0400xxxx

Severity: Info

Alert Category: Critical - Hard Disk drive

Serviceable: No

CIM Information: Prefix: PLAT and ID: 0177

SNMP Trap ID: 5

Automatically notify Support: No

User response: No action; information only.

816f060d-0401xxxx Array in system [ComputerSystemElementName] has been restored. (Drive 1)

Explanation: This message is for the use case when an implementation has detected that a Failed Array has been Restored.

May also be shown as 816f060d0401xxxx or 0x816f060d0401xxxx

Severity: Info

Alert Category: Critical - Hard Disk drive

Serviceable: No

CIM Information: Prefix: PLAT and ID: 0177

SNMP Trap ID: 5

Automatically notify Support: No

User response: No action; information only.

816f060d-0402xxxx Array in system [ComputerSystemElementName] has been restored. (Drive 2)

Explanation: This message is for the use case when an implementation has detected that a Failed Array has been Restored.

May also be shown as 816f060d0402xxxx or 0x816f060d0402xxxx

Severity: Info

Alert Category: Critical - Hard Disk drive

Serviceable: No

CIM Information: Prefix: PLAT and ID: 0177

SNMP Trap ID: 5

Automatically notify Support: No

User response: No action; information only.

816f060d-0403xxxx Array in system [ComputerSystemElementName] has been restored. (Drive 3)

Explanation: This message is for the use case when an implementation has detected that a Failed Array has been Restored.

May also be shown as 816f060d0403xxxx or 0x816f060d0403xxxx

Severity: Info

Alert Category: Critical - Hard Disk drive

Serviceable: No

CIM Information: Prefix: PLAT and ID: 0177

SNMP Trap ID: 5

Automatically notify Support: No

User response: No action; information only.

816f060d-0404xxxx Array in system [ComputerSystemElementName] has been restored. (Drive 4)

Explanation: This message is for the use case when an implementation has detected that a Failed Array has been Restored.

May also be shown as 816f060d0404xxxx or 0x816f060d0404xxxx

Severity: Info

Alert Category: Critical - Hard Disk drive

Serviceable: No

CIM Information: Prefix: PLAT and ID: 0177

SNMP Trap ID: 5

Automatically notify Support: No

User response: No action; information only.

816f060d-0405xxxx Array in system [ComputerSystemElementName] has been restored. (Drive 5)

Explanation: This message is for the use case when an implementation has detected that a Failed Array has been Restored.

May also be shown as 816f060d0405xxxx or 0x816f060d0405xxxx

Severity: Info

Alert Category: Critical - Hard Disk drive

Serviceable: No

CIM Information: Prefix: PLAT and ID: 0177

SNMP Trap ID: 5

Automatically notify Support: No

User response: No action; information only.

816f060d-0406xxxx • 816f070c-2001xxxx

816f060d-0406xxxx Array in system [ComputerSystemElementName] has been restored. (Drive 6)

Explanation: This message is for the use case when an implementation has detected that a Failed Array has been Restored.

May also be shown as 816f060d0406xxxx or 0x816f060d0406xxxx

Severity: Info

Alert Category: Critical - Hard Disk drive

Serviceable: No

CIM Information: Prefix: PLAT and ID: 0177

SNMP Trap ID: 5

Automatically notify Support: No

User response: No action; information only.

816f060d-0407xxxx Array in system [ComputerSystemElementName] has been restored. (Drive 7)

Explanation: This message is for the use case when an implementation has detected that a Failed Array has been Restored.

May also be shown as 816f060d0407xxxx or 0x816f060d0407xxxx

Severity: Info

Alert Category: Critical - Hard Disk drive

Serviceable: No

CIM Information: Prefix: PLAT and ID: 0177

SNMP Trap ID: 5

Automatically notify Support: No

User response: No action; information only.

816f070c-2001xxxx Configuration error for [PhysicalMemoryElementName] on Subsystem
[MemoryElementName]has deasserted. (DIMM 1)

Explanation: This message is for the use case when an implementation has detected a Memory DIMM configuration error has deasserted.

May also be shown as 816f070c2001xxxx or 0x816f070c2001xxxx

Severity: Info

Alert Category: Critical - Memory

Serviceable: No

CIM Information: Prefix: PLAT and ID: 0127

SNMP Trap ID: 41

Automatically notify Support: No

User response: No action; information only.

**816f070c-2002xxxx Configuration error for [PhysicalMemoryElementName] on Subsystem
[MemoryElementName]has deasserted. (DIMM 2)**

Explanation: This message is for the use case when an implementation has detected a Memory DIMM configuration error has deasserted.

May also be shown as 816f070c2002xxxx or 0x816f070c2002xxxx

Severity: Info

Alert Category: Critical - Memory

Serviceable: No

CIM Information: Prefix: PLAT and ID: 0127

SNMP Trap ID: 41

Automatically notify Support: No

User response: No action; information only.

**816f070c-2003xxxx Configuration error for [PhysicalMemoryElementName] on Subsystem
[MemoryElementName]has deasserted. (DIMM 3)**

Explanation: This message is for the use case when an implementation has detected a Memory DIMM configuration error has deasserted.

May also be shown as 816f070c2003xxxx or 0x816f070c2003xxxx

Severity: Info

Alert Category: Critical - Memory

Serviceable: No

CIM Information: Prefix: PLAT and ID: 0127

SNMP Trap ID: 41

Automatically notify Support: No

User response: No action; information only.

**816f070c-2004xxxx Configuration error for [PhysicalMemoryElementName] on Subsystem
[MemoryElementName]has deasserted. (DIMM 4)**

Explanation: This message is for the use case when an implementation has detected a Memory DIMM configuration error has deasserted.

May also be shown as 816f070c2004xxxx or 0x816f070c2004xxxx

Severity: Info

Alert Category: Critical - Memory

Serviceable: No

CIM Information: Prefix: PLAT and ID: 0127

SNMP Trap ID: 41

Automatically notify Support: No

User response: No action; information only.

**816f070c-2005xxxx Configuration error for [PhysicalMemoryElementName] on Subsystem
[MemoryElementName]has deasserted. (DIMM 5)**

Explanation: This message is for the use case when an implementation has detected a Memory DIMM configuration error has deasserted.

May also be shown as 816f070c2005xxxx or 0x816f070c2005xxxx

Severity: Info

Alert Category: Critical - Memory

Serviceable: No

CIM Information: Prefix: PLAT and ID: 0127

SNMP Trap ID: 41

Automatically notify Support: No

User response: No action; information only.

**816f070c-2006xxxx Configuration error for [PhysicalMemoryElementName] on Subsystem
[MemoryElementName]has deasserted. (DIMM 6)**

Explanation: This message is for the use case when an implementation has detected a Memory DIMM configuration error has deasserted.

May also be shown as 816f070c2006xxxx or 0x816f070c2006xxxx

Severity: Info

Alert Category: Critical - Memory

Serviceable: No

CIM Information: Prefix: PLAT and ID: 0127

SNMP Trap ID: 41

Automatically notify Support: No

User response: No action; information only.

**816f070c-2007xxxx Configuration error for [PhysicalMemoryElementName] on Subsystem
[MemoryElementName]has deasserted. (DIMM 7)**

Explanation: This message is for the use case when an implementation has detected a Memory DIMM configuration error has deasserted.

May also be shown as 816f070c2007xxxx or 0x816f070c2007xxxx

Severity: Info

Alert Category: Critical - Memory

Serviceable: No

CIM Information: Prefix: PLAT and ID: 0127

SNMP Trap ID: 41

Automatically notify Support: No

User response: No action; information only.

**816f070c-2008xxxx Configuration error for [PhysicalMemoryElementName] on Subsystem
[MemoryElementName]has deasserted. (DIMM 8)**

Explanation: This message is for the use case when an implementation has detected a Memory DIMM configuration error has deasserted.

May also be shown as 816f070c2008xxxx or 0x816f070c2008xxxx

Severity: Info

Alert Category: Critical - Memory

Serviceable: No

CIM Information: Prefix: PLAT and ID: 0127

SNMP Trap ID: 41

Automatically notify Support: No

User response: No action; information only.

**816f070c-2009xxxx Configuration error for [PhysicalMemoryElementName] on Subsystem
[MemoryElementName]has deasserted. (DIMM 9)**

Explanation: This message is for the use case when an implementation has detected a Memory DIMM configuration error has deasserted.

May also be shown as 816f070c2009xxxx or 0x816f070c2009xxxx

Severity: Info

Alert Category: Critical - Memory

Serviceable: No

CIM Information: Prefix: PLAT and ID: 0127

SNMP Trap ID: 41

Automatically notify Support: No

User response: No action; information only.

**816f070c-200axxxx Configuration error for [PhysicalMemoryElementName] on Subsystem
[MemoryElementName]has deasserted. (DIMM 10)**

Explanation: This message is for the use case when an implementation has detected a Memory DIMM configuration error has deasserted.

May also be shown as 816f070c200axxxx or 0x816f070c200axxxx

Severity: Info

Alert Category: Critical - Memory

Serviceable: No

CIM Information: Prefix: PLAT and ID: 0127

SNMP Trap ID: 41

Automatically notify Support: No

User response: No action; information only.

816f070c-200bxxxx • 816f070c-200dxxxx

816f070c-200bxxxx Configuration error for [PhysicalMemoryElementName] on Subsystem [MemoryElementName]has deasserted. (DIMM 11)

Explanation: This message is for the use case when an implementation has detected a Memory DIMM configuration error has deasserted.

May also be shown as 816f070c200bxxxx or 0x816f070c200bxxxx

Severity: Info

Alert Category: Critical - Memory

Serviceable: No

CIM Information: Prefix: PLAT and **ID:** 0127

SNMP Trap ID: 41

Automatically notify Support: No

User response: No action; information only.

816f070c-200cxxxx Configuration error for [PhysicalMemoryElementName] on Subsystem [MemoryElementName]has deasserted. (DIMM 12)

Explanation: This message is for the use case when an implementation has detected a Memory DIMM configuration error has deasserted.

May also be shown as 816f070c200cxxxx or 0x816f070c200cxxxx

Severity: Info

Alert Category: Critical - Memory

Serviceable: No

CIM Information: Prefix: PLAT and **ID:** 0127

SNMP Trap ID: 41

Automatically notify Support: No

User response: No action; information only.

816f070c-200dxxxx Configuration error for [PhysicalMemoryElementName] on Subsystem [MemoryElementName]has deasserted. (DIMM 13)

Explanation: This message is for the use case when an implementation has detected a Memory DIMM configuration error has deasserted.

May also be shown as 816f070c200dxxxx or 0x816f070c200dxxxx

Severity: Info

Alert Category: Critical - Memory

Serviceable: No

CIM Information: Prefix: PLAT and **ID:** 0127

SNMP Trap ID: 41

Automatically notify Support: No

User response: No action; information only.

**816f070c-200exxxx Configuration error for [PhysicalMemoryElementName] on Subsystem
[MemoryElementName]has deasserted. (DIMM 14)**

Explanation: This message is for the use case when an implementation has detected a Memory DIMM configuration error has deasserted.

May also be shown as 816f070c200exxxx or 0x816f070c200exxxx

Severity: Info

Alert Category: Critical - Memory

Serviceable: No

CIM Information: Prefix: PLAT and ID: 0127

SNMP Trap ID: 41

Automatically notify Support: No

User response: No action; information only.

**816f070c-200fxxxx Configuration error for [PhysicalMemoryElementName] on Subsystem
[MemoryElementName]has deasserted. (DIMM 15)**

Explanation: This message is for the use case when an implementation has detected a Memory DIMM configuration error has deasserted.

May also be shown as 816f070c200fxxxx or 0x816f070c200fxxxx

Severity: Info

Alert Category: Critical - Memory

Serviceable: No

CIM Information: Prefix: PLAT and ID: 0127

SNMP Trap ID: 41

Automatically notify Support: No

User response: No action; information only.

**816f070c-2010xxxx Configuration error for [PhysicalMemoryElementName] on Subsystem
[MemoryElementName]has deasserted. (DIMM 16)**

Explanation: This message is for the use case when an implementation has detected a Memory DIMM configuration error has deasserted.

May also be shown as 816f070c2010xxxx or 0x816f070c2010xxxx

Severity: Info

Alert Category: Critical - Memory

Serviceable: No

CIM Information: Prefix: PLAT and ID: 0127

SNMP Trap ID: 41

Automatically notify Support: No

User response: No action; information only.

**816f070c-2011xxxx Configuration error for [PhysicalMemoryElementName] on Subsystem
[MemoryElementName]has deasserted. (DIMM 17)**

Explanation: This message is for the use case when an implementation has detected a Memory DIMM configuration error has deasserted.

May also be shown as 816f070c2011xxxx or 0x816f070c2011xxxx

Severity: Info

Alert Category: Critical - Memory

Serviceable: No

CIM Information: Prefix: PLAT and ID: 0127

SNMP Trap ID: 41

Automatically notify Support: No

User response: No action; information only.

**816f070c-2012xxxx Configuration error for [PhysicalMemoryElementName] on Subsystem
[MemoryElementName]has deasserted. (DIMM 18)**

Explanation: This message is for the use case when an implementation has detected a Memory DIMM configuration error has deasserted.

May also be shown as 816f070c2012xxxx or 0x816f070c2012xxxx

Severity: Info

Alert Category: Critical - Memory

Serviceable: No

CIM Information: Prefix: PLAT and ID: 0127

SNMP Trap ID: 41

Automatically notify Support: No

User response: No action; information only.

**816f070c-2581xxxx Configuration error for [PhysicalMemoryElementName] on Subsystem
[MemoryElementName]has deasserted. (All DIMMS)**

Explanation: This message is for the use case when an implementation has detected a Memory DIMM configuration error has deasserted.

May also be shown as 816f070c2581xxxx or 0x816f070c2581xxxx

Severity: Info

Alert Category: Critical - Memory

Serviceable: No

CIM Information: Prefix: PLAT and ID: 0127

SNMP Trap ID: 41

Automatically notify Support: No

User response: No action; information only. One of the DIMMs :

816f070d-0400xxxx Rebuild completed for Array in system [ComputerSystemElementName]. (Drive 0)

Explanation: This message is for the use case when an implementation has detected that an Array Rebuild has Completed.

May also be shown as 816f070d0400xxxx or 0x816f070d0400xxxx

Severity: Info

Alert Category: System - Other

Serviceable: No

CIM Information: Prefix: PLAT and ID: 0179

SNMP Trap ID:

Automatically notify Support: No

User response: No action; information only.

816f070d-0401xxxx Rebuild completed for Array in system [ComputerSystemElementName]. (Drive 1)

Explanation: This message is for the use case when an implementation has detected that an Array Rebuild has Completed.

May also be shown as 816f070d0401xxxx or 0x816f070d0401xxxx

Severity: Info

Alert Category: System - Other

Serviceable: No

CIM Information: Prefix: PLAT and ID: 0179

SNMP Trap ID:

Automatically notify Support: No

User response: No action; information only.

816f070d-0402xxxx Rebuild completed for Array in system [ComputerSystemElementName]. (Drive 2)

Explanation: This message is for the use case when an implementation has detected that an Array Rebuild has Completed.

May also be shown as 816f070d0402xxxx or 0x816f070d0402xxxx

Severity: Info

Alert Category: System - Other

Serviceable: No

CIM Information: Prefix: PLAT and ID: 0179

SNMP Trap ID:

Automatically notify Support: No

User response: No action; information only.

816f070d-0403xxxx • 816f070d-0405xxxx

816f070d-0403xxxx Rebuild completed for Array in system [ComputerSystemElementName]. (Drive 3)

Explanation: This message is for the use case when an implementation has detected that an Array Rebuild has Completed.

May also be shown as 816f070d0403xxxx or 0x816f070d0403xxxx

Severity: Info

Alert Category: System - Other

Serviceable: No

CIM Information: Prefix: PLAT and ID: 0179

SNMP Trap ID:

Automatically notify Support: No

User response: No action; information only.

816f070d-0404xxxx Rebuild completed for Array in system [ComputerSystemElementName]. (Drive 4)

Explanation: This message is for the use case when an implementation has detected that an Array Rebuild has Completed.

May also be shown as 816f070d0404xxxx or 0x816f070d0404xxxx

Severity: Info

Alert Category: System - Other

Serviceable: No

CIM Information: Prefix: PLAT and ID: 0179

SNMP Trap ID:

Automatically notify Support: No

User response: No action; information only.

816f070d-0405xxxx Rebuild completed for Array in system [ComputerSystemElementName]. (Drive 5)

Explanation: This message is for the use case when an implementation has detected that an Array Rebuild has Completed.

May also be shown as 816f070d0405xxxx or 0x816f070d0405xxxx

Severity: Info

Alert Category: System - Other

Serviceable: No

CIM Information: Prefix: PLAT and ID: 0179

SNMP Trap ID:

Automatically notify Support: No

User response: No action; information only.

816f070d-0406xxxx Rebuild completed for Array in system [ComputerSystemElementName]. (Drive 6)

Explanation: This message is for the use case when an implementation has detected that an Array Rebuild has Completed.

May also be shown as 816f070d0406xxxx or 0x816f070d0406xxxx

Severity: Info

Alert Category: System - Other

Serviceable: No

CIM Information: Prefix: PLAT and ID: 0179

SNMP Trap ID:

Automatically notify Support: No

User response: No action; information only.

816f070d-0407xxxx Rebuild completed for Array in system [ComputerSystemElementName]. (Drive 7)

Explanation: This message is for the use case when an implementation has detected that an Array Rebuild has Completed.

May also be shown as 816f070d0407xxxx or 0x816f070d0407xxxx

Severity: Info

Alert Category: System - Other

Serviceable: No

CIM Information: Prefix: PLAT and ID: 0179

SNMP Trap ID:

Automatically notify Support: No

User response: No action; information only.

816f0807-0301xxxx [ProcessorElementName] has been Enabled. (CPU 1)

Explanation: This message is for the use case when an implementation has detected a Processor has been Enabled.

May also be shown as 816f08070301xxxx or 0x816f08070301xxxx

Severity: Info

Alert Category: System - Other

Serviceable: No

CIM Information: Prefix: PLAT and ID: 0060

SNMP Trap ID:

Automatically notify Support: No

User response: No action; information only.

816f0807-0302xxxx [ProcessorElementName] has been Enabled. (CPU 2)

Explanation: This message is for the use case when an implementation has detected a Processor has been Enabled.

May also be shown as 816f08070302xxxx or 0x816f08070302xxxx

Severity: Info

Alert Category: System - Other

Serviceable: No

CIM Information: Prefix: PLAT and ID: 0060

SNMP Trap ID:

Automatically notify Support: No

User response: No action; information only.

816f0807-2584xxxx [ProcessorElementName] has been Enabled. (All CPUs)

Explanation: This message is for the use case when an implementation has detected a Processor has been Enabled.

May also be shown as 816f08072584xxxx or 0x816f08072584xxxx

Severity: Info

Alert Category: System - Other

Serviceable: No

CIM Information: Prefix: PLAT and ID: 0060

SNMP Trap ID:

Automatically notify Support: No

User response: No action; information only. One of the CPUs :

816f0813-2581xxxx System [ComputerSystemElementName]has recovered from an Uncorrectable Bus Error.
(DIMMs)

Explanation: This message is for the use case when an implementation has detected a that a system has recovered from a Bus Uncorrectable Error.

May also be shown as 816f08132581xxxx or 0x816f08132581xxxx

Severity: Info

Alert Category: Critical - Other

Serviceable: No

CIM Information: Prefix: PLAT and ID: 0241

SNMP Trap ID: 50

Automatically notify Support: No

User response: No action; information only.

816f0813-2582xxxx System [ComputerSystemElementName]has recovered from an Uncorrectable Bus Error. (PCIs)

Explanation: This message is for the use case when an implementation has detected a that a system has recovered from a Bus Uncorrectable Error.

May also be shown as 816f08132582xxxx or 0x816f08132582xxxx

Severity: Info

Alert Category: Critical - Other

Serviceable: No

CIM Information: Prefix: PLAT and ID: 0241

SNMP Trap ID: 50

Automatically notify Support: No

User response: No action; information only.

816f0813-2584xxxx System [ComputerSystemElementName]has recovered from an Uncorrectable Bus Error. (CPUs)

Explanation: This message is for the use case when an implementation has detected a that a system has recovered from a Bus Uncorrectable Error.

May also be shown as 816f08132584xxxx or 0x816f08132584xxxx

Severity: Info

Alert Category: Critical - Other

Serviceable: No

CIM Information: Prefix: PLAT and ID: 0241

SNMP Trap ID: 50

Automatically notify Support: No

User response: No action; information only.

816f0a07-0301xxxx The Processor [ProcessorElementName] is no longer operating in a Degraded State. (CPU 1)

Explanation: This message is for the use case when an implementation has detected a Processor is no longer running in the Degraded state.

May also be shown as 816f0a070301xxxx or 0x816f0a070301xxxx

Severity: Info

Alert Category: Warning - CPU

Serviceable: No

CIM Information: Prefix: PLAT and ID: 0039

SNMP Trap ID: 42

Automatically notify Support: No

User response: No action; information only.

816f0a07-0302xxxx

816f0a07-0302xxxx The Processor [ProcessorElementName] is no longer operating in a Degraded State. (CPU 2)

Explanation: This message is for the use case when an implementation has detected a Processor is no longer running in the Degraded state.

May also be shown as 816f0a070302xxxx or 0x816f0a070302xxxx

Severity: Info

Alert Category: Warning - CPU

Serviceable: No

CIM Information: Prefix: PLAT and ID: 0039

SNMP Trap ID: 42

Automatically notify Support: No

User response: No action; information only.

POST

When you turn on the server, it performs a series of tests to check the operation of the server components and some optional devices in the server. This series of tests is called the power-on self-test, or POST.

If a power-on password is set, you must type the password and press Enter, when you are prompted, for POST to run.

POST error codes

The following table describes the POST error codes and suggested actions to correct the detected problems.

These errors can appear as severe, warning, or informational.

- Follow the suggested actions in the order in which they are listed in the Action column until the problem is solved.
- See Chapter 4, “Parts listing, IBM System x3550 M3 Type 4254 and 7944,” on page 333 to determine which components are customer replaceable units (CRU) and which components are field replaceable units (FRU).
- If an action step is preceded by “(Trained service technician only),” that step must be performed only by a trained service technician.
- Go to the IBM support website at <http://www.ibm.com/supportportal/> to check for technical information, hints, tips, and new device drivers or to submit a request for information.

Error code	Description	Action
0010002	Microprocessor not supported.	<ol style="list-style-type: none"> 1. Reseat the following components one at a time, in the order shown, restarting the server each time. <ol style="list-style-type: none"> a. (Trained service technician only) Microprocessor 1. b. (Trained service technician only) Microprocessor 2 (if installed.) 2. (Trained service technician only) Remove microprocessor 2 and restart the server. 3. (Trained service technician only) Remove microprocessor 1 and install microprocessor 2 in the microprocessor 1 connector. Restart the server. If the error is corrected, then microprocessor 1 is bad and must be replaced. 4. Replace the following components one at a time, in the order shown, restarting the server each time. <ol style="list-style-type: none"> a. (Trained service technician only) Microprocessor 1. b. (Trained service technician only) Microprocessor 2. c. (Trained service technician only) System board.
0011000	Invalid microprocessor type.	<ol style="list-style-type: none"> 1. Update the server firmware to the latest level (see “Updating the firmware” on page 455). 2. (Trained service technician only) Remove and replace the affected microprocessor (error LED is lit) with a supported type.
0011002	Microprocessor mismatch.	<ol style="list-style-type: none"> 1. Run the Setup utility and select System Information > System Summary > Processor Details to view the microprocessor information to compare the installed microprocessor specifications. 2. (Trained service technician only) Remove and replace one of the microprocessors so that they both match.

- Follow the suggested actions in the order in which they are listed in the Action column until the problem is solved.
- See Chapter 4, “Parts listing, IBM System x3550 M3 Type 4254 and 7944,” on page 333 to determine which components are customer replaceable units (CRU) and which components are field replaceable units (FRU).
- If an action step is preceded by “(Trained service technician only),” that step must be performed only by a trained service technician.
- Go to the IBM support website at <http://www.ibm.com/supportportal/> to check for technical information, hints, tips, and new device drivers or to submit a request for information.

Error code	Description	Action
0011004	Microprocessor failed BIST.	<ol style="list-style-type: none"> 1. Update the server firmware to the latest level (see “Updating the firmware” on page 455). 2. (Trained service technician only) Reseat microprocessor 2. 3. Replace the following components one at a time, in the order shown, restarting the server each time: <ol style="list-style-type: none"> a. (Trained service technician only) Microprocessor b. (Trained service technician only) System board
001100A	Microcode updated failed.	<ol style="list-style-type: none"> 1. Update the server firmware to the latest level (see “Updating the firmware” on page 455). 2. (Trained service technician only) Replace the microprocessor.
0018010	Microprocessors of the same model have mismatched stepping ID.	<ol style="list-style-type: none"> 1. Run the Setup utility and select System Information > System Summary > Processor Details to view the microprocessor information to compare the installed microprocessor specifications. 2. (Trained service technician only) Remove and replace one of the microprocessors so that they both match.
0018009	Microprocessors have mismatched core speed.	<ol style="list-style-type: none"> 1. Run the Setup utility and select System Information > System Summary > Processor Details to view the microprocessor information to compare the installed microprocessor specifications. 2. (Trained service technician only) Remove and replace one of the microprocessors so that they both match.
001800B	Microprocessors have one or more cache levels with mismatched size.	<ol style="list-style-type: none"> 1. Run the Setup utility and select System Information > System Summary > Processor Details to view the microprocessor information to compare the installed microprocessor specifications. 2. (Trained service technician only) Remove and replace one of the microprocessors so that they both match.

- Follow the suggested actions in the order in which they are listed in the Action column until the problem is solved.
- See Chapter 4, “Parts listing, IBM System x3550 M3 Type 4254 and 7944,” on page 333 to determine which components are customer replaceable units (CRU) and which components are field replaceable units (FRU).
- If an action step is preceded by “(Trained service technician only),” that step must be performed only by a trained service technician.
- Go to the IBM support website at <http://www.ibm.com/supportportal/> to check for technical information, hints, tips, and new device drivers or to submit a request for information.

Error code	Description	Action
0018005	Microprocessors have mismatched number of COREs.	<ol style="list-style-type: none"> 1. Run the Setup utility and select System Information > System Summary > Processor Details to view the microprocessor information to compare the installed microprocessor specifications. 2. (Trained service technician only) Remove and replace one of the microprocessors so that they both match.
0018006	Microprocessors have mismatched QPI speed.	<ol style="list-style-type: none"> 1. Run the Setup utility and select System Information > System Summary > Processor Details to view the microprocessor information to compare the installed microprocessor specifications. 2. (Trained service technician only) Remove and replace one of the microprocessors so that they both match.
0018007	Microprocessors have mismatched power segments.	<ol style="list-style-type: none"> 1. Run the Setup utility and select System Information > System Summary > Processor Details to view the microprocessor information to compare the installed microprocessor specifications. 2. (Trained service technician only) Remove and replace one of the microprocessors so that they both match.
0018008	Microprocessors have mismatched internal DDR3 frequency.	<ol style="list-style-type: none"> 1. Run the Setup utility and select System Information > System Summary > Processor Details to view the microprocessor information to compare the installed microprocessor specifications. 2. (Trained service technician only) Remove and replace one of the microprocessors so that they both match.

- Follow the suggested actions in the order in which they are listed in the Action column until the problem is solved.
- See Chapter 4, “Parts listing, IBM System x3550 M3 Type 4254 and 7944,” on page 333 to determine which components are customer replaceable units (CRU) and which components are field replaceable units (FRU).
- If an action step is preceded by “(Trained service technician only),” that step must be performed only by a trained service technician.
- Go to the IBM support website at <http://www.ibm.com/supportportal/> to check for technical information, hints, tips, and new device drivers or to submit a request for information.

Error code	Description	Action
0050001	DIMM disabled.	<p>Note: Each time you install or remove a DIMM, you must disconnect the server from the power source; then, wait 10 seconds before restarting the server.</p> <ol style="list-style-type: none"> 1. Make sure the DIMM is installed correctly (see “Installing a DIMM” on page 369). 2. If the DIMM was disabled because of a memory fault, follow the suggested actions for that error event and restart the server. 3. Check the IBM support website for an applicable retain tip or firmware update that applies to this memory event. If no memory fault is recorded in the logs and no DIMM connector error LED is lit, you can re-enable the DIMM through the Setup utility or the Advanced Settings Utility (ASU).
0051003	Uncorrectable DIMM error	<p>Note: Each time you install or remove a DIMM, you must disconnect the server from the power source; then, wait 10 seconds before restarting the server.</p> <ol style="list-style-type: none"> 1. Check the IBM support website for an applicable retain tip or firmware update that applies to this memory error. 2. Manually re-enable all affected DIMMs if the server firmware version is older than UEFI v1.10. If the server firmware version is UEFI v1.10 or newer, disconnect and reconnect the server to the power source and restart the server. 3. If the problem remains, replace the failing DIMM. 4. (Trained service technician only) If the problem occurs on the same DIMM connector, check the DIMM connector. If the connector contains any foreign material or is damaged, replace the system board. 5. (Trained service technician only) Remove the affected microprocessor and check the microprocessor socket pins for any damaged pins. If a damage is found, replace the system board. 6. (Trained Service technician only) Replace the affected microprocessor.

- Follow the suggested actions in the order in which they are listed in the Action column until the problem is solved.
- See Chapter 4, “Parts listing, IBM System x3550 M3 Type 4254 and 7944,” on page 333 to determine which components are customer replaceable units (CRU) and which components are field replaceable units (FRU).
- If an action step is preceded by “(Trained service technician only),” that step must be performed only by a trained service technician.
- Go to the IBM support website at <http://www.ibm.com/supportportal/> to check for technical information, hints, tips, and new device drivers or to submit a request for information.

Error code	Description	Action
0051004	DIMM presence detected read/write failure	<p>Note: Each time you install or remove a DIMM, you must disconnect the server from the power source; then, wait 10 seconds before restarting the server.</p> <ol style="list-style-type: none"> 1. Update the server firmware to the latest level (see “Updating the firmware” on page 455). 2. Reseat the DIMMs. 3. Install DIMMs in the correct sequence (see “Installing a DIMM” on page 369). 4. Replace the failing DIMM. 5. (Trained service technician only) Replace the system board.
0051006	DIMM mismatch detected	<p>Note: Each time you install or remove a DIMM, you must disconnect the server from the power source; then, wait 10 seconds before restarting the server. Make sure that the DIMMs match and are installed in the correct sequence (see “Installing a DIMM” on page 369).</p>
0051009	No memory detected.	<p>Note: Each time you install or remove a DIMM, you must disconnect the server from the power source; then, wait 10 seconds before restarting the server.</p> <ol style="list-style-type: none"> 1. Make sure one or more DIMMs are installed in the server. 2. Reseat the DIMMs and restart the server. 3. Make sure that the DIMMs are installed in the correct sequence (see “Installing a DIMM” on page 369 for more information). 4. (Trained service technician only) Replace the microprocessor that controls the failing DIMMs. 5. (Trained service technician only) Replace the system board.
005100A	No usable memory detected.	<p>Note: Each time you install or remove a DIMM, you must disconnect the server from the power source; then, wait 10 seconds before restarting the server.</p> <ol style="list-style-type: none"> 1. Make sure one or more DIMMs are installed in the server. 2. Reseat the DIMMs and restart the server. 3. Make sure that the DIMMs are installed in the correct sequence (see “Installing a DIMM” on page 369 for more information). 4. Clear CMOS memory to ensure that all DIMM connectors are enabled (see “System-board switches and jumpers” on page 19). Note that all firmware settings will be reset to the default settings.

- Follow the suggested actions in the order in which they are listed in the Action column until the problem is solved.
- See Chapter 4, “Parts listing, IBM System x3550 M3 Type 4254 and 7944,” on page 333 to determine which components are customer replaceable units (CRU) and which components are field replaceable units (FRU).
- If an action step is preceded by “(Trained service technician only),” that step must be performed only by a trained service technician.
- Go to the IBM support website at <http://www.ibm.com/supportportal/> to check for technical information, hints, tips, and new device drivers or to submit a request for information.

Error code	Description	Action
0058001	PFA threshold exceeded	<p>Note: Each time you install or remove a DIMM, you must disconnect the server from the power source; then, wait 10 seconds before restarting the server.</p> <ol style="list-style-type: none"> 1. Check the IBM support website for an applicable retain tip or firmware update that applies to this memory error. 2. Swap the affected DIMMs (as indicated by the error LEDs on the system board or the event logs) to a different memory channel or microprocessor (see “Installing a DIMM” on page 369 for memory population). 3. If the error still occurs on the same DIMM, replace the affected DIMM. 4. (Trained service technician only) If the problem occurs on the same DIMM connector, check the DIMM connector. If the connector contains any foreign material or is damaged, replace the system board. 5. (Trained service technician only) Remove the affected microprocessor and check the microprocessor socket pins for any damaged pins. If a damage is found, replace the system board. 6. (Trained Service technician only) Replace the affected microprocessor.
0058007	Unsupported DIMM population.	<p>Note: Each time you install or remove a DIMM, you must disconnect the server from the power source; then, wait 10 seconds before restarting the server.</p> <ol style="list-style-type: none"> 1. Reseat the DIMMs and restart the server. 2. Make sure that the DIMMs are installed in the proper sequence (see “Installing a DIMM” on page 369).

- Follow the suggested actions in the order in which they are listed in the Action column until the problem is solved.
- See Chapter 4, “Parts listing, IBM System x3550 M3 Type 4254 and 7944,” on page 333 to determine which components are customer replaceable units (CRU) and which components are field replaceable units (FRU).
- If an action step is preceded by “(Trained service technician only),” that step must be performed only by a trained service technician.
- Go to the IBM support website at <http://www.ibm.com/supportportal/> to check for technical information, hints, tips, and new device drivers or to submit a request for information.

Error code	Description	Action
0058008	DIMM failed memory test.	<p>Note: Each time you install or remove a DIMM, you must disconnect the server from the power source; then, wait 10 seconds before restarting the server.</p> <ol style="list-style-type: none"> 1. Check the IBM support website for an applicable retain tip or firmware update that applies to this memory error. 2. Manually re-enable all affected DIMMs if the server firmware version is older than UEFI v1.10. If the server firmware version is UEFI v1.10 or newer, disconnect and reconnect the server to the power source and restart the server. 3. Swap the affected DIMMs (as indicated by the error LEDs on the system board or the event logs) to a different memory channel or microprocessor (see “Installing a DIMM” on page 369 for memory population). 4. If the problem is related to a DIMM, replace the failing DIMM. 5. (Trained service technician only) If the problem occurs on the same DIMM connector, check the DIMM connector. If the connector contains any foreign material or is damaged, replace the system board. 6. (Trained service technician only) Remove the affected microprocessor and check the microprocessor socket pins for any damaged pins. If a damage is found, replace the system board. 7. (Trained service technician only) If the problem is related to microprocessor socket pins, replace the system board. 8. (Trained Service technician only) Replace the affected microprocessor.
0058015	Start to activate spare memory channel	Information only. A failed DIMM has been detected to activate the memory online-spare feature. Check the event log for uncorrected DIMM failure events.
00580A1	Invalid DIMM population for mirroring mode	<p>Note: Each time you install or remove a DIMM, you must disconnect the server from the power source; then, wait 10 seconds before restarting the server.</p> <ol style="list-style-type: none"> 1. If a fault LED is lit, resolve the failure. 2. Install the DIMMs in the correct sequence (see “Installing a DIMM” on page 369).
00580A4	Memory population changed.	Information only. Memory has been added, moved, or changed.

- Follow the suggested actions in the order in which they are listed in the Action column until the problem is solved.
- See Chapter 4, “Parts listing, IBM System x3550 M3 Type 4254 and 7944,” on page 333 to determine which components are customer replaceable units (CRU) and which components are field replaceable units (FRU).
- If an action step is preceded by “(Trained service technician only),” that step must be performed only by a trained service technician.
- Go to the IBM support website at <http://www.ibm.com/supportportal/> to check for technical information, hints, tips, and new device drivers or to submit a request for information.

Error code	Description	Action
00580A5	Mirror failover complete	Information only. Memory redundancy has been lost. Check the event log for uncorrected DIMM failure events (see “Event logs” on page 27).
00580A6	Spare memory channel activated	Information only. Memory online-spare channel has been activated to back up a failed DIMM. Check the event log for uncorrected DIMM failure events.
0068002	CMOS battery cleared.	<ol style="list-style-type: none"> 1. Reseat the battery. 2. Clear the CMOS memory (see “System-board switches and jumpers” on page 19). 3. Replace the following components one at a time, in the following order, restarting the server after each one: <ol style="list-style-type: none"> a. Battery b. (Trained service technician only) System board.
2011001	PCI-X SERR	<ol style="list-style-type: none"> 1. Check the riser-card LEDs. 2. Reseat all affected adapters and riser cards. 3. Update the PCI adapter firmware. 4. Remove the adapter from the riser card. 5. Replace the following components one at a time, in the order shown, restarting the server each time: <ol style="list-style-type: none"> a. Riser card b. (Trained service technician only) System board
2018001	PCI Express uncorrected or uncorrected error	<ol style="list-style-type: none"> 1. Check the riser-card LEDs. 2. Reseat all affected adapters and riser cards. 3. Update the PCI adapter firmware. 4. Remove the adapter from the riser card. 5. Replace the following components one at a time, in the order shown, restarting the server each time: <ol style="list-style-type: none"> a. Riser card b. (Trained service technician only) System board

- Follow the suggested actions in the order in which they are listed in the Action column until the problem is solved.
- See Chapter 4, “Parts listing, IBM System x3550 M3 Type 4254 and 7944,” on page 333 to determine which components are customer replaceable units (CRU) and which components are field replaceable units (FRU).
- If an action step is preceded by “(Trained service technician only),” that step must be performed only by a trained service technician.
- Go to the IBM support website at <http://www.ibm.com/supportportal/> to check for technical information, hints, tips, and new device drivers or to submit a request for information.

Error code	Description	Action
2018002	Option ROM resource allocation failure	<p>Informational message that some devices might not be initialized.</p> <ol style="list-style-type: none"> 1. If possible, rearrange the order of the adapters in the PCI slots to change the load order of the optional-device ROM code. 2. Run the Setup utility, select Startup Options, and change the boot priority to change the load order of the optional-device ROM code. 3. Run the Setup utility and disable some other resources, if their functions are not being used, to make more space available. <ol style="list-style-type: none"> a. Select Startup Options > Planar Ethernet (PXE/DHCP) to disable the integrated Ethernet controller ROM. b. Select Advanced Functions > PCI Bus Control > PCI ROM Control Execution to disable the ROM of the adapter in the PCI slots. c. Select Devices and I/O Ports to disable any of the integrated devices. 4. Replace the following components one at a time, in the order shown, restarting the server each time: <ol style="list-style-type: none"> a. Each adapter b. (Trained service technician only) System board
3xx0007 (xx can be 00 - 19)	Firmware fault detected, system halted	<ol style="list-style-type: none"> 1. Recover the server firmware to the latest level. 2. Undo any recent configuration changes, or clear CMOS memory to restore the settings to the default values (see “System-board switches and jumpers” on page 19). 3. Remove any recently installed hardware.
3038003	Firmware corrupted	<ol style="list-style-type: none"> 1. Run the Setup utility, select Load Default Settings, and save the settings to recover the server firmware. 2. (Trained service technician only) Replace the system board.
3048005	Booted secondary (backup) UEFI Image	Information only. The backup switch was used to boot the secondary bank.

- Follow the suggested actions in the order in which they are listed in the Action column until the problem is solved.
- See Chapter 4, “Parts listing, IBM System x3550 M3 Type 4254 and 7944,” on page 333 to determine which components are customer replaceable units (CRU) and which components are field replaceable units (FRU).
- If an action step is preceded by “(Trained service technician only),” that step must be performed only by a trained service technician.
- Go to the IBM support website at <http://www.ibm.com/supportportal/> to check for technical information, hints, tips, and new device drivers or to submit a request for information.

Error code	Description	Action
3048006	Booted secondary (backup) UEFI image because of ABR	<ol style="list-style-type: none"> 1. Run the Setup utility, select Load Default Settings, and save the settings to recover the primary UEFI settings. 2. Turn off the server and remove it from the power source. 3. Reconnect the server to the power source, then turn on the server.
305000A	RTC date/time is incorrect	<ol style="list-style-type: none"> 1. Adjust the date and time settings in the Setup utility, and then restart the server. 2. Reseat the battery. 3. Replace the following components one at a time, in the order shown, restarting the server each time: <ol style="list-style-type: none"> a. Battery b. (Trained service technician only) System board
3058001	System configuration invalid	<ol style="list-style-type: none"> 1. Run the Setup utility, and select Save Settings. 2. Run the Setup utility, select Load Default Settings, and save the settings. 3. Reseat the following components one at a time in the order shown, restarting the server each time: <ol style="list-style-type: none"> a. Battery b. Failing device (if the device is a FRU, then it must be reseated by a trained service technician only) 4. Replace the following components one at a time, in the order shown, restarting the server each time: <ol style="list-style-type: none"> a. Battery b. Failing device (if the device is a FRU, then it must be replaced by a trained service technician only) c. (Trained service technician only) System board

- Follow the suggested actions in the order in which they are listed in the Action column until the problem is solved.
- See Chapter 4, “Parts listing, IBM System x3550 M3 Type 4254 and 7944,” on page 333 to determine which components are customer replaceable units (CRU) and which components are field replaceable units (FRU).
- If an action step is preceded by “(Trained service technician only),” that step must be performed only by a trained service technician.
- Go to the IBM support website at <http://www.ibm.com/supportportal/> to check for technical information, hints, tips, and new device drivers or to submit a request for information.

Error code	Description	Action
3058004	Three boot failure	<ol style="list-style-type: none"> 1. Undo any recent system changes, such as new settings or newly installed devices. 2. Make sure that the server is attached to a reliable power source. 3. Remove all hardware that is not listed on the ServerProven website at http://www.ibm.com/systems/info/x86servers/serverproven/compat/us/. 4. Make sure that the operating system is not corrupted. 5. Run the Setup utility, save the configuration, and then restart the server. 6. See “Problem determination tips” on page 330.
3108007	System configuration restored to default settings	Information only. This message is usually associated with the CMOS battery clear event.
3138002	Boot configuration error	<ol style="list-style-type: none"> 1. Remove any recent configuration changes made to the Setup utility. 2. Run the Setup utility, select Load Default Settings, and save the settings.
3808000	IMM communication failure	<ol style="list-style-type: none"> 1. Shut down the system and remove the power cords from the server for 30 seconds; then, reconnect the server to power and restart it. 2. Update the IMM firmware to the latest level (see “Updating the firmware” on page 455). 3. Make sure that the virtual media key is seated and not damaged. 4. (Trained service technician only) Replace the system board.
3808002	Error updating system configuration to IMM	<ol style="list-style-type: none"> 1. Shut down the system and remove the power cords from the server; then, reconnect the server to power and restart it. 2. Run the Setup utility and select Save Settings. 3. Update the IMM firmware to the latest level (see “Updating the firmware” on page 455).
3808003	Error retrieving system configuration from IMM	<ol style="list-style-type: none"> 1. Shut down the system and remove the power cords from the server; then, reconnect the server to power and restart it. 2. Run the Setup utility and select Save Settings. 3. Update the IMM firmware to the latest level (see “Updating the firmware” on page 455).

- Follow the suggested actions in the order in which they are listed in the Action column until the problem is solved.
- See Chapter 4, “Parts listing, IBM System x3550 M3 Type 4254 and 7944,” on page 333 to determine which components are customer replaceable units (CRU) and which components are field replaceable units (FRU).
- If an action step is preceded by “(Trained service technician only),” that step must be performed only by a trained service technician.
- Go to the IBM support website at <http://www.ibm.com/supportportal/> to check for technical information, hints, tips, and new device drivers or to submit a request for information.

Error code	Description	Action
3808004	IMM system event log full	<ul style="list-style-type: none"> • When using out-of-band, use the IMM Web interface or IPMItool to clear the logs from the operating system. • When using the local console: <ol style="list-style-type: none"> 1. Run the Setup utility. 2. Select System Event Log > Clear System Event Log. 3. Restart the server.
3818001	Core Root of Trust Measurement (CRTM) update failed	<ol style="list-style-type: none"> 1. Run the Setup utility, select Load Default Settings, and save the settings. 2. (Trained service technician only) Replace the system board.
3818002	Core Root of Trust Measurement (CRTM) update aborted	<ol style="list-style-type: none"> 1. Run the Setup utility, select Load Default Settings, and save the settings. 2. (Trained service technician only) Replace the system board.
3818003	Core Root of Trust Measurement (CRTM) flash lock failed	<ol style="list-style-type: none"> 1. Run the Setup utility, select Load Default Settings, and save the settings. 2. (Trained service technician only) Replace the system board.
3818004	Core Root of Trust Measurement (CRTM) system error	<ol style="list-style-type: none"> 1. Run the Setup utility, select Load Default Settings, and save the settings. 2. (Trained service technician only) Replace the system board.
3818005	Current Bank Core Root of Trust Measurement (CRTM) capsule signature invalid	<ol style="list-style-type: none"> 1. Run the Setup utility, select Load Default Settings, and save the settings. 2. (Trained service technician only) Replace the system board.
3818006	Opposite bank CRTM capsule signature invalid	<ol style="list-style-type: none"> 1. Switch the server firmware bank to the backup bank (see “Starting the backup server firmware” on page 466). 2. Run the Setup utility, select Load Default Settings, and save the settings. 3. Switch the bank back to the primary bank. 4. (Trained service technician only) Replace the system board.
3818007	CRTM update capsule signature invalid	<ol style="list-style-type: none"> 1. Run the Setup utility, select Load Default Settings, and save the settings. 2. (Trained service technician only) Replace the system board.

- Follow the suggested actions in the order in which they are listed in the Action column until the problem is solved.
- See Chapter 4, “Parts listing, IBM System x3550 M3 Type 4254 and 7944,” on page 333 to determine which components are customer replaceable units (CRU) and which components are field replaceable units (FRU).
- If an action step is preceded by “(Trained service technician only),” that step must be performed only by a trained service technician.
- Go to the IBM support website at <http://www.ibm.com/supportportal/> to check for technical information, hints, tips, and new device drivers or to submit a request for information.

Error code	Description	Action
3828004	AEM power capping disabled	<ol style="list-style-type: none"> 1. Check the settings and the event logs. 2. Make sure that the Active Energy Manager feature is enabled in the Setup utility. Select System Settings > Power > Active Energy > Capping Enabled. 3. Update the server firmware to the latest level (see “Updating the firmware” on page 455). 4. Update the IMM firmware to the latest level (see “Updating the firmware” on page 455).

Diagnostic programs and messages

The diagnostic programs are the primary method of testing the major components of the server. As you run the diagnostic programs, text messages are displayed on the screen and are saved in the test log. A diagnostic text message indicates that a problem has been detected and provides the action you should take as a result of the text message.

Make sure that the server has the latest version of the diagnostic programs. To download the latest version, go to <http://www.ibm.com/support/entry/portal/docdisplay?Indocid=SERV-DSA>.

Utilities are available to reset and update the diagnostics code on the integrated USB flash device, if the diagnostic partition becomes damaged and does not start the diagnostic programs. For more information and to download the utilities, go to <http://www.ibm.com/support/entry/portal/docdisplay?Indocid=SERV-DSA>.

Running the diagnostic programs

Use this information to run the diagnostic programs.

About this task

Note: The DSA memory test might take up to 30 minutes to run. If the problem is not a memory problem, skip the memory test.

To run the diagnostic programs, complete the following steps:

Procedure

1. If the server is running, turn off the server and all attached devices.
2. Turn on all attached devices; then, turn on the server.
3. When the prompt <F2> Dynamic System Analysis is displayed, press F2.

Note: The DSA Preboot diagnostic program might appear to be unresponsive for an unusual length of time when you start the program. This is normal operation while the program loads. The loading process may take up to 10 minutes.

4. Optionally, select **Quit to DSA** to exit from the stand-alone memory diagnostic program.

Note: After you exit from the stand-alone memory diagnostic environment, you must restart the server to access the stand-alone memory diagnostic environment again.

5. Type **gui** to display the graphical user interface, or type **cmd** to display the DSA interactive menu.
6. Follow the instructions on the screen to select the diagnostic test to run.

Results

If the diagnostic programs do not detect any hardware errors but the problem remains during normal server operation, a software error might be the cause. If you suspect a software problem, see the information that comes with your software.

A single problem might cause more than one error message. When this happens, correct the cause of the first error message. The other error messages usually will not occur the next time you run the diagnostic programs.

Exception: If multiple error codes or light path diagnostics LEDs indicate a microprocessor error, the error might be in a microprocessor or in a microprocessor socket. See “Microprocessor problems” on page 300 for information about diagnosing microprocessor problems.

If the server stops during testing and you cannot continue, restart the server and try running the diagnostic programs again. If the problem remains, replace the component that was being tested when the server stopped.

Diagnostic text messages

Diagnostic text messages are displayed while the tests are running.

A diagnostic text message contains one of the following results:

Passed: The test was completed without any errors.

Failed: The test detected an error.

Aborted: The test could not proceed because of the server configuration.

Additional information concerning test failures is available in the extended diagnostic results for each test.

Viewing the test log

Use this information to view the test log results.

About this task

To view the test log when the tests are completed, type the **view** command in the DSA interactive menu, or select **Diagnostic Event Log** in the graphical user interface. To transfer DSA Preboot collections to an external USB device, type the copy command in the DSA interactive menu.

Diagnostic messages

The following table describes the messages that the diagnostic programs might generate and suggested actions to correct the detected problems.

Follow the suggested actions in the order in which they are listed in the column.

Table 9. DSA Preboot messages

<ul style="list-style-type: none">• Follow the suggested actions in the order in which they are listed in the Action column until the problem is solved.• See Chapter 4, "Parts listing, IBM System x3550 M3 Type 4254 and 7944," on page 333 to determine which components are customer replaceable units (CRU) and which components are field replaceable units (FRU).• If an action step is preceded by "(Trained service technician only)", that step must be performed only by a Trained service technician.• Go to the IBM support website at http://www.ibm.com/supportportal/ to check for technical information, hints, tips, and new device drivers or to submit a request for information.					
Message number	Component	Test	State	Description	Action
089-801-xxx	CPU	CPU Stress Test	Aborted	Internal program error.	<ol style="list-style-type: none">1. Turn off and restart the system.2. Make sure that the DSA code is at the latest level. For the latest level of DSA code, go to http://www.ibm.com/support/entry/portal/docdisplay?Indocid=SERV-DSA.3. Run the test again.4. Make sure that the system firmware is at the latest level. The installed firmware level is shown in the DSA event log in the Firmware/VPD section for this component. For more information, see "Updating the firmware" on page 455.5. Run the test again.6. Turn off and restart the system if necessary to recover from a hung state.7. Run the test again.8. If the failure remains, go to the IBM website for more troubleshooting information at http://www.ibm.com/support/entry/portal/docdisplay?Indocid=SERV-CALL.

Table 9. DSA Preboot messages (continued)

<ul style="list-style-type: none"> Follow the suggested actions in the order in which they are listed in the Action column until the problem is solved. See Chapter 4, "Parts listing, IBM System x3550 M3 Type 4254 and 7944," on page 333 to determine which components are customer replaceable units (CRU) and which components are field replaceable units (FRU). If an action step is preceded by "(Trained service technician only)", that step must be performed only by a Trained service technician. Go to the IBM support website at http://www.ibm.com/supportportal/ to check for technical information, hints, tips, and new device drivers or to submit a request for information. 					
Message number	Component	Test	State	Description	Action
089-802-xxx	CPU	CPU Stress Test	Aborted	System resource availability error.	<ol style="list-style-type: none"> Turn off and restart the system. Make sure that the DSA code is at the latest level. For the latest level of DSA code, go to http://www.ibm.com/support/entry/portal/docdisplay?Indocid=SERV-DSA. Run the test again. Make sure that the system firmware is at the latest level. The installed firmware level is shown in the DSA event log in the Firmware/VPD section for this component. For the latest level of firmware, go to http://www.ibm.com/support/fixcentral/ and select your system to display a matrix of available firmware. Run the test again. Turn off and restart the system if necessary to recover from a hung state. Run the test again. Make sure that the system firmware is at the latest level. The installed firmware level is shown in the DSA event log in the Firmware/VPD section for this component. For more information, see "Updating the firmware" on page 455. Run the test again. If the failure remains, go to the IBM website for more troubleshooting information at http://www.ibm.com/support/entry/portal/docdisplay?Indocid=SERV-CALL.

Table 9. DSA Preboot messages (continued)

Message number	Component	Test	State	Description	Action
089-901-xxx	CPU	CPU Stress Test	Failed	Test failure.	<ul style="list-style-type: none"> 1. Turn off and restart the system if necessary to recover from a hung state. 2. Make sure that the DSA code is at the latest level. For the latest level of DSA code, go to http://www.ibm.com/support/entry/portal/docdisplay?lnocid=SERV-DSA. 3. Run the test again. 4. Make sure that the system firmware is at the latest level. The installed firmware level is shown in the DSA event log in the Firmware/VPD section for this component. For more information, see "Updating the firmware" on page 455. 5. Run the test again. 6. Turn off and restart the system if necessary to recover from a hung state. 7. Run the test again. 8. If the failure remains, go to the IBM website for more troubleshooting information at http://www.ibm.com/support/entry/portal/docdisplay?lnocid=SERV-CALL.
166-801-xxx	IMM	IMM I2C Test	Aborted	IMM I2C test aborted: the IMM returned an incorrect response length.	<ul style="list-style-type: none"> 1. Turn off the system and disconnect it from the power source. You must disconnect the system from ac power to reset the IMM. 2. After 45 seconds, reconnect the system to the power source and turn on the system. 3. Run the test again. 4. Make sure that the DSA code is at the latest level. For the latest level of DSA code, go to http://www.ibm.com/support/entry/portal/docdisplay?lnocid=SERV-DSA. 5. Make sure that the IMM firmware is at the latest level. The installed firmware level is shown in the DSA event log in the Firmware/VPD section for this component. For more information, see "Updating the firmware" on page 455. 6. Run the test again. 7. If the failure remains, go to the IBM website for more troubleshooting information at http://www.ibm.com/support/entry/portal/docdisplay?lnocid=SERV-CALL.

Table 9. DSA Preboot messages (continued)

<ul style="list-style-type: none"> • Follow the suggested actions in the order in which they are listed in the Action column until the problem is solved. • See Chapter 4, "Parts listing, IBM System x3550 M3 Type 4254 and 7944," on page 333 to determine which components are customer replaceable units (CRU) and which components are field replaceable units (FRU). • If an action step is preceded by "(Trained service technician only)", that step must be performed only by a Trained service technician. • Go to the IBM support website at http://www.ibm.com/supportportal/ to check for technical information, hints, tips, and new device drivers or to submit a request for information. 					
Message number	Component	Test	State	Description	Action
166-802-xxx	IMM	IMM I2C Test	Aborted	IMM I2C test aborted: the test cannot be completed for an unknown reason.	<ol style="list-style-type: none"> 1. Turn off the system and disconnect it from the power source. You must disconnect the system from ac power to reset the IMM. 2. After 45 seconds, reconnect the system to the power source and turn on the system. 3. Run the test again. 4. Make sure that the DSA code is at the latest level. For the latest level of DSA code, go to http://www.ibm.com/support/entry/portal/docdisplay?Indocid=SERV-DSA. 5. Make sure that the IMM firmware is at the latest level. The installed firmware level is shown in the DSA event log in the Firmware/VPD section for this component. For more information, see "Updating the firmware" on page 455. 6. Run the test again. 7. If the failure remains, go to the IBM website for more troubleshooting information at http://www.ibm.com/support/entry/portal/docdisplay?Indocid=SERV-CALL.
166-803-xxx	IMM	IMM I2C Test	Aborted	IMM I2C test aborted: the node is busy; try later.	<ol style="list-style-type: none"> 1. Turn off the system and disconnect it from the power source. You must disconnect the system from ac power to reset the IMM. 2. After 45 seconds, reconnect the system to the power source and turn on the system. 3. Run the test again. 4. Make sure that the DSA code is at the latest level. For the latest level of DSA code, go to http://www.ibm.com/support/entry/portal/docdisplay?Indocid=SERV-DSA. 5. Make sure that the IMM firmware is at the latest level. The installed firmware level is shown in the DSA event log in the Firmware/VPD section for this component. For more information, see "Updating the firmware" on page 455. 6. Run the test again. 7. If the failure remains, go to the IBM website for more troubleshooting information at http://www.ibm.com/support/entry/portal/docdisplay?Indocid=SERV-CALL.

Table 9. DSA Preboot messages (continued)

Message number	Component	Test	State	Description	Action
166-804-xxx	IMM	IMM I2C Test	Aborted	IMM I2C test aborted: invalid command.	<ul style="list-style-type: none"> 1. Turn off the system and disconnect it from the power source. You must disconnect the system from ac power to reset the IMM. 2. After 45 seconds, reconnect the system to the power source and turn on the system. 3. Run the test again. 4. Make sure that the DSA code is at the latest level. For the latest level of DSA code, go to http://www.ibm.com/support/entry/portal/docdisplay?Indocid=SERV-DSA. 5. Make sure that the IMM firmware is at the latest level. The installed firmware level is shown in the DSA event log in the Firmware/VPD section for this component. For more information, see "Updating the firmware" on page 455. 6. Run the test again. 7. If the failure remains, go to the IBM website for more troubleshooting information at http://www.ibm.com/support/entry/portal/docdisplay?Indocid=SERV-CALL.
166-805-xxx	IMM	IMM I2C Test	Aborted	IMM I2C test aborted: invalid command for the given LUN.	<ul style="list-style-type: none"> 1. Turn off the system and disconnect it from the power source. You must disconnect the system from ac power to reset the IMM. 2. After 45 seconds, reconnect the system to the power source and turn on the system. 3. Run the test again. 4. Make sure that the DSA code is at the latest level. For the latest level of DSA code, go to http://www.ibm.com/support/entry/portal/docdisplay?Indocid=SERV-DSA. 5. Make sure that the IMM firmware is at the latest level. The installed firmware level is shown in the DSA event log in the Firmware/VPD section for this component. For more information, see "Updating the firmware" on page 455. 6. Run the test again. 7. If the failure remains, go to the IBM website for more troubleshooting information at http://www.ibm.com/support/entry/portal/docdisplay?Indocid=SERV-CALL.

Table 9. DSA Preboot messages (continued)

Message number	Component	Test	State	Description	Action
166-806-xxx	IMM	IMM I2C Test	Aborted	IMM I2C test aborted: timeout while processing the command.	<ul style="list-style-type: none"> 1. Turn off the system and disconnect it from the power source. You must disconnect the system from ac power to reset the IMM. 2. After 45 seconds, reconnect the system to the power source and turn on the system. 3. Run the test again. 4. Make sure that the DSA code is at the latest level. For the latest level of DSA code, go to http://www.ibm.com/support/entry/portal/docdisplay?Indocid=SERV-DSA. 5. Make sure that the IMM firmware is at the latest level. The installed firmware level is shown in the DSA event log in the Firmware/VPD section for this component. For more information, see "Updating the firmware" on page 455. 6. Run the test again. 7. If the failure remains, go to the IBM website for more troubleshooting information at http://www.ibm.com/support/entry/portal/docdisplay?Indocid=SERV-CALL.
166-807-xxx	IMM	IMM I2C Test	Aborted	IMM I2C test aborted: out of space.	<ul style="list-style-type: none"> 1. Turn off the system and disconnect it from the power source. You must disconnect the system from ac power to reset the IMM. 2. After 45 seconds, reconnect the system to the power source and turn on the system. 3. Run the test again. 4. Make sure that the DSA code is at the latest level. For the latest level of DSA code, go to http://www.ibm.com/support/entry/portal/docdisplay?Indocid=SERV-DSA. 5. Make sure that the IMM firmware is at the latest level. The installed firmware level is shown in the DSA event log in the Firmware/VPD section for this component. For more information, see "Updating the firmware" on page 455. 6. Run the test again. 7. If the failure remains, go to the IBM website for more troubleshooting information at http://www.ibm.com/support/entry/portal/docdisplay?Indocid=SERV-CALL.

Table 9. DSA Preboot messages (continued)

Message number	Component	Test	State	Description	Action
166-808-xxx	IMM	IMM I2C Test	Aborted	IMM I2C test aborted: reservation canceled or invalid reservation ID.	<ul style="list-style-type: none"> 1. Turn off the system and disconnect it from the power source. You must disconnect the system from ac power to reset the IMM. 2. After 45 seconds, reconnect the system to the power source and turn on the system. 3. Run the test again. 4. Make sure that the DSA code is at the latest level. For the latest level of DSA code, go to http://www.ibm.com/support/entry/portal/docdisplay?Indocid=SERV-DSA. 5. Make sure that the IMM firmware is at the latest level. The installed firmware level is shown in the DSA event log in the Firmware/VPD section for this component. For more information, see "Updating the firmware" on page 455. 6. Run the test again. 7. If the failure remains, go to the IBM website for more troubleshooting information at http://www.ibm.com/support/entry/portal/docdisplay?Indocid=SERV-CALL.
166-809-xxx	IMM	IMM I2C Test	Aborted	IMM I2C test aborted: request data was truncated.	<ul style="list-style-type: none"> 1. Turn off the system and disconnect it from the power source. You must disconnect the system from ac power to reset the IMM. 2. After 45 seconds, reconnect the system to the power source and turn on the system. 3. Run the test again. 4. Make sure that the DSA code is at the latest level. For the latest level of DSA code, go to http://www.ibm.com/support/entry/portal/docdisplay?Indocid=SERV-DSA. 5. Make sure that the IMM firmware is at the latest level. The installed firmware level is shown in the DSA event log in the Firmware/VPD section for this component. For more information, see "Updating the firmware" on page 455. 6. Run the test again. 7. If the failure remains, go to the IBM website for more troubleshooting information at http://www.ibm.com/support/entry/portal/docdisplay?Indocid=SERV-CALL.

Table 9. DSA Preboot messages (continued)

Message number	Component	Test	State	Description	Action
166-810-xxx	IMM	IMM I2C Test	Aborted	IMM I2C test aborted: request data length is invalid.	<ul style="list-style-type: none"> 1. Turn off the system and disconnect it from the power source. You must disconnect the system from ac power to reset the IMM. 2. After 45 seconds, reconnect the system to the power source and turn on the system. 3. Run the test again. 4. Make sure that the DSA code is at the latest level. For the latest level of DSA code, go to http://www.ibm.com/support/entry/portal/docdisplay?Indocid=SERV-DSA. 5. Make sure that the IMM firmware is at the latest level. The installed firmware level is shown in the DSA event log in the Firmware/VPD section for this component. For more information, see "Updating the firmware" on page 455. 6. Run the test again. 7. If the failure remains, go to the IBM website for more troubleshooting information at http://www.ibm.com/support/entry/portal/docdisplay?Indocid=SERV-CALL.
166-811-xxx	IMM	IMM I2C Test	Aborted	IMM I2C test aborted: request data field length limit is exceeded.	<ul style="list-style-type: none"> 1. Turn off the system and disconnect it from the power source. You must disconnect the system from ac power to reset the IMM. 2. After 45 seconds, reconnect the system to the power source and turn on the system. 3. Run the test again. 4. Make sure that the DSA code is at the latest level. For the latest level of DSA code, go to http://www.ibm.com/support/entry/portal/docdisplay?Indocid=SERV-DSA. 5. Make sure that the IMM firmware is at the latest level. The installed firmware level is shown in the DSA event log in the Firmware/VPD section for this component. For more information, see "Updating the firmware" on page 455. 6. Run the test again. 7. If the failure remains, go to the IBM website for more troubleshooting information at http://www.ibm.com/support/entry/portal/docdisplay?Indocid=SERV-CALL.

Table 9. DSA Preboot messages (continued)

Message number	Component	Test	State	Description	Action
166-812-xxx	IMM	IMM I2C Test	Aborted	IMM I2C Test aborted: a parameter is out of range.	<ul style="list-style-type: none"> 1. Turn off the system and disconnect it from the power source. You must disconnect the system from ac power to reset the IMM. 2. After 45 seconds, reconnect the system to the power source and turn on the system. 3. Run the test again. 4. Make sure that the DSA code is at the latest level. For the latest level of DSA code, go to http://www.ibm.com/support/entry/portal/docdisplay?Indocid=SERV-DSA. 5. Make sure that the IMM firmware is at the latest level. The installed firmware level is shown in the DSA event log in the Firmware/VPD section for this component. For more information, see "Updating the firmware" on page 455. 6. Run the test again. 7. If the failure remains, go to the IBM website for more troubleshooting information at http://www.ibm.com/support/entry/portal/docdisplay?Indocid=SERV-CALL.
166-813-xxx	IMM	IMM I2C Test	Aborted	IMM I2C test aborted: cannot return the number of requested data bytes.	<ul style="list-style-type: none"> 1. Turn off the system and disconnect it from the power source. You must disconnect the system from ac power to reset the IMM. 2. After 45 seconds, reconnect the system to the power source and turn on the system. 3. Run the test again. 4. Make sure that the DSA code is at the latest level. For the latest level of DSA code, go to http://www.ibm.com/support/entry/portal/docdisplay?Indocid=SERV-DSA. 5. Make sure that the IMM firmware is at the latest level. The installed firmware level is shown in the DSA event log in the Firmware/VPD section for this component. For more information, see "Updating the firmware" on page 455. 6. Run the test again. 7. If the failure remains, go to the IBM website for more troubleshooting information at http://www.ibm.com/support/entry/portal/docdisplay?Indocid=SERV-CALL.

Table 9. DSA Preboot messages (continued)

Message number	Component	Test	State	Description	Action
166-814-xxx	IMM	IMM I2C Test	Aborted	IMM I2C test aborted: requested sensor, data, or record is not present.	<ul style="list-style-type: none"> 1. Turn off the system and disconnect it from the power source. You must disconnect the system from ac power to reset the IMM. 2. After 45 seconds, reconnect the system to the power source and turn on the system. 3. Run the test again. 4. Make sure that the DSA code is at the latest level. For the latest level of DSA code, go to http://www.ibm.com/support/entry/portal/docdisplay?Indocid=SERV-DSA. 5. Make sure that the IMM firmware is at the latest level. The installed firmware level is shown in the DSA event log in the Firmware/VPD section for this component. For more information, see "Updating the firmware" on page 455. 6. Run the test again. 7. If the failure remains, go to the IBM website for more troubleshooting information at http://www.ibm.com/support/entry/portal/docdisplay?Indocid=SERV-CALL.
166-815-xxx	IMM	IMM I2C Test	Aborted	IMM I2C test aborted: invalid data field in the request.	<ul style="list-style-type: none"> 1. Turn off the system and disconnect it from the power source. You must disconnect the system from ac power to reset the IMM. 2. After 45 seconds, reconnect the system to the power source and turn on the system. 3. Run the test again. 4. Make sure that the DSA code is at the latest level. For the latest level of DSA code, go to http://www.ibm.com/support/entry/portal/docdisplay?Indocid=SERV-DSA. 5. Make sure that the IMM firmware is at the latest level. The installed firmware level is shown in the DSA event log in the Firmware/VPD section for this component. For more information, see "Updating the firmware" on page 455. 6. Run the test again. 7. If the failure remains, go to the IBM website for more troubleshooting information at http://www.ibm.com/support/entry/portal/docdisplay?Indocid=SERV-CALL.

Table 9. DSA Preboot messages (continued)

Message number	Component	Test	State	Description	Action
166-816-xxx	IMM	IMM I2C Test	Aborted	IMM I2C test aborted: the command is illegal for the specified sensor or record type.	<ul style="list-style-type: none"> 1. Turn off the system and disconnect it from the power source. You must disconnect the system from ac power to reset the IMM. 2. After 45 seconds, reconnect the system to the power source and turn on the system. 3. Run the test again. 4. Make sure that the DSA code is at the latest level. For the latest level of DSA code, go to http://www.ibm.com/support/entry/portal/docdisplay?Indocid=SERV-DSA. 5. Make sure that the IMM firmware is at the latest level. The installed firmware level is shown in the DSA event log in the Firmware/VPD section for this component. For more information, see "Updating the firmware" on page 455. 6. Run the test again. 7. If the failure remains, go to the IBM website for more troubleshooting information at http://www.ibm.com/support/entry/portal/docdisplay?Indocid=SERV-CALL.
166-817-xxx	IMM	IMM I2C Test	Aborted	IMM I2C test aborted: a command response could not be provided.	<ul style="list-style-type: none"> 1. Turn off the system and disconnect it from the power source. You must disconnect the system from ac power to reset the IMM. 2. After 45 seconds, reconnect the system to the power source and turn on the system. 3. Run the test again. 4. Make sure that the DSA code is at the latest level. For the latest level of DSA code, go to http://www.ibm.com/support/entry/portal/docdisplay?Indocid=SERV-DSA. 5. Make sure that the IMM firmware is at the latest level. The installed firmware level is shown in the DSA event log in the Firmware/VPD section for this component. For more information, see "Updating the firmware" on page 455. 6. Run the test again. 7. If the failure remains, go to the IBM website for more troubleshooting information at http://www.ibm.com/support/entry/portal/docdisplay?Indocid=SERV-CALL.

Table 9. DSA Preboot messages (continued)

<ul style="list-style-type: none"> Follow the suggested actions in the order in which they are listed in the Action column until the problem is solved. See Chapter 4, "Parts listing, IBM System x3550 M3 Type 4254 and 7944," on page 333 to determine which components are customer replaceable units (CRU) and which components are field replaceable units (FRU). If an action step is preceded by "(Trained service technician only)", that step must be performed only by a Trained service technician. Go to the IBM support website at http://www.ibm.com/supportportal/ to check for technical information, hints, tips, and new device drivers or to submit a request for information. 					
Message number	Component	Test	State	Description	Action
166-818-xxx	IMM	IMM I2C Test	Aborted	IMM I2C test aborted: cannot execute a duplicated request.	<ol style="list-style-type: none"> Turn off the system and disconnect it from the power source. You must disconnect the system from ac power to reset the IMM. After 45 seconds, reconnect the system to the power source and turn on the system. Run the test again. Make sure that the DSA code is at the latest level. For the latest level of DSA code, go to http://www.ibm.com/support/entry/portal/docdisplay?Indocid=SERV-DSA. Make sure that the IMM firmware is at the latest level. The installed firmware level is shown in the DSA event log in the Firmware/VPD section for this component. For more information, see "Updating the firmware" on page 455. Run the test again. If the failure remains, go to the IBM website for more troubleshooting information at http://www.ibm.com/support/entry/portal/docdisplay?Indocid=SERV-CALL.
166-819-xxx	IMM	IMM I2C Test	Aborted	IMM I2C test aborted: a command response could not be provided; the SDR repository is in update mode.	<ol style="list-style-type: none"> Turn off the system and disconnect it from the power source. You must disconnect the system from ac power to reset the IMM. After 45 seconds, reconnect the system to the power source and turn on the system. Run the test again. Make sure that the DSA code is at the latest level. For the latest level of DSA code, go to http://www.ibm.com/support/entry/portal/docdisplay?Indocid=SERV-DSA. Make sure that the IMM firmware is at the latest level. The installed firmware level is shown in the DSA event log in the Firmware/VPD section for this component. For more information, see "Updating the firmware" on page 455. Run the test again. If the failure remains, go to the IBM website for more troubleshooting information at http://www.ibm.com/support/entry/portal/docdisplay?Indocid=SERV-CALL.

Table 9. DSA Preboot messages (continued)

Message number	Component	Test	State	Description	Action
166-820-xxx	IMM	IMM I2C Test	Aborted	IMM I2C test aborted: a command response could not be provided; the device is in firmware update mode.	<ul style="list-style-type: none"> 1. Turn off the system and disconnect it from the power source. You must disconnect the system from ac power to reset the IMM. 2. After 45 seconds, reconnect the system to the power source and turn on the system. 3. Run the test again. 4. Make sure that the DSA code and IMM firmware are at the latest level. 5. Make sure that the IMM firmware is at the latest level. The installed firmware level is shown in the DSA event log in the Firmware/VPD section for this component. For more information, see "Updating the firmware" on page 455. 6. Run the test again. 7. If the failure remains, go to the IBM website for more troubleshooting information at http://www.ibm.com/support/entry/portal/docdisplay?Indocid=SERV-CALL.
166-821-xxx	IMM	IMM I2C Test	Aborted	IMM I2C test aborted: a command response could not be provided; IMM initialization is in progress.	<ul style="list-style-type: none"> 1. Turn off the system and disconnect it from the power source. You must disconnect the system from ac power to reset the IMM. 2. After 45 seconds, reconnect the system to the power source and turn on the system. 3. Run the test again. 4. Make sure that the DSA code is at the latest level. For the latest level of DSA code, go to http://www.ibm.com/support/entry/portal/docdisplay?Indocid=SERV-DSA. 5. Make sure that the IMM firmware is at the latest level. The installed firmware level is shown in the DSA event log in the Firmware/VPD section for this component. For more information, see "Updating the firmware" on page 455. 6. Run the test again. 7. If the failure remains, go to the IBM website for more troubleshooting information at http://www.ibm.com/support/entry/portal/docdisplay?Indocid=SERV-CALL.

Table 9. DSA Preboot messages (continued)

Message number	Component	Test	State	Description	Action
166-822-xxx	IMM	IMM I2C Test	Aborted	IMM I2C test aborted: the destination is unavailable.	<ul style="list-style-type: none"> 1. Turn off the system and disconnect it from the power source. You must disconnect the system from ac power to reset the IMM. 2. After 45 seconds, reconnect the system to the power source and turn on the system. 3. Run the test again. 4. Make sure that the DSA code is at the latest level. For the latest level of DSA code, go to http://www.ibm.com/support/entry/portal/docdisplay?Indocid=SERV-DSA. 5. Make sure that the IMM firmware is at the latest level. The installed firmware level is shown in the DSA event log in the Firmware/VPD section for this component. For more information, see "Updating the firmware" on page 455. 6. Run the test again. 7. If the failure remains, go to the IBM website for more troubleshooting information at http://www.ibm.com/support/entry/portal/docdisplay?Indocid=SERV-CALL.
166-823-xxx	IMM	IMM I2C Test	Aborted	IMM I2C test aborted: cannot execute the command; insufficient privilege level.	<ul style="list-style-type: none"> 1. Turn off the system and disconnect it from the power source. You must disconnect the system from ac power to reset the IMM. 2. After 45 seconds, reconnect the system to the power source and turn on the system. 3. Run the test again. 4. Make sure that the DSA code is at the latest level. For the latest level of DSA code, go to http://www.ibm.com/support/entry/portal/docdisplay?Indocid=SERV-DSA. 5. Make sure that the IMM firmware is at the latest level. The installed firmware level is shown in the DSA event log in the Firmware/VPD section for this component. For more information, see "Updating the firmware" on page 455. 6. Run the test again. 7. If the failure remains, go to the IBM website for more troubleshooting information at http://www.ibm.com/support/entry/portal/docdisplay?Indocid=SERV-CALL.

Table 9. DSA Preboot messages (continued)

Message number	Component	Test	State	Description	Action
166-824-xxx	IMM	IMM I2C Test	Aborted	IMM I2C test canceled: cannot execute the command.	<ul style="list-style-type: none"> 1. Turn off the system and disconnect it from the power source. You must disconnect the system from ac power to reset the IMM. 2. After 45 seconds, reconnect the system to the power source and turn on the system. 3. Run the test again. 4. Make sure that the DSA code is at the latest level. For the latest level of DSA code, go to http://www.ibm.com/support/entry/portal/docdisplay?Indocid=SERV-DSA. 5. Make sure that the IMM firmware is at the latest level. The installed firmware level is shown in the DSA event log in the Firmware/VPD section for this component. For more information, see "Updating the firmware" on page 455. 6. Run the test again. 7. If the failure remains, go to the IBM website for more troubleshooting information at http://www.ibm.com/support/entry/portal/docdisplay?Indocid=SERV-CALL.
166-901-xxx	IMM	IMM I2C Test	Failed	The IMM indicates a failure in the H8 bus (Bus 0)	<ul style="list-style-type: none"> 1. Turn off the system and disconnect it from the power source. You must disconnect the system from ac power to reset the IMM. 2. After 45 seconds, reconnect the system to the power source and turn on the system. 3. Run the test again. 4. Make sure that the DSA code is at the latest level. For the latest level of DSA code, go to http://www.ibm.com/support/entry/portal/docdisplay?Indocid=SERV-DSA. 5. Make sure that the IMM firmware is at the latest level. The installed firmware level is shown in the DSA event log in the Firmware/VPD section for this component. For more information, see "Updating the firmware" on page 455. 6. Run the test again. 7. If the failure remains, go to the IBM website for more troubleshooting information at http://www.ibm.com/support/entry/portal/docdisplay?Indocid=SERV-CALL.

Table 9. DSA Preboot messages (continued)

<ul style="list-style-type: none"> • Follow the suggested actions in the order in which they are listed in the Action column until the problem is solved. • See Chapter 4, "Parts listing, IBM System x3550 M3 Type 4254 and 7944," on page 333 to determine which components are customer replaceable units (CRU) and which components are field replaceable units (FRU). • If an action step is preceded by "(Trained service technician only)", that step must be performed only by a Trained service technician. • Go to the IBM support website at http://www.ibm.com/supportportal/ to check for technical information, hints, tips, and new device drivers or to submit a request for information. 					
Message number	Component	Test	State	Description	Action
166-902-xxx	IMM	IMM I2C Test	Failed	The IMM indicates a failure in the light path bus (Bus 1).	<ol style="list-style-type: none"> 1. Turn off the system and disconnect it from the power source. You must disconnect the system from ac power to reset the IMM. 2. After 45 seconds, reconnect the system to the power source and turn on the system. 3. Run the test again. 4. Make sure that the DSA code is at the latest level. For the latest level of DSA code, go to http://www.ibm.com/support/entry/portal/docdisplay?Indocid=SERV-DSA. 5. Make sure that the IMM firmware is at the latest level. The installed firmware level is shown in the DSA event log in the Firmware/VPD section for this component. For more information, see "Updating the firmware" on page 455. 6. Run the test again. 7. Turn off the system and disconnect it from the power source. 8. Reseat the light path diagnostics panel. 9. Reconnect the system to the power source and turn on the system. 10. Run the test again. 11. Turn off the system and disconnect it from the power source. 12. (Trained service technician only) Reseat the system board. 13. Reconnect the system to the power source and turn on the system. 14. Run the test again. 15. If the failure remains, go to the IBM website for more troubleshooting information at http://www.ibm.com/support/entry/portal/docdisplay?Indocid=SERV-CALL.

Table 9. DSA Preboot messages (continued)

Message number	Component	Test	State	Description	Action
166-903-xxx	IMM	IMM I2C Test	Failed	The IMM indicates a failure in the DIMM bus (Bus 2).	<ul style="list-style-type: none"> 1. Turn off the system and disconnect it from the power source. You must disconnect the system from ac power to reset the IMM. 2. After 45 seconds, reconnect the system to the power source and turn on the system. 3. Run the test again. 4. Make sure that the DSA code is at the latest level. For the latest level of DSA code, go to http://www.ibm.com/support/entry/portal/docdisplay?lnocid=SERV-DSA. 5. Make sure that the IMM firmware is at the latest level. The installed firmware level is shown in the DSA event log in the Firmware/VPD section for this component. For more information, see "Updating the firmware" on page 455. 6. Run the test again. 7. Disconnect the system from the power source. 8. Replace the DIMMs one at a time, and run the test again after replacing each DIMM. 9. Reconnect the system to the power source and turn on the system. 10. Run the test again. 11. Turn off the system and disconnect it from the power source. 12. Reseat all of the DIMMs. 13. Reconnect the system to the power source and turn on the system. 14. Run the test again. 15. Turn off the system and disconnect it from the power source. 16. (Trained service technician only) Reseat the system board. 17. Reconnect the system to the power source and turn on the system. 18. Run the test again. 19. If the failure remains, go to the IBM website for more troubleshooting information at http://www.ibm.com/support/entry/portal/docdisplay?lnocid=SERV-CALL.

Table 9. DSA Preboot messages (continued)

<ul style="list-style-type: none"> • Follow the suggested actions in the order in which they are listed in the Action column until the problem is solved. • See Chapter 4, "Parts listing, IBM System x3550 M3 Type 4254 and 7944," on page 333 to determine which components are customer replaceable units (CRU) and which components are field replaceable units (FRU). • If an action step is preceded by "(Trained service technician only)", that step must be performed only by a Trained service technician. • Go to the IBM support website at http://www.ibm.com/supportportal/ to check for technical information, hints, tips, and new device drivers or to submit a request for information. 					
Message number	Component	Test	State	Description	Action
166-904-xxx	IMM	IMM I2C Test	Failed	The IMM indicates a failure in the power supply bus (Bus 3).	<ol style="list-style-type: none"> 1. Turn off the system and disconnect it from the power source. You must disconnect the system from ac power to reset the IMM. 2. After 45 seconds, reconnect the system to the power source and turn on the system. 3. Run the test again. 4. Make sure that the DSA code is at the latest level. For the latest level of DSA code, go to http://www.ibm.com/support/entry/portal/docdisplay?lnodocid=SERV-DSA. 5. Make sure that the IMM firmware is at the latest level. The installed firmware level is shown in the DSA event log in the Firmware/VPD section for this component. For more information, see "Updating the firmware" on page 455. 6. Run the test again. 7. Reseat the power supply. 8. Run the test again. 9. Turn off the system and disconnect it from the power source. 10. (Trained service technician only) Reseat the system board. 11. Reconnect the system to the power source and turn on the system. 12. Run the test again. 13. If the failure remains, go to the IBM website for more troubleshooting information at http://www.ibm.com/support/entry/portal/docdisplay?lnodocid=SERV-CALL.

Table 9. DSA Preboot messages (continued)

Message number	Component	Test	State	Description	Action
166-905-xxx	IMM	IMM I2C Test	Failed	The IMM indicates a failure in the HDD bus (Bus 4).	<p>Note: Ignore the error if the hard disk drive backplane is not installed.</p> <ol style="list-style-type: none"> 1. Turn off the system and disconnect it from the power source. You must disconnect the system from ac power to reset the IMM. 2. After 45 seconds, reconnect the system to the power source and turn on the system. 3. Run the test again. 4. Make sure that the DSA code is at the latest level. For the latest level of DSA code, go to http://www.ibm.com/support/entry/portal/docdisplay?lnocid=SERV-DSA. 5. Make sure that the IMM firmware is at the latest level. The installed firmware level is shown in the DSA event log in the Firmware/VPD section for this component. For more information, see "Updating the firmware" on page 455. 6. Run the test again. 7. Turn off the system and disconnect it from the power source. 8. Reseat the hard disk drive backplane. 9. Reconnect the system to the power source and turn on the system. 10. Run the test again. 11. Turn off the system and disconnect it from the power source. 12. (Trained service technician only) Reseat the system board. 13. Reconnect the system to the power source and turn on the system. 14. Run the test again. 15. If the failure remains, go to the IBM website for more troubleshooting information at http://www.ibm.com/support/entry/portal/docdisplay?lnocid=SERV-CALL.

Table 9. DSA Preboot messages (continued)

Message number	Component	Test	State	Description	Action
<ul style="list-style-type: none"> Follow the suggested actions in the order in which they are listed in the Action column until the problem is solved. See Chapter 4, "Parts listing, IBM System x3550 M3 Type 4254 and 7944," on page 333 to determine which components are customer replaceable units (CRU) and which components are field replaceable units (FRU). If an action step is preceded by "(Trained service technician only)", that step must be performed only by a Trained service technician. Go to the IBM support website at http://www.ibm.com/supportportal/ to check for technical information, hints, tips, and new device drivers or to submit a request for information. 					
166-906-xxx	IMM	IMM I2C Test	Failed	The IMM indicates a failure in the memory configuration bus (Bus 5).	<ol style="list-style-type: none"> Turn off the system and disconnect it from the power source. You must disconnect the system from ac power to reset the IMM. After 45 seconds, reconnect the system to the power source and turn on the system. Run the test again. Make sure that the DSA code is at the latest level. For the latest level of DSA code, go to http://www.ibm.com/support/entry/portal/docdisplay?Indocid=SERV-DSA. Make sure that the IMM firmware is at the latest level. The installed firmware level is shown in the DSA event log in the Firmware/VPD section for this component. For more information, see "Updating the firmware" on page 455. Run the test again. Turn off the system and disconnect it from the power source. (Trained service technician only) Reseat the system board. Reconnect the system to the power source and turn on the system. Run the test again. If the failure remains, go to the IBM website for more troubleshooting information at http://www.ibm.com/support/entry/portal/docdisplay?Indocid=SERV-CALL.
201-801-xxx	Memory	Memory Test	Aborted	Test canceled: the system UEFI programmed the memory controller with an invalid CBAR address	<ol style="list-style-type: none"> Turn off and restart the system. Run the test again. Make sure that the server firmware is at the latest level. The installed firmware level is shown in the DSA event log in the Firmware/VPD section for this component. For more information, see "Updating the firmware" on page 455. Run the test again. If the failure remains, go to the IBM website for more troubleshooting information at http://www.ibm.com/support/entry/portal/docdisplay?Indocid=SERV-CALL.

Table 9. DSA Preboot messages (continued)

Message number	Component	Test	State	Description	Action
201-802-xxx	Memory	Memory Test	Aborted	Test canceled: the end address in the E820 function is less than 16 MB.	<ol style="list-style-type: none"> 1. Turn off and restart the system. 2. Run the test again. 3. Make sure that all DIMMs are enabled in the Setup utility. 4. Make sure that the server firmware is at the latest level. The installed firmware level is shown in the DSA event log in the Firmware/VPD section for this component. For more information, see "Updating the firmware" on page 455. 5. Run the test again. 6. If the failure remains, go to the IBM website for more troubleshooting information at http://www.ibm.com/support/entry/portal/docdisplay?Indocid=SERV-CALL.
201-803-xxx	Memory	Memory Test	Aborted	Test canceled: could not enable the processor cache.	<ol style="list-style-type: none"> 1. Turn off and restart the system. 2. Run the test again. 3. Make sure that the server firmware is at the latest level. The installed firmware level is shown in the DSA event log in the Firmware/VPD section for this component. For more information, see "Updating the firmware" on page 455. 4. Run the test again. 5. If the failure remains, go to the IBM website for more troubleshooting information at http://www.ibm.com/support/entry/portal/docdisplay?Indocid=SERV-CALL.
201-804-xxx	Memory	Memory Test	Aborted	Test canceled: the memory controller buffer request failed.	<ol style="list-style-type: none"> 1. Turn off and restart the system. 2. Run the test again. 3. Make sure that the server firmware is at the latest level. The installed firmware level is shown in the DSA event log in the Firmware/VPD section for this component. For more information, see "Updating the firmware" on page 455. 4. Run the test again. 5. If the failure remains, go to the IBM website for more troubleshooting information at http://www.ibm.com/support/entry/portal/docdisplay?Indocid=SERV-CALL.

Table 9. DSA Preboot messages (continued)

- Follow the suggested actions in the order in which they are listed in the Action column until the problem is solved.
- See Chapter 4, "Parts listing, IBM System x3550 M3 Type 4254 and 7944," on page 333 to determine which components are customer replaceable units (CRU) and which components are field replaceable units (FRU).
- If an action step is preceded by "(Trained service technician only)", that step must be performed only by a Trained service technician.
- Go to the IBM support website at <http://www.ibm.com/supportportal/> to check for technical information, hints, tips, and new device drivers or to submit a request for information.

Message number	Component	Test	State	Description	Action
201-805-xxx	Memory	Memory Test	Aborted	Test canceled: the memory controller display/alter write operation was not completed.	<ol style="list-style-type: none"> 1. Turn off and restart the system. 2. Run the test again. 3. Make sure that the server firmware is at the latest level. The installed firmware level is shown in the DSA event log in the Firmware/VPD section for this component. For more information, see "Updating the firmware" on page 455. 4. Run the test again. 5. If the failure remains, go to the IBM website for more troubleshooting information at http://www.ibm.com/support/entry/portal/docdisplay?lnocid=SERV-CALL.
201-806-xxx	Memory	Memory Test	Aborted	Test canceled: the memory controller fast scrub operation was not completed.	<ol style="list-style-type: none"> 1. Turn off and restart the system. 2. Run the test again. 3. Make sure that the server firmware is at the latest level. The installed firmware level is shown in the DSA event log in the Firmware/VPD section for this component. For more information, see "Updating the firmware" on page 455. 4. Run the test again. 5. If the failure remains, go to the IBM website for more troubleshooting information at http://www.ibm.com/support/entry/portal/docdisplay?lnocid=SERV-CALL.
201-807-xxx	Memory	Memory Test	Aborted	Test canceled: the memory controller buffer free request failed.	<ol style="list-style-type: none"> 1. Turn off and restart the system. 2. Run the test again. 3. Make sure that the server firmware is at the latest level. The installed firmware level is shown in the DSA event log in the Firmware/VPD section for this component. For more information, see "Updating the firmware" on page 455. 4. Run the test again. 5. If the failure remains, go to the IBM website for more troubleshooting information at http://www.ibm.com/support/entry/portal/docdisplay?lnocid=SERV-CALL.

Table 9. DSA Preboot messages (continued)

Message number	Component	Test	State	Description	Action
<ul style="list-style-type: none"> Follow the suggested actions in the order in which they are listed in the Action column until the problem is solved. See Chapter 4, "Parts listing, IBM System x3550 M3 Type 4254 and 7944," on page 333 to determine which components are customer replaceable units (CRU) and which components are field replaceable units (FRU). If an action step is preceded by "(Trained service technician only)", that step must be performed only by a Trained service technician. Go to the IBM support website at http://www.ibm.com/supportportal/ to check for technical information, hints, tips, and new device drivers or to submit a request for information. 					
201-808-xxx	Memory	Memory Test	Aborted	Test canceled: memory controller display/alter buffer execute error.	<ol style="list-style-type: none"> Turn off and restart the system. Run the test again. Make sure that the server firmware is at the latest level. The installed firmware level is shown in the DSA event log in the Firmware/VPD section for this component. For more information, see "Updating the firmware" on page 455. Run the test again. If the failure remains, go to the IBM website for more troubleshooting information at http://www.ibm.com/support/entry/portal/docdisplay?lnocid=SERV-CALL.
201-809-xxx	Memory	Memory Test	Aborted	Test canceled program error: operation running fast scrub.	<ol style="list-style-type: none"> Turn off and restart the system. Run the test again. Make sure that the DSA code is at the latest level. For the latest level of DSA code, go to http://www.ibm.com/support/entry/portal/docdisplay?lnocid=SERV-DSA. Make sure that the server firmware is at the latest level. The installed firmware level is shown in the DSA event log in the Firmware/VPD section for this component. For more information, see "Updating the firmware" on page 455. Run the test again. If the failure remains, go to the IBM website for more troubleshooting information at http://www.ibm.com/support/entry/portal/docdisplay?lnocid=SERV-CALL.
201-810-xxx	Memory	Memory Test	Aborted	Test stopped: unknown error code xxx received in COMMONEXIT procedure.	<ol style="list-style-type: none"> Turn off and restart the system. Run the test again. Make sure that the DSA code is at the latest level. For the latest level of DSA code, go to http://www.ibm.com/support/entry/portal/docdisplay?lnocid=SERV-DSA. Make sure that the server firmware is at the latest level. The installed firmware level is shown in the DSA event log in the Firmware/VPD section for this component. For more information, see "Updating the firmware" on page 455. Run the test again. If the failure remains, go to the IBM website for more troubleshooting information at http://www.ibm.com/support/entry/portal/docdisplay?lnocid=SERV-CALL.

Table 9. DSA Preboot messages (continued)

- Follow the suggested actions in the order in which they are listed in the Action column until the problem is solved.
- See Chapter 4, “Parts listing, IBM System x3550 M3 Type 4254 and 7944,” on page 333 to determine which components are customer replaceable units (CRU) and which components are field replaceable units (FRU).
- If an action step is preceded by “(Trained service technician only)”, that step must be performed only by a Trained service technician.
- Go to the IBM support website at <http://www.ibm.com/supportportal/> to check for technical information, hints, tips, and new device drivers or to submit a request for information.

Message number	Component	Test	State	Description	Action
201-901-xxx	Memory	Memory Test	Failed	Test failure: single-bit error, failing DIMM z.	<ol style="list-style-type: none"> 1. Turn off the system and disconnect it from the power source. 2. Reseat DIMM z. 3. Reconnect the system to power and turn on the system. 4. Make sure that the DSA code is at the latest level. For the latest level of DSA code, go to http://www.ibm.com/support/entry/portal/docdisplay?Indocid=SERV-DSA. 5. Make sure that the server firmware is at the latest level. The installed firmware level is shown in the DSA event log in the Firmware/VPD section for this component. For more information, see “Updating the firmware” on page 455. 6. Run the test again. 7. Replace the failing DIMMs. 8. Re-enable all memory in the Setup utility (see “Using the Setup utility” on page 460). 9. Run the test again. 10. Replace the failing DIMM. 11. Re-enable all memory in the Setup utility (see “Using the Setup utility” on page 460). 12. Run the test again. 13. If the failure remains, go to the IBM website for more troubleshooting information at http://www.ibm.com/support/entry/portal/docdisplay?Indocid=SERV-CALL.
202-801-xxx	Memory	Memory Stress Test	Aborted	Internal program error.	<ol style="list-style-type: none"> 1. Turn off and restart the system. 2. Make sure that the DSA code is at the latest level. For the latest level of DSA code, go to http://www.ibm.com/support/entry/portal/docdisplay?Indocid=SERV-DSA. 3. Make sure that the server firmware is at the latest level. The installed firmware level is shown in the DSA event log in the Firmware/VPD section for this component. For more information, see “Updating the firmware” on page 455. 4. Run the test again. 5. Turn off and restart the system if necessary to recover from a hung state. 6. Run the memory diagnostics to identify the specific failing DIMM. 7. If the failure remains, go to the IBM website for more troubleshooting information at http://www.ibm.com/support/entry/portal/docdisplay?Indocid=SERV-CALL.

Table 9. DSA Preboot messages (continued)

Message number	Component	Test	State	Description	Action
202-802-xxx	Memory	Memory Stress Test	Failed	General error: memory size is insufficient to run the test.	<ul style="list-style-type: none"> 1. Make sure that all memory is enabled by checking the Available System Memory in the Resource Utilization section of the DSA event log. If necessary, enable all memory in the Setup utility (see "Using the Setup utility" on page 460). 2. Make sure that the DSA code is at the latest level. For the latest level of DSA code, go to http://www.ibm.com/support/entry/portal/docdisplay?Indocid=SERV-DSA. 3. Run the test again. 4. Run the standard memory test to validate all memory. 5. If the failure remains, go to the IBM website for more troubleshooting information at http://www.ibm.com/support/entry/portal/docdisplay?Indocid=SERV-CALL.
202-901-xxx	Memory	Memory Stress Test	Failed	Test failure.	<ul style="list-style-type: none"> 1. Run the standard memory test to validate all memory. 2. Make sure that the DSA code is at the latest level. For the latest level of DSA code, go to http://www.ibm.com/support/entry/portal/docdisplay?Indocid=SERV-DSA. 3. Turn off the system and disconnect it from power. 4. Reseat the DIMMs. 5. Reconnect the system to power and turn on the system. 6. Run the test again. 7. Run the standard memory test to validate all memory. 8. If the failure remains, go to the IBM website for more troubleshooting information at http://www.ibm.com/support/entry/portal/docdisplay?Indocid=SERV-CALL.

Table 9. DSA Preboot messages (continued)

- Follow the suggested actions in the order in which they are listed in the Action column until the problem is solved.
- See Chapter 4, "Parts listing, IBM System x3550 M3 Type 4254 and 7944," on page 333 to determine which components are customer replaceable units (CRU) and which components are field replaceable units (FRU).
- If an action step is preceded by "(Trained service technician only)", that step must be performed only by a Trained service technician.
- Go to the IBM support website at <http://www.ibm.com/supportportal/> to check for technical information, hints, tips, and new device drivers or to submit a request for information.

Message number	Component	Test	State	Description	Action
215-801-xxx	Optical Drive	<ul style="list-style-type: none"> • Verify Media Installed • Read/Write Test • Self-Test <p>Messages and actions apply to all three tests.</p>	Aborted	Unable to communicate with the device driver.	<ol style="list-style-type: none"> 1. Make sure that the DSA code is at the latest level. For the latest level of DSA code, go to http://www.ibm.com/support/entry/portal/docdisplay?Indocid=SERV-DSA. 2. Run the test again. 3. Check the drive cabling at both ends for loose or broken connections or damage to the cable. Replace the cable if it is damaged. 4. Run the test again. 5. For additional troubleshooting information, go to http://www.ibm.com/support/entry/portal/docdisplay?Indocid=MIGR-41559. 6. Run the test again. 7. Make sure that the system firmware is at the latest level. The installed firmware level is shown in the DSA event log in the Firmware/VPD section for this component. For more information, see "Updating the firmware" on page 455. 8. Run the test again. 9. Replace the DVD drive. 10. If the failure remains, go to the IBM website for more troubleshooting information at http://www.ibm.com/support/entry/portal/docdisplay?Indocid=SERV-CALL.

Table 9. DSA Preboot messages (continued)

Message number	Component	Test	State	Description	Action
215-802-xxx	Optical Drive	<ul style="list-style-type: none"> • Verify Media Installed • Read/Write Test • Self-Test <p>Messages and actions apply to all three tests.</p>	Aborted	The media tray is open.	<ol style="list-style-type: none"> 1. Close the media tray and wait 15 seconds. 2. Run the test again. 3. Insert a new CD/DVD into the drive and wait for 15 seconds for the media to be recognized. 4. Run the test again. 5. Check the drive cabling at both ends for loose or broken connections or damage to the cable. Replace the cable if it is damaged. 6. Run the test again. 7. Make sure that the DSA code is at the latest level. For the latest level of DSA code, go to http://www.ibm.com/support/entry/portal/docdisplay?Indocid=SERV-DSA. 8. Run the test again. 9. For additional troubleshooting information, go to http://www.ibm.com/support/entry/portal/docdisplay?Indocid=MIGR-41559. 10. Run the test again. 11. Replace the CD/DVD drive. 12. If the failure remains, go to the IBM website for more troubleshooting information at http://www.ibm.com/support/entry/portal/docdisplay?Indocid=SERV-CALL.
215-803-xxx	Optical Drive	<ul style="list-style-type: none"> • Verify Media Installed • Read/Write Test • Self-Test <p>Messages and actions apply to all three tests.</p>	Failed	The disc might be in use by the system.	<ol style="list-style-type: none"> 1. Wait for the system activity to stop. 2. Run the test again 3. Turn off and restart the system. 4. Run the test again. 5. Replace the DVD drive. 6. If the failure remains, go to the IBM website for more troubleshooting information at http://www.ibm.com/support/entry/portal/docdisplay?Indocid=SERV-CALL.

Table 9. DSA Preboot messages (continued)

<ul style="list-style-type: none"> Follow the suggested actions in the order in which they are listed in the Action column until the problem is solved. See Chapter 4, "Parts listing, IBM System x3550 M3 Type 4254 and 7944," on page 333 to determine which components are customer replaceable units (CRU) and which components are field replaceable units (FRU). If an action step is preceded by "(Trained service technician only)", that step must be performed only by a Trained service technician. Go to the IBM support website at http://www.ibm.com/supportportal/ to check for technical information, hints, tips, and new device drivers or to submit a request for information. 					
Message number	Component	Test	State	Description	Action
215-901-xxx	Optical Drive	<ul style="list-style-type: none"> Verify Media Installed Read/Write Test Self-Test <p>Messages and actions apply to all three tests.</p>	Aborted	Drive media is not detected.	<ol style="list-style-type: none"> Insert a CD/DVD into the DVD drive or try a new media, and wait for 15 seconds. Run the test again. Check the drive cabling at both ends for loose or broken connections or damage to the cable. Replace the cable if it is damaged. Run the test again. For additional troubleshooting information, go to http://www.ibm.com/support/entry/portal/docdisplay?Indocid=MIGR-41559. Run the test again. Replace the DVD drive. If the failure remains, go to the IBM website for more troubleshooting information at http://www.ibm.com/support/entry/portal/docdisplay?Indocid=SERV-CALL.
215-902-xxx	Optical Drive	<ul style="list-style-type: none"> Verify Media Installed Read/Write Test Self-Test <p>Messages and actions apply to all three tests.</p>	Failed	Read miscompare.	<ol style="list-style-type: none"> Insert a CD/DVD into the DVD drive or try a new media, and wait for 15 seconds. Run the test again. Check the drive cabling at both ends for loose or broken connections or damage to the cable. Replace the cable if it is damaged. Run the test again. For additional troubleshooting information, go to http://www.ibm.com/support/entry/portal/docdisplay?Indocid=MIGR-41559. Run the test again. Replace the DVD drive. If the failure remains, go to the IBM website for more troubleshooting information at http://www.ibm.com/support/entry/portal/docdisplay?Indocid=SERV-CALL.

Table 9. DSA Preboot messages (continued)

Message number	Component	Test	State	Description	Action
215-903-xxx	Optical Drive	<ul style="list-style-type: none"> • Verify Media Installed • Read/Write Test • Self-Test <p>Messages and actions apply to all three tests.</p>	Aborted	Could not access the drive.	<ol style="list-style-type: none"> 1. Insert a CD/DVD into the DVD drive or try a new media, and wait for 15 seconds. 2. Run the test again. 3. Check the drive cabling at both ends for loose or broken connections or damage to the cable. Replace the cable if it is damaged. 4. Run the test again. 5. Make sure that the DSA code is at the latest level. For the latest level of DSA code, go to http://www.ibm.com/support/entry/portal/docdisplay?Indocid=SERV-DSA. 6. Run the test again. 7. For additional troubleshooting information, go to http://www.ibm.com/support/entry/portal/docdisplay?Indocid=MIGR-41559. 8. Run the test again. 9. Replace the DVD drive. 10. If the failure remains, go to the IBM website for more troubleshooting information at http://www.ibm.com/support/entry/portal/docdisplay?Indocid=SERV-CALL.
215-904-xxx	Optical Drive	<ul style="list-style-type: none"> • Verify Media Installed • Read/Write Test • Self-Test <p>Messages and actions apply to all three tests.</p>	Failed	A read error occurred.	<ol style="list-style-type: none"> 1. Insert a CD/DVD into the DVD drive or try a new media, and wait for 15 seconds. 2. Run the test again. 3. Check the drive cabling at both ends for loose or broken connections or damage to the cable. Replace the cable if it is damaged. 4. Run the test again. 5. For additional troubleshooting information, go to http://www.ibm.com/support/entry/portal/docdisplay?Indocid=MIGR-41559. 6. Run the test again. 7. Replace the DVD drive. 8. If the failure remains, go to the IBM website for more troubleshooting information at http://www.ibm.com/support/entry/portal/docdisplay?Indocid=SERV-CALL.

Table 9. DSA Preboot messages (continued)

- Follow the suggested actions in the order in which they are listed in the Action column until the problem is solved.
- See Chapter 4, "Parts listing, IBM System x3550 M3 Type 4254 and 7944," on page 333 to determine which components are customer replaceable units (CRU) and which components are field replaceable units (FRU).
- If an action step is preceded by "(Trained service technician only)", that step must be performed only by a Trained service technician.
- Go to the IBM support website at <http://www.ibm.com/supportportal/> to check for technical information, hints, tips, and new device drivers or to submit a request for information.

Message number	Component	Test	State	Description	Action
405-901-xxx	BroadCom Ethernet Device	Test Control Registers	Failed		<ol style="list-style-type: none"> 1. Make sure that the component firmware is at the latest level. The installed firmware level is shown in the DSA event log in the Firmware/VPD section for this component. For more information, see "Updating the firmware" on page 455. 2. Run the test again. 3. Replace the component that is causing the error. If the error is caused by an adapter, replace the adapter. Check the PCI Information and Network Settings information in the DSA event log to determine the physical location of the failing component. 4. If the failure remains, go to the IBM website for more troubleshooting information at http://www.ibm.com/support/entry/portal/docdisplay?lnocid=SERV-CALL.
405-901-xxx	BroadCom Ethernet Device	Test MII Registers	Failed		<ol style="list-style-type: none"> 1. Make sure that the component firmware is at the latest level. The installed firmware level is shown in the DSA event log in the Firmware/VPD section for this component. For more information, see "Updating the firmware" on page 455. 2. Run the test again. 3. Replace the component that is causing the error. If the error is caused by an adapter, replace the adapter. Check the PCI Information and Network Settings information in the DSA event log to determine the physical location of the failing component. 4. If the failure remains, go to the IBM website for more troubleshooting information at http://www.ibm.com/support/entry/portal/docdisplay?lnocid=SERV-CALL.

Table 9. DSA Preboot messages (continued)

<ul style="list-style-type: none"> Follow the suggested actions in the order in which they are listed in the Action column until the problem is solved. See Chapter 4, "Parts listing, IBM System x3550 M3 Type 4254 and 7944," on page 333 to determine which components are customer replaceable units (CRU) and which components are field replaceable units (FRU). If an action step is preceded by "(Trained service technician only)", that step must be performed only by a Trained service technician. Go to the IBM support website at http://www.ibm.com/supportportal/ to check for technical information, hints, tips, and new device drivers or to submit a request for information. 					
Message number	Component	Test	State	Description	Action
405-902-xxx	BroadCom Ethernet Device	Test EEPROM	Failed		<ol style="list-style-type: none"> Make sure that the component firmware is at the latest level. The installed firmware level is shown in the DSA event log in the Firmware/VPD section for this component. For more information, see "Updating the firmware" on page 455. Run the test again. Replace the component that is causing the error. If the error is caused by an adapter, replace the adapter. Check the PCI Information and Network Settings information in the DSA event log to determine the physical location of the failing component. If the failure remains, go to the IBM website for more troubleshooting information at http://www.ibm.com/support/entry/portal/docdisplay?Indocid=SERV-CALL.
405-903-xxx	BroadCom Ethernet Device	Test Internal Memory	Failed		<ol style="list-style-type: none"> Make sure that the component firmware is at the latest level. The installed firmware level is shown in the DSA event log in the Firmware/VPD section for this component. For more information, see "Updating the firmware" on page 455. Run the test again. Check the interrupt assignments in the PCI Hardware section of the DSA event log. If the Ethernet device is sharing interrupts, if possible, use the Setup utility see "Using the Setup utility" on page 460 to assign a unique interrupt to the device. Replace the component that is causing the error. If the error is caused by an adapter, replace the adapter. Check the PCI Information and Network Settings information in the DSA event log to determine the physical location of the failing component. If the failure remains, go to the IBM website for more troubleshooting information at http://www.ibm.com/support/entry/portal/docdisplay?Indocid=SERV-CALL.

Table 9. DSA Preboot messages (continued)

Message number	Component	Test	State	Description	Action
405-904-xxx	BroadCom Ethernet Device	Test Interrupt	Failed		<ul style="list-style-type: none"> 1. Make sure that the component firmware is at the latest level. The installed firmware level is shown in the DSA event log in the Firmware/VPD section for this component. For more information, see "Updating the firmware" on page 455. 2. Run the test again. 3. Check the interrupt assignments in the PCI Hardware section of the DSA event log. If the Ethernet device is sharing interrupts, if possible, use the Setup utility see "Using the Setup utility" on page 460 to assign a unique interrupt to the device. 4. Replace the component that is causing the error. If the error is caused by an adapter, replace the adapter. Check the PCI Information and Network Settings information in the DSA event log to determine the physical location of the failing component. 5. If the failure remains, go to the IBM website for more troubleshooting information at http://www.ibm.com/support/entry/portal/docdisplay?lnocid=SERV-CALL.
405-905-xxx	BroadCom Ethernet Device	Test Loop back at MAC Layer	Failed		<ul style="list-style-type: none"> 1. Make sure that the component firmware is at the latest level. The installed firmware level is shown in the DSA event log in the Firmware/VPD section for this component. For more information, see "Updating the firmware" on page 455. 2. Run the test again. 3. Replace the component that is causing the error. If the error is caused by an adapter, replace the adapter. Check the PCI Information and Network Settings information in the DSA event log to determine the physical location of the failing component. 4. If the failure remains, go to the IBM website for more troubleshooting information at http://www.ibm.com/support/entry/portal/docdisplay?lnocid=SERV-CALL.

Table 9. DSA Preboot messages (continued)

Message number	Component	Test	State	Description	Action
405-906-xxx	BroadCom Ethernet Device	Test Loop back at Physical Layer	Failed		<ul style="list-style-type: none"> 1. Check the Ethernet cable for damage and make sure that the cable type and connection are correct. 2. Make sure that the component firmware is at the latest level. The installed firmware level is shown in the DSA event log in the Firmware/VPD section for this component. For more information, see "Updating the firmware" on page 455. 3. Run the test again. 4. Replace the component that is causing the error. If the error is caused by an adapter, replace the adapter. Check the PCI Information and Network Settings information in the DSA event log to determine the physical location of the failing component. 5. If the failure remains, go to the IBM website for more troubleshooting information at http://www.ibm.com/support/entry/portal/docdisplay?Indocid=SERV-CALL.
405-907-xxx	BroadCom Ethernet Device	Test LEDs	Failed		<ul style="list-style-type: none"> 1. Make sure that the component firmware is at the latest level. The installed firmware level is shown in the DSA event log in the Firmware/VPD section for this component. For more information, see "Updating the firmware" on page 455. 2. Run the test again. 3. Replace the component that is causing the error. If the error is caused by an adapter, replace the adapter. Check the PCI Information and Network Settings information in the DSA event log to determine the physical location of the failing component. 4. If the failure remains, go to the IBM website for more troubleshooting information at http://www.ibm.com/support/entry/portal/docdisplay?Indocid=SERV-CALL.

Checkout procedure

The checkout procedure is the sequence of tasks that you should follow to diagnose a problem in the server.

About the checkout procedure

Review the following information before you perform the checkout procedure for diagnosing hardware problems.

- Read the safety information that begins on “Safety” on page vii.
- The diagnostic programs provide the primary methods of testing the major components of the server, such as the system board, Ethernet controller, keyboard, mouse (pointing device), serial ports, and hard disk drives. You can also use them to test some external devices. If you are not sure whether a problem is caused by the hardware or by the software, you can use the diagnostic programs to confirm that the hardware is working correctly.
- When you run the diagnostic programs, a single problem might cause more than one error message. When this happens, correct the cause of the first error message. The other error messages usually will not occur the next time you run the diagnostic programs.

Exception: If multiple error codes or light path diagnostics LEDs indicate a microprocessor error, the error might be in the microprocessor or in the microprocessor socket. See “Microprocessor problems” on page 300 for information about diagnosing microprocessor problems.

- Before you run the diagnostic programs, you must determine whether the failing server is part of a shared hard disk drive cluster (two or more servers sharing external storage devices). If it is part of a cluster, you can run all diagnostic programs except the ones that test the storage unit (that is, a hard disk drive in the storage unit) or the storage adapter that is attached to the storage unit. The failing server might be part of a cluster if any of the following conditions is true:
 - You have identified the failing server as part of a cluster (two or more servers sharing external storage devices).
 - One or more external storage units are attached to the failing server and at least one of the attached storage units is also attached to another server or unidentifiable device.
 - One or more servers are located near the failing server.

Important: If the server is part of a shared hard disk drive cluster, run one test at a time. Do not run any suite of tests, such as “quick” or “normal” tests, because this might enable the hard disk drive diagnostic tests.

- If the server is halted and a POST error code is displayed, see “POST error codes” on page 242. If the server is halted and no error message is displayed, see “Troubleshooting tables” on page 292 and “Solving undetermined problems” on page 329.
- For information about power-supply problems, see “Solving power problems” on page 328.
- For intermittent problems, check the error log; see “Event logs” on page 27 and “Diagnostic messages” on page 257.

Performing the checkout procedure

Use this information to perform the checkout procedure.

About this task

To perform the checkout procedure, complete the following steps:

Procedure

1. Is the server part of a cluster?
 - **No:** Go to step 2.
 - **Yes:** Shut down all failing servers that are related to the cluster. Go to step 2.
2. Complete the following steps:
 - a. Check the power supply LEDs (see “Power-supply LEDs” on page 319).
 - b. Turn off the server and all external devices.
 - c. Check all internal and external devices for compatibility at <http://www.ibm.com/systems/info/x86servers/serverproven/compat/us/>.
 - d. Check all cables and power cords.
 - e. Set all display controls to the middle positions.
 - f. Turn on all external devices.
 - g. Turn on the server. If the server does not start, see “Troubleshooting tables” on page 292.
 - h. Check the system-error LED on the operator information panel. If it is lit or flashing, check the light path diagnostics LEDs (see “Light path diagnostics” on page 309).

Note: When you slide the light path diagnostics panel out of the server to check the LEDs or checkpoint codes, do not run the server continuously with light path diagnostics panel outside of the server. The panel should only be outside of the server a short time. The light path diagnostics panel must remain in the server when the server is running to ensure proper cooling.

- i. Check for the following results:
 - Successful completion of POST (see “POST” on page 242 for more information)
 - Successful completion of startup

Troubleshooting tables

Use the troubleshooting tables to find solutions to problems that have identifiable symptoms.

About this task

Use the troubleshooting tables to find solutions to problems that have identifiable symptoms.

If you cannot find a problem in these tables, see “Diagnostic messages” on page 257 for information about testing the server.

If you have just added new software or a new optional device and the server is not working, complete the following steps before you use the troubleshooting tables:

Procedure

1. Check the system-error LED on the operator information panel; if it is lit, check the light path diagnostics LEDs (see “Light path diagnostics” on page 309).
2. Remove the software or device that you just added.
3. Run the diagnostic tests to determine whether the server is running correctly.
4. Reinstall the new software or new device.

DVD drive problems

Use this information to solve DVD drive problems.

- Follow the suggested actions in the order in which they are listed in the Action column until the problem is solved.
- See Chapter 4, “Parts listing, IBM System x3550 M3 Type 4254 and 7944,” on page 333 to determine which components are customer replaceable units (CRU) and which components are field replaceable units (FRU).
- If an action step is preceded by “(Trained service technician only),” that step must be performed only by a Trained service technician.
- Go to the IBM support website at <http://www.ibm.com/supportportal/> to check for technical information, hints, tips, and new device drivers or to submit a request for information.

Symptom	Action
The optional DVD drive is not recognized.	<ol style="list-style-type: none">1. Make sure that:<ul style="list-style-type: none">• The SATA connector to which the DVD drive is attached (primary or secondary) is enabled in the Setup utility.• All cables and jumpers are installed correctly.• The correct device driver is installed for the DVD drive.2. Run the DVD drive diagnostic programs.3. Reseat the following components:<ol style="list-style-type: none">a. DVD driveb. DVD drive cable4. Replace the components listed in step 3 one at a time, in the order shown, restarting the server each time.5. (Trained service technician only) Replace the system board.

<ul style="list-style-type: none"> • Follow the suggested actions in the order in which they are listed in the Action column until the problem is solved. • See Chapter 4, “Parts listing, IBM System x3550 M3 Type 4254 and 7944,” on page 333 to determine which components are customer replaceable units (CRU) and which components are field replaceable units (FRU). • If an action step is preceded by “(Trained service technician only),” that step must be performed only by a Trained service technician. • Go to the IBM support website at http://www.ibm.com/supportportal/ to check for technical information, hints, tips, and new device drivers or to submit a request for information. 	
Symptom	Action
A CD or DVD is not working correctly.	<ol style="list-style-type: none"> 1. Clean the CD or DVD. 2. Replace the CD or DVD with new CD or DVD media. 3. Run the DVD drive diagnostic programs. 4. Reseat the DVD drive. 5. Replace the DVD drive.
The DVD drive tray is not working.	<ol style="list-style-type: none"> 1. Make sure that the server is turned on. 2. Insert the end of a straightened paper clip into the manual tray-release opening. 3. Reseat the DVD drive. 4. Replace the DVD drive.

General problems

Use this information to solve general problems.

<ul style="list-style-type: none"> • Follow the suggested actions in the order in which they are listed in the Action column until the problem is solved. • See Chapter 4, “Parts listing, IBM System x3550 M3 Type 4254 and 7944,” on page 333 to determine which components are customer replaceable units (CRU) and which components are field replaceable units (FRU). • If an action step is preceded by “(Trained service technician only),” that step must be performed only by a Trained service technician. • Go to the IBM support website at http://www.ibm.com/supportportal/ to check for technical information, hints, tips, and new device drivers or to submit a request for information. 	
Symptom	Action
A cover latch is broken, an LED is not working, or a similar problem has occurred.	If the part is a CRU, replace it. If the part is a FRU, the part must be replaced by a trained service technician.
The server is hung while the screen is on. Cannot start the Setup utility by pressing F1.	<ol style="list-style-type: none"> 1. See “Nx boot failure” on page 327 for more information. 2. See “Recovering the server firmware” on page 323 for more information.

Hard disk drive problems

Use this information to solve hard disk drive problems.

<ul style="list-style-type: none"> Follow the suggested actions in the order in which they are listed in the Action column until the problem is solved. See Chapter 4, "Parts listing, IBM System x3550 M3 Type 4254 and 7944," on page 333 to determine which components are customer replaceable units (CRU) and which components are field replaceable units (FRU). If an action step is preceded by "(Trained service technician only)," that step must be performed only by a Trained service technician. Go to the IBM support website at http://www.ibm.com/supportportal/ to check for technical information, hints, tips, and new device drivers or to submit a request for information. 	
Symptom	Action
A hard disk drive has failed, and the associated amber hard disk drive status LED is lit.	Replace the failed hard disk drive.
A newly installed hard disk drive is not recognized.	<ol style="list-style-type: none"> Make sure that the installed hard disk drive or RAID adapter is supported. For a list of supported optional devices, see http://www.ibm.com/systems/info/x86servers/serverproven/compat/us/. Observe the associated amber hard disk drive status LED. If the LED is lit, it indicates a drive fault. If the LED is lit, remove the drive from the bay, wait 45 seconds, and reinsert the drive, making sure that the drive assembly connects to the hard disk drive backplane. Observe the associated green hard disk drive activity LED and the amber status LED: <ul style="list-style-type: none"> If the green activity LED is flashing and the amber status LED is not lit, the drive is recognized by the controller and is working correctly. Run the DSA diagnostics program to determine whether the drive is detected. If the green activity LED is flashing and the amber status LED is flashing slowly, the drive is recognized by the controller and is rebuilding. If neither LED is lit or flashing, check the hard disk drive backplane (go to step 5). If the green activity LED is flashing and the amber status LED is lit, replace the drive. If the activity of the LEDs remains the same, go to step 5. If the activity of the LEDs changes, return to step 2. Make sure that the hard disk drive backplane is correctly seated. When it is correctly seated, the drive assemblies correctly connect to the backplane without bowing or causing movement of the backplane. Reseat the backplane power cable and repeat steps 2 through 4. Reseat the backplane signal cable and repeat steps 2 through 4. Suspect the backplane signal cable or the backplane: <ul style="list-style-type: none"> If the server has eight hot-swap bays: <ol style="list-style-type: none"> Replace the affected backplane signal cable. Replace the affected backplane. See "Problem determination tips" on page 330.
Multiple hard disk drives fail.	<p>Make sure that the hard disk drive, SAS/SATA adapter, and server device drivers and firmware are at the latest level.</p> <p>Important: Some cluster solutions require specific code levels or coordinated code updates. If the device is part of a cluster solution, verify that the latest level of code is supported for the cluster solution before you update the code.</p>

<ul style="list-style-type: none"> • Follow the suggested actions in the order in which they are listed in the Action column until the problem is solved. • See Chapter 4, “Parts listing, IBM System x3550 M3 Type 4254 and 7944,” on page 333 to determine which components are customer replaceable units (CRU) and which components are field replaceable units (FRU). • If an action step is preceded by “(Trained service technician only),” that step must be performed only by a Trained service technician. • Go to the IBM support website at http://www.ibm.com/supportportal/ to check for technical information, hints, tips, and new device drivers or to submit a request for information. 	
Symptom	Action
Multiple hard disk drives are offline.	<ol style="list-style-type: none"> 1. Review the storage subsystem logs for indications of problems within the storage subsystem, such as backplane or cable problems. 2. See “Problem determination tips” on page 330.
A replacement hard disk drive does not rebuild.	<ol style="list-style-type: none"> 1. Make sure that the hard disk drive is recognized by the adapter (the green hard disk drive activity LED is flashing). 2. Review the SAS/SATA adapter documentation to determine the correct configuration parameters and settings.
A green hard disk drive activity LED does not accurately represent the actual state of the associated drive.	<p>If the green hard disk drive activity LED does not flash when the drive is in use, run the DSA Preboot diagnostic programs to collect error logs (see “Running the diagnostic programs” on page 255).</p> <ul style="list-style-type: none"> • If there is a hard disk drive error log, replace the affected hard disk drive. • If there is no disk drive error log error log, replace the affected backplane.
An amber hard disk drive status LED does not accurately represent the actual state of the associated drive.	<ol style="list-style-type: none"> 1. If the amber hard disk drive LED and the RAID adapter software do not indicate the same status for the drive, complete the following steps: <ol style="list-style-type: none"> a. Turn off the server. b. Reseat the SAS/SATA adapter. c. Reseat the backplane signal cable and backplane power cable. d. Reseat the hard disk drive. e. Turn on the server and observe the activity of the hard disk drive LEDs. 2. See “Problem determination tips” on page 330.

Hypervisor problems

Use this information to solve hypervisor problems.

<ul style="list-style-type: none"> • Follow the suggested actions in the order in which they are listed in the Action column until the problem is solved. • See Chapter 4, “Parts listing, IBM System x3550 M3 Type 4254 and 7944,” on page 333 to determine which components are customer replaceable units (CRU) and which components are field replaceable units (FRU). • If an action step is preceded by “(Trained service technician only),” that step must be performed only by a Trained service technician. • Go to the IBM support website at http://www.ibm.com/supportportal/ to check for technical information, hints, tips, and new device drivers or to submit a request for information. 	
Symptom	Action
If an optional embedded hypervisor flash device is not listed in the expected boot order, does not appear in the list of boot devices, or a similar problem has occurred.	<ol style="list-style-type: none"> 1. Make sure that the optional embedded hypervisor flash device is selected on the boot manager (<F12> Select Boot Device) at startup. 2. Make sure that the embedded hypervisor flash device is seated in the connector correctly. 3. See the documentation that comes with the optional embedded hypervisor flash device for setup and configuration information. 4. Make sure that other software works on the server.

Intermittent problems

Use this information to solve intermittent problems.

- Follow the suggested actions in the order in which they are listed in the Action column until the problem is solved.
- See Chapter 4, “Parts listing, IBM System x3550 M3 Type 4254 and 7944,” on page 333 to determine which components are customer replaceable units (CRU) and which components are field replaceable units (FRU).
- If an action step is preceded by “(Trained service technician only),” that step must be performed only by a Trained service technician.
- Go to the IBM support website at <http://www.ibm.com/supportportal/> to check for technical information, hints, tips, and new device drivers or to submit a request for information.

Symptom	Action
A problem occurs only occasionally and is difficult to diagnose.	<ol style="list-style-type: none"> 1. Make sure that: <ul style="list-style-type: none"> • All cables and cords are connected securely to the rear of the server and attached devices. • When the server is turned on, air is flowing from the fan grille. If there is no airflow, the fan is not working. This can cause the server to overheat and shut down. 2. Check the system-error log or IMM system event log (see “Event logs” on page 27).
The server resets (restarts) occasionally.	<ol style="list-style-type: none"> 1. If the reset occurs during POST and the POST watchdog timer is enabled (click System Settings > Integrated Management Module > POST Watchdog Timer in the Setup utility to see the POST watchdog setting), make sure that sufficient time is allowed in the watchdog timeout value (POST Watchdog Timer). If the server continues to reset during POST, see “POST error codes” on page 242 and “Diagnostic messages” on page 257. 2. If the reset occurs after the operating system starts, disable any automatic server restart (ASR) utilities, such as the IBM Automatic Server Restart IPMI Application for Windows, or any ASR devices that are be installed. Note: ASR utilities operate as operating-system utilities and are related to the IPMI device driver. If the reset continues to occur after the operating system starts, the operating system might have a problem; see “Software problems” on page 308. 3. If neither condition applies, check the system-error log or IMM system-event log (see “Event logs” on page 27).

Keyboard, mouse, or pointing-device problems

Use this information to solve keyboard, mouse, or pointing-device problems.

- Follow the suggested actions in the order in which they are listed in the Action column until the problem is solved.
- See Chapter 4, “Parts listing, IBM System x3550 M3 Type 4254 and 7944,” on page 333 to determine which components are customer replaceable units (CRU) and which components are field replaceable units (FRU).
- If an action step is preceded by “(Trained service technician only),” that step must be performed only by a Trained service technician.
- Go to the IBM support website at <http://www.ibm.com/supportportal/> to check for technical information, hints, tips, and new device drivers or to submit a request for information.

Symptom	Action
All or some keys on the keyboard do not work.	<ol style="list-style-type: none"> 1. Make sure that: <ul style="list-style-type: none"> • The keyboard cable is securely connected. • The server and the monitor are turned on. 2. If you are using a USB keyboard, run the Setup utility and enable keyboardless operation. 3. If you are using a USB keyboard and it is connected to a USB hub, disconnect the keyboard from the hub and connect it directly to the server. 4. Replace the following components one at a time, in the order shown, restarting the server each time: <ol style="list-style-type: none"> a. Keyboard b. (Trained service technician only) System board
The mouse or pointing device does not work.	<ol style="list-style-type: none"> 1. Make sure that: <ul style="list-style-type: none"> • The mouse or pointing-device cable is securely connected to the server. • If you are using a pointing device, the keyboard and mouse or pointing-device cables are not reversed. • The mouse or pointing-device device drivers are installed correctly. • The server and the monitor are turned on. • The mouse option is enabled in the Setup utility. 2. If you are using a USB mouse or pointing device and it is connected to a USB hub, disconnect the mouse or pointing device from the hub and connect it directly to the server. 3. Replace the following components one at a time, in the order shown, restarting the server each time: <ol style="list-style-type: none"> a. Mouse or pointing device b. (Trained service technician only) System board

Memory problems

Use this information to solve memory problems.

- Follow the suggested actions in the order in which they are listed in the Action column until the problem is solved.
- See Chapter 4, “Parts listing, IBM System x3550 M3 Type 4254 and 7944,” on page 333 to determine which components are customer replaceable units (CRU) and which components are field replaceable units (FRU).
- If an action step is preceded by “(Trained service technician only),” that step must be performed only by a Trained service technician.
- For additional memory troubleshooting information, refer to the “Troubleshooting Memory - IBM BladeCenter and System x” document at <http://www.ibm.com/support/entry/portal/docdisplay?lnocid=MIGR-5081319>.
- Go to the IBM support website at <http://www.ibm.com/supportportal/> to check for technical information, hints, tips, and new device drivers or to submit a request for information.

Symptom	Action
The amount of system memory that is displayed is less than the amount of installed physical memory.	<p>Note: Each time you install or remove a DIMM, you must disconnect the server from the power source; then, wait 10 seconds before restarting the server.</p> <ol style="list-style-type: none"> 1. Make sure that: <ul style="list-style-type: none"> • No error LEDs are lit on the operator information panel. • No DIMM error LEDs are lit on the system board. • Memory mirroring does not account for the discrepancy. • The memory modules are seated correctly. • You have installed the correct type of memory. • If you changed the memory, you updated the memory configuration in the Setup utility. • All banks of memory are enabled. The server might have automatically disabled a memory bank when it detected a problem, or a memory bank might have been manually disabled. • There is no memory mismatch when the server is at the minimum memory configuration. 2. Reseat the DIMMs, and then restart the server. 3. Check the POST error log: <ul style="list-style-type: none"> • If a DIMM was disabled by a systems-management interrupt (SMI), replace the DIMM. • If a DIMM was disabled by the user or by POST, reseat the DIMM; then, run the Setup utility and enable the DIMM. 4. Check that all DIMMs are initialized in the Setup utility; then, run memory diagnostics (see “Running the diagnostic programs” on page 255). 5. Reverse the DIMMs between the channels (of the same microprocessor), and then restart the server. If the problem is related to a DIMM, replace the failing DIMM. 6. Re-enable all DIMMs using the Setup utility, and then restart the server. 7. (Trained service technician only) Install the failing DIMM into a DIMM connector for microprocessor 2 (if installed) to verify that the problem is not the microprocessor or the DIMM connector. 8. (Trained service technician only) Replace the system board.

- Follow the suggested actions in the order in which they are listed in the Action column until the problem is solved.
- See Chapter 4, “Parts listing, IBM System x3550 M3 Type 4254 and 7944,” on page 333 to determine which components are customer replaceable units (CRU) and which components are field replaceable units (FRU).
- If an action step is preceded by “(Trained service technician only),” that step must be performed only by a Trained service technician.
- For additional memory troubleshooting information, refer to the “Troubleshooting Memory - IBM BladeCenter and System x” document at <http://www.ibm.com/support/entry/portal/docdisplay?lnocid=MIGR-5081319>.
- Go to the IBM support website at <http://www.ibm.com/supportportal/> to check for technical information, hints, tips, and new device drivers or to submit a request for information.

Symptom	Action
<p>Multiple rows of DIMMs in a branch are identified as failing. Note: The highest-numbered DIMM failed disabling other DIMM(s) in the same channel.</p>	<p>Note: Each time you install or remove a DIMM, you must disconnect the server from the power source; then, wait 10 seconds before restarting the server.</p> <ol style="list-style-type: none"> 1. Reseat the DIMMs; then, restart the server. 2. Remove the DIMM with lit error LED and replace it with an identical known good DIMM; then, restart the server. Repeat as necessary. If the failures continue after all identified DIMMs are replaced, go to step 4. 3. Return the removed DIMMs, one at a time, to their original connectors, restarting the server after each DIMM, until a DIMM fails. Replace each failing DIMM with an identical known good DIMM, restarting the server after each DIMM replacement. Repeat step 3 until you have tested all removed DIMMs. 4. Replace the DIMM with lit error LED; then, restart the server. Repeat as necessary. 5. Reverse the DIMMs between the channels (of the same microprocessor), and then restart the server. If the problem is related to a DIMM, replace the failing DIMM. 6. (Trained service technician only) Install the failing DIMM into a DIMM connector for microprocessor 2 (if installed) to verify that the problem is not the microprocessor or the DIMM connector. 7. (Trained service technician only) Replace the system board.

Microprocessor problems

Use this information to solve microprocessor problems.

<ul style="list-style-type: none"> • Follow the suggested actions in the order in which they are listed in the Action column until the problem is solved. • See Chapter 4, "Parts listing, IBM System x3550 M3 Type 4254 and 7944," on page 333 to determine which components are customer replaceable units (CRU) and which components are field replaceable units (FRU). • If an action step is preceded by "(Trained service technician only)," that step must be performed only by a Trained service technician. • Go to the IBM support website at http://www.ibm.com/supportportal/ to check for technical information, hints, tips, and new device drivers or to submit a request for information. 	
Symptom	Action
The server goes directly to the POST Event Viewer when it is turned on.	<ol style="list-style-type: none"> 1. Correct any errors that are indicated by the light path diagnostics LEDs (see "Light path diagnostics" on page 309). 2. Make sure that the server supports all the microprocessors and that the microprocessors match in speed and cache size. To view the microprocessor information, run the Setup utility and select System Information > System Summary > Processor Details. 3. (Trained service technician only) Make sure that microprocessor 1 is seated correctly. 4. (Trained service technician only) Remove microprocessor 2 and restart the server. 5. Replace the following components one at a time, in the order shown, restarting the server each time: <ol style="list-style-type: none"> a. (Trained service technician only) Microprocessor b. (Trained service technician only) System board

Monitor and video problems

Use this information to solve monitor and video problems.

Some IBM monitors have their own self-tests. If you suspect a problem with your monitor, see the documentation that comes with the monitor for instructions for testing and adjusting the monitor. If you cannot diagnose the problem, call for service.

<ul style="list-style-type: none"> • Follow the suggested actions in the order in which they are listed in the Action column until the problem is solved. • See Chapter 4, "Parts listing, IBM System x3550 M3 Type 4254 and 7944," on page 333 to determine which components are customer replaceable units (CRU) and which components are field replaceable units (FRU). • If an action step is preceded by "(Trained service technician only)," that step must be performed only by a Trained service technician. • Go to the IBM support website at http://www.ibm.com/supportportal/ to check for technical information, hints, tips, and new device drivers or to submit a request for information. 	
Symptom	Action
Testing the monitor.	<ol style="list-style-type: none"> 1. Make sure that the monitor cables are firmly connected. 2. Try using a different monitor on the server, or try using the monitor that is being tested on a different server. 3. Run the diagnostic programs. If the monitor passes the diagnostic programs, the problem might be a video device driver. 4. (Trained service technician only) Replace the system board.

- Follow the suggested actions in the order in which they are listed in the Action column until the problem is solved.
- See Chapter 4, “Parts listing, IBM System x3550 M3 Type 4254 and 7944,” on page 333 to determine which components are customer replaceable units (CRU) and which components are field replaceable units (FRU).
- If an action step is preceded by “(Trained service technician only),” that step must be performed only by a Trained service technician.
- Go to the IBM support website at <http://www.ibm.com/supportportal/> to check for technical information, hints, tips, and new device drivers or to submit a request for information.

Symptom	Action
The screen is blank.	<ol style="list-style-type: none"> 1. If the server is attached to a KVM switch, bypass the KVM switch to eliminate it as a possible cause of the problem: connect the monitor cable directly to the correct connector on the rear of the server. 2. The IMM remote presence function is disabled if you install an optional video adapter. To use the IMM remote presence function, remove the optional video adapter. 3. Make sure that: <ul style="list-style-type: none"> • The server is turned on. If there is no power to the server, see “Power problems” on page 304. • The monitor cables are connected correctly. • The monitor is turned on and the brightness and contrast controls are adjusted correctly. 4. Make sure that the correct server is controlling the monitor, if applicable. 5. Make sure that damaged server firmware is not affecting the video; see “Updating the firmware” on page 455. 6. Observe the checkpoint LEDs on the system board; if the codes are changing, go to step 6. 7. Replace the following components one at a time, in the order shown, restarting the server each time: <ol style="list-style-type: none"> a. Monitor b. Video adapter (if one is installed) c. (Trained service technician only) System board. 8. See “Solving undetermined problems” on page 329.
The monitor works when you turn on the server, but the screen goes blank when you start some application programs.	<ol style="list-style-type: none"> 1. Make sure that: <ul style="list-style-type: none"> • The application program is not setting a display mode that is higher than the capability of the monitor. • You installed the necessary device drivers for the application. 2. Run video diagnostics (see “Running the diagnostic programs” on page 255). <ul style="list-style-type: none"> • If the server passes the video diagnostics, the video is good; see “Solving undetermined problems” on page 329. • (Trained service technician only) If the server fails the video diagnostics, replace the system board.

- Follow the suggested actions in the order in which they are listed in the Action column until the problem is solved.
- See Chapter 4, “Parts listing, IBM System x3550 M3 Type 4254 and 7944,” on page 333 to determine which components are customer replaceable units (CRU) and which components are field replaceable units (FRU).
- If an action step is preceded by “(Trained service technician only),” that step must be performed only by a Trained service technician.
- Go to the IBM support website at <http://www.ibm.com/supportportal/> to check for technical information, hints, tips, and new device drivers or to submit a request for information.

Symptom	Action
<p>The monitor has screen jitter, or the screen image is wavy, unreadable, rolling, or distorted.</p>	<ol style="list-style-type: none"> 1. If the monitor self-tests show that the monitor is working correctly, consider the location of the monitor. Magnetic fields around other devices (such as transformers, appliances, fluorescents, and other monitors) can cause screen jitter or wavy, unreadable, rolling, or distorted screen images. If this happens, turn off the monitor. Attention: Moving a color monitor while it is turned on might cause screen discoloration. Move the device and the monitor at least 305 mm (12 in.) apart, and turn on the monitor. Notes: <ol style="list-style-type: none"> a. To prevent diskette drive read/write errors, make sure that the distance between the monitor and any external diskette drive is at least 76 mm (3 inch). b. Non-IBM monitor cables might cause unpredictable problems. 2. Reseat the monitor cable. 3. Replace the components listed in step 2 one at a time, in the order shown, restarting the server each time: <ol style="list-style-type: none"> a. Monitor cable b. Video adapter (if one is installed) c. Monitor d. (Trained service technician only) System board.
<p>Wrong characters appear on the screen.</p>	<ol style="list-style-type: none"> 1. If the wrong language is displayed, update the server firmware to the latest level (see “Updating the firmware” on page 455) with the correct language. 2. Reseat the monitor cable. 3. Replace the components listed in step 2 one at a time, in the order shown, restarting the server each time: <ol style="list-style-type: none"> a. Monitor cable b. Video adapter (if one is installed) c. Monitor d. (Trained service technician only) System board.

Optional-device problems

Use this information to solve optional-device problems.

<ul style="list-style-type: none"> • Follow the suggested actions in the order in which they are listed in the Action column until the problem is solved. • See Chapter 4, “Parts listing, IBM System x3550 M3 Type 4254 and 7944,” on page 333 to determine which components are customer replaceable units (CRU) and which components are field replaceable units (FRU). • If an action step is preceded by “(Trained service technician only),” that step must be performed only by a Trained service technician. • Go to the IBM support website at http://www.ibm.com/supportportal/ to check for technical information, hints, tips, and new device drivers or to submit a request for information. 	
Symptom	Action
An IBM optional device that was just installed does not work.	<ol style="list-style-type: none"> 1. Make sure that: <ul style="list-style-type: none"> • The device is designed for the server (see http://www.ibm.com/systems/info/x86servers/serverproven/compat/us/). • You followed the installation instructions that came with the device and the device is installed correctly. • You have not loosened any other installed devices or cables. • You updated the configuration information in the Setup utility. Whenever memory or any other device is changed, you must update the configuration. 2. Reseat the device that you just installed. 3. Replace the device that you just installed.
An IBM optional device that worked previously does not work now.	<ol style="list-style-type: none"> 1. Make sure that all of the cable connections for the device are secure. 2. If the device comes with test instructions, use those instructions to test the device. 3. If the failing device is a SCSI device, make sure that: <ul style="list-style-type: none"> • The cables for all external SCSI devices are connected correctly. • The last device in each SCSI chain, or the end of the SCSI cable, is terminated correctly. • Any external SCSI device is turned on. You must turn on an external SCSI device before you turn on the server. 4. Reseat the failing device. 5. Replace the failing device.

Power problems

Use this information to solve power problems.

- Follow the suggested actions in the order in which they are listed in the Action column until the problem is solved.
- See Chapter 4, “Parts listing, IBM System x3550 M3 Type 4254 and 7944,” on page 333 to determine which components are customer replaceable units (CRU) and which components are field replaceable units (FRU).
- If an action step is preceded by “(Trained service technician only),” that step must be performed only by a Trained service technician.
- Go to the IBM support website at <http://www.ibm.com/supportportal/> to check for technical information, hints, tips, and new device drivers or to submit a request for information.

Symptom	Action
<p>The power-control button does not work, and the reset button does work (the server does not start).</p> <p>Note: The power-control button will not function until approximately 20 to 40 seconds after the server has been connected to power.</p>	<ol style="list-style-type: none"> 1. Make sure that the power-control button is working correctly: <ol style="list-style-type: none"> a. Disconnect the server power cords. b. Reconnect the power cords. c. (Trained service technician only) Reseat the operator information panel cables, and then repeat steps 1a and 1b. <ul style="list-style-type: none"> • (Trained service technician only) If the server starts, reseal the operator information panel. If the problem remains, replace the operator information panel. • If the server does not start, bypass the power-control button by using the force power-on jumper (see “System-board switches and jumpers” on page 19). If the server starts, reseal the operator information panel. If the problem remains, replace the operator information panel. 2. Make sure that the reset button is working correctly: <ol style="list-style-type: none"> a. Disconnect the server power cords. b. Reconnect the power cords. c. (Trained service technician only) Reseat the light path diagnostics panel cable, and then repeat steps 1a and 1b. <ul style="list-style-type: none"> • (Trained service technician only) If the server starts, replace the light path diagnostics panel. • If the server does not start, go to step 3. 3. Make sure that both power supplies installed in the server are of the same type. Mixing different power supplies in the server will cause a system error (the system-error LED on the front panel turns on and the PS and CNFG LEDs on the operator information panel are lit). 4. Make sure that: <ul style="list-style-type: none"> • The power cords are correctly connected to the server and to a working electrical outlet. • The type of memory that is installed is correct. • The DIMMs are fully seated. • The LEDs on the power supply do not indicate a problem. • The microprocessors are installed in the correct sequence. 5. Reseat the following components: <ol style="list-style-type: none"> a. DIMMs b. Power supplies c. (Trained service technician only) Power switch connector 6. Replace the components listed in step 5 one at a time, in the order shown, restarting the server each time. 7. If you just installed an optional device, remove it, and restart the server. If the server now starts, you might have installed more devices than the power supply supports. 8. See “Power-supply LEDs” on page 319 and “Solving undetermined problems” on page 329.

- Follow the suggested actions in the order in which they are listed in the Action column until the problem is solved.
- See Chapter 4, “Parts listing, IBM System x3550 M3 Type 4254 and 7944,” on page 333 to determine which components are customer replaceable units (CRU) and which components are field replaceable units (FRU).
- If an action step is preceded by “(Trained service technician only),” that step must be performed only by a Trained service technician.
- Go to the IBM support website at <http://www.ibm.com/supportportal/> to check for technical information, hints, tips, and new device drivers or to submit a request for information.

Symptom	Action
The OVER SPEC LED on the light path diagnostics panel is lit, and the 12v channel A LED on the system board is lit.	<ol style="list-style-type: none"> 1. Turn off the server and disconnect the power from the server. 2. Remove the optical drive, fans, hard disk drives, and hard disk drive backplane. 3. Restart the server to see whether the problem remains. 4. Reinstall each device that you removed in step 2 one at a time, starting the server each time, to isolate the failing device. 5. Replace any failing device. 6. (Trained service technician only) Replace the system board.
The OVER SPEC LED on the light path diagnostics panel is lit, and the 12v channel B LED on the system board is lit.	<ol style="list-style-type: none"> 1. Turn off the server and disconnect the power from the server. 2. Remove the PCI riser card in connector 1, all DIMMs, and the microprocessor in socket 2. 3. Restart the server to see whether the problem remains. 4. Reinstall each device that you removed in step 2 one at a time, starting the server each time, to isolate the failing device. 5. Replace any failing device. 6. (Trained service technician only) Replace the system board.
The OVER SPEC LED on the light path diagnostics panel is lit, and the 12v channel C LED on the system board is lit.	<ol style="list-style-type: none"> 1. Turn off the server and disconnect the power from the server. 2. Remove the SAS/SATA RAID riser card, DIMMs in connectors 1 through 9, and the microprocessor in socket 1. Note: The server will not power-on when the microprocessor in socket 1 or 2 is not installed in the server. (Trained service technician only) Toggle the switch block (SW4), switch 3 to allow the server to power-on. See “System-board switches and jumpers” on page 19 for the location of the SW4 switch block on the system board. 3. Restart the server to see whether the problem remains. 4. Reinstall each device that you removed in step 2 one at a time, starting the server each time, to isolate the failing device. 5. Replace any failing device. 6. (Trained service technician only) Replace the system board.
The OVER SPEC LED on the light path diagnostics panel is lit, and the 12v channel D LED on the system board is lit.	<ol style="list-style-type: none"> 1. Turn off the server and disconnect the power from the server. 2. (Trained service technician only) Remove the microprocessor in socket 1. Note: The server will not power-on when the microprocessor in socket 1 or 2 is not installed in the server. (Trained service technician only) Toggle the switch block (SW4), switch 3 to allow the server to power-on. See “System-board switches and jumpers” on page 19 for the location of the SW4 switch block on the system board. 3. Restart the server to see whether the problem remains. 4. (Trained service technician only) Reinstall the microprocessor in socket 1 and restart the server. 5. Replace any failing device. 6. (Trained service technician only) Replace the system board.

- Follow the suggested actions in the order in which they are listed in the Action column until the problem is solved.
- See Chapter 4, “Parts listing, IBM System x3550 M3 Type 4254 and 7944,” on page 333 to determine which components are customer replaceable units (CRU) and which components are field replaceable units (FRU).
- If an action step is preceded by “(Trained service technician only),” that step must be performed only by a Trained service technician.
- Go to the IBM support website at <http://www.ibm.com/supportportal/> to check for technical information, hints, tips, and new device drivers or to submit a request for information.

Symptom	Action
The OVER SPEC LED on the light path diagnostics panel is lit, and the 12v channel E LED on the system board is lit.	<ol style="list-style-type: none"> 1. Turn off the server and disconnect the power from the server. 2. Remove the PCI riser card from PCI riser connector 2 and the microprocessor in socket 2. 3. Restart the server to see whether the problem remains. 4. Reinstall each device that you removed in step 2 one at a time, starting the server each time, to isolate the failing device. 5. Replace any failing device. 6. (Trained service technician only) Replace the system board.
The OVER SPEC LED on the light path diagnostics panel is lit, and the 12v channel AUX LED on the system board is lit.	<ol style="list-style-type: none"> 1. Turn off the server and disconnect the power from the server. 2. Remove all PCI Express and PCI-X cards, all PCI riser cards, the operator information panel, and the Ethernet adapter (if installed). Note: The server will not power-on when the microprocessor in socket 1 or 2 is not installed in the server. (Trained service technician only) Toggle the switch block (SW4), switch 3 to allow the server to power-on. See “System-board switches and jumpers” on page 19 for the location of the SW4 switch block on the system board. 3. Restart the server to see whether the problem remains. 4. Reinstall each device that was removed in step 2 one at a time, starting the server each time, to isolate the failing device. 5. Replace any failing device. 6. (Trained service technician only) Replace the system board.
The server does not turn off.	<ol style="list-style-type: none"> 1. Determine whether you are using an Advanced Configuration and Power Interface (ACPI) or a non-ACPI operating system. If you are using a non-ACPI operating system, complete the following steps: <ol style="list-style-type: none"> a. Press Ctrl+Alt+Delete. b. Turn off the server by pressing the power-control button and hold it down for 5 seconds. c. Restart the server. d. If the server fails POST and the power-control button does not work, disconnect the power cord for 20 seconds; then, reconnect the power cord and restart the server. 2. If the problem remains or if you are using an ACPI-aware operating system, suspect the system board.
The server unexpectedly shuts down, and the LEDs on the operator information panel are not lit.	See “Solving undetermined problems” on page 329.

Serial-device problems

Use this information to solve serial-device problems.

<ul style="list-style-type: none"> • Follow the suggested actions in the order in which they are listed in the Action column until the problem is solved. • See Chapter 4, “Parts listing, IBM System x3550 M3 Type 4254 and 7944,” on page 333 to determine which components are customer replaceable units (CRU) and which components are field replaceable units (FRU). • If an action step is preceded by “(Trained service technician only),” that step must be performed only by a Trained service technician. • Go to the IBM support website at http://www.ibm.com/supportportal/ to check for technical information, hints, tips, and new device drivers or to submit a request for information. 	
Symptom	Action
The number of serial ports that are identified by the operating system is less than the number of installed serial ports.	<ol style="list-style-type: none"> 1. Make sure that: <ul style="list-style-type: none"> • Each port is assigned a unique address in the Setup utility and none of the serial ports is disabled. • The serial-port adapter (if one is present) is seated correctly. 2. Reseat the serial port adapter. 3. Replace the serial port adapter.
A serial device does not work.	<ol style="list-style-type: none"> 1. Make sure that: <ul style="list-style-type: none"> • The device is compatible with the server. • The serial port is enabled and is assigned a unique address. • The device is connected to the correct connector (see “System-board internal connectors” on page 18). 2. Reseat the following components: <ol style="list-style-type: none"> a. Failing serial device b. Serial cable 3. Replace the components listed in step 2 one at a time, in the order shown, restarting the server each time. 4. (Trained service technician only) Replace the system board.

ServerGuide problems

Use this information to solve ServerGuide problems.

<ul style="list-style-type: none"> • Follow the suggested actions in the order in which they are listed in the Action column until the problem is solved. • See Chapter 4, “Parts listing, IBM System x3550 M3 Type 4254 and 7944,” on page 333 to determine which components are customer replaceable units (CRU) and which components are field replaceable units (FRU). • If an action step is preceded by “(Trained service technician only),” that step must be performed only by a Trained service technician. • Go to the IBM support website at http://www.ibm.com/supportportal/ to check for technical information, hints, tips, and new device drivers or to submit a request for information. 	
Symptom	Action
The <i>ServerGuide Setup and Installation</i> CD will not start.	<ol style="list-style-type: none"> 1. Make sure that the server supports the ServerGuide program and has a startable (bootable) CD or DVD drive. 2. If the startup (boot) sequence settings have been changed, make sure that the CD or DVD drive is first in the startup sequence. 3. If more than one CD or DVD drive is installed, make sure that only one drive is set as the primary drive. Start the CD from the primary drive.

<ul style="list-style-type: none"> • Follow the suggested actions in the order in which they are listed in the Action column until the problem is solved. • See Chapter 4, “Parts listing, IBM System x3550 M3 Type 4254 and 7944,” on page 333 to determine which components are customer replaceable units (CRU) and which components are field replaceable units (FRU). • If an action step is preceded by “(Trained service technician only),” that step must be performed only by a Trained service technician. • Go to the IBM support website at http://www.ibm.com/supportportal/ to check for technical information, hints, tips, and new device drivers or to submit a request for information. 	
Symptom	Action
The MegaRAID Storage Manager program cannot view all installed drives, or the operating system cannot be installed.	<ol style="list-style-type: none"> 1. Make sure that the hard disk drive is connected correctly. 2. Make sure that the SAS/SATA hard disk drive cables are securely connected.
The operating-system installation program continuously loops.	Make more space available on the hard disk.
The ServerGuide program will not start the operating-system CD.	Make sure that the operating-system CD is supported by the ServerGuide program. For a list of supported operating-system versions, go to http://www.ibm.com/support/entry/portal/docdisplay?lnodocid=SERV-GUIDE , click IBM Service and Support Site, click the link for your ServerGuide version, and scroll down to the list of supported Microsoft Windows operating systems.
The operating system cannot be installed; the option is not available.	Make sure that the server supports the operating system. If it does, either no logical drive is defined (SCSI RAID servers), or the ServerGuide System Partition is not present. Run the ServerGuide program and make sure that setup is complete.

Software problems

Use this information to solve software problems.

<ul style="list-style-type: none"> • Follow the suggested actions in the order in which they are listed in the Action column until the problem is solved. • See Chapter 4, “Parts listing, IBM System x3550 M3 Type 4254 and 7944,” on page 333 to determine which components are customer replaceable units (CRU) and which components are field replaceable units (FRU). • If an action step is preceded by “(Trained service technician only),” that step must be performed only by a Trained service technician. • Go to the IBM support website at http://www.ibm.com/supportportal/ to check for technical information, hints, tips, and new device drivers or to submit a request for information. 	
Symptom	Action
You suspect a software problem.	<ol style="list-style-type: none"> 1. To determine whether the problem is caused by the software, make sure that: <ul style="list-style-type: none"> • The server has the minimum memory that is needed to use the software. For memory requirements, see the information that comes with the software. If you have just installed an adapter or memory, the server might have a memory-address conflict. • The software is designed to operate on the server. • Other software works on the server. • The software works on another server. 2. If you received any error messages when using the software, see the information that comes with the software for a description of the messages and suggested solutions to the problem. 3. Contact the software vendor.

Universal Serial Bus (USB) port problems

Use this information to USB port problems.

- Follow the suggested actions in the order in which they are listed in the Action column until the problem is solved.
- See Chapter 4, “Parts listing, IBM System x3550 M3 Type 4254 and 7944,” on page 333 to determine which components are customer replaceable units (CRU) and which components are field replaceable units (FRU).
- If an action step is preceded by “(Trained service technician only),” that step must be performed only by a Trained service technician.
- Go to the IBM support website at <http://www.ibm.com/supportportal/> to check for technical information, hints, tips, and new device drivers or to submit a request for information.

Symptom	Action
A USB device does not work.	<ol style="list-style-type: none">1. Make sure that:<ul style="list-style-type: none">• The correct USB device driver is installed.• The operating system supports USB devices.2. Make sure that the USB configuration options are set correctly in the Setup utility (see “Using the Setup utility” on page 460 for more information).3. If you are using a USB hub, disconnect the USB device from the hub and connect it directly to the server.

Video problems

Use this information to solve video problems.

See “Monitor and video problems” on page 300.

Light path diagnostics

Light path diagnostics is a system of LEDs on various external and internal components of the server. When an error occurs, LEDs are lit throughout the server. By viewing the LEDs in a particular order, you can often identify the source of the error.

When LEDs are lit to indicate an error, they remain lit when the server is turned off, provided that the server is still connected to power and the power supply is operating correctly.

Before you work inside the server to view light path diagnostics LEDs, read the safety information that begins on “Safety” on page vii and “Handling static-sensitive devices” on page 350.

If an error occurs, view the light path diagnostics LEDs in the following order:

1. Look at the operator information panel on the front of the server.
 - If the information LED is lit, it indicates that information about a suboptimal condition in the server is available in the IMM system-event log or in the system-error log.
 - If the system-error LED is lit, it indicates that an error has occurred; go to step 2 on page 310.

The following illustration shows the operator information panel:

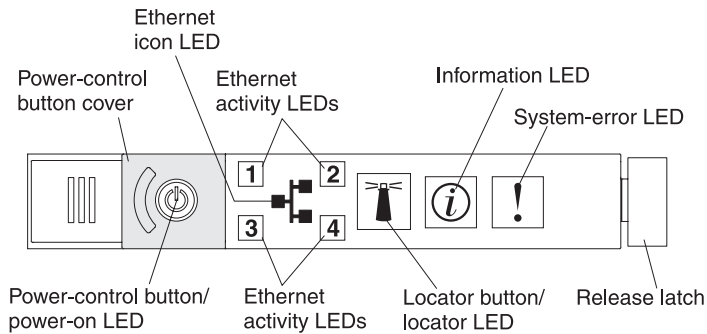

Figure 14. Operator information panel

- To view the light path diagnostics panel, slide the blue release latch on the operator panel to the left. Pull forward on the panel until the hinge of the operator panel is free of the server chassis. Then pull down on the panel so that you can view the light path diagnostics panel information. This reveals the light path diagnostics panel. Lit LEDs on this panel indicate the type of error that has occurred.

Note: When you slide the light path diagnostics panel out of the server to check the LEDs or checkpoint codes, do not run the server continuously with the light path diagnostics panel outside of the server. The panel should only be outside of the server a short time. The light path diagnostics panel must remain in the server when the server is running to ensure proper cooling.

The following illustration shows the light path diagnostics panel:

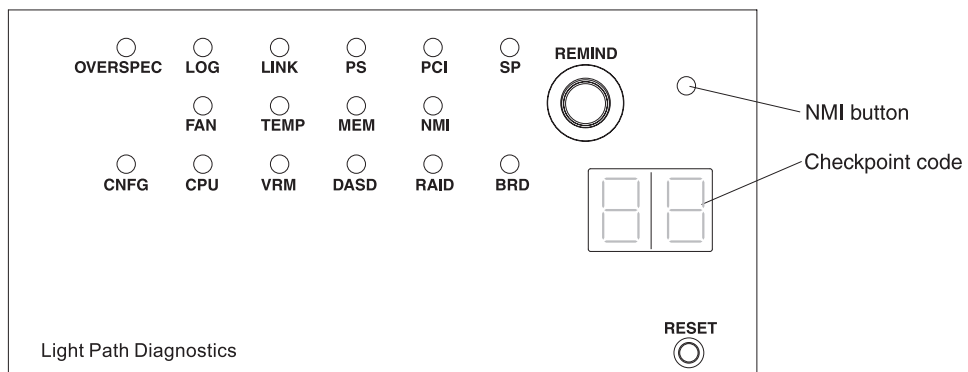

Figure 15. Light path diagnostics panel exposure

Note any LEDs that are lit, and then reinstall the light path diagnostics panel in the server.

Note: When you slide the light path diagnostics panel out of the server to check the LEDs or checkpoint codes, do not run the server continuously with the light path diagnostics panel outside of the server. The panel should only be outside of the server a short time. The light path diagnostics panel must remain in the server when the server is running to ensure proper cooling.

Look at the system service label inside the server cover, which gives an overview of internal components that correspond to the LEDs on the light path diagnostics panel. This information and the information in “Light path diagnostics LEDs” on page 312 can often provide enough information to diagnose the error.

- Remove the server cover and look inside the server for lit LEDs. Certain components inside the server have LEDs that are lit to indicate the location of a problem.

The following illustration shows the LEDs and connectors on the system board.

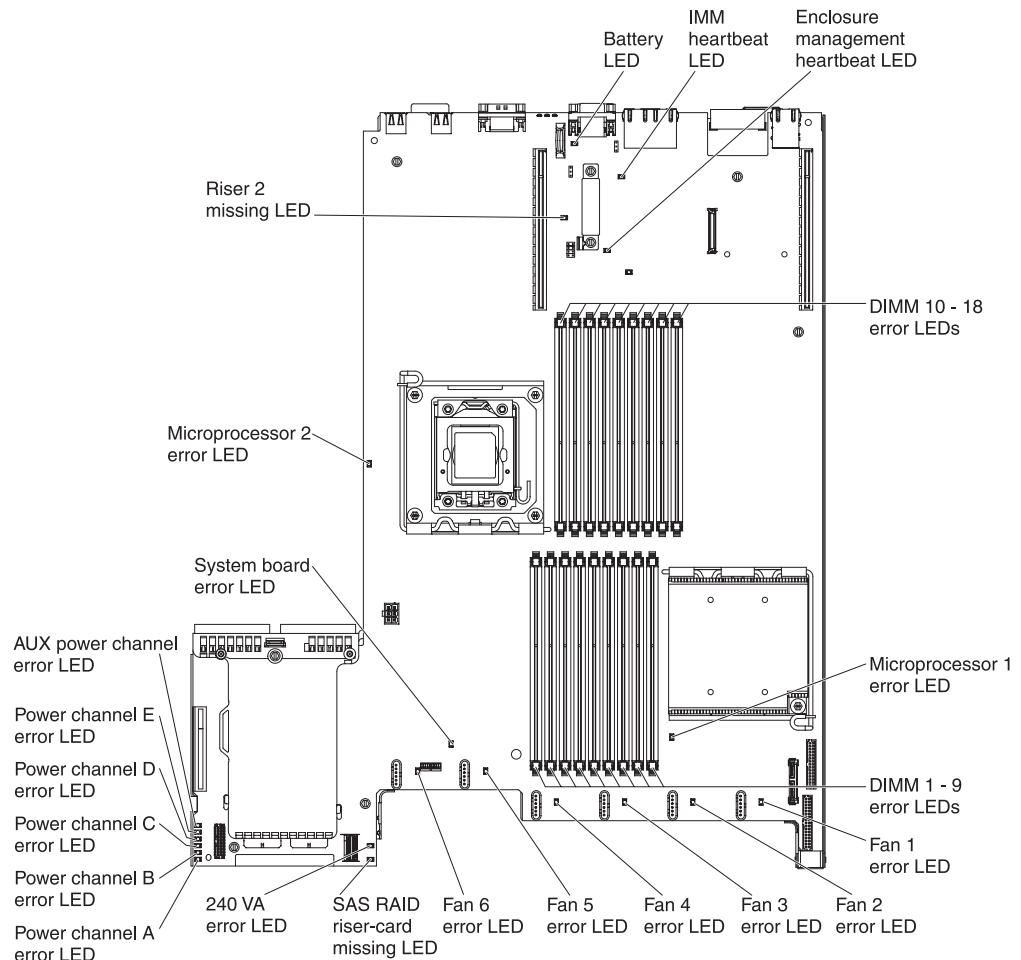

Figure 16. System-board LEDs

- Remind button:** Press this button to place the system-error LED on the front information panel into Remind mode. By placing the system-error LED indicator in Remind mode, you acknowledge that you are aware of the last failure but will not take immediate action to correct the problem. In Remind mode, the system-error LED flashes rapidly until one of the following conditions occurs:
 - All known errors are corrected.
 - The server is restarted.
 - A new error occurs, causing the system-error LED to be lit again.
- NMI button:** The NMI button on the front panel will come on when this button is pressed. Press this button to force a nonmaskable interrupt to the microprocessor. You might have to use a pen or the end of a straightened paper clip to press the button. It allows you to blue screen the server and take a memory dump (use this button only when directed by the IBM service support).
- Checkpoint code display:** This display provides a checkpoint code that indicates the point at which the system stopped during the boot block and POST. A

checkpoint code is either a byte or a word value that is produced by UEFI. The display does not provide error codes or suggest components to be replaced.

- **Reset button:** Press this button to reset the server and run the power-on self-test (POST). You might have to use a pen or the end of a straightened paper clip to press the button. The Reset button is in the lower-right corner of the light path diagnostics panel.

Light path diagnostics LEDs

The following table describes the LEDs on the light path diagnostics panel and suggested actions to correct the detected problems.

Note: Check the system-error log or system event log for additional information before replacing a FRU.

Table 10. Light path diagnostics panel LEDs

<ul style="list-style-type: none"> • Follow the suggested actions in the order in which they are listed in the Action column until the problem is solved. • See "Parts listing" to determine which components are customer replaceable units (CRU) and which components are field replaceable units (FRU). • If an action step is preceded by "(Trained service technician only)", that step must be performed only by a trained service technician. 		
LED	Description	Action
None, but the system error LED is lit.	An error has occurred and cannot be isolated. The error is not represented by a path.	Use the Setup utility to check the system error log for information about the error.

Table 10. Light path diagnostics panel LEDs (continued)

LED	Description	Action
OVER SPEC	The power supplies are using more power than their maximum rating.	<p>If the OVER SPEC LED on the light path diagnostics panel is lit, or any of the six 12 V channel error LEDs (A, B, C, D, E, or AUX) on the system board are lit, use one of the following procedures.</p> <p>If the 12 V channel A error LED is lit, complete the following steps:</p> <ol style="list-style-type: none"> 1. Turn off the server and disconnect the power from the server. 2. Remove the optical drive, fans, hard disk drives, and hard disk drive backplane. 3. Restart the server to see whether the problem remains. 4. Reinstall each device that you removed in step 2 one at a time, starting the server each time, to isolate the failing device. 5. Replace any failing device. 6. (Trained service technician only) Replace the system board. <p>If the 12 V channel B error LED is lit, complete the following steps:</p> <ol style="list-style-type: none"> 1. Turn off the server and disconnect the power from the server. 2. Remove the PCI riser card in connector 1, all DIMMs, and the microprocessor in socket 2. 3. Restart the server to see whether the problem remains. 4. Reinstall each device that you removed in step 2 one at a time, starting the server each time, to isolate the failing device. 5. Replace any failing device. 6. (Trained service technician only) Replace the system board. <p>(Continued on the next page)</p>

Table 10. Light path diagnostics panel LEDs (continued)

LED	Description	Action
OVER SPEC (Continued)	The power supplies are using more power than their maximum rating.	<p>If the 12 V channel C error LED is lit, complete the following steps:</p> <ol style="list-style-type: none"> 1. Turn off the server and disconnect the power from the server. 2. Remove the SAS/SATA RAID riser card, DIMMs in connectors 1 through 9, and the microprocessor in socket 1. Note: The server will not power-on when the microprocessor in socket 1 or 2 is not installed in the server. (Trained service technician only) Toggle the switch block (SW4), bit 3 to allow the server to power-on. See "System-board switches and jumpers" on page 19 for the location of the SW4 switch block on the system board. 3. Restart the server to see whether the problem remains. 4. Reinstall each device that you removed in step 2 one at a time, starting the server each time, to isolate the failing device. 5. Replace any failing device. 6. (Trained service technician only) Replace the system board. <p>If the 12 V channel D error LED is lit, complete the following steps:</p> <ol style="list-style-type: none"> 1. Turn off the server and disconnect the power from the server. 2. (Trained service technician only) Remove the microprocessor in socket 1. Note: The server will not power-on when the microprocessor in socket 1 or 2 is not installed in the server. (Trained service technician only) Toggle the switch block (SW4), bit 3 to allow the server to power-on. See "System-board switches and jumpers" on page 19 for the location of the SW4 switch block on the system board. 3. Restart the server to see whether the problem remains. 4. (Trained service technician only) Reinstall the microprocessor in socket 1 and restart the server. 5. Replace any failing device. 6. (Trained service technician only) Replace the system board. <p>(Continued on the next page.)</p>

Table 10. Light path diagnostics panel LEDs (continued)

LED	Description	Action
OVER SPEC (Continued)	The power supplies are using more power than their maximum rating.	<p>If the 12 V channel E error LED is lit, complete the following steps:</p> <ol style="list-style-type: none"> 1. Turn off the server and disconnect the power from the server. 2. Remove the PCI riser card from PCI riser connector 2 and the microprocessor in socket 2. 3. Restart the server to see whether the problem remains. 4. Reinstall each device that you removed in step 2 one at a time, starting the server each time, to isolate the failing device. 5. Replace any failing device. 6. (Trained service technician only) Replace the system board. <p>If the 12 V AUX channel error LED is lit, complete the following steps:</p> <ol style="list-style-type: none"> 1. Turn off the server and disconnect the power from the server. 2. Remove all PCI Express and PCI-X cards, all PCI riser cards, the operator information panel, and the Ethernet adapter (if installed). Note: The server will not power-on when the microprocessor in socket 1 or 2 is not installed in the server. (Trained service technician only) Toggle the switch block (SW4), bit 3 to allow the server to power-on. See "System-board switches and jumpers" on page 19 for the location of the SW4 switch block on the system board. 3. Restart the server to see whether the problem remains. 4. Reinstall each device that was removed in step 2 one at a time, starting the server each time, to isolate the failing device. 5. Replace any failing device. 6. (Trained service technician only) Replace the system board.
LOG	An error occurred.	Check the IMM system event log and the system-error log for information about the error. Replace any components that are identified in the error logs.
LINK	Reserved.	

Table 10. Light path diagnostics panel LEDs (continued)

LED	Description	Action
PS	Power supply 1 or 2 has failed. When both the PS and CNFG LEDs are lit, the power supply configuration is invalid.	<ol style="list-style-type: none"> 1. Check the power-supply that has an lit amber LED (see "Power-supply LEDs" on page 319). 2. Make sure that the power supplies are seated correctly. 3. Remove one of the power supplies to isolate the failed power supply. 4. Make sure that both power supplies installed in the server are of the same type. 5. Replace the failed power supply.
PCI	An error has occurred on a PCI bus or on the system board. An additional LED is lit next to a failing PCI slot.	<ol style="list-style-type: none"> 1. Check the LEDs on the PCI slots to identify the component that caused the error. 2. Check the system-error log for information about the error. 3. If you cannot isolate the failing adapter by using the LEDs and the information in the system-error log, remove one adapter at a time from the failing PCI bus; and restart the server after each adapter is removed. 4. Replace the following components, in the order shown, restarting the server each time: <ul style="list-style-type: none"> • PCI riser card • (Trained service technician only) Replace the system board. 5. For more information, go to http://www.ibm.com/support/entry/portal/docdisplay?lnocid=SERV-CALL.
SP	A service processor error has been detected.	<ol style="list-style-type: none"> 1. Shut down the system and remove the power cords from the server; then, reconnect the server to power and restart the server. 2. Update the IMM firmware. 3. (Trained service technician only) Replace the system board, if the problem remains. 4. For more information, go to http://www.ibm.com/support/entry/portal/docdisplay?lnocid=SERV-CALL.
FAN	A fan has failed, is operating too slowly, or has been removed. The TEMP LED might also be lit.	<ol style="list-style-type: none"> 1. Reseat the failing fan, which is indicated by a lit LED near the fan connector on the system board. 2. Replace the failing fan, which is indicated by a lit LED near the fan connector on the system board. Note: If an LED near an unused fan connector on the system board is lit, a PCI riser-card assembly might be absent. Replace the PCI riser-card assembly. One PCI riser-card assembly must always be present in PCI connector 2.

Table 10. Light path diagnostics panel LEDs (continued)

LED	Description	Action
TEMP	The system temperature has exceeded a threshold level. A failing fan can cause the TEMP LED to be lit.	<ol style="list-style-type: none"> 1. Make sure that the heat sink is seated correctly. 2. Determine whether a fan has failed. If it has, replace it. 3. Make sure that the room temperature is not too high. See "Features and specifications" on page 7 for the server temperature information. 4. Make sure that the air vents are not blocked. 5. For more information, go to http://www.ibm.com/support/entry/portal/docdisplay?lnocid=SERV-CALL.
MEM	When only the MEM LED is lit, a memory error has occurred. When both the MEM and CNFG LEDs are lit, the memory configuration is invalid or the PCI Option ROM is out of resource.	<p>Note: Each time you install or remove a DIMM, you must disconnect the server from the power source; then, wait 10 seconds before restarting the server.</p> <ol style="list-style-type: none"> 1. If the MEM LED and the CNFG LED are lit, complete the following step: <ol style="list-style-type: none"> a. Check the system-event log in the Setup utility or IMM error messages. 2. If the CNFG LED is not lit, the system might detect a memory error. Complete the following steps to correct the problem: <ol style="list-style-type: none"> a. Update the server firmware to the latest level. b. Reseat or swap the DIMMs. c. Check the system-event log in the Setup utility or IMM error messages.
NMI	A nonmaskable interrupt has occurred, or the NMI button was pressed.	Check the system-error log for information about the error.
CNFG	A hardware configuration error has occurred.	<ol style="list-style-type: none"> 1. If the CNFG LED and the CPU LED are lit, complete the following steps to correct the problem: <ol style="list-style-type: none"> a. Check the microprocessors that were just installed to make sure that they are compatible with each other. b. (Trained service technician only) Replace the incompatible microprocessor. c. Check the system-error logs for information about the error. Replace any components that are identified in the error log. 2. If the CNFG LED and the MEM LED are lit, complete the following step: <ol style="list-style-type: none"> a. Check the system-event log in the Setup utility or IMM error messages. 3. If the CNFG LED and the PS LED are lit, the system issues an invalid power configuration error. Make sure that both power supplies installed in the server are of the same type.

Table 10. Light path diagnostics panel LEDs (continued)

LED	Description	Action
CPU	An invalid microprocessor configuration or a microprocessor has failed (both the CPU LED and the CNFG LED might be lit).	<ul style="list-style-type: none"> 1. If the CNFG LED is lit, the system issues an invalid microprocessor configuration error. Complete the following steps to correct the problem: <ul style="list-style-type: none"> a. Check the microprocessors that were just installed to make sure that they are compatible with each other and use the Setup utility and select System Information > System Summary > Processor Details to verify the microprocessors information. b. (Trained service technician only) Replace the incompatible microprocessor. c. Check the system-error logs for information about the error. Replace any components that are identified in the error log. 2. If a microprocessor failure occurs, complete the following steps: <ul style="list-style-type: none"> a. (Trained service technician only) Make sure that the failing microprocessor, which is indicated by a lit LED on the system board, is installed correctly. b. For more information, go to http://www.ibm.com/support/entry/portal/docdisplay?lnocid=SERV-CALL.
VRM	Reserved.	
DASD	A hard disk drive has failed or is missing.	<ul style="list-style-type: none"> 1. Check the LEDs on the hard disk drives for the drive with a lit status LED and reseal the hard disk drive. 2. Reseat the hard disk drive backplane. 3. For more information, see the "Hard disk drive problems". 4. If the error remains, replace the following components in the order listed, restarting the server after each: <ul style="list-style-type: none"> a. Replace the hard disk drive. b. Replace the hard disk drive backplane. 5. If the error remains, replace the following components one at a time, in the order listed, restarting the server after each: <ul style="list-style-type: none"> a. Replace the hard disk drive. b. Replace the hard disk drive backplane. 6. If the problem remains, go to http://www.ibm.com/support/entry/portal/docdisplay?lnocid=SERV-CALL.
RAID	Reserved.	

Table 10. Light path diagnostics panel LEDs (continued)

<ul style="list-style-type: none"> • Follow the suggested actions in the order in which they are listed in the Action column until the problem is solved. • See “Parts listing” to determine which components are customer replaceable units (CRU) and which components are field replaceable units (FRU). • If an action step is preceded by “(Trained service technician only)”, that step must be performed only by a trained service technician. 		
LED	Description	Action
BRD	An error has occurred on the system board.	<ol style="list-style-type: none"> 1. Check the LEDs on the system board to identify the component that caused the error. The BRD LED can be lit due to any of the following reasons: <ul style="list-style-type: none"> • Battery • Missing PCI riser-card assembly • Failed voltage regulator 2. Check the system-error log for information about the error. 3. Replace any failed or missing replacement components, such as the battery or PCI riser-card assembly. 4. If a voltage regulator has failed, (trained service technician only) replace the system board.

Power-supply LEDs

Use this information to view power-supply LEDs.

The following minimum configuration is required for the server to start:

- One microprocessor in microprocessor socket 1
- One 2 GB DIMM for each microprocessor installed (one 2 GB DIMM in slot 3 if only one microprocessor installed)
- One power supply
- Power cord
- Five cooling fans (fan 1, 2, 3, 4, and 5)
- One PCI riser-card assembly in PCI connector 2
- One ServeRAID SAS/SATA controller

AC power-supply LEDs

Use this information to view AC power-supply LEDs.

The following illustration shows the location of the AC power-supply LEDs on the rear of the server. See the *Problem Determination and Service Guide* for additional information about solving power-supply problems.

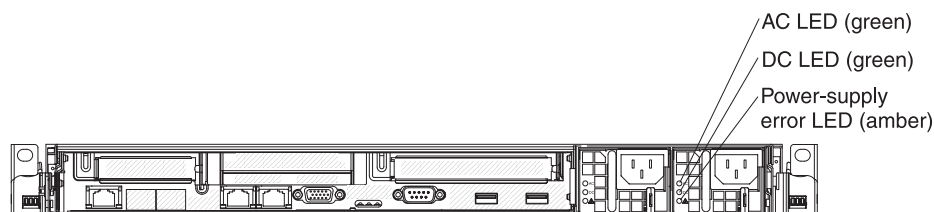

Figure 17. AC power-supply LEDs

The following table describes the problems that are indicated by various combinations of the power-supply LEDs on an ac power supply and suggested actions to correct the detected problems.

AC power-supply LEDs			Description	Action	Notes
AC	DC	Error (!)			
On	On	Off	Normal operation		
Off	Off	Off	No ac power to the server or a problem with the ac power source.	<ol style="list-style-type: none"> 1. Check the ac power to the server. 2. Make sure that the power cord is connected to a functioning power source. 3. Restart the server. If the error remains, check the power-supply LEDs. 4. Replace the power-supply. 	This is a normal condition when no ac power is present.
Off	Off	On	No ac power to the server or a problem with the ac power source and the power-supply had detected an internal problem.	<ul style="list-style-type: none"> • Make sure that the power cord is connected to a functioning power source. • Replace the power supply. 	This happens only when a second power supply is providing power to the server.
Off	On	Off	Faulty power-supply	Replace the power supply.	
Off	On	On	Faulty power-supply	Replace the power supply.	
On	Off	Off	Power-supply not fully seated, faulty system board, or faulty power-supply	<ol style="list-style-type: none"> 1. Reseat the power supply. 2. If a power channel error LED on the system board is not lit, replace the power-supply (see the documentation that comes with the power supply for instructions). 3. If a power channel error LED on the system board is lit, (trained service technician only) replace the system board. 	Typically indicates a power-supply is not fully seated.
On	Off	On	Faulty power-supply	Replace the power supply.	
On	On	On	Power-supply is faulty but still operational	Replace the power supply.	

DC power-supply LEDs

Use this information to view DC power-supply LEDs.

The following illustration shows the locations of the power-supply LEDs on the dc power supply.

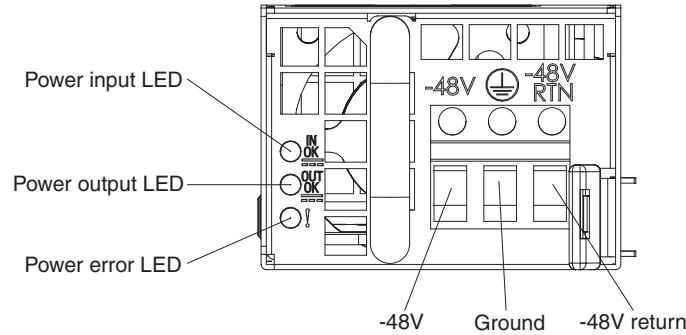

Figure 18. DC power-supply LEDs

The following table describes the problems that are indicated by various combinations of the power-supply LEDs on a dc power supply and suggested actions to correct the detected problems.

DC power-supply LEDs			Description	Action	Notes
IN OK	OUT OK	Error (!)			
On	On	Off	Normal operation		
Off	Off	Off	No dc power to the server or a problem with the dc power source.	<ol style="list-style-type: none"> 1. Check the dc power to the server. 2. Make sure that the power cord is connected to a functioning power source. 3. Restart the server. If the error remains, check the power-supply LEDs. 4. Replace the power-supply. 	This is a normal condition when no dc power is present.
Off	Off	On	No dc power to the server or a problem with the dc power source and the power-supply had detected an internal problem.	<ul style="list-style-type: none"> • Make sure that the power cord is connected to a functioning power source. • Replace the power supply (see the documentation that comes with the power supply for instructions). 	
Off	On	Off	Faulty power-supply	Replace the power supply.	
Off	On	On	Faulty power-supply	Replace the power supply.	

DC power-supply LEDs			Description	Action	Notes
IN OK	OUT OK	Error (!)			
On	Off	Off	Power-supply not fully seated, faulty system board, or faulty power-supply	<ol style="list-style-type: none"> 1. (Trained service technician only) Reseat the power supply. 2. If a power channel error LED on the system board is not lit, replace the power-supply (see the documentation that comes with the power supply for instructions). 3. If a power channel error LED on the system board is lit, (trained service technician only) replace the system board. 	Typically indicates a power-supply is not fully seated.
On	Off	On	Faulty power-supply	Replace the power supply.	
On	On	On	Power-supply is faulty but still operational	Replace the power supply.	

System pulse LEDs

The following LEDs are on the system board and monitors the system power-on and power-off sequencing and boot progress.

See "System-board LEDs" on page 22 for the location of these LEDs.

Table 11. System pulse LEDs

LED	Description	Action
Enclosure management heartbeat	Power-on and power-off sequencing.	<ol style="list-style-type: none"> 1. If the LED blinks at 1Hz, it is functioning properly and no action is necessary. 2. If the LED is not blinking, (trained service technician only) replace the system board.

Table 11. System pulse LEDs (continued)

LED	Description	Action
IMM heartbeat	IMM heartbeat boot process.	<p>The following steps describe the different stages of the IMM heartbeat sequencing process.</p> <ol style="list-style-type: none"> 1. When this LED is blinking fast (approximately 4Hz), this indicates, that the IMM code is in the loading process. 2. When this LED goes off momentarily, this indicates that the IMM code has loaded completely. 3. When this LED goes off momentarily and then starts blinking slowing (approximately 1Hz), this indicates that IMM is fully operational. You can now press the power-control button to power-on the server. 4. If this LED does not blink within 30 seconds of connecting a power source to the server, complete the following steps: <ol style="list-style-type: none"> a. (Trained service technician only) use the IMM recovery jumper to recover the firmware (see "System-board switches and jumpers" on page 19). b. (Trained service technician only) replace the system board.

Recovering the server firmware

Use this information to recover the server firmware.

Important: Some cluster solutions require specific code levels or coordinated code updates. If the device is part of a cluster solution, verify that the latest level of code is supported for the cluster solution before you update the code.

If the server firmware has become corrupted, such as from a power failure during an update, you can recover the server firmware in one of two ways:

- **In-band method:** Recover server firmware, using either the boot block jumper (Automated Boot Recovery) and a server Firmware Update Package Service Pack.
- **Out-of-band method:** Use the IMM Web Interface to update the firmware, using the latest server firmware update package.

Note: You can obtain a server update package from one of the following sources:

- Download the server firmware update from the World Wide Web.
- Contact your IBM service representative.

To download the server firmware update package from the World Wide Web, go to <http://www.ibm.com/supportportal/>.

The flash memory of the server consists of a primary bank and a backup bank. It is essential that you maintain the backup bank with a bootable firmware image. If the primary bank becomes corrupted, you can either manually boot the backup bank with the boot block jumper, or in the case of image corruption, this will occur automatically with the Automated Boot Recovery function.

In-band manual recovery method

Use this information to recover the server firmware and restore the server operation to the primary bank.

About this task

To recover the server firmware and restore the server operation to the primary bank, complete the following steps:

Procedure

1. Read the safety information that begins on page "Safety" on page vii and "Handling static-sensitive devices" on page 350.
2. Turn off the server, and disconnect all power cords and external cables.
3. Remove the server cover. See "Removing the cover" on page 356 for more information.
4. Locate the UEFI boot recovery jumper block (J29) on the system board.

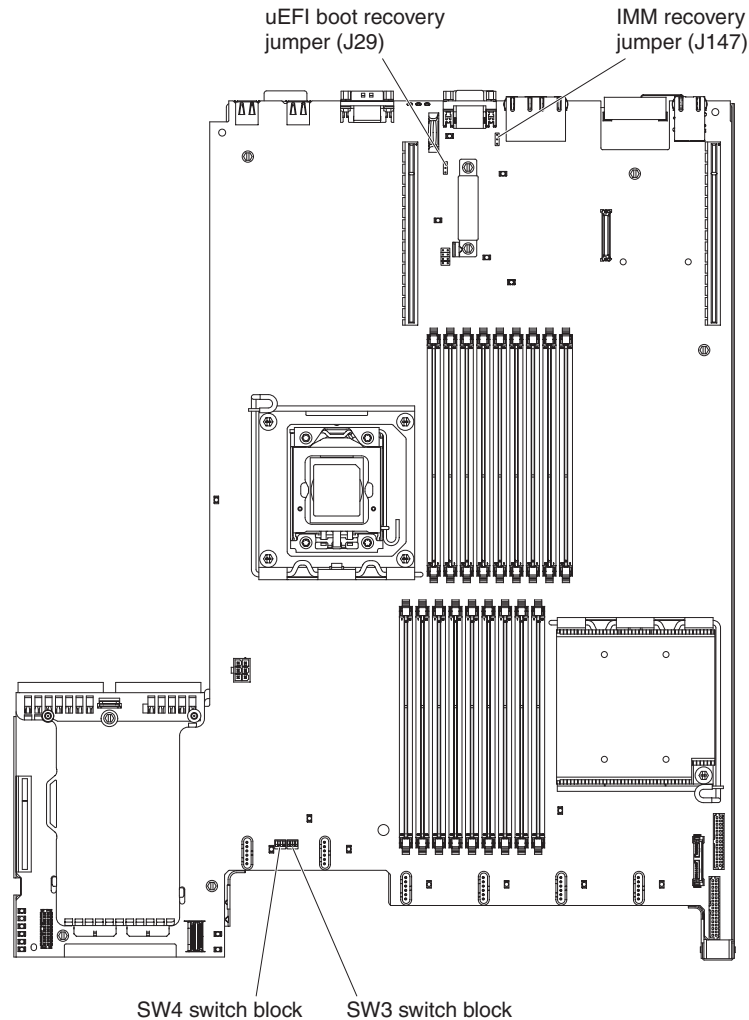

Figure 19. UEFI boot recovery jumper block (J29) location

5. Remove any adapters that impede access to the UEFI boot recovery jumper block (J29), see “Removing an adapter” on page 381.
6. Move the jumper from pins 1 and 2 to pins 2 and 3 to enable the UEFI recovery mode.
7. Reinstall any adapter that you removed before (see “Replacing an adapter” on page 382).
8. Reinstall the server cover (see “Installing the cover” on page 357); then, reconnect all power cords.
9. Restart the server. The power-on self-test (POST) starts.
10. Boot the server to an operating system that is supported by the firmware update package that you downloaded.
11. Perform the firmware update by following the instructions that are in the firmware update package readme file.
12. Copy the downloaded firmware update package into a directory.
13. From a command line, type `filename -s`, where *filename* is the name of the executable file that you downloaded with the firmware update package. Monitor the firmware update until completion.
14. Turn off the server and disconnect all power cords and external cables, and then remove the server cover (see “Removing the cover” on page 356).

15. Remove any adapters that impede access to the UEFI boot recovery jumper block (J29) (see “Replacing an adapter” on page 382).
16. Move the UEFI boot recovery jumper from pins 2 and 3 back to the primary position (pins 1 and 2).
17. Reinstall any adapter that you removed before (see “Replacing an adapter” on page 382).
18. Reinstall the server cover (see “Installing the cover” on page 357); then, reconnect all power cords.
19. Restart the server. The power-on self-test (POST) starts. If this does not recover the primary bank, continue with the following steps.
20. Remove the server cover (see “Removing the cover” on page 356).
21. Reset the CMOS by removing the system battery (see “Removing the system battery” on page 415).
22. Leave the system battery out of the server for approximately 5 to 15 minutes.
23. Reinstall the system battery (see “Installing the system battery” on page 417).
24. Reinstall the server cover (see “Installing the cover” on page 357); then, reconnect all power cords.
25. Restart the server. The power-on self-test (POST) starts.
26. If these recovery efforts fail, contact your IBM service representative for support.

Results

See “System-board switches and jumpers” on page 19 for more information about the switches and jumpers.

In-band automated boot recovery method

Use this information to recover the server firmware and restore the server operation to the primary bank.

About this task

Note: Use this method if the BRD LED on the light path diagnostics panel is lit and there is a log entry or Booting Backup Image is displayed on the firmware splash screen; otherwise, use the in-band manual recovery method.

Procedure

1. Boot the server to an operating system that is supported by the firmware update package that you downloaded.
2. Perform the firmware update by following the instructions that are in the firmware update package readme file.
3. Restart the server.
4. At the firmware splash screen, press F3 when prompted to restore to the primary bank. The server boots from the primary bank.

Out-of-band method

Use this information to recover the server firmware and restore the server operation to the primary bank.

See the IMM documentation (*Integrated Management Module User's Guide*) at www.ibm.com/support/entry/portal/docdisplay?lnocid=MIGR-5079770&brandind=5000008.

Automated boot recovery (ABR)

While the server is starting, if the integrated management module II detects problems with the server firmware in the primary bank, the server automatically switches to the backup firmware bank and gives you the opportunity to recover the firmware in the primary bank.

About this task

For instructions for recovering the UEFI firmware, see “Recovering the server firmware” on page 323. After you have recovered the firmware in the primary bank, complete the following steps:

Procedure

1. Restart the server.
2. When the prompt Press F3 to restore to primary is displayed, press F3 to start the server from the primary bank.

Nx boot failure

Configuration changes, such as added devices or adapter firmware updates, and firmware or application code problems can cause the server to fail POST (the power-on self-test).

If this occurs, the server responds in either of the following ways:

- The server restarts automatically and attempts POST again.
- The server hangs, and you must manually restart the server for the server to attempt POST again.

After a specified number of consecutive attempts (automatic or manual), the Nx boot failure feature causes the server to revert to the default UEFI configuration and start the Setup utility so that you can make the necessary corrections to the configuration and restart the server. If the server is unable to successfully complete POST with the default configuration, there might be a problem with the system board.

To specify the number of consecutive restart attempts that will trigger the Nx boot failure feature, in the Setup utility, click **System Settings > Operating Modes > POST Attempts Limit**. The available options are 3, 6, 9, and 255 (disable Nx boot failure).

Solving power problems

Use this information to solve power problems.

About this task

Power problems can be difficult to solve. For example, a short circuit can exist anywhere on any of the power distribution buses. Usually, a short circuit will cause the power subsystem to shut down because of an overcurrent condition. To diagnose a power problem, use the following general procedure:

Procedure

1. Turn off the server and disconnect all ac power cords.
2. Check the power-fault LEDs on the system board (see “System-board LEDs” on page 22).
3. Check the LEDs on the operator information panel (see “Operator information panel” on page 11).
4. Check for loose cables in the power subsystem. Also check for short circuits, for example, if a loose screw is causing a short circuit on a circuit board.
5. Remove the adapters and disconnect the cables and power cords to all internal and external devices until the server is at the minimum configuration that is required for the server to start (see “Power-supply LEDs” on page 319 for the minimum configuration).
6. Reconnect all ac power cords and turn on the server. If the server starts successfully, reseal the adapters and devices one at a time until the problem is isolated.

Results

If the server does not start from the minimum configuration, see “Power problems” on page 304 to replace the components in the minimum configuration one at a time until the problem is isolated.

Solving Ethernet controller problems

The method that you use to test the Ethernet controller depends on which operating system you are using. See the operating-system documentation for information about Ethernet controllers, and see the Ethernet controller device-driver readme file.

About this task

Try the following procedures:

Procedure

- Make sure that the correct device drivers, which come with the server are installed and that they are at the latest level.
- Make sure that the Ethernet cable is installed correctly.
 - The cable must be securely attached at all connections. If the cable is attached but the problem remains, try a different cable.
 - If you set the Ethernet controller to operate at 100 Mbps, you must use Category 5 cabling.

- If you directly connect two servers (without a hub), or if you are not using a hub with X ports, use a crossover cable. To determine whether a hub has an X port, check the port label. If the label contains an X, the hub has an X port.
- Determine whether the hub supports auto-negotiation. If it does not, try configuring the integrated Ethernet controller manually to match the speed and duplex mode of the hub.
- Check the Ethernet controller LEDs on the rear panel of the server. These LEDs indicate whether there is a problem with the connector, cable, or hub.
 - The Ethernet link status LED is lit when the Ethernet controller receives a link pulse from the hub. If the LED is off, there might be a defective connector or cable or a problem with the hub.
 - The Ethernet transmit/receive activity LED is lit when the Ethernet controller sends or receives data over the Ethernet network. If the Ethernet transmit/receive activity is off, make sure that the hub and network are operating and that the correct device drivers are installed.
- Check the LAN activity LED on the rear of the server. The LAN activity LED is lit when data is active on the Ethernet network. If the LAN activity LED is off, make sure that the hub and network are operating and that the correct device drivers are installed.
- Check for operating-system-specific causes of the problem.
- Make sure that the device drivers on the client and server are using the same protocol.

Results

If the Ethernet controller still cannot connect to the network but the hardware appears to be working, the network administrator must investigate other possible causes of the error.

Solving undetermined problems

If the diagnostic tests did not diagnose the failure or if the server is inoperative, use the information in this section.

About this task

If you suspect that a software problem is causing failures (continuous or intermittent), see “Software problems” on page 308.

Damaged data in CMOS memory or damaged server firmware can cause undetermined problems. To reset the CMOS data, use the CMOS jumper to clear the CMOS memory and override the power-on password; see “System-board switches and jumpers” on page 19. If you suspect that the server firmware is damaged, see “Recovering the server firmware” on page 323.

If the power supplies are working correctly, complete the following steps:

Procedure

1. Turn off the server.
2. Make sure that the server is cabled correctly.
3. Remove or disconnect the following devices, one at a time, until you find the failure. Turn on the server and reconfigure it each time.
 - Any external devices.

- Surge-suppressor device (on the server).
- Printer, mouse, and non-IBM devices.
- Each adapter.
- Hard disk drives.
- Memory modules. The minimum configuration requirement is 2 GB DIMM in slot 3.

The following minimum configuration is required to start the server:

- One microprocessor in socket 1.
- One 2 GB DIMM for each microprocessor installed (one 2 GB DIMM in slot 3 if only one microprocessor installed).
- One power supply.
- Power cords.
- Five cooling fans (fan 1, 2, 3, 4, and 5).
- One PCI riser-card assembly in PCI connector 2.
- One ServeRAID SAS/SATA controller.

4. Turn on the server.

Results

If the problem is solved when you remove an adapter from the server but the problem recurs when you reinstall the same adapter, suspect the adapter; if the problem recurs when you replace the adapter with a different one, suspect the riser card.

If you suspect a networking problem and the server passes all the system tests, suspect a network cabling problem that is external to the server.

Problem determination tips

Because of the variety of hardware and software combinations that can encounter, use the following information to assist you in problem determination. If possible, have this information available when requesting assistance from IBM.

The model number and serial number are located on the ID label on the front of the server as shown in the following illustration.

Note: The illustrations in this document might differ slightly from your hardware.

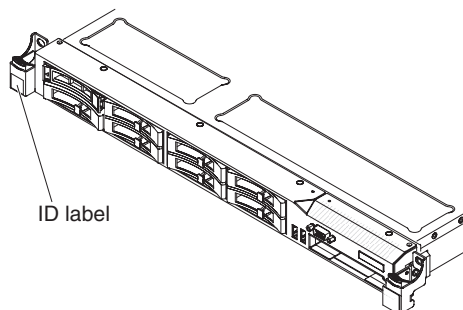

Figure 20. ID label

- Machine type and model
- Microprocessor or hard disk drive upgrades
- Failure symptom
 - Does the server fail the diagnostic tests?

- What occurs? When? Where?
- Does the failure occur on a single server or on multiple servers?
- Is the failure repeatable?
- Has this configuration ever worked?
- What changes, if any, were made before the configuration failed?
- Is this the original reported failure?
- Diagnostic program type and version level
- Hardware configuration (print screen of the system summary)
- IMM firmware level
- Operating system software

You can solve some problems by comparing the configuration and software setups between working and nonworking servers. When you compare servers to each other for diagnostic purposes, consider them identical only if all the following factors are exactly the same in all the servers:

- Machine type and model
- IMM firmware level
- Adapters and attachments, in the same locations
- Address jumpers, terminators, and cabling
- Software versions and levels
- Diagnostic program type and version level
- Configuration option settings
- Operating-system control-file setup

See “Getting help and technical assistance,” on page 483 for information about calling IBM for service.

Chapter 4. Parts listing, IBM System x3550 M3 Type 4254 and 7944

The following replaceable components are available for the IBM System x3550 M3 Type 4254 and 7944 server.

For an updated parts listing, go to <http://www.ibm.com/supportportal/>.

Replaceable server components

There are four types of replaceable components.

- **Consumables:** Purchase and replacement of consumables (components, such as batteries and printer cartridges, that have depleting life) is your responsibility. If IBM acquires or installs a consumable component at your request, you will be charged for the service.
- **Tier 1 customer replaceable unit (CRU):** Replacement of Tier 1 CRUs is your responsibility. If IBM installs a Tier 1 CRU at your request, you will be charged for the installation.
- **Tier 2 customer replaceable unit:** You may install a Tier 2 CRU yourself or request IBM to install it, at no additional charge, under the type of warranty service that is designated for your server.
- **Field replaceable unit (FRU):** FRUs must be installed only by Trained service technicians.

For information about the terms of the warranty, see the *Warranty Information* document that comes with the server.

The following illustration shows the major components in the server. The illustrations in this document might differ slightly from your hardware.

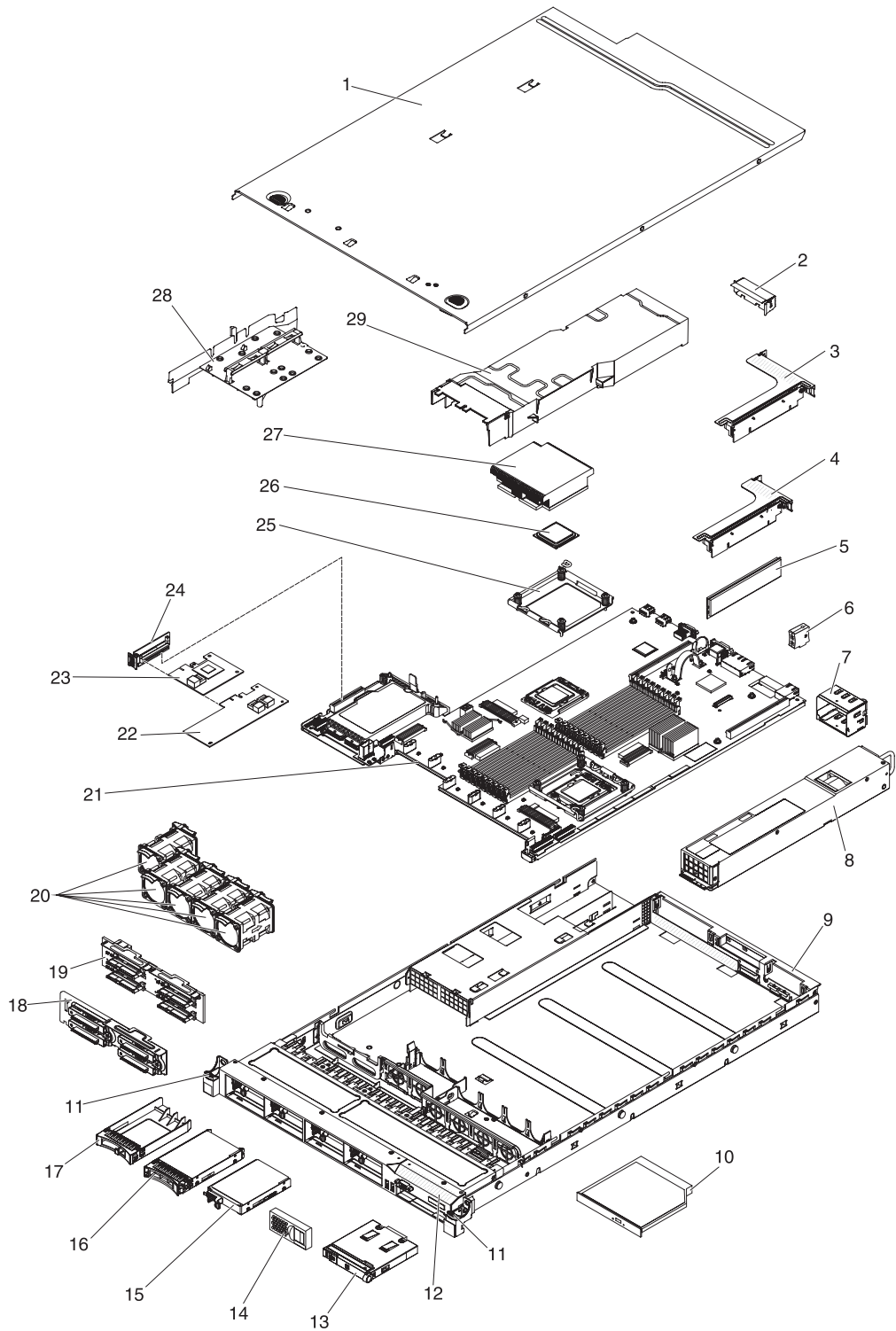

Figure 21. Server components

The following table lists the part numbers for the server components.

Table 12. Parts listing, Types 4254 and 7944

Index	Description	CRU part number (Tier 1)	CRU part number (Tier 2)	FRU part number
1	Top cover	59Y3927		
2	Filler, PCI	59Y3969		
3	PCI-X riser card		69Y4570	
4	PCI Express riser card, x16, assembly		43V7066	
5	Memory, 2 GB dual-rank DDR3 UDIMM	44T1573		
5	Memory, 4 GB dual-rank DDR3-1333 RDIMM 1.35V	49Y1412		
5	Memory, 2 GB single-rank DDR 3 RDIMM	49Y1421		
5	Memory, 4 GB dual-rank DDR3 UDIMM	49Y1422		
5	Memory, 2 GB single-rank DDR3 RDIMM	49Y1423		
5	Memory, 4 GB single-rank DDR3 RDIMM	49Y1424		
5	Memory, 4 GB dual-rank DDR3 RDIMM	49Y1425		
5	Memory, 1 GB single-rank DDR3-1333 RDIMM	49Y1442		
5	Memory, 2 GB dual-rank DDR3-1333 RDIMM	49Y1443		
5	Memory, 2 GB single-rank DDR3-1333 RDIMM	49Y1444		
5	Memory, 4 GB dual-rank DDR3-1333 RDIMM	49Y1445		
5	Memory, 8 GB dual-rank DDR3-1333 RDIMM	49Y1446		
5	Memory, 8 GB dual-rank PC3L-10600R-999 RDIMM 1.35V	49Y1415		
5	Memory, 8 GB dual-rank PC3L-8500R-777 RDIMM 1.35V	49Y1416		
5	Memory, 16 GB dual-rank PC3L-10600 DDR3-1333 RDIMM 1.35V	49Y1565		
5	Memory, 16 GB quad-rank PC3-8500R-777 RDIMM	46C7489		
6	Virtual media key	46C7528		
7	Power supply bay filler	49Y4821		
8	Power supply, 460 Watt, ac	39Y7229		
8	Power supply, 460 Watt, ac	39Y7231		
8	Power supply, 460 Watt, ac	69Y5907		
8	Power supply, 675 Watt, dc			39Y7215
8	Power supply, 675 Watt, dc			69Y5905
8	Power supply, 675 Watt HE, ac	39Y7218		
8	Power supply, 675 Watt HE, ac	69Y5901		
8	Power supply, 675 Watt HE, ac	69Y5903		
8	Power supply, 675 Watt, ac	39Y7225		
8	Power supply, 675 Watt, ac	39Y7227		
8	Power supply, 675 Watt, ac	39Y7236		
8	Power supply, 675 Watt, ac	69Y5909		
8	Power supply, 675 Watt, ac	69Y5919		
9	Chassis assembly (without front bezel)			59Y3931
10	DVD-ROM drive	44W3254		
10	DVD-RW drive	44W3256		

Table 12. Parts listing, Types 4254 and 7944 (continued)

Index	Description	CRU part number (Tier 1)	CRU part number (Tier 2)	FRU part number
11	Rack latch kit		49Y4815	
12	Bezel, 8 hard disk bays		59Y3916	
12	Bezel, 4 hard disk and 1 optical drive bays		59Y3917	
13	Operator information panel assembly		44E4372	
14	Filler, hard disk drive bay	59Y3925		
15	Hard disk drive, 2.5-inch simple-swap, 31.4 GB	43W7684		
15	Solid-state drive, 2.5-inch simple-swap SATA 256 GB	90Y8664		
15	Solid-state drive, 2.5-inch simple-swap SATA 128 GB	90Y8669		
16	Hard disk drive, 2.5-inch hot-swap, 73 GB, 10 K	43W7537		
16	Hard disk drive, 2.5-inch hot-swap, 73 GB, 15 K	43W7546		
16	Hard disk drive, 2.5-inch hot-swap, 146 GB, 10 K	43W7538		
16	Hard disk drive, 2.5-inch hot-swap, 146 GB, 15 K	42D0678		
16	Hard disk drive, 2.5-inch hot-swap, 146 GB, Slim-HS, 15 K	44W2295		
16	Hard disk drive, 2.5-inch hot-swap, 300 GB, 10 K	42D0638		
16	Hard disk drive, 2.5-inch hot-swap, 300 GB, Slim-HS, 10 K	44W2265		
16	Hard disk drive, 2.5-inch hot-swap, 500 GB, 7.2 K	42D0708		
16	Hard disk drive, 2.5-inch hot-swap, 600 GB, 10 K	49Y2004		
17	Filler, EMC	44T2248		
18	Backplate assembly, simple-swap		59Y3919	
19	Backplane, SAS		59Y3915	
20	Fan	43V6929		
21	System board			00D3283
21	System board			00D3284
22	ServeRAID-M1015 adapter	46C8933		
23	ServeRAID-BR10il v2 adapter	49Y4737		
24	SAS/SATA riser card	43V7067		
25	Retention module, heat sink			49Y4822
26	Microprocessor, Intel Xeon E5506 2.13 GHz, 4 MB, 80W (quad core)			46D1270
26	Microprocessor, Intel Xeon X5670 2.93 GHz, 12 MB, 95W (six core)			49Y7038
26	Microprocessor, Intel Xeon X5650 2.66 GHz, 12 MB, 95W (six core)			49Y7040
26	Microprocessor, Intel Xeon E5640 2.66 GHz, 12 MB, 80W (quad core)			49Y7051
26	Microprocessor, Intel Xeon E5630 2.53 GHz, 12 MB, 80W (quad core)			49Y7052
26	Microprocessor, Intel Xeon E5620 2.40 GHz, 12 MB, 80W (quad core)			49Y7053
26	Microprocessor, Intel Xeon L5640 2.26 GHz, 12 MB, 60W (six core)			49Y7054

Table 12. Parts listing, Types 4254 and 7944 (continued)

Index	Description	CRU part number (Tier 1)	CRU part number (Tier 2)	FRU part number
26	Microprocessor, Intel Xeon L5630 2.13 GHz, 12 MB, 40W (quad core)			59Y3691
26	Microprocessor, Intel Xeon E5507 2.26 GHz, 4 MB, 80W (quad core)			69Y0782
26	Microprocessor, Intel Xeon L5609 1.86 GHz, 12 MB, 40W (quad core)			69Y0783
26	Microprocessor, Intel Xeon X5680 3.33 GHz, 12 MB, 130W (six core)			69Y0849
26	Microprocessor, Intel Xeon E5645 2.40 GHz, 12 MB, 80W (six core)			69Y4714
26	Microprocessor, Intel Xeon E5603 1.60 GHz, 4 MB, 80W (quad core)			81Y5952
26	Microprocessor, Intel Xeon E5606 2.13 GHz, 8 MB, 80W (quad core)			81Y5953
26	Microprocessor, Intel Xeon E5607 2.26 GHz, 8 MB, 80W (quad core)			81Y5954
26	Microprocessor, Intel Xeon E5649 2.53 GHz, 12 MB, 80W (six core)			81Y5955
26	Microprocessor, Intel Xeon X5647 2.93 GHz, 12 MB, 130W (quad core)			81Y5956
26	Microprocessor, Intel Xeon X5672 3.20 GHz, 12 MB, 95W (quad core)			81Y5957
26	Microprocessor, Intel Xeon X5675 3.06GHz, 12MB, 95W (six core)			81Y5958
26	Microprocessor, Intel Xeon X5687 3.60 GHz, 12 MB, 130W (quad core)			81Y5959
26	Microprocessor, Intel Xeon X5690 3.46GHz, 12 MB, 130W (six core)			81Y5960
27	Heat sink assembly			49Y4820
27	Heat sink assembly, 130W			69Y1207
28	Air baffle kit (Microprocessor air baffle, clamp, and DIMM air duct)	59Y3914		
	Battery, 3.0 volt	33F8354		
	Cable, hard disk drive configuration		59Y3918	
	Cable, operator panel		46C4139	
	Cable, SAS power		59Y3920	
	Cable, SAS signal, 300 mm		49Y4850	
	Cable, SAS signal, 450 mm		59Y3921	
	Cable, SAS signal, 710 mm		69Y1328	
	Cable, SATA DVD		59Y3922	
	Cable, USB/video		59Y3923	
	Cable, line cord	39M5377		
	Cage, hard disk drive		59Y3968	

Table 12. Parts listing, Types 4254 and 7944 (continued)

Index	Description	CRU part number (Tier 1)	CRU part number (Tier 2)	FRU part number
	Cage, optical drive		59Y3924	
	CPU extraction tool			81Y9398
	Safety cover			49Y4823
	Filler, DVD drive bay	49Y4868		
	2-port 1 Gb Ethernet card	69Y4509		
	2-port 1 Gb Ethernet card, mechanical kit	69Y4586		
	Labels, chassis	59Y3998		
	Labels, system service	59Y3926		
	Riser-card bracket: full-height, half-length		43V6936	
	Riser-card bracket: low-profile		43V6939	
	Bracket assembly, rear I/O			43V6938
	SAS adapter retainer		49Y4852	
	ServeRAID-MR10i adapter		46C9037	
	ServeRAID-MR10i battery carrier kit		46C9041	
	ServeRAID-BR10i adapter	46C9043		
	ServeRAID-B5015 solid-state-drive (SSD) adapter	46M0970		
	ServeRAID-M5014 adapter	46C8929		
	ServeRAID-M5015 adapter	46C8927		
	ServeRAID-M5016 adapter	46C8974		
	ServeRAID-M5000 advanced feature key	46M0931		
	ServeRAID-M5000 series battery kit	81Y4451		
	ServeRAID-M5100 series flash power module	81Y4579		
	Cable, ServeRAID battery (with interposer card)		44E8844	
	Cable, ServeRAID-M5100 series flash power module	90Y7310		
	PRO/1000 PT quad-port adapter	39Y6138		
	NetXtreme II 1000 Express quad port Ethernet adapter	49Y4222		
	QLogic 10Gb SFP+ SR optical transceiver	42C1816		
	QLogic 10Gb CNA for IBM System x	00Y3274		
	Brocade 10Gb SFP+ SR optical transceiver	46C9297		
	Brocade 10Gb CNA for IBM System x	42C1822		
	Video adapter, NVIDIA FX 1700	43V5765		
	Video adapter, NVIDIA FX 570	43V5782		
	Video adapter, NVIDIA FX 580	43V5890		
	Slide rail kit		59Y3792	
	Slide rail kit		69Y5085	
	CMA kit	49Y4817		
	Slide rail kit, Gen-II		69Y4391	
	CMA kit, Gen-II	69Y4392		

Table 12. Parts listing, Types 4254 and 7944 (continued)

Index	Description	CRU part number (Tier 1)	CRU part number (Tier 2)	FRU part number
	Miscellaneous parts kit		69Y5639	
	Screw kit	59Y4922		
	Thermal grease kit		41Y9292	
	Hypervisor, embedded USB flash device	42D0545		
	Alcohol wipes		59P4739	

Consumable parts

Consumable parts are not covered by the IBM Statement of Limited Warranty. The following consumable parts are available for purchase from the retail store.

Table 13. Consumable parts, Types 4254 and 7944

Index	Description	Part number
	ServeRAID-MR10i battery	46C9040
	Cable clip, ServeRAID-M5016 SAS/SATA controller	00D3956

To order a consumable part, complete the following steps:

1. Go to <http://www.ibm.com>.
2. From the **Products** menu, select **Upgrades, accessories & parts**.
3. Click **Obtain maintenance parts**; then, follow the instructions to order the part from the retail store.

If you need help with your order, call the toll-free number that is listed on the retail parts page, or contact your local IBM representative for assistance.

Product recovery CDs

The following table describes the product recovery CD CRUs.

Table 14. Product recovery CDs, Type 7944

Description	CRU part number
VMware ESX Server 3i Version 3.5	46D0762
VMware ESX Server 3i Version 3.5 Update 2	46M9236
VMware ESX Server 3i Version 3.5 Update 3	46M9237
VMware ESX Server 3i Version 3.5 Update 4	46M9238
VMware ESX Server 3i Version 3.5 Update 5	68Y9633
VMware ESXi 4.0	49Y8747
VMware ESXi 4.0 Update 1	68Y9634
VMware ESXi 4.1	81Y2028
VMware vSphere ESXi 4.1 (without Flash memory USB key)	81Y2028
VMware vSphere ESXi 4.1 Update 1 (without Flash memory USB key)	95Y3065
Microsoft Windows 2008 DataCenter 32b/64b, Multilingual	49Y0222

Table 14. Product recovery CDs, Type 7944 (continued)

Description	CRU part number
Microsoft Windows 2008 Datacenter SP2 32b/64b, Multilingual	60Y1760
Microsoft Windows 2008 Datacenter 32b/64b, Simplified Chinese	49Y0223
Microsoft Windows 2008 Datacenter 32b/64b, Traditional Chinese	49Y0224
Microsoft Windows 2008 R2 Datacenter, Multilingual	59Y7332
Microsoft Windows 2008 R2 Datacenter, Simplified Chinese	59Y7333
Microsoft Windows 2008 R2 Datacenter, Traditional Chinese	59Y7334
Microsoft Windows HPC Server 2008, 1-4 Processors, English	68Y9455
Microsoft Windows HPC Server 2008, 1-4 Processors, Japanese	68Y9456
Microsoft Windows HPC Server 2008, 1-4 Processors, Simplified Chinese	68Y9457
Microsoft Windows 2008 Server Standard Edition 32b/64b, 1-4 Processors, Multilingual	49Y0892
Microsoft Windows 2008 Server Standard Edition 32b/64b, 1-4 Processors, Simplified Chinese	49Y0893
Microsoft Windows 2008 Server Standard Edition 32b/64b, 1-4 Processors, Traditional Chinese	49Y0894
Microsoft Windows 2008 Enterprise Edition 32b/64b, 1-8 Processors, Multilingual	49Y0895
Microsoft Windows 2008 Enterprise Edition 32b/64b, 1-8 Processors, Simplified Chinese	49Y0896
Microsoft Windows 2008 Enterprise Edition 32b/64b, 1-8 Processors, Traditional Chinese	49Y0897
Microsoft Windows Server 2008 R2 Foundation Edition, English	81Y2001
Microsoft Windows Server 2008 R2 Foundation Edition, French	81Y2002
Microsoft Windows Server 2008 R2 Foundation Edition, German	81Y2003
Microsoft Windows Server 2008 R2 Foundation Edition, Spanish	81Y2004
Microsoft Windows Server 2008 R2 Foundation Edition, Italian	81Y2005
Microsoft Windows Server 2008 R2 Foundation Edition, Brazilian	81Y2006
Microsoft Windows Server 2008 R2 Foundation Edition, Polish	81Y2007
Microsoft Windows Server 2008 R2 Foundation Edition, Russian	81Y2008
Microsoft Windows Server 2008 R2 Foundation Edition, Turkish	81Y2009
Microsoft Windows Server 2008 R2 Foundation Edition, Japanese	81Y2010
Microsoft Windows Server 2008 R2 Foundation Edition, Simplified Chinese	81Y2011
Microsoft Windows Server 2008 R2 Foundation Edition, Traditional Chinese	81Y2012

Table 14. Product recovery CDs, Type 7944 (continued)

Description	CRU part number
Microsoft Windows Server 2008 R2 Foundation Edition, Korean	81Y2013
Microsoft Windows Server 2008 R2 Foundation Edition, Czech	81Y2014
Microsoft Windows Server 2008 R2 Standard Edition, Multilingual	81Y2015
Microsoft Windows Server 2008 R2 Standard Edition, Simplified Chinese	81Y2016
Microsoft Windows Server 2008 R2 Standard Edition, Traditional Chinese	81Y2017
Microsoft Windows Server 2008 R2 Enterprise Edition, Multilingual	81Y2018
Microsoft Windows Server 2008 R2 Enterprise Edition, Simplified Chinese	81Y2019
Microsoft Windows Server 2008 R2 Enterprise Edition, Traditional Chinese	81Y2020
Microsoft Windows Server 2008 R2 Enterprise Edition, 10 CALs, Multilingual	81Y2021
Microsoft Windows Server 2008 R2 Enterprise Edition, 10 CALs, Simplified Chinese	81Y2022
Microsoft Windows Server 2008 R2 Enterprise Edition, 10 CALs, Traditional Chinese	81Y2023
Microsoft Windows Server 2008 R2 Datacenter Edition Service Pack 1, Multilingual	88Y7794
Microsoft Windows Server 2008 R2 Datacenter Edition Service Pack 1, Czech	88Y7795
Microsoft Windows Server 2008 R2 Datacenter Edition Service Pack 1, Traditional Chinese	88Y7796
Microsoft Windows Server 2008 R2 Foundation Edition Service Pack 1, English	95Y3009
Microsoft Windows Server 2008 R2 Foundation Edition Service Pack 1, French	95Y3010
Microsoft Windows Server 2008 R2 Foundation Edition Service Pack 1, German	95Y3011
Microsoft Windows Server 2008 R2 Foundation Edition Service Pack 1, Spanish	95Y3012
Microsoft Windows Server 2008 R2 Foundation Edition Service Pack 1, Italian	95Y3013
Microsoft Windows Server 2008 R2 Foundation Edition Service Pack 1, Brazilian	95Y3014
Microsoft Windows Server 2008 R2 Foundation Edition Service Pack 1, Polish	95Y3015
Microsoft Windows Server 2008 R2 Foundation Edition Service Pack 1, Russian	95Y3016
Microsoft Windows Server 2008 R2 Foundation Edition Service Pack 1, Turkish	95Y3017
Microsoft Windows Server 2008 R2 Foundation Edition Service Pack 1, Japanese	95Y3018

Table 14. Product recovery CDs, Type 7944 (continued)

Description	CRU part number
Microsoft Windows Server 2008 R2 Foundation Edition Service Pack 1, Simplified Chinese	95Y3020
Microsoft Windows Server 2008 R2 Foundation Edition Service Pack 1, Traditional Chinese	95Y3021
Microsoft Windows Server 2008 R2 Foundation Edition Service Pack 1, Korean	95Y3022
Microsoft Windows Server 2008 R2 Foundation Edition Service Pack 1, Czech	95Y3023
Microsoft Windows Server 2008 R2 Enterprise Edition Service Pack 1, Multilingual	95Y3024
Microsoft Windows Server 2008 R2 Enterprise Edition Service Pack 1, Simplified Chinese	95Y3025
Microsoft Windows Server 2008 R2 Enterprise Edition Service Pack 1, Traditional Chinese	95Y3026
Microsoft Windows Server 2008 R2 Standard Edition Service Pack 1, Multilingual	95Y3027
Microsoft Windows Server 2008 R2 Standard Edition Service Pack 1, Simplified Chinese	95Y3028
Microsoft Windows Server 2008 R2 Standard Edition Service Pack 1, Traditional Chinese	95Y3029
Microsoft Windows Server 2008 R2 Standard Edition, Multilingual	95Y3213
Microsoft Windows Server 2008 R2 Enterprise Edition, Multilingual	95Y3214
Microsoft Windows Server 2012 Standard/Datacenter Edition, Brazilian Portuguese	47C8611
Microsoft Windows Server 2012 Standard/Datacenter Edition, Simplified Chinese	47C8612
Microsoft Windows Server 2012 Standard/Datacenter Edition, Traditional Chinese	47C8613
Microsoft Windows Server 2012 Standard/Datacenter Edition, Czech	47C8614
Microsoft Windows Server 2012 Standard/Datacenter Edition, English	47C8615
Microsoft Windows Server 2012 Standard/Datacenter Edition, French	47C8616
Microsoft Windows Server 2012 Standard/Datacenter Edition, German	47C8617
Microsoft Windows Server 2012 Standard/Datacenter Edition, Italian	47C8618
Microsoft Windows Server 2012 Standard/Datacenter Edition, Japanese	47C8619
Microsoft Windows Server 2012 Standard/Datacenter Edition, Korean	47C8620
Microsoft Windows Server 2012 Standard/Datacenter Edition, Polish	47C8621

Table 14. Product recovery CDs, Type 7944 (continued)

Description	CRU part number
Microsoft Windows Server 2012 Standard/Datacenter Edition, Russian	47C8622
Microsoft Windows Server 2012 Standard/Datacenter Edition, Spanish	47C8623
Microsoft Windows Server 2012 Standard/Datacenter Edition, Swedish	47C8624
Microsoft Windows Server 2012 Standard/Datacenter Edition, Turkish	47C8625
Microsoft Windows Server 2012 Foundation Edition, Brazilian Portuguese	47C8626
Microsoft Windows Server 2012 Foundation Edition, Simplified Chinese	47C8627
Microsoft Windows Server 2012 Foundation Edition, Traditional Chinese	47C8628
Microsoft Windows Server 2012 Foundation Edition, Czech	47C8629
Microsoft Windows Server 2012 Foundation Edition, English	47C8630
Microsoft Windows Server 2012 Foundation Edition, French	47C8631
Microsoft Windows Server 2012 Foundation Edition, German	47C8632
Microsoft Windows Server 2012 Foundation Edition, Italian	47C8633
Microsoft Windows Server 2012 Foundation Edition, Japanese	47C8634
Microsoft Windows Server 2012 Foundation Edition, Korean	47C8635
Microsoft Windows Server 2012 Foundation Edition, Polish	47C8636
Microsoft Windows Server 2012 Foundation Edition, Russian	47C8637
Microsoft Windows Server 2012 Foundation Edition, Spanish	47C8638
Microsoft Windows Server 2012 Foundation Edition, Swedish	47C8639
Microsoft Windows Server 2012 Foundation Edition, Turkish	47C8640
Microsoft Windows Storage Server 2012, Brazilian Portuguese	47C8641
Microsoft Windows Storage Server 2012, Simplified Chinese	47C8642
Microsoft Windows Storage Server 2012, Traditional Chinese	47C8643
Microsoft Windows Storage Server 2012, Czech	47C8644
Microsoft Windows Storage Server 2012, English	47C8645
Microsoft Windows Storage Server 2012, French	47C8646
Microsoft Windows Storage Server 2012, Germany	47C8647
Microsoft Windows Storage Server 2012, Italian	47C8648
Microsoft Windows Storage Server 2012, Japanese	47C8649
Microsoft Windows Storage Server 2012, Korean	47C8650
Microsoft Windows Storage Server 2012, Polish	47C8651
Microsoft Windows Storage Server 2012, Russian	47C8652
Microsoft Windows Storage Server 2012, Spanish	47C8653
Microsoft Windows Storage Server 2012, Swedish	47C8654
Microsoft Windows Storage Server 2012, Turkish	47C8655

Table 14. Product recovery CDs, Type 7944 (continued)

Description	CRU part number
Microsoft Windows Server 2012 Essentials Edition, Brazilian Portuguese	47C9384
Microsoft Windows Server 2012 Essentials Edition, Simplified Chinese	47C9385
Microsoft Windows Server 2012 Essentials Edition, Traditional Chinese	47C9386
Microsoft Windows Server 2012 Essentials Edition, Czech	47C9387
Microsoft Windows Server 2012 Essentials Edition, English	47C9388
Microsoft Windows Server 2012 Essentials Edition, French	47C9389
Microsoft Windows Server 2012 Essentials Edition, German	47C9390
Microsoft Windows Server 2012 Essentials Edition, Italian	47C9391
Microsoft Windows Server 2012 Essentials Edition, Japanese	47C9392
Microsoft Windows Server 2012 Essentials Edition, Korean	47C9393
Microsoft Windows Server 2012 Essentials Edition, Polish	47C9394
Microsoft Windows Server 2012 Essentials Edition, Russian	47C9395
Microsoft Windows Server 2012 Essentials Edition, Spanish	47C9396
Microsoft Windows Server 2012 Essentials Edition, Swedish	47C9397
Microsoft Windows Server 2012 Essentials Edition, Turkish	47C9398

Power cords

For your safety, a power cord with a grounded attachment plug is provided to use with this product. To avoid electrical shock, always use the power cord and plug with a properly grounded outlet.

IBM power cords used in the United States and Canada are listed by Underwriter's Laboratories (UL) and certified by the Canadian Standards Association (CSA).

For units intended to be operated at 115 volts: Use a UL-listed and CSA-certified cord set consisting of a minimum 18 AWG, Type SVT or SJT, three-conductor cord, a maximum of 15 feet in length and a parallel blade, grounding-type attachment plug rated 15 amperes, 125 volts.

For units intended to be operated at 230 volts (U.S.): Use a UL-listed and CSA-certified cord set consisting of a minimum 18 AWG, Type SVT or SJT, three-conductor cord, a maximum of 15 feet in length and a tandem blade, grounding-type attachment plug rated 15 amperes, 250 volts.

For units intended to be operated at 230 volts (outside the U.S.): Use a cord set with a grounding-type attachment plug. The cord set should have the appropriate safety approvals for the country in which the equipment will be installed.

IBM power cords for a specific country or region are usually available only in that country or region.

IBM power cord part number	Used in these countries and regions
39M5206	China
39M5102	Australia, Fiji, Kiribati, Nauru, New Zealand, Papua New Guinea
39M5123	Afghanistan, Albania, Algeria, Andorra, Angola, Armenia, Austria, Azerbaijan, Belarus, Belgium, Benin, Bosnia and Herzegovina, Bulgaria, Burkina Faso, Burundi, Cambodia, Cameroon, Cape Verde, Central African Republic, Chad, Comoros, Congo (Democratic Republic of), Congo (Republic of), Cote D'Ivoire (Ivory Coast), Croatia (Republic of), Czech Republic, Dahomey, Djibouti, Egypt, Equatorial Guinea, Eritrea, Estonia, Ethiopia, Finland, France, French Guyana, French Polynesia, Germany, Greece, Guadeloupe, Guinea, Guinea Bissau, Hungary, Iceland, Indonesia, Iran, Kazakhstan, Kyrgyzstan, Laos (People's Democratic Republic of), Latvia, Lebanon, Lithuania, Luxembourg, Macedonia (former Yugoslav Republic of), Madagascar, Mali, Martinique, Mauritania, Mauritius, Mayotte, Moldova (Republic of), Monaco, Mongolia, Morocco, Mozambique, Netherlands, New Caledonia, Niger, Norway, Poland, Portugal, Reunion, Romania, Russian Federation, Rwanda, Sao Tome and Principe, Saudi Arabia, Senegal, Serbia, Slovakia, Slovenia (Republic of), Somalia, Spain, Suriname, Sweden, Syrian Arab Republic, Tajikistan, Tahiti, Togo, Tunisia, Turkey, Turkmenistan, Ukraine, Upper Volta, Uzbekistan, Vanuatu, Vietnam, Wallis and Futuna, Yugoslavia (Federal Republic of), Zaire
39M5130	Denmark
39M5144	Bangladesh, Lesotho, Macao, Maldives, Namibia, Nepal, Pakistan, Samoa, South Africa, Sri Lanka, Swaziland, Uganda
39M5151	Abu Dhabi, Bahrain, Botswana, Brunei Darussalam, Channel Islands, China (Hong Kong S.A.R.), Cyprus, Dominica, Gambia, Ghana, Grenada, Iraq, Ireland, Jordan, Kenya, Kuwait, Liberia, Malawi, Malaysia, Malta, Myanmar (Burma), Nigeria, Oman, Polynesia, Qatar, Saint Kitts and Nevis, Saint Lucia, Saint Vincent and the Grenadines, Seychelles, Sierra Leone, Singapore, Sudan, Tanzania (United Republic of), Trinidad and Tobago, United Arab Emirates (Dubai), United Kingdom, Yemen, Zambia, Zimbabwe
39M5158	Liechtenstein, Switzerland
39M5165	Chile, Italy, Libyan Arab Jamahiriya
39M5172	Israel
39M5095	220 - 240 V Antigua and Barbuda, Aruba, Bahamas, Barbados, Belize, Bermuda, Bolivia, Caicos Islands, Canada, Cayman Islands, Colombia, Costa Rica, Cuba, Dominican Republic, Ecuador, El Salvador, Guam, Guatemala, Haiti, Honduras, Jamaica, Mexico, Micronesia (Federal States of), Netherlands Antilles, Nicaragua, Panama, Peru, Philippines, Saudi Arabia, Thailand, Taiwan, United States of America, Venezuela

IBM power cord part number	Used in these countries and regions
39M5081	110 - 120 V Antigua and Barbuda, Aruba, Bahamas, Barbados, Belize, Bermuda, Bolivia, Caicos Islands, Canada, Cayman Islands, Colombia, Costa Rica, Cuba, Dominican Republic, Ecuador, El Salvador, Guam, Guatemala, Haiti, Honduras, Jamaica, Mexico, Micronesia (Federal States of), Netherlands Antilles, Nicaragua, Panama, Peru, Philippines, Saudi Arabia, Thailand, Taiwan, United States of America, Venezuela
39M5219	Korea (Democratic People's Republic of), Korea (Republic of)
39M5199	Japan
39M5068	Argentina, Paraguay, Uruguay
39M5226	India
39M5240	Brazil

Chapter 5. Removing and replacing components

There are four types of replaceable components.

- **Consumables:** Purchase and replacement of consumables (components, such as batteries and printer cartridges, that have depleting life) is your responsibility. If IBM acquires or installs a consumable component at your request, you will be charged for the service.
- **Tier 1 customer replaceable unit (CRU):** Replacement of Tier 1 CRUs is your responsibility. If IBM installs a Tier 1 CRU at your request, you will be charged for the installation.
- **Tier 2 customer replaceable unit:** You may install a Tier 2 CRU yourself or request IBM to install it, at no additional charge, under the type of warranty service that is designated for your server.
- **Field replaceable unit (FRU):** FRUs must be installed only by trained service technicians.

See Chapter 4, “Parts listing, IBM System x3550 M3 Type 4254 and 7944,” on page 333 to determine whether a component is a Tier 1 CRU, Tier 2 CRU, or FRU.

For information about the terms of the warranty, see the *Warranty Information* document that comes with the server.

For more information about getting service and assistance, see “Getting help and technical assistance,” on page 483.

Installation guidelines

Use this information for installation.

Attention: Static electricity that is released to internal server components when the server is powered-on might cause the system to halt, which might result in the loss of data. To avoid this potential problem, always use an electrostatic-discharge wrist strap or other grounding system when removing or installing a hot-swap device.

Before you install optional devices, read the following information:

- Read the safety information in “Safety” on page vii, the guidelines in “Working inside the server with the power on” on page 349, and “Handling static-sensitive devices” on page 350. This information will help you work safely.
- Make sure that the devices that you are installing are supported. For a list of supported optional devices for the server, see <http://www.ibm.com/systems/info/x86servers/serverproven/compat/us/>.
- When you install your new server, take the opportunity to download and apply the most recent firmware updates. This step will help to ensure that any known issues are addressed and that your server is ready to function at maximum levels of performance. To download firmware updates for your server, go to <http://www.ibm.com/support/fixcentral/>.

Important: Some cluster solutions require specific code levels or coordinated code updates. If the device is part of a cluster solution, verify that the latest level of code is supported for the cluster solution before you update the code.

For additional information about tools for updating, managing, and deploying firmware, see the ToolsCenter for System x and BladeCenter at <http://publib.boulder.ibm.com/infocenter/toolsctr/v1r0/>.

- Before you install optional hardware, make sure that the server is working correctly. Start the server, and make sure that the operating system starts, if an operating system is installed, or that a 19990305 error code is displayed, indicating that an operating system was not found but the server is otherwise working correctly. If the server is not working correctly, see the *Problem Determination and Service Guide* on the IBM System x Documentation CD for diagnostic information.
- Observe good housekeeping in the area where you are working. Place removed covers and other parts in a safe place.
- If you must start the server while the server cover is removed, make sure that no one is near the server and that no tools or other objects have been left inside the server.
- Do not attempt to lift an object that you think is too heavy for you. If you have to lift a heavy object, observe the following precautions:
 - Make sure that you can stand safely without slipping.
 - Distribute the weight of the object equally between your feet.
 - Use a slow lifting force. Never move suddenly or twist when you lift a heavy object.
 - To avoid straining the muscles in your back, lift by standing or by pushing up with your leg muscles.
- Make sure that you have an adequate number of properly grounded electrical outlets for the server, monitor, and other devices.
- Back up all important data before you make changes to disk drives.
- Have a small flat-blade screwdriver, a small Phillips screwdriver, and a T8 torx screwdriver available.
- You do not have to turn off the server to install or replace hot-swap power supplies, hot-swap fans, or hot-plug Universal Serial Bus (USB) devices. However, you must turn off the server before you perform any steps that involve removing or installing adapter cables and you must disconnect the power source from the server before you perform any steps that involve removing or installing a riser card.
- Blue on a component indicates touch points, where you can grip the component to remove it from or install it in the server, open or close a latch, and so on.
- Orange on a component or an orange label on or near a component indicates that the component can be hot-swapped, which means that if the server and operating system support hot-swap capability, you can remove or install the component while the server is running. (Orange can also indicate touch points on hot-swap components.) See the instructions for removing or installing a specific hot-swap component for any additional procedures that you might have to perform before you remove or install the component.
- When you are finished working on the server, reinstall all safety shields, guards, labels, and ground wires.

System reliability guidelines

To help ensure proper system cooling and system reliability, make sure that the following requirements are met.

To help ensure proper system cooling and system reliability, make sure that the following requirements are met:

- Each of the drive bays has a drive or a filler panel and electromagnetic compatibility (EMC) shield installed in it.
- If the server has redundant power, each of the power-supply bays has a power supply installed in it.
- There is adequate space around the server to allow the server cooling system to work properly. Leave approximately 50 mm (2.0 in.) of open space around the front and rear of the server. Do not place objects in front of the fans. For proper cooling and airflow, replace the server cover before you turn on the server.
- You have followed the cabling instructions that come with optional adapters.
- You have replaced a failed fan within 48 hours.
- You have replaced a hot-swap fan within 30 seconds of removal.
- You have replaced a hot-swap drive within 2 minutes of removal.
- You do not operate the server without the air baffle installed. Operating the server without the air baffle might cause the microprocessor to overheat.
- Microprocessor socket 2 always contains either a microprocessor baffle or a microprocessor and heat sink.
- You have installed the sixth fan when you installed the second microprocessor option.

Working inside the server with the power on

Use this information when working inside the server with the power on.

Attention: Static electricity that is released to internal server components when the server is powered-on might cause the server to halt, which might result in the loss of data. To avoid this potential problem, always use an electrostatic-discharge wrist strap or other grounding system when you work inside the server with the power on.

The server supports hot-plug, hot-add, and hot-swap devices and is designed to operate safely while it is turned on and the server cover is removed. Follow these guidelines when you work inside a server that is turned on:

- Avoid wearing loose-fitting clothing on your forearms. Button long-sleeved shirts before working inside the server; do not wear cuff links while you are working inside the server.
- Do not allow your necktie or scarf to hang inside the server.
- Remove jewelry, such as bracelets, necklaces, rings, and loose-fitting wrist watches.
- Remove items from your shirt pocket, such as pens and pencils, that could fall into the server as you lean over it.
- Avoid dropping any metallic objects, such as paper clips, hairpins, and screws, into the server.

Handling static-sensitive devices

Use this information to handle static-sensitive devices.

Attention: Static electricity can damage the server and other electronic devices. To avoid damage, keep static-sensitive devices in their static-protective packages until you are ready to install them.

To reduce the possibility of damage from electrostatic discharge, observe the following precautions:

- Limit your movement. Movement can cause static electricity to build up around you.
- The use of a grounding system is recommended. For example, wear an electrostatic-discharge wrist strap, if one is available. Always use an electrostatic-discharge wrist strap or other grounding system when working inside the server with the power on.
- Handle the device carefully, holding it by its edges or its frame.
- Do not touch solder joints, pins, or exposed circuitry.
- Do not leave the device where others can handle and damage it.
- While the device is still in its static-protective package, touch it to an unpainted metal surface on the outside of the server for at least 2 seconds. This drains static electricity from the package and from your body.
- Remove the device from its package and install it directly into the server without setting down the device. If it is necessary to set down the device, put it back into its static-protective package. Do not place the device on the server cover or on a metal surface.
- Take additional care when handling devices during cold weather. Heating reduces indoor humidity and increases static electricity.

Returning a device or component

If you are instructed to return a device or component, follow all packaging instructions, and use any packaging materials for shipping that are supplied to you.

Internal cable routing and connectors

Use this information to view the cable connection and connectors.

The following illustration shows the internal routing and connectors for the two SAS signal cables (in server models with eight drive bays).

Notes:

1. To connect the SAS signal cables, make sure that you first connect the signal cable, and then the power cable and configuration cable.
2. To disconnect the SAS signal cables, make sure that you first disconnect the power cable, and then the signal cable and configuration cable.

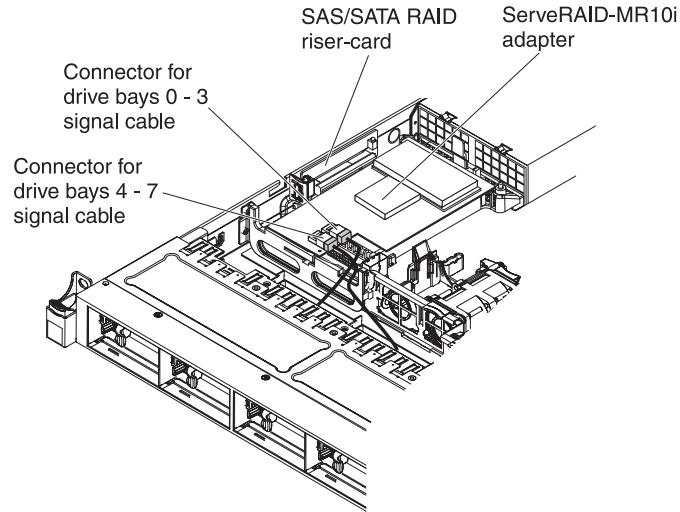

Figure 22. ServeRAID adapter cable connection

The following illustration shows the internal routing and connector for the optional optical drive cable.

Attention: To disconnect the optional optical drive cable, you must first press the connector release tab, and then disconnect the cable from the connector on the system board. Do not disconnect the cable by using excessive force.

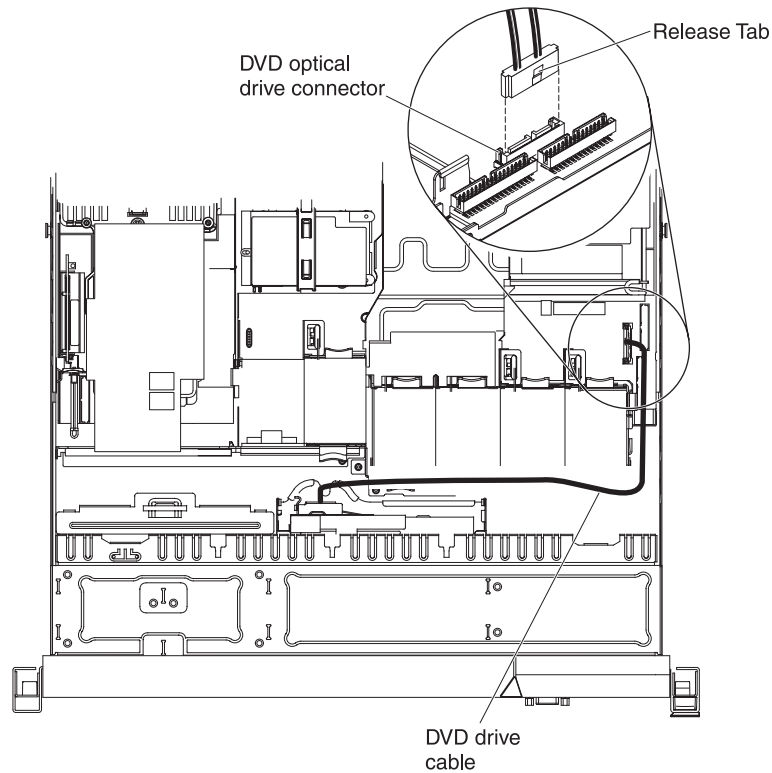

Figure 23. DVD drive cable connection

The following illustration shows the internal routing and connector for the operator information panel cable. The following notes describe additional information you must consider when you install or remove the operator information panel cable:

- You may remove the optional optical drive cable to obtain more room before you install or remove the operator information panel cable.
- To remove the operator information panel cable, slightly press the cable toward the chassis; then, pull to remove the cable from the connector on the system board. Pulling the cable out of the connector by excessive force might cause damage to the cable or connector.
- To connect the operator information panel cable on the system board, press evenly on the cable. Pressing on one side of the cable might cause damage to the cable or connector.

Attention: Failing to install or remove the cable with care may damage the connectors on the system board. Any damage to the connectors may require replacing the system board.

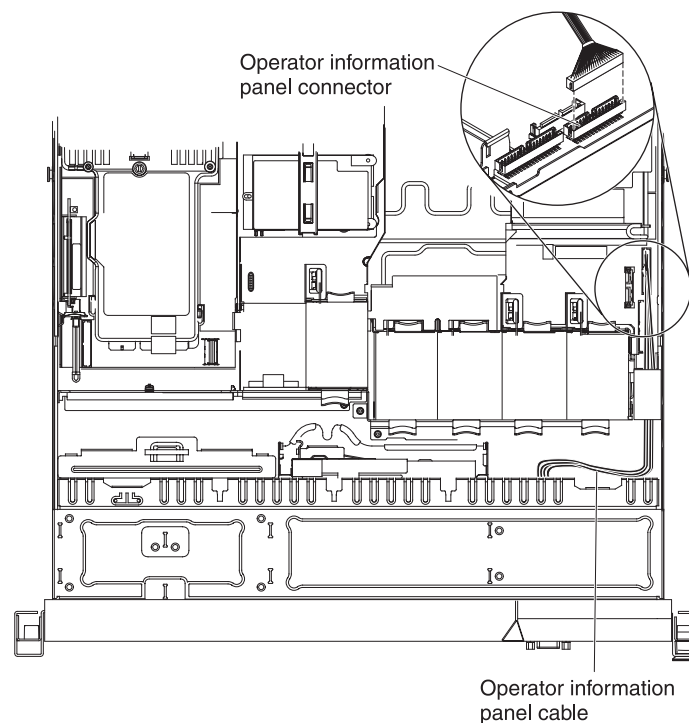

Figure 24. Operator information panel cable connection

The following illustration shows the internal routing and connector for the USB/video cable. The following notes describes other information you must consider when you install or remove the USB/video cable:

- You may remove the optional optical drive cable to obtain more room before you install or remove the operator information panel cable.
- The USB/video cable is routed under the video cable and then both the USB and video cables are routed under the cable retention tab and the top cover latch receptacle.

- To remove the USB/video cable, slightly press the cable toward the chassis; then, pull to remove the cable from the connector on the system board. Pulling the cable out of the connector by excessive force might cause damage to the cable or connector.
- To connect the USB/video cable on the system board, press evenly on the cable. Pressing on one side of the cable might cause damage to the cable or connector.

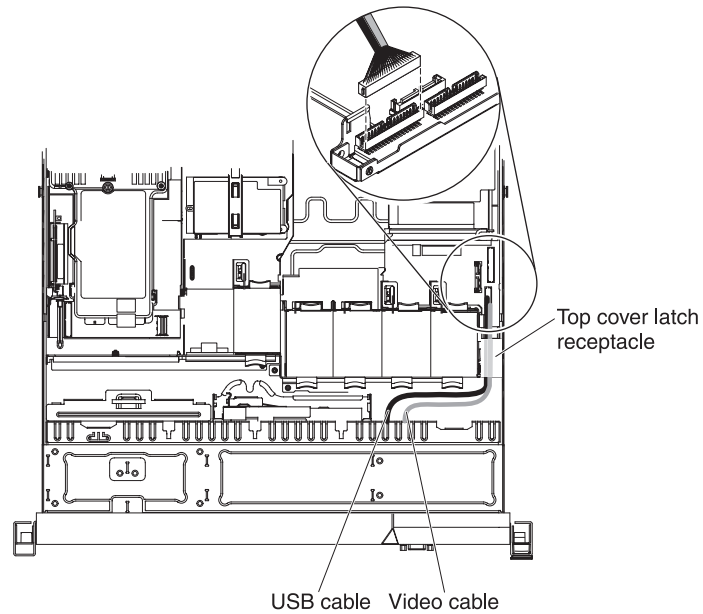

Figure 25. USB/video cable connection

The following illustration shows the internal routing for the SATA power cable and signal cable.

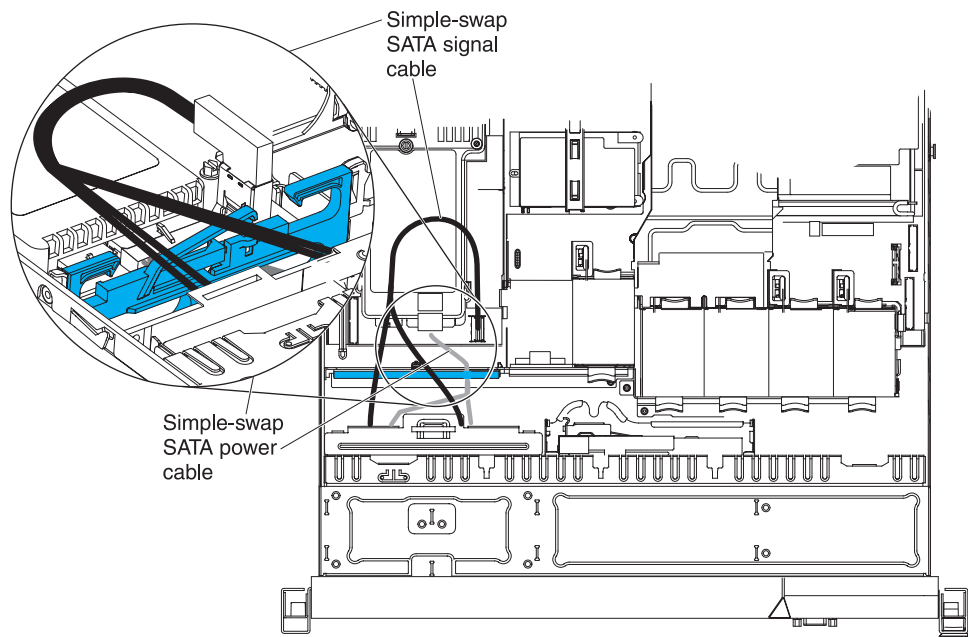

Figure 26. Simple-swap backplate assembly cable connection

The following illustration shows the internal routing for the SATA power cable, the SATA signal cable, and the configuration cable.

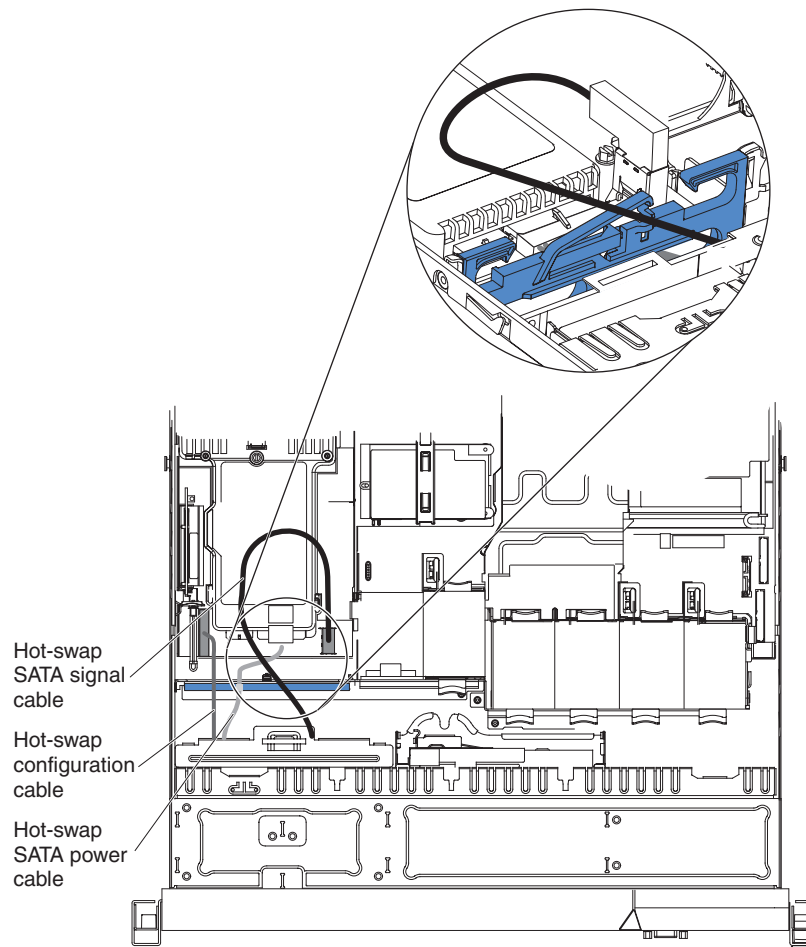

Figure 27. Hot-swap backplane cable connection

Removing and replacing consumable parts and Tier 1 CRUs

Replacement of consumable parts and Tier 1 CRUs is your responsibility. If IBM installs a consumable part or Tier 1 CRU at your request, you will be charged for the installation.

Note: The illustrations in this document might differ slightly from your hardware.

Removing the cover

Use this information to remove the cover.

About this task

To remove the server cover, complete the following steps:

Procedure

1. Read the safety information that begins on “Safety” on page vii and “Installation guidelines” on page 347.
2. Turn off the server and peripheral devices and disconnect the power cords and all external cables, if necessary.

Note: When you disconnect the power source from the server, you lose the ability to view the LEDs because the LEDs are not lit when the power source is removed. Before you disconnect the power source, make a note of which LEDs are lit, including the LEDs that are lit on the operation information panel, on the light path diagnostics panel, and LEDs inside the server on the system board.

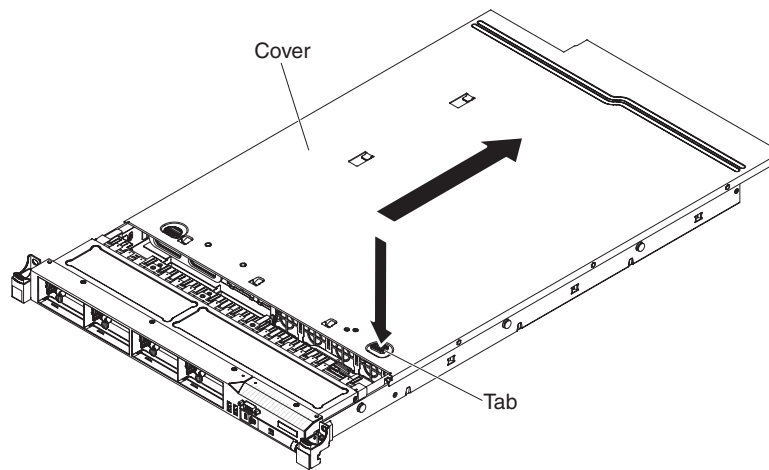

Figure 28. Cover removal

3. If the server has been installed in a rack, slide the server out from the rack enclosure.
4. Press down firmly on the blue tab on the top (near the front of the server) of the cover and slide the cover toward the rear of the server until the cover has disengaged from the chassis.
5. Lift the server cover off the server and set it aside.

Attention: For proper cooling and airflow, replace the server cover before you turn on the server.

Installing the cover

Use this information to install the cover.

About this task

To install the server cover, complete the following steps:

Procedure

1. Make sure that all cables, adapters, and other components are installed and seated correctly and that you have not left loose tools or parts inside the server. Also, make sure that all internal cables are correctly routed.

Important: Before you slide the cover forward, make sure that all the tabs on both the front, rear, and side of the cover engage the chassis correctly. If all the tabs do not engage the chassis correctly, it will be very difficult to remove the cover later.

2. Position the cover on top of the server.

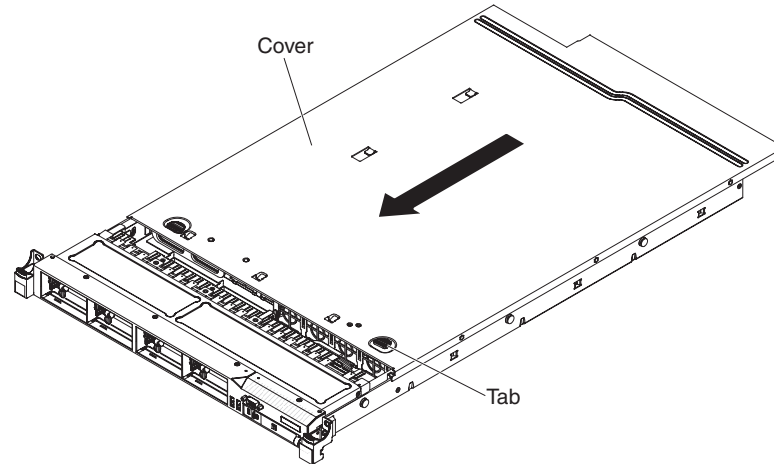

Figure 29. Cover installation

3. Slide the cover toward the front of the server.
4. Make sure that the cover correctly engages all the inset tabs on the server.
5. Slide the server all the way into the rack until it latches.
6. Reconnect the external cables and power cords.

Removing the microprocessor 2 air baffle

Use this information to remove the microprocessor 2 air baffle.

About this task

To remove the microprocessor 2 air baffle, complete the following steps:

Procedure

1. Read the safety information that begins on "Safety" on page vii and "Installation guidelines" on page 347.
2. Turn off the server and peripheral devices and disconnect the power cords and all external cables.
3. Remove the cover (see "Removing the cover" on page 356).
4. Lift the air baffle up, making sure that the tab comes out of the hole on the side of the power-supply cage; then, remove the air baffle from the server and set it aside.

Attention: For proper cooling and airflow, replace the air baffle before you turn on the server. Operating the server with the air baffle removed might damage server components.

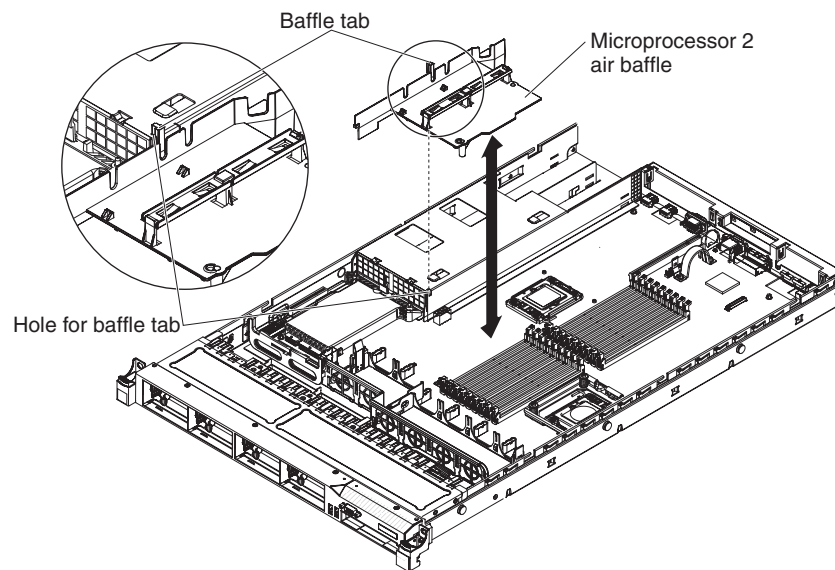

Figure 30. Microprocessor 2 air baffle removal

Installing the microprocessor 2 air baffle

Use this information to install the microprocessor 2 air baffle.

About this task

To install the air baffle, complete the following steps:

Procedure

1. Read the safety information that begins on “Safety” on page vii and “Installation guidelines” on page 347.
2. Align the microprocessor 2 air baffle tab with the hole on the side of the power-supply cage; then insert the tab into the hole on the cage (make sure that the front end of the air baffle is lined up with the blue touch point tab on the left side of fan 6). Press the air baffle down until it is securely seated.

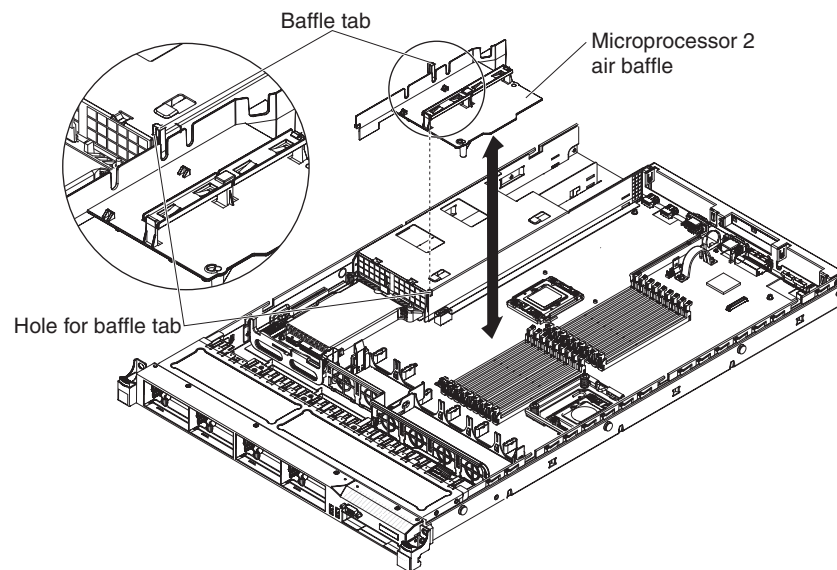

Figure 31. Microprocessor 2 air baffle installation

3. Install the cover (see “Installing the cover” on page 357).
4. Slide the server into the rack.
5. Reconnect the power cords and any cables that you removed.
6. Turn on the peripheral devices and the server.

Removing the DIMM air baffle

Use this information to remove the DIMM air baffle.

About this task

To remove the DIMM air baffle, complete the following steps:

Procedure

1. Read the safety information that begins on "Safety" on page vii and "Installation guidelines" on page 347.
2. Turn off the server and peripheral devices and disconnect all power cords and external cables if necessary.
3. Remove the cover (see "Removing the cover" on page 356).
4. Grasp the DIMM air baffle and lift the baffle up, making sure that the pin comes out of the pin hole on the system board to the left of DIMM connector 8.

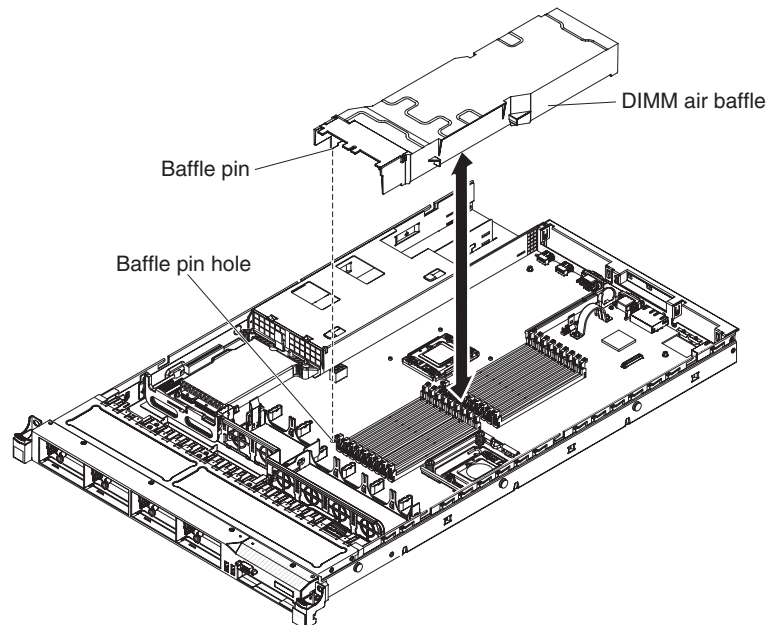

Figure 32. DIMM air baffle removal

5. Remove it from the server and set it aside.

Attention: For proper cooling and airflow, replace the air baffle before you turn on the server. Operating the server with an air baffle removed might damage server components.

Installing the DIMM air baffle

Use this information to install the DIMM air baffle.

About this task

To install the DIMM air baffle, complete the following steps:

Procedure

1. Align the DIMM air baffle over the DIMMs so that the baffle pin on the left side of the air baffle aligns with the pin hole next to DIMM connector 8 on the system board, and lower it into the server.

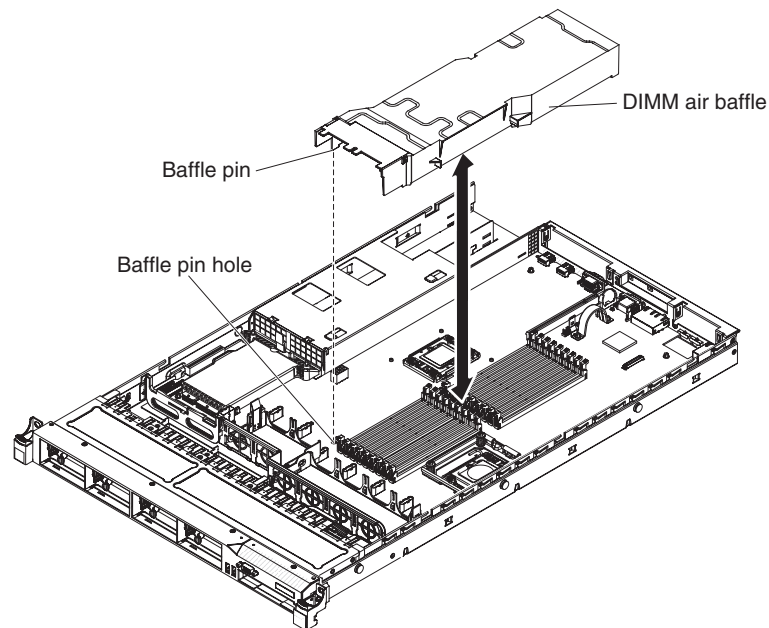

Figure 33. DIMM air baffle installation

2. Install the cover.
3. Slide the server into the rack.
4. Reconnect the power cord and any cables that you removed.
5. Turn on the peripheral devices and the server.

Attention: For proper cooling and airflow, replace the air baffle before turning on the server. Operating the server with an air baffle removed might damage server components.

Removing a memory module

Use this information to remove a memory module.

About this task

To remove a dual inline memory module (DIMM), complete the following steps:

Procedure

1. Read the safety information that begins on “Safety” on page vii and “Installation guidelines” on page 347.
2. Turn off the server and peripheral devices and disconnect all power cords.
3. Remove the cover (see “Removing the cover” on page 356).
4. Remove the DIMM air baffle (see “Removing the DIMM air baffle” on page 360).
5. Carefully open the retaining clips on each end of the DIMM connector and remove the DIMM.

Attention: To avoid breaking the retaining clips or damaging the DIMM connectors, open and close the clips gently.

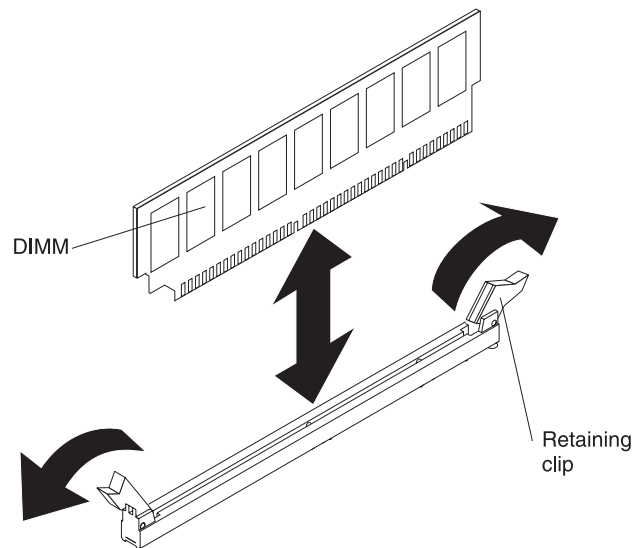

Figure 34. DIMM removal

Results

If you are instructed to return the DIMM, follow all packaging instructions, and use any packaging materials for shipping that are supplied to you.

Installing a memory module

The following notes describe the types of DIMMs that the server supports and other information that you must consider when you install DIMMs.

- When you install or remove DIMMs, the server configuration information changes. When you restart the server, the system displays a message that indicates that the memory configuration has changed.
- The server supports only industry-standard double-data-rate 3 (DDR3), 800, 1066, or 1333 MHz, PC3-10600R-999, registered or unbuffered, synchronous dynamic random-access memory (SDRAM) dual inline memory modules (DIMMs) with error correcting code (ECC). See <http://www.ibm.com/supportportal/> for a list of supported memory modules for the server.
 - The specifications of a DDR3 DIMM are on a label on the DIMM, in the following format.

ggg eRxff-PC3-wwwwm-aa-bb-cc

where:

- *ggg* is the total capacity of the DIMM (for example, 1GB, 2GB, or 4GB)
- *e* is the number of ranks
 - 1 = single-rank
 - 2 = dual-rank
 - 4 = quad-rank
- *ff* is the device organization (bit width)
 - 4 = x4 organization (4 DQ lines per SDRAM)
 - 8 = x8 organization
 - 16 = x16 organization
- *wwww* is the DIMM bandwidth, in MBps
 - 6400 = 6.40 GBps (PC3-800 SDRAMs, 8-byte primary data bus)
 - 8500 = 8.53 GBps (PC3-1066 SDRAMs, 8-byte primary data bus)
 - 10600 = 10.66 GBps (PC3-1333 SDRAMs, 8-byte primary data bus)
 - 12800 = 12.80 GBps (PC3-1600 SDRAMs, 8-byte primary data bus)
- *m* is the DIMM type
 - E = Unbuffered DIMM (UDIMM) with ECC (x72-bit module data bus)
 - R = Registered DIMM (RDIMM)
 - U = Unbuffered DIMM with no ECC (x64-bit primary data bus)
- *aa* is the CAS latency, in clocks at maximum operating frequency
- *bb* is the JEDEC SPD Revision Encoding and Additions level
- *cc* is the reference design file for the design of the DIMM
- *d* is the revision number of the reference design of the DIMM

Note: To determine the type of a DIMM, see the label on the DIMM. The information on the label is in the format *xxxxx nRxxx PC3-xxxxx-xx-xx-xxx*. The numeral in the sixth numerical position indicates whether the DIMM is single-rank (n=1), dual-rank (n=2), or quad-rank (n=4).

- The following rules apply to DDR3 DIMM speed as it relates to the number of DIMMs in a channel:
 - When you install 1 DIMM per channel, the memory runs at 1333 MHz
 - When you install 2 DIMMs per channel, the memory runs at 1066 MHz
 - When you install 3 DIMMs per channel, the memory runs at 800 MHz

- All channels in a server run at the fastest common frequency
- Do not install registered and unbuffered DIMMs in the same server
- The maximum memory speed is determined by the combination of the microprocessor, DIMM speed, and the number of DIMMs installed in each channel.
- In two-DIMM-per-channel configuration, a server with an Intel Xeon X5600 series microprocessor automatically operates with a maximum memory speed of up to 1333 MHz when one of the following conditions is met:
 - Two 1.5 V single-rank or dual-rank RDIMMs are installed in the same channel. In the Setup utility, **Memory speed** is set to **Max performance** mode
 - Two 1.35 V single-rank or dual-rank RDIMMs are installed in the same channel. In the Setup utility, **Memory speed** is set to **Max performance** and **LV-DIMM power** is set to **Enhance performance** mode. The 1.35 V RDIMMs will function at 1.5 V
- The server supports a maximum of 18 single-rank or dual-rank RDIMMs. The server supports up to 12 single-rank or dual-rank UDIMMs or quad-rank RDIMMs.
- The server supports three single-rank or dual-rank DIMMs per channel. The server supports a maximum of two quad-rank RDIMMs per channel. The following table shows an example of the maximum amount of memory that you can install using ranked DIMMs:

Table 15. Maximum memory installation using ranked DIMMs

Number of DIMMs	DIMM type	DIMM size	Total memory
12	Single-rank UDIMMs	2 GB	24 GB
12	Dual-rank UDIMMs	4 GB	48 GB
18	Single-rank RDIMMs	2 GB	36 GB
18	Dual-rank RDIMMs	2 GB	36 GB
18	Dual-rank RDIMMs	4 GB	72 GB
18	Dual-rank RDIMMs	8 GB	144 GB
12	Quad-rank RDIMMs	16 GB	192 GB
18	Dual-rank RDIMMs	16 GB	288 GB

- The RDIMM options that are available for the server are 2 GB, 4 GB, 8 GB, and 16 GB. The server supports a minimum of 2 GB and a maximum of 288 GB of system memory using RDIMMs.

For 32-bit operating systems only: Some memory is reserved for various system resources and is unavailable to the operating system. The amount of memory that is reserved for system resources depends on the operating system, the configuration of the server, and the configured PCI devices.
- The UDIMM options that are available for the server are 2 GB and 4 GB. The server supports a minimum of 2 GB and a maximum of 48 GB of system memory using UDIMMs.

Note: The amount of usable memory is reduced depending on the system configuration. A certain amount of memory must be reserved for system resources. To view the total amount of installed memory and the amount of configured memory, run the Setup utility. For additional information, see “Configuring the server” on page 456.
- A minimum of one DIMM must be installed for each microprocessor. For example, you must install a minimum of two DIMMs if the server has two

microprocessors installed. However, to improve system performance, install a minimum of three DIMMs for each microprocessor.

- DIMMs in the same channel must be the same type (RDIMM or UDIMM) to ensure that the server will operate correctly.
- When you install one quad-rank RDIMM in a channel, install it in the DIMM connector furthest away from the microprocessor.
- Do not install one quad-rank RDIMM in one channel and three RDIMMs in another channel.

The following illustration shows the location of the DIMM connectors on the system board.

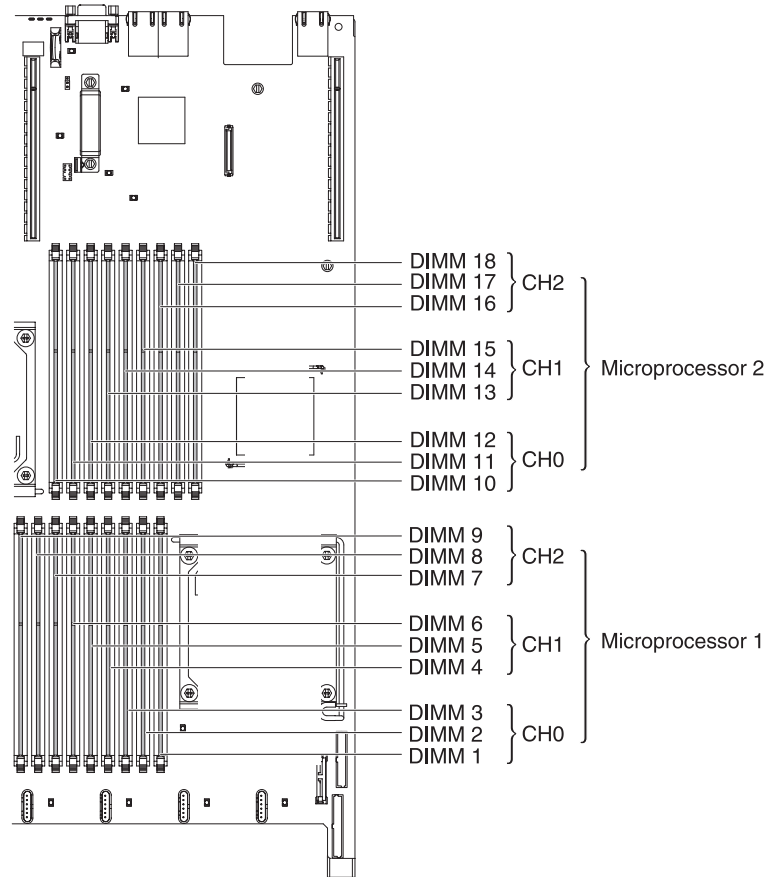

Figure 35. DIMM connectors location

DIMM installation sequence

Depending on the server model, the server may come with a minimum of one 2 GB or 4 GB DIMM installed in slot 3.

When you install additional DIMMs, install them in the order shown in the following table to optimize system performance. In non-mirroring mode, all three channels on the memory interface for each microprocessor can be populated in any order and have no matching requirements.

Table 16. Non-mirroring (normal) mode DIMM installation sequence

Installed microprocessor	DIMM connector population sequence
Microprocessor socket 1	3, 6, 9, 2, 5, 8, 1, 4, 7
Microprocessor socket 2	12, 15, 18, 11, 14, 17, 10, 13, 16

Memory mirroring

Memory-mirroring mode replicates and stores data on two pairs of DIMMs within two channels simultaneously. If a failure occurs, the memory controller switches from the primary pair of memory DIMMs to the backup pair of DIMMs.

To enable memory mirroring through the Setup utility, select **System Settings > Memory**. For more information, see “Using the Setup utility” on page 460. When you use the memory mirroring feature, consider the following information:

- When you use memory mirroring, you must install a pair of DIMMs at a time. One DIMM must be in channel 0, and the mirroring DIMM must be in the same slot in channel 1. The two DIMMs in each pair must be identical in size, type, and rank (single or dual), and organization, but not in speed. The channels run at the speed of the slowest DIMM in any of the channels.
- Channel 2, DIMM connectors 7, 8, 9, 16, 17, and 18 are not used in memory-mirroring mode.
- The maximum available memory is reduced to half of the installed memory when memory mirroring is enabled. For example, if you install 64 GB of memory using RDIMMs, only 32 GB of addressable memory is available when you use memory mirroring.

The following diagram shows the memory channel interface layout with the DIMM installation sequence for mirroring mode. The numbers within the boxes indicate the DIMM population sequence in pairs within the channels, and the numbers next to the boxes indicate the DIMM connectors within the channels. For example, the following illustration shows the first pair of DIMMs (indicated by ones (1) inside the boxes) should be installed in DIMM connectors 1 on channel 0 and DIMM connector 2 on channel 1. DIMM connectors 3, 6, 9, 12, 15, and 18 on channel 2 are not used in memory-mirroring mode.

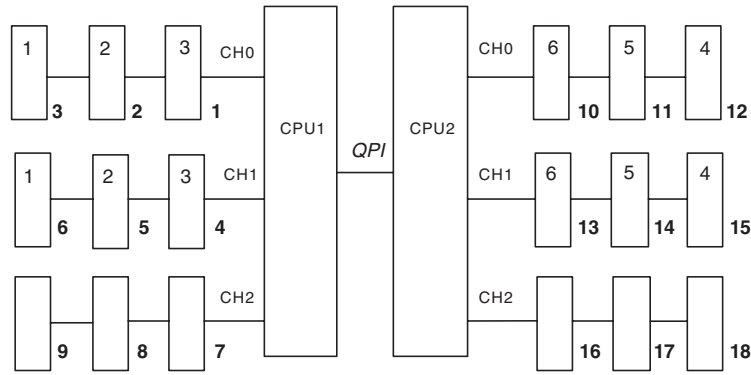

Figure 36. Memory channel interface layout

The following table lists the DIMM connectors on each memory channel.

Table 17. Connectors on each memory channel

Memory channel	DIMM connector
Channel 0	1, 2, 3, 10, 11, 12
Channel 1	4, 5, 6, 13, 14, 15
Channel 2	7, 8, 9, 16, 17, 18

The following illustration shows the memory connector layout that is associated with each microprocessor. For example, DIMM connectors 10, 11, 12, 13, 14, 15, 16, 17, and 18 (DIMM connectors are shown underneath the boxes) are associated with microprocessor 2 (CPU2) and DIMM connectors 1, 2, 3, 4, 5, 6, 7, 8, and 9 are associated with microprocessor 1 (CPU1). The numbers within the boxes indicate the installation sequence of the DIMM pairs. For example, the first DIMM pair (indicated within the boxes by ones (1)) should be installed in DIMM connectors 1 and 2, which is associated with microprocessor 1 (CPU1).

Note: You can install DIMMs for microprocessor 2 as soon as you install microprocessor 2; you do not have to wait until all of the DIMM slots for microprocessor 1 are filled.

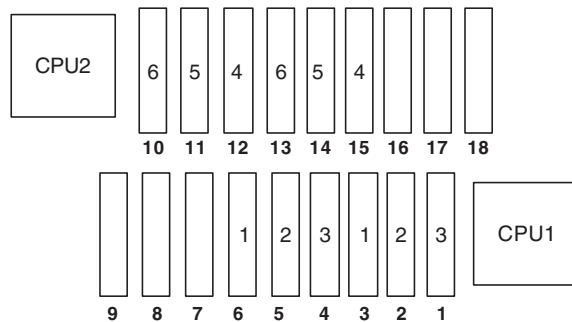

Figure 37. Memory connectors associated with each microprocessor for memory mirroring

The following table shows the installation sequence for installing DIMMs in memory-mirroring mode:

Table 18. Memory mirroring mode DIMM population sequence

Number of DIMMs	Number of installed microprocessor	DIMM connector
First pair of DIMMs	1	3, 6
Second pair of DIMMs	1	2, 5
Third pair of DIMMs	1	1, 4
Fourth pair of DIMMs	2	12, 15
Fifth pair of DIMMs	2	11, 14
Sixth pair of DIMMs	2	10, 13
Table note: DIMM connectors 7, 8, 9, 16, 17, and 18 are not used in memory-mirroring mode.		

Online-spare memory

The memory online-spare feature disables the failed memory from the system configuration and activates an online-spare DIMM to replace the failed active DIMM.

You can enable either online-spare memory or memory mirroring in the Setup utility (see “Using the Setup utility” on page 460). When you use the memory online-spare feature, consider the following information:

- The memory online-spare feature is supported on server models with an Intel Xeon™ 5600 series microprocessor.
- When you enable the memory online-spare feature, you must install three DIMMs per microprocessor at a time. The first DIMM must be in channel 0, the second DIMM in channel 1, and the third DIMM in channel 2. The DIMMs must be identical in size, type, rank, and organization, but not in speed. The channels run at the speed of the slowest DIMM in any of the channels.
- The maximum available memory is reduced to 2/3 of the installed memory when memory online-spare mode is enabled. For example, if you install 72 GB of memory using RDIMMs, only 48 GB of addressable memory is available when you use memory online-spare.

The following table shows the installation sequence for installing DIMMs for each microprocessor in memory online-spare mode:

Table 19. Memory online-spare mode DIMM population sequence

Installed Microprocessor	DIMM connector
Microprocessor 1	3, 6, 9
	3, 6, 9, 2, 5, 8
	3, 6, 9, 2, 5, 8, 1, 4, 7
Microprocessor 2	12, 15, 18,
	12, 15, 18, 11, 14, 17,
	12, 15, 18, 11, 14, 17, 10, 13, 16

Installing a DIMM

Use this information to install a DIMM.

About this task

To install a DIMM, complete the following steps:

Procedure

1. Read the safety information that begins on “Safety” on page vii and “Installation guidelines” on page 347.
2. Turn off the server and peripheral devices and disconnect the power cords and all external cables, if necessary.
3. Remove the cover (see “Removing the cover” on page 356).
4. Open the retaining clip on each end of the DIMM connector.
Attention: To avoid breaking the retaining clips or damaging the DIMM connectors, open and close the clips gently.

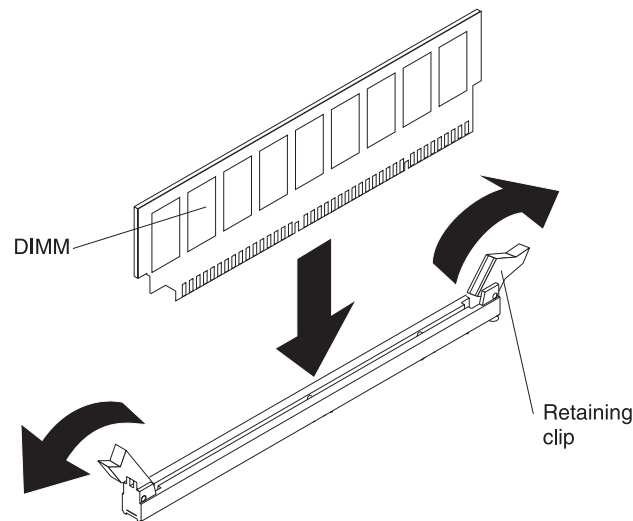

Figure 38. DIMM installation

5. Touch the static-protective package that contains the DIMM to any unpainted metal surface on the outside of the server. Then, remove the DIMM from the package.
6. Turn the DIMM so that the DIMM keys align correctly with the connector.
7. Insert the DIMM into the connector by aligning the edges of the DIMM with the slots at the ends of the DIMM connector (see “System-board optional device connectors” on page 23 for the locations of the DIMM connectors).
8. Firmly press the DIMM straight down into the connector by applying pressure on both ends of the DIMM simultaneously. The retaining clips snap into the locked position when the DIMM is firmly seated in the connector.

Note: If there is a gap between the DIMM and the retaining clips, the DIMM has not been correctly inserted; open the retaining clips, remove the DIMM, and then reinsert it.
9. Reconnect the power cord and any cables that you removed.
10. Replace the cover (see “Installing the cover” on page 357).
11. Turn on the peripheral devices and the server.

Removing a hot-swap hard disk drive

Use this information to remove a hot-swap hard disk drive.

About this task

Attention:

- To avoid damage to the hard disk drive connectors, make sure that the server cover is in place and fully closed whenever you install or remove a hard disk drive.
- To make sure that there is adequate system cooling, do not operate the server for more than 2 minutes without either a hard disk drive or a filler panel installed in each bay.
- Before you make changes to disk drives, disk drive controllers (including controllers that are integrated on the system board), disk drive backplanes, or disk drive cables, back up all important data that is stored on hard disks.
- Before you remove any component of a RAID array, back up all RAID configuration information.

To remove a hot-swap hard disk drive, complete the following steps.

Procedure

1. Read the safety information that begins on “Safety” on page vii and “Installation guidelines” on page 347.
2. Make sure you save the data on your drive, especially if it is part of a RAID array, before you remove it from the server.
3. Slide the release latch (orange) gently to the left to unlock the drive handle.

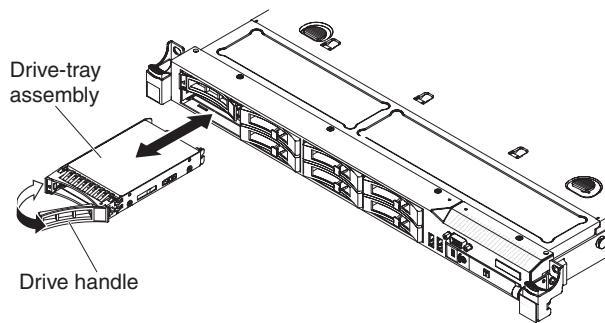

Figure 39. Hot-swap hard disk drive removal

4. Grasp the handle and slide the drive out of the drive bay.

Results

If you are instructed to return the DIMM, follow all packaging instructions, and use any packaging materials for shipping that are supplied to you.

Installing a hot-swap hard disk drive

Use this information to install a hot-swap hard disk drive.

About this task

The following notes describe the type of hard disk drives that the server supports and other information that you must consider when you install a hard disk drive.

- Locate the documentation that comes with the hard disk drive and follow those instructions in addition to the instructions in this chapter.
- Make sure that you have all the cables and other equipment that are specified in the documentation that comes with the drive.
- Select the bay in which you want to install the drive.
- Check the instructions that come with the drive to determine whether you have to set any switches or jumpers on the drive. If you are installing a SAS or SATA device, be sure to set the SAS or SATA ID for that device.
- The server supports up to eight 2.5-inch hot-swap SAS or hot-swap SATA hard disk drives.
- The electromagnetic interference (EMI) integrity and cooling of the server are protected by having all bays and PCI and PCI Express slots covered or occupied. When you install a drive, PCI, or PCI Express adapter, save the EMC shield and filler panel from the bay or PCI or PCI Express adapter slot cover in the event that you later remove the device.
- For a complete list of supported optional devices for the server, see <http://www.ibm.com/systems/info/x86servers/serverproven/compat/us/>.

To install a 2.5-inch hot-swap SAS or SATA hard disk drive, complete the following steps:

Procedure

1. Read the safety information that begins on “Safety” on page vii and “Installation guidelines” on page 347.
2. Remove the filler panel from the empty drive bay.
3. Touch the static-protective package that contains the drive to any unpainted metal surface on the server; then, remove the drive from the package and place it on a static-protective surface.
4. Install the hard disk drive in the drive bay:
 - a. Make sure that the tray handle is in the open (unlocked) position.
 - b. Align the drive assembly with the guide rails in the bay.

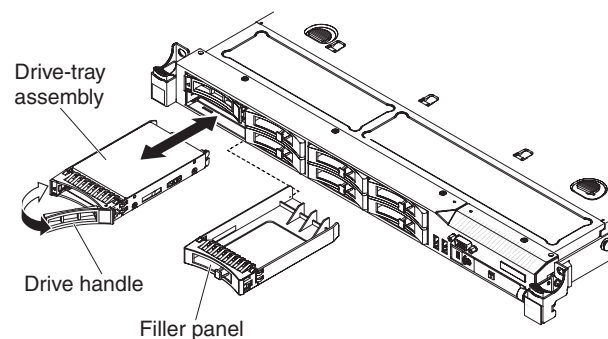

Figure 40. Hot-swap hard disk drive installation

- c. Gently push the drive assembly into the bay until the drive stops.
- d. Rotate the tray handle to the closed (locked) position.
- e. Check the hard disk drive status LED to verify that the hard disk drive is operating correctly. If the amber hard disk drive status LED for a drive is lit continuously, that drive is faulty and must be replaced. If the green hard disk drive activity LED is flashing, the drive is being accessed.

Note: If the server is configured for RAID operation using a ServeRAID adapter, you might have to reconfigure your disk arrays after you install hard disk drives. See the ServeRAID adapter documentation for additional information about RAID operation and complete instructions for using the ServeRAID adapter.

5. If you are installing additional hot-swap hard disk drives, do so now.
6. Turn on the peripheral devices and the server.

IDs for hot-swap hard disk drives

The hot-swap-drive ID that is assigned to each drive is printed on the front of the server.

The following illustration shows the location of the IDs of the hard disk drives. The ID numbers and the drive bay numbers are the same.

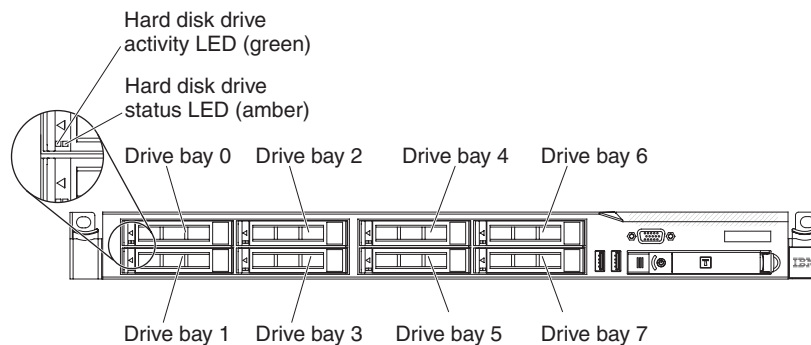

Figure 41. Hot-swap hard disk drive IDs

Removing a simple-swap hard disk drive

Use this information to remove a simple-swap hard disk drive.

About this task

You must turn off the server before removing simple-swap drives from the server. To remove a simple-swap SATA hard disk drive, complete the following steps.

Attention:

- To avoid damage to the hard disk drive connectors, make sure that the server cover is in place and fully closed whenever you install or remove a hard disk drive.
- To make sure that there is adequate system cooling, do not operate the server for more than 2 minutes without either a hard disk drive or a filler panel installed in each bay.

To remove a simple-swap hard disk drive, complete the following steps.

Procedure

1. Read the safety information that begins on “Safety” on page vii and “Installation guidelines” on page 347.
2. Turn off the server and peripheral devices and disconnect the power cords and all external cables.
3. Remove the filler panel from the drive bay.
4. Slide the blue release latch to the right with one finger (to release the drive) while using another finger to grasp the black drive handle and pull the hard disk drives out of the drive bay.

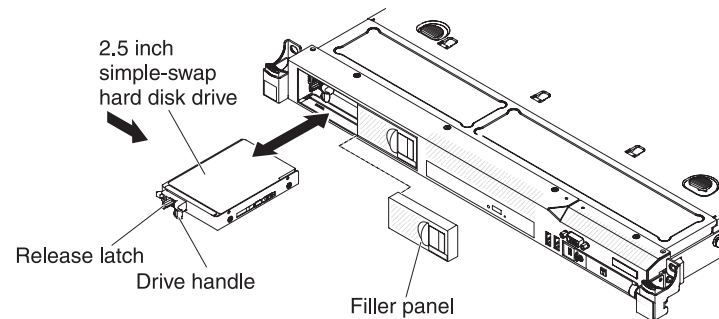

Figure 42. Simple-swap hard disk drive removal

Results

If you are instructed to return the simple-swap drive, follow all packaging instructions, and use any packaging materials for shipping that are supplied to you.

Installing a simple-swap hard disk drive

Use this information to install a simple-swap hard disk drive.

About this task

The simple-swap server models support up to four 2.5-inch simple-swap SATA hard disk drives that are accessible from the front of the server. You must turn off the server before installing simple-swap drives in the server. Before you install a simple-swap SATA hard disk drive, read the following information.

- Locate the documentation that comes with the hard disk drive and follow those instructions in addition to the instructions in this chapter.
- Make sure that you have all the cables and other equipment that are specified in the documentation that comes with the drive.
- Select the bay in which you want to install the drive.
- Check the instructions that come with the drive to determine whether you have to set any switches or jumpers on the drive. If you are installing a SATA device, be sure to set the SATA ID for that device.
- You can install up to four 2.5-inch simple-swap SATA hard disk drives in the server. Do not install hot-swap drives into a simple-swap server model, it is not supported.
- The sequence for installing the hard disk drives is to install the drives starting from bay 0, 1, 2, and 3.
- Simple-swap models of the server do not support the Hypervisor USB flash device and the installation of the SAS/SATA riser card is not supported.

- The simple-swap server models are available only in non-RAID configurations.
- The electromagnetic interference (EMI) integrity and cooling of the server are protected by having all bays and PCI and PCI Express slots covered or occupied. When you install a drive, PCI, or PCI Express adapter, save the EMC shield and filler panel from the bay or PCI or PCI Express adapter slot cover in the event that you later remove the device.
- For a complete list of supported optional devices for the server, see <http://www.ibm.com/systems/info/x86servers/serverproven/compat/us/>.

To install a 2.5-inch simple-swap SATA hard disk drive, complete the following steps:

Procedure

1. Read the safety information that begins on “Safety” on page vii and “Installation guidelines” on page 347.
2. Remove the filler panel from the empty drive bay.
3. Touch the static-protective package that contains the drive to any unpainted metal surface on the server; then, remove the drive from the package and place it on a static-protective surface.
4. Install the hard disk drive in the drive bay:
 - a. Grasp the black drive handle and slide the blue release latch to the right and align the drive assembly with the guide rails in the bay.

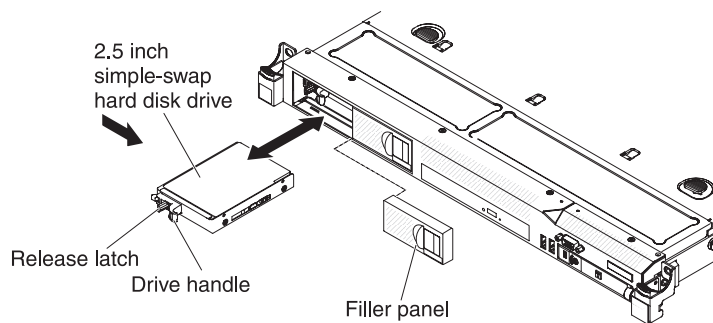

Figure 43. Simple-swap hard disk drive installation

- b. Gently push the drive assembly into the bay until the drive stops.
5. Reinstall the drive bay filler panel that you removed earlier.
 6. If you are installing additional simple-swap hard disk drives, do so now.
 7. Turn on the peripheral devices and the server.

IDs for simple-swap hard disk drives

The simple-swap-drive ID that is assigned to each drive is printed on the front of the server.

The following illustration shows the location of the IDs of the hard disk drives. The ID numbers and the drive bay numbers are the same.

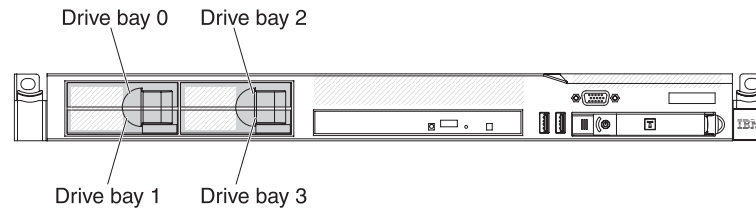

Figure 44. Simple-swap hard disk drive IDs

Removing an optional DVD drive

Use this information to remove an optional DVD drive.

About this task

To remove an optional DVD drive, complete the following steps:

Procedure

1. Read the safety information that begins on “Safety” on page vii and “Installation guidelines” on page 347.
2. Turn off the server and peripheral devices and disconnect all power cords.
3. Remove the cover (see “Removing the cover” on page 356).
4. Press and hold the release tab down as you push the drive from the rear to slide it out of the bay.

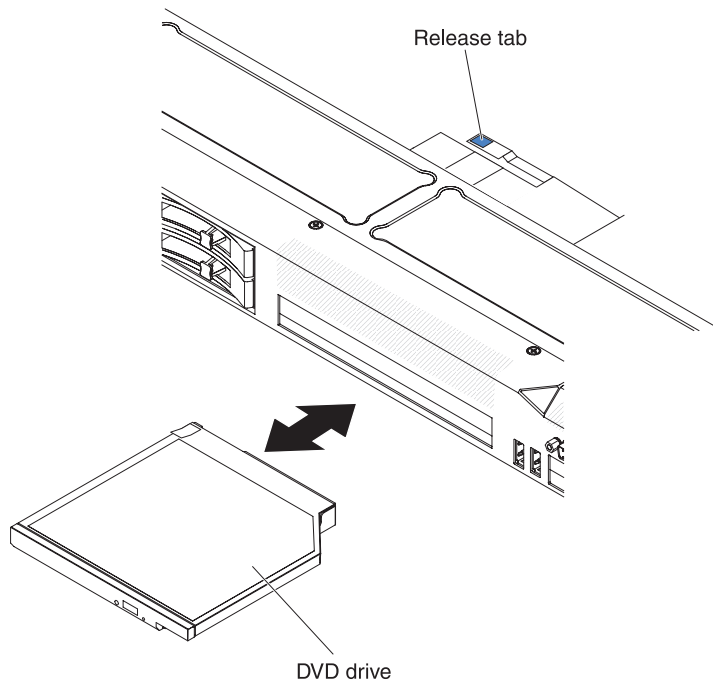

Figure 45. DVD drive removal

5. Slide the drive retention clip from the side of the drive. Save the clip to use when you install the replacement drive or replace the DVD drive filler panel.

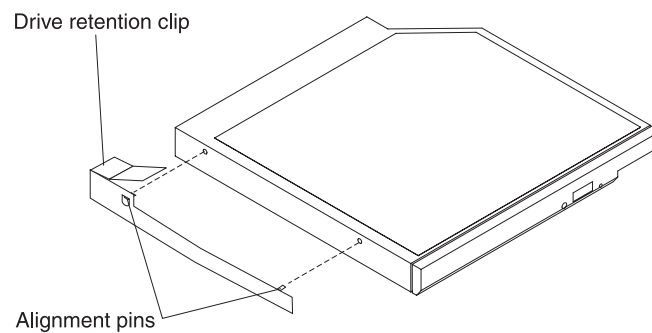

Figure 46. DVD drive retention clip installation

6. Attach the drive retention clip to the side of the DVD drive filler panel that you removed in step 6 on page 378.
7. Slide the DVD drive filler panel into the DVD drive bay until the DVD drive filler panel clicks into place.

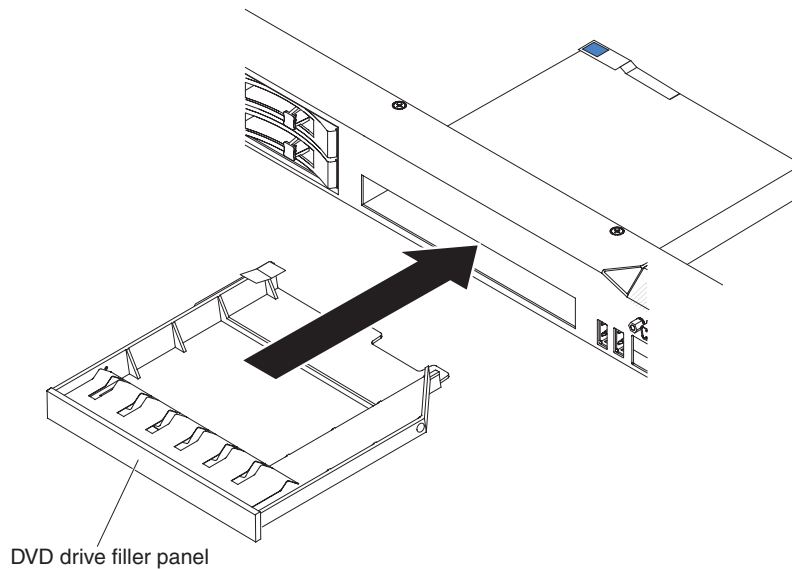

Figure 47. DVD drive filler panel installation

Results

If you are instructed to return the DVD drive, follow all packaging instructions, and use any packaging materials for shipping that are supplied to you.

Installing an optional DVD drive

Use this information to install an optional DVD drive.

About this task

The following notes describe the type of drives that the server supports and other information that you must consider when you install a hard disk drive.

- Locate the documentation that comes with the drive and follow those instructions in addition to the instructions in this chapter.
- Make sure that you have all the cables and other equipment that are specified in the documentation that comes with the drive.
- The server supports one ultra-slim SATA optical drive.

If you need to install an optional DVD drive, complete the following steps:

Procedure

1. Read the safety information that begins on “Safety” on page vii and “Installation guidelines” on page 347.
2. Turn off the server and peripheral devices and disconnect the power cords and all external cables.
3. Remove the cover (see “Removing the cover” on page 356).
4. If your server does not come with an optical drive bay, install the optical drive cage and replace the bezel (see “Installing an optional optical drive cage” on page 421 and “Installing the bezel” on page 419).
5. Disconnect the DVD drive cable (see “Removing the DVD cable” on page 422).

6. Remove the DVD drive filler panel if it is installed. locate the blue release tab on the rear of the DVD drive filler panel; then, while you press the tab, push the DVD drive filler panel out of the drive bay.

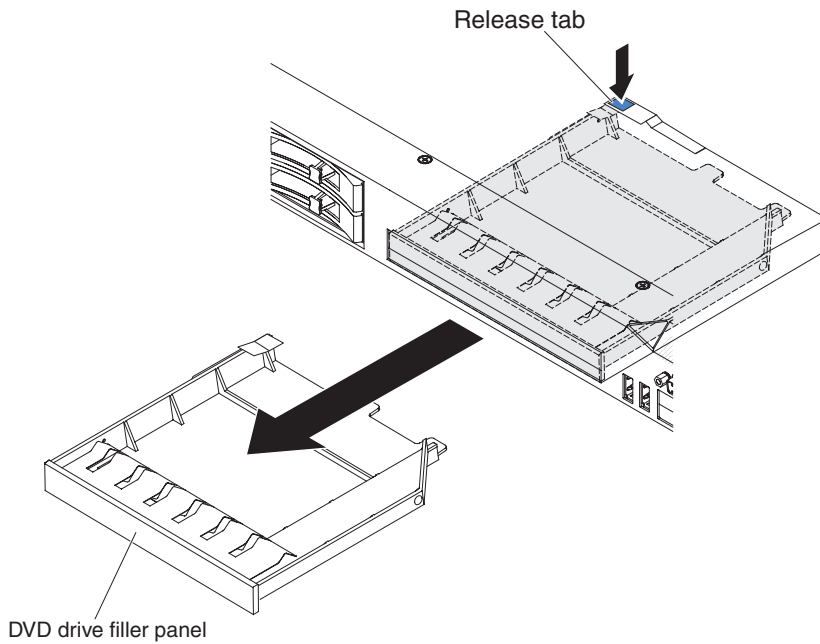

Figure 48. DVD drive filler panel removal

7. Remove the retention clip from the side of the DVD drive filler panel. Save the DVD drive filler panel for future use.

Note: If you are installing an optical drive that contains a laser, observe the following safety precaution.

Statement 3



CAUTION:

When laser products (such as CD-ROMs, DVD drives, fiber optic devices, or transmitters) are installed, note the following:

- Do not remove the covers. Removing the covers of the laser product could result in exposure to hazardous laser radiation. There are no serviceable parts inside the device.
- Use of controls or adjustments or performance of procedures other than those specified herein might result in hazardous radiation exposure.



DANGER

Some laser products contain an embedded Class 3A or Class 3B laser diode. Note the following.

Laser radiation when open. Do not stare into the beam, do not view directly with optical instruments, and avoid direct exposure to the beam.



Class 1 Laser Product
Laser Klasse 1
Laser Klass 1
Luokan 1 Laserlaite
Appareil À Laser de Classe 1

8. Touch the static-protective package that contains the new optical drive to any unpainted metal surface on the server; then, remove the drive from the package and place it on a static-protective surface.
9. Follow the instructions that come with the drive to set any jumpers or switches.
10. Attach the drive retention clip that you removed from the DVD drive filler panel to the side of the new DVD drive.

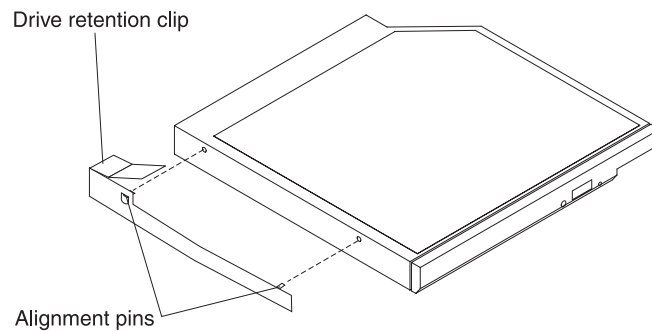

Figure 49. DVD drive retention clip installation

11. Align the DVD drive in the drive bay and slide the DVD drive into the optical drive bay until the DVD drive clicks into place.

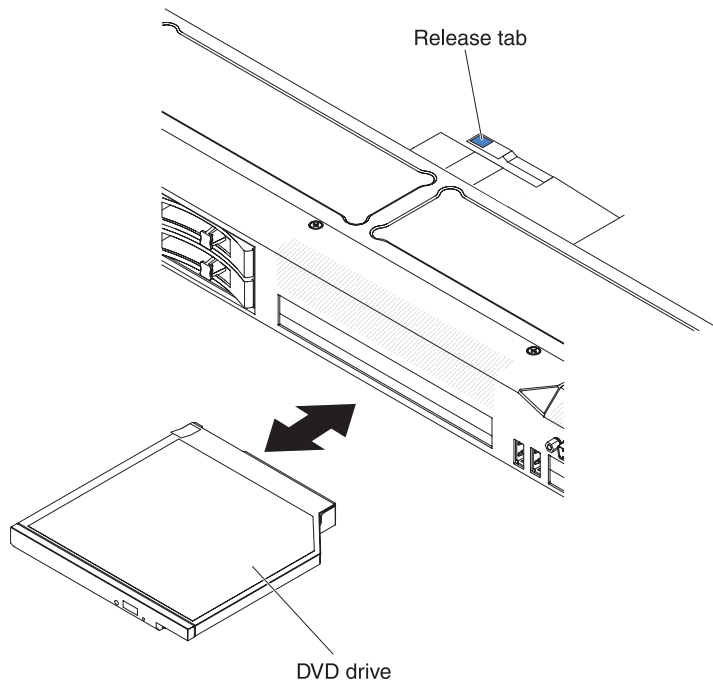

Figure 50. DVD drive installation

12. Connect the DVD drive cable (see "Installing the DVD cable" on page 423). The following illustration shows the cable routing for the DVD drive:

Note: The DVD cable should go on the top of the operation information panel cable (in the middle) and the Video/USB cable (on the bottom) when all three cables are installed in the server.

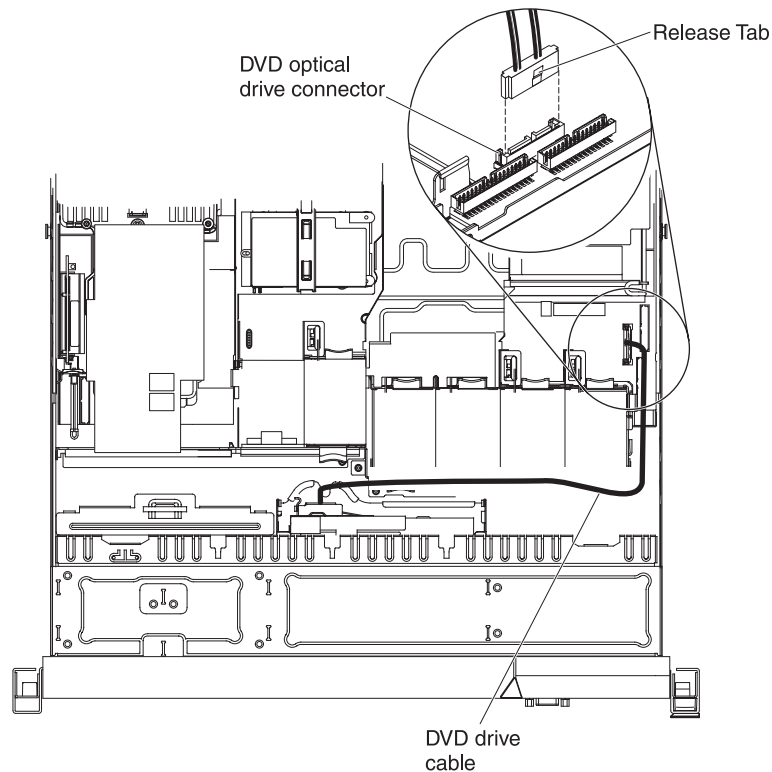

Figure 51. DVD drive cable connection

13. Reconnect the power cord and any cables that you removed.
14. Turn on the peripheral devices and the server.

Removing an adapter

Use this information to remove an adapter.

About this task

To remove an adapter, complete the following steps:

Procedure

1. Read the safety information that begins on “Safety” on page vii and “Installation guidelines” on page 347.
2. Turn off the server and peripheral devices and disconnect all power cords.
3. Remove the cover (see “Removing the cover” on page 356).
4. Disconnect any cables from the adapter.
5. Grasp the riser-card assembly at the rear edge and lift to remove the riser-card assembly.
6. Place the riser-card assembly on a flat, static-protective surface.
7. Carefully grasp the adapter by its top edge or upper corners, and pull the adapter from the riser-card assembly.

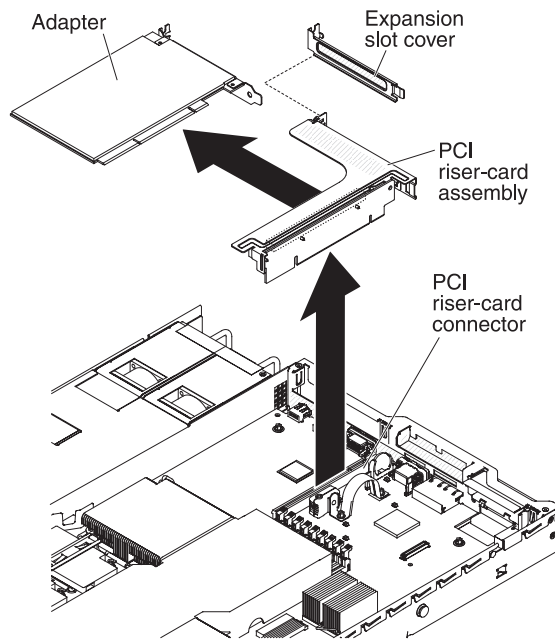

Figure 52. Adapter removal

Results

If you are instructed to return the adapter, follow all packaging instructions, and use any packaging materials for shipping that are supplied to you.

Replacing an adapter

Use this information to replace an adapter.

About this task

The following notes describe the types of adapters that the server supports and other information that you must consider when you install an adapter:

- Locate the documentation that comes with the adapter and follow those instructions in addition to the instructions in this section.
- The server provides one SAS/SATA RAID riser-card slot on the system board. See “System-board optional device connectors” on page 23 for the location of the SAS/SATA RAID riser-card slot. The ServeRAID-BR10il v2, ServeRAID-M1015, ServeRAID-M5014, or ServeRAID-M5015 adapter comes installed on some models of the server. You can replace the IBM ServeRAID SAS/SATA adapter with an optional IBM ServeRAID SAS/SATA adapter in the slot. For configuration information, see the ServeRAID documentation at <http://www.ibm.com/supportportal/>.

Important: To ensure that any of your ServeRAID 10i, 10is, or 10M adapters function properly on UEFI-based servers, make sure that the adapter firmware level is updated to at least 11.x.x-XXX , and the supporting drivers.

Attention: Some cluster solutions require specific code levels or coordinated code updates. If the device is part of a cluster solution, verify that the latest level of code is supported for the cluster solution before you update the code.

- Do not set the maximum digital video adapter resolution above 1600 x 1200 at 75 Hz for an LCD monitor. This is the highest resolution that is supported for any add-on video adapter that you install in the server.

- Any high-definition video-out connector or stereo connector on any add-on video adapter is not supported
- The server does not support full-length, full-height PCI-X adapters or legacy 5 V PCI adapters.
- When you install any PCI adapter, the power cords must be disconnected from the power source before you remove the PCI Express riser-card assembly and the PCI-X riser-card assembly. Otherwise, the active power management event signal will be disabled by the system-board logic, and the Wake on LAN feature might not work. However, after the server is powered-on locally, the active power manager active power management event signal will be enabled by the system-board logic.
- If you switch the PCI adapter from slot 1 riser assembly to slot 2, you will need to remove the screw from the standard bracket and then replace the standard bracket with the low-profile bracket.
- The server provides two PCI riser-card slots on the system board. A PCI riser assembly with a bracket is installed in slot 2. The following information indicates the riser-card slots and the type of adapters that the riser cards support:
 - Standard models of the server come with two PCI Express riser-card assemblies installed. If you want to replace them with PCI-X riser-card assemblies, you must order the PCI-X riser-card assembly option, which includes the bracket.
 - A PCI Express riser-card assembly has a black connector and supports PCI Express adapters, and a PCI-X riser-card assembly has a white (light in color) connector and supports PCI-X adapters.
 - PCI riser slot 1 (the farthest slot from the power supplies). This slot supports only low-profile adapters.
 - PCI riser slot 2 (the closest slot to the power supplies). This slot supports only full-height, half-length adapters. You must install a PCI riser-card assembly in slot 2 even if you do not install an adapter.

The following table lists the supported configurations for the PCI rise-cardr slots.

Table 20. PCI riser slots supported configurations

PCI riser-card slot number	Configuration 1	Configuration 2	Configuration 3	Configuration 4
Slot 1	PCI Express Gen 2 (x16) card with a PCI Express riser card with a low-profile bracket	PCI Express Gen 2 (x16) card with a PCI Express riser card with a low-profile bracket	PCI-X 1.0a 64-bit/133 MHz care with a PCI-X riser card with a low-profile bracket	PCI-X 1.0a 64-bit/133 MHz card with a PCI-X riser card with a low-profile bracket
Slot 2	PCI Express Gen 2 (x16) card with a PCI Express riser card with a standard bracket	PCI-X 1.0a 64-bit/133 MHz card with a PCI-X riser card with a standard bracket	PCI Express Gen 2 (x16) card with a PCI Express riser card with a standard bracket	PCI-X 1.0a 64-bit/133 MHz card with a PCI-X riser card with a standard bracket

Notes:

1. The instructions in this section apply to any PCI adapter (for example, video graphics adapters or network adapters).

2. Do not set the maximum digital video adapter resolution above 1600 x 1200 at 75 Hz for an LCD monitor. This is the highest resolution that is supported for any add-on video adapter that you install in the server.
3. Any high-definition video-out connector or stereo connector on any add-on video adapter is not supported.

To install an adapter, complete the following steps:

Procedure

1. Read the safety information that begins on “Safety” on page vii and “Installation guidelines” on page 347.
2. Turn off the server and peripheral devices and disconnect all power cords.
3. Remove the cover (see “Removing the cover” on page 356).
4. Follow the cabling instructions, if any come with the adapter. Route the adapter cables before you install the adapter.
5. Insert the adapter into the riser-card assembly, aligning the edge connector on the adapter with the connector on the riser-card assembly. Press the edge of the connector *firmly* into the riser-card assembly. Make sure that the adapter snaps into the riser-card assembly securely.

Attention: When you install an adapter, make sure that the adapter is correctly seated in the riser-card assembly and that the riser-card assembly is securely seated in the riser-card connector on the system board before you turn on the server. An incorrectly seated adapter might cause damage to the system board, the riser-card assembly, or the adapter.

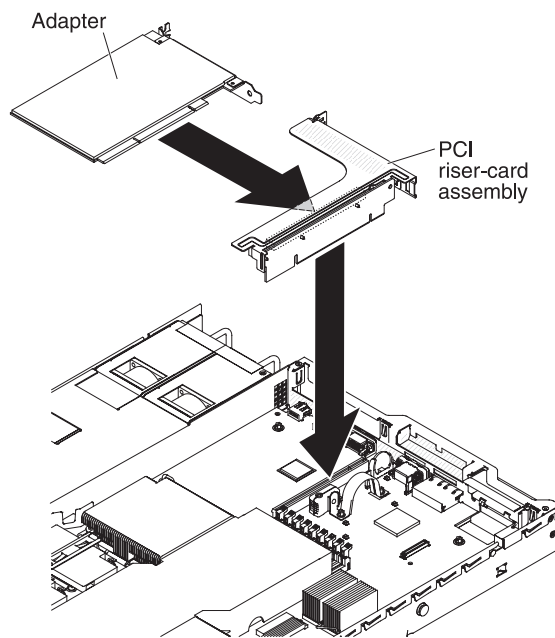

Figure 53. Adapter installation

6. Install the riser-card assembly in the server (see “Installing a PCI riser-card assembly” on page 426).
7. Perform any configuration tasks that are required for the adapter.
8. Install the cover (see “Installing the cover” on page 357).
9. Slide the server into the rack.

10. Reconnect the power cord and any cables that you removed.
11. Turn on the peripheral devices and the server.

Removing the SAS/SATA RAID riser-card assembly

Use this information to remove the SAS/SATA RAID riser-card assembly.

About this task

To remove the SAS/SATA RAID riser-card assembly, complete the following steps:

Procedure

1. Read the safety information that begins on “Safety” on page vii and “Installation guidelines” on page 347.
2. Turn off the server and peripheral devices and disconnect all power cords.
3. Remove the cover (see “Removing the cover” on page 356).
4. Disconnect the cables from the connectors on the SAS/SATA adapter; then, grasp the adapter and pull it out of the connector on the SAS/SATA RAID riser-card assembly.
5. Press the plastic tab (next to the power supply) toward the power supply and remove the entire SAS/SATA RAID riser-card assembly; then, remove the adapter.

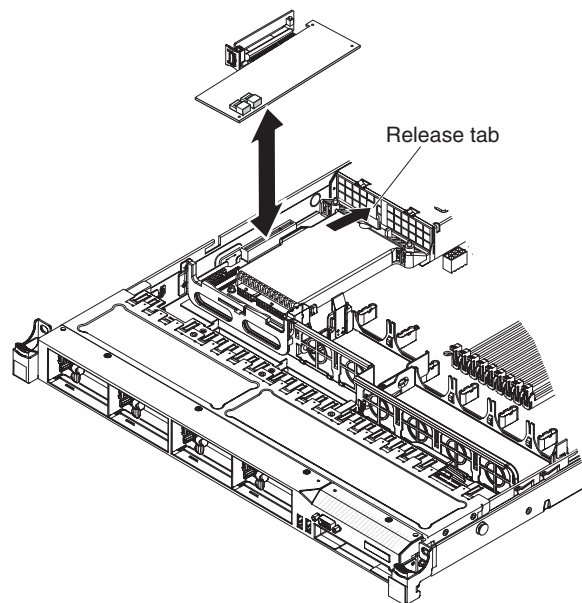

Figure 54. SAS/SATA RAID riser-card assembly removal

6. Remove the flash device from the SAS/SATA RAID riser card, if one is installed (see “Removing a USB embedded hypervisor flash device” on page 404).

Results

If you are instructed to return the SAS/SATA RAID riser-card assembly, follow all packaging instructions, and use any packaging materials for shipping that are supplied to you.

Installing the SAS/SATA RAID riser-card assembly

Use this information to install the SAS/SATA RAID riser-card assembly.

About this task

To install the SAS/SATA RAID riser-card assembly, complete the following steps:

Procedure

1. Read the safety information that begins on “Safety” on page vii and “Installation guidelines” on page 347.
2. Turn off the server and peripheral devices and disconnect all power cords.
3. Remove the cover (see “Removing the cover” on page 356).
4. Reinstall the SAS/SATA adapter, if one was removed (see “Installing a ServeRAID SAS/SATA controller on the SAS/SATA RAID riser card” on page 389).
5. Reinstall the USB flash device, if it was removed (see “Installing a USB embedded hypervisor flash device” on page 405).
6. Align the SAS/SATA RAID riser-card assembly keys correctly with the connector on the system board and press down on the assembly until it is seated firmly into the connector on the system board.

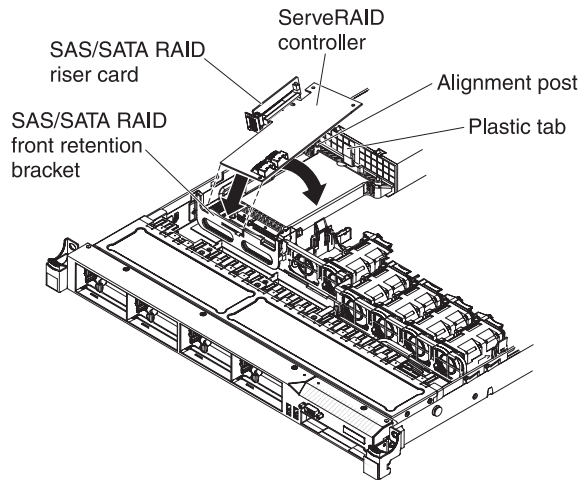

Figure 55. SAS/SATA RAID riser-card assembly installation

7. Connect the signal cables to the SAS/SATA adapter (see step 9 on page 390).
8. Install the cover (see “Installing the cover” on page 357).
9. Slide the server into the rack.
10. Reconnect the power cord and any cables that you removed.
11. Turn on the peripheral devices and the server.

Removing a ServeRAID SAS/SATA controller from the SAS/SATA RAID riser card

Use this information to remove a ServeRAID SAS/SATA controller from the SAS/SATA RAID riser card.

About this task

A ServeRAID SAS/SATA controller is installed in a dedicated slot on the SAS/SATA RAID riser card.

Depending on the server model, the server comes with a ServeRAID-BR10il v2, ServeRAID-M1015, ServeRAID-M5014, or a ServeRAID-M5015 SAS/SATA adapter installed.

You can replace the ServeRAID controller with another supported ServeRAID controller. For a list of supported ServeRAID controllers, see <http://www.ibm.com/systems/info/x86servers/serverproven/compat/us/>.

Note: For brevity, in this documentation the ServeRAID SAS/SATA controller is often referred to as the *SAS/SATA adapter* or the *ServeRAID adapter*.

To remove the SAS/SATA adapter from a SAS/SATA RAID riser card, complete the following steps:

Procedure

1. Read the safety information that begins on “Safety” on page vii and “Installation guidelines” on page 347.
2. Turn off the server and peripheral devices and disconnect all power cords.
3. Remove the cover (see “Removing the cover” on page 356).
4. Locate the SAS/SATA RAID riser card and controller assembly near the left-front corner of the server.
5. Disconnect the SAS signal cables from the connectors on the SAS/SATA adapter and note their locations.
6. Remove the SAS/SATA RAID riser card from the server (see “Removing the SAS/SATA RAID riser-card assembly” on page 385).

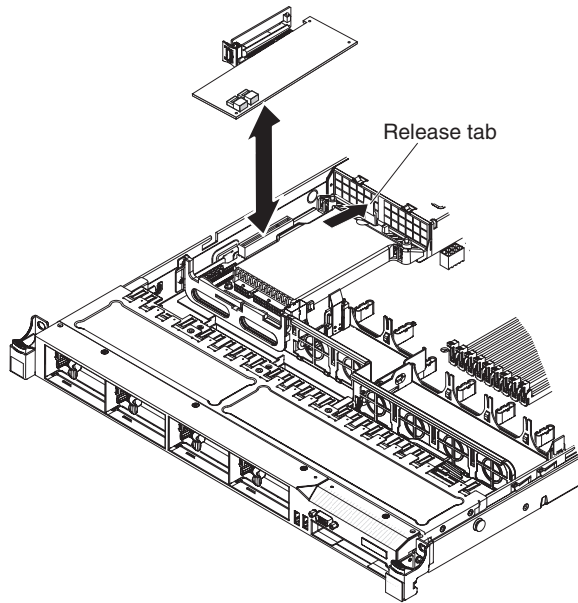

Figure 56. SAS/SATA RAID riser-card assembly removal

7. Pull the SAS/SATA adapter horizontally out of the connector on the SAS/SATA RAID riser card.

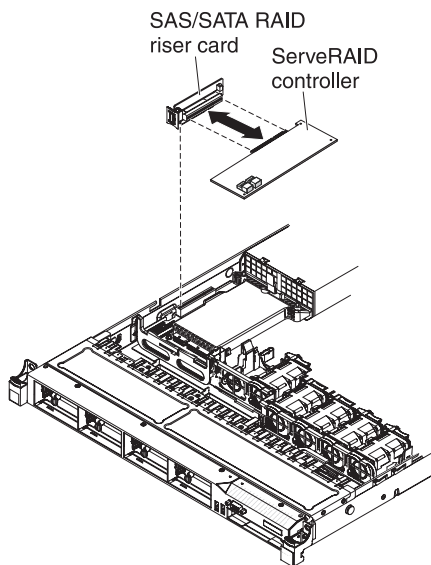

Figure 57. ServeRAID controller removal

Note: If you have installed the optional ServeRAID adapter advanced feature key, remove it and keep it in future use (see “Removing an optional ServeRAID adapter advanced feature key” on page 392).

Results

If you are instructed to return the SAS/SATA adapter, follow all packaging instructions, and use any packaging materials for shipping that are supplied to you.

Installing a ServeRAID SAS/SATA controller on the SAS/SATA RAID riser card

Use this information to install a ServeRAID SAS/SATA controller on the SAS/SATA RAID riser card.

About this task

To install a SAS/SATA adapter on the SAS/SATA RAID riser card, complete the following steps:

Procedure

1. Read the safety information that begins on “Safety” on page vii and “Installation guidelines” on page 347.
2. Turn off the server and peripheral devices and disconnect all power cords.
3. Remove the cover (see “Removing the cover” on page 356).
4. If you are installing a new or replacement SAS/SATA adapter, touch the static-protective package that contains the new SAS/SATA adapter to any unpainted metal surface on the server. Then, remove the new SAS/SATA adapter from the package.

Note: If you have the optional ServeRAID adapter advanced feature key, install it first (see “Installing an optional ServeRAID adapter advanced feature key” on page 394).

5. Align the SAS/SATA adapter so that the keys align correctly with the connector on the SAS/SATA RAID riser-card assembly.

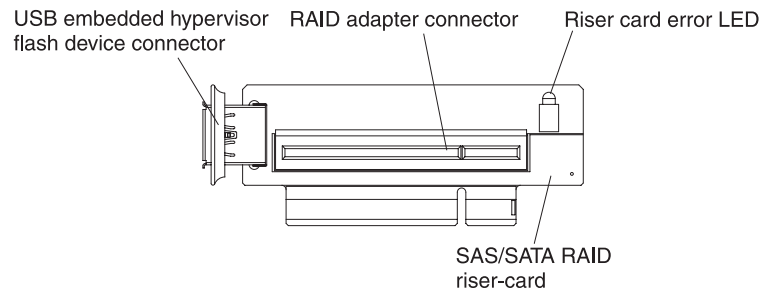

Figure 58. RAID adapter connector

6. Insert the SAS/SATA adapter into the connector on the SAS/SATA RAID riser card until it is firmly seated.

Attention: Incomplete insertion might cause damage to the server or the adapter.

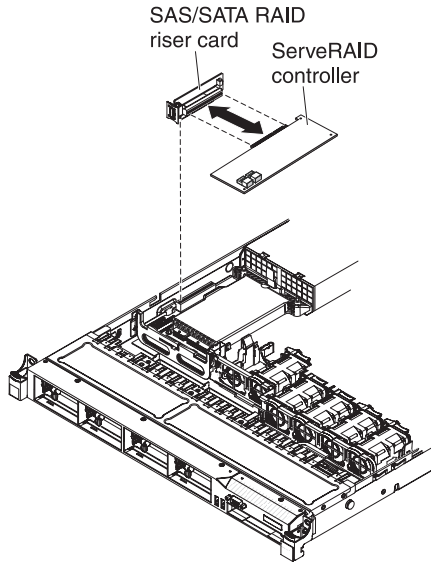

Figure 59. ServeRAID controller installation

7. Install the SAS/SATA RAID riser-card assembly (see “Installing the SAS/SATA RAID riser-card assembly” on page 386).
8. Route the signal cables from the drive backplane over the blue adapter retention bracket.
9. Connect the signal cables to the SAS/SATA adapter:
 - **ServeRAID-BR10il v2 adapter:** Take the signal cable that is attached to the drive backplane for drive bays 0 through 3 and connect it to the SAS/SATA connector on the ServeRAID adapter.

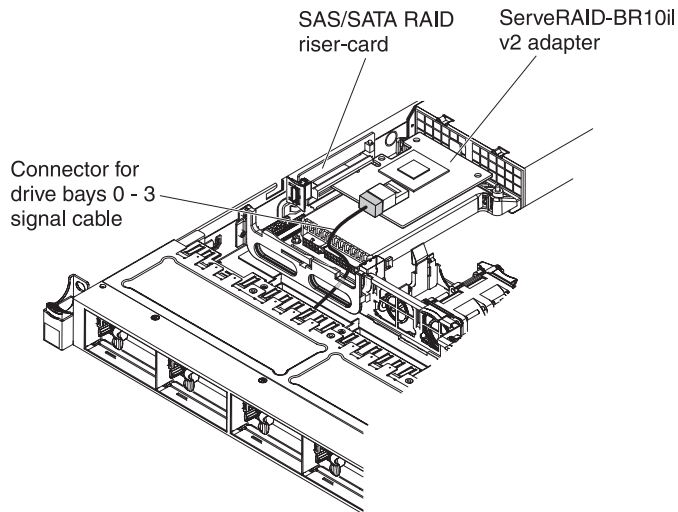

Figure 60. ServeRAID-BR10il v2 adapter cable connection

- **ServeRAID-BR10i, ServeRAID-M1015, ServeRAID-M5014, or ServeRAID-M5015 adapter:** Take the signal cable that is attached to the drive backplane for drive bays 4 through 7 and connect it to the ServeRAID adapter connector that is closest to the power supply cage. Connect the other signal cable so that is attached to the drive backplane for drive bays 0

through 3 and connect it to the other connector on the adapter.

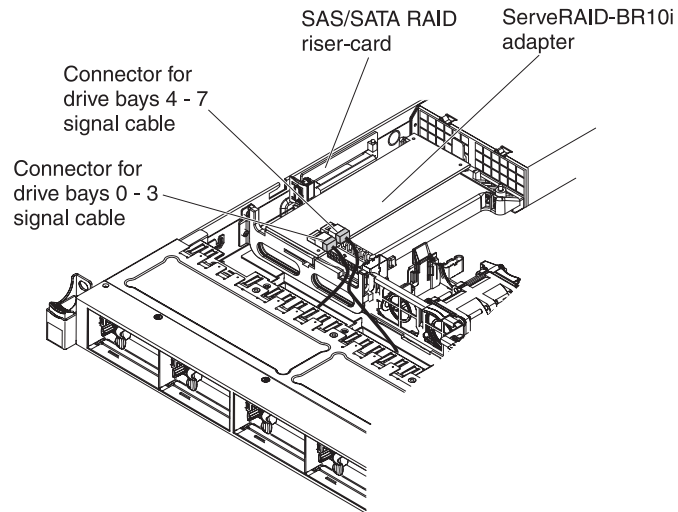

Figure 61. ServeRAID-BR10i adapter cable connection

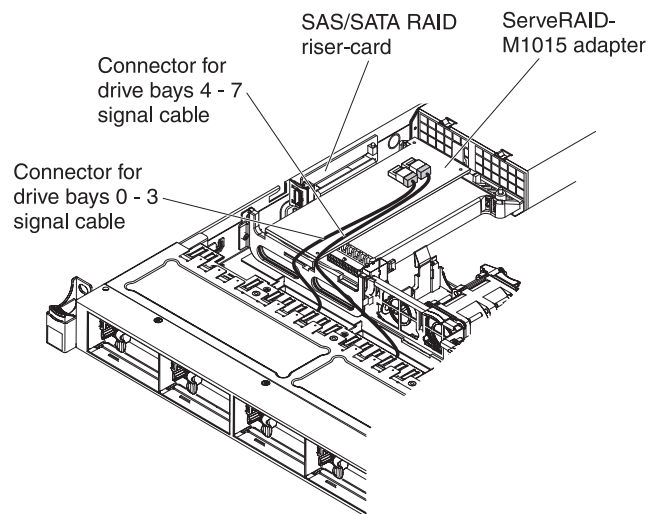

Figure 62. ServeRAID-M5015 adapter cable connection

- **ServeRAID-M10i adapter:** Take the signal cable that is attached to the drive backplane for drive bays 0 through 3 and connect it to the connector on the ServeRAID adapter connector that is closest to the power-supply cage. Connect the other signal cable so that is attached to the drive backplane for drive bays 4 and 7 and connect it to the other connector on the adapter.

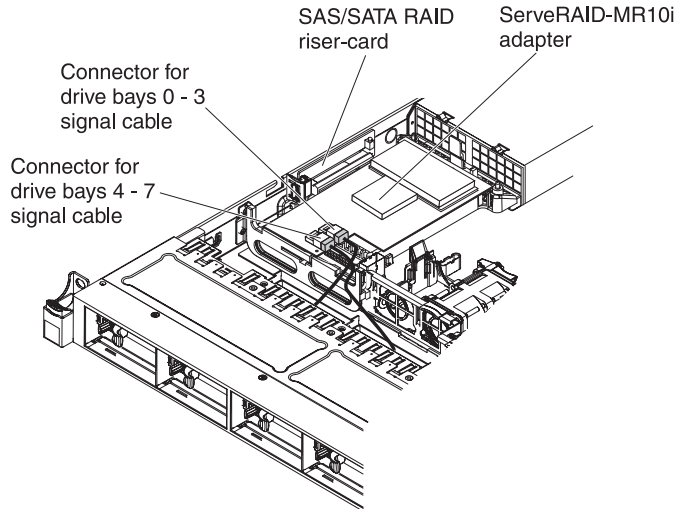

Figure 63. ServeRAID-M10i adapter cable connection

10. Reconnect the power cord and any cables that you removed.
11. Replace the cover (see "Installing the cover" on page 357).
12. Turn on the peripheral devices and the server.

Note: When you restart the server, you are prompted to import the existing RAID configuration to the new SAS/SATA adapter.

Removing an optional ServeRAID adapter advanced feature key

Use this information to remove an optional ServeRAID adapter advanced feature key.

About this task

To remove an optional ServeRAID adapter advanced feature key, complete the following steps:

Procedure

1. Read the safety information that begins on "Safety" on page vii and "Installation guidelines" on page 347.
2. Turn off the server and peripheral devices and disconnect all power cords.
3. Remove the cover (see "Removing the cover" on page 356).
4. Grasp the feature key and lift to remove it from connector on the ServeRAID adapter.

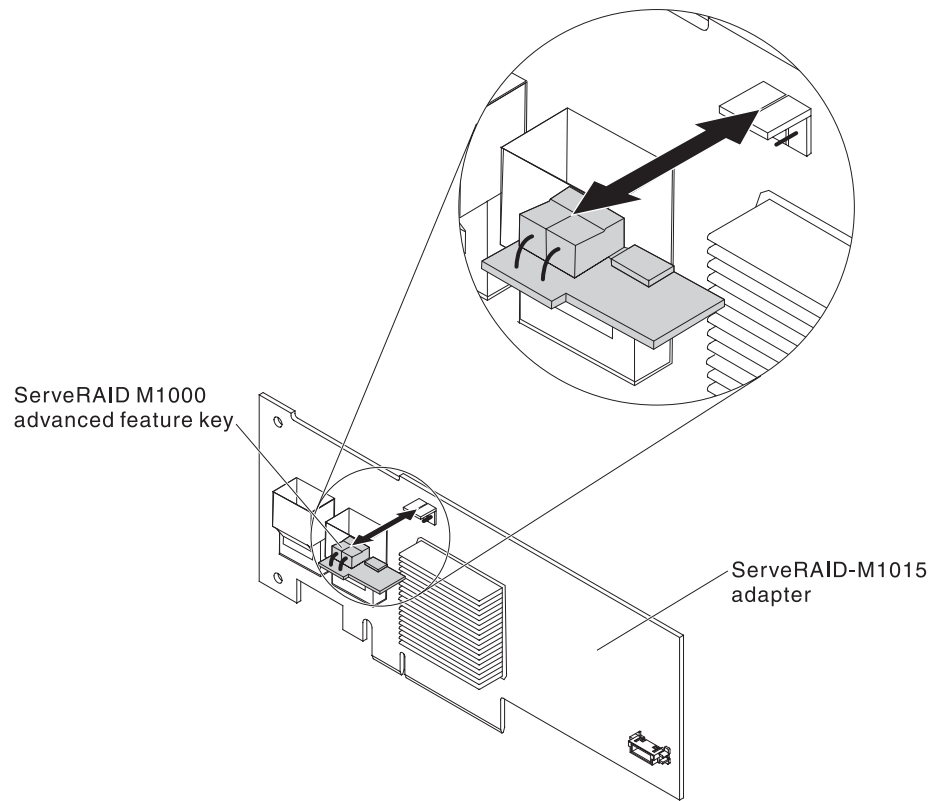

Figure 64. ServeRAID M1000 advanced feature key removal

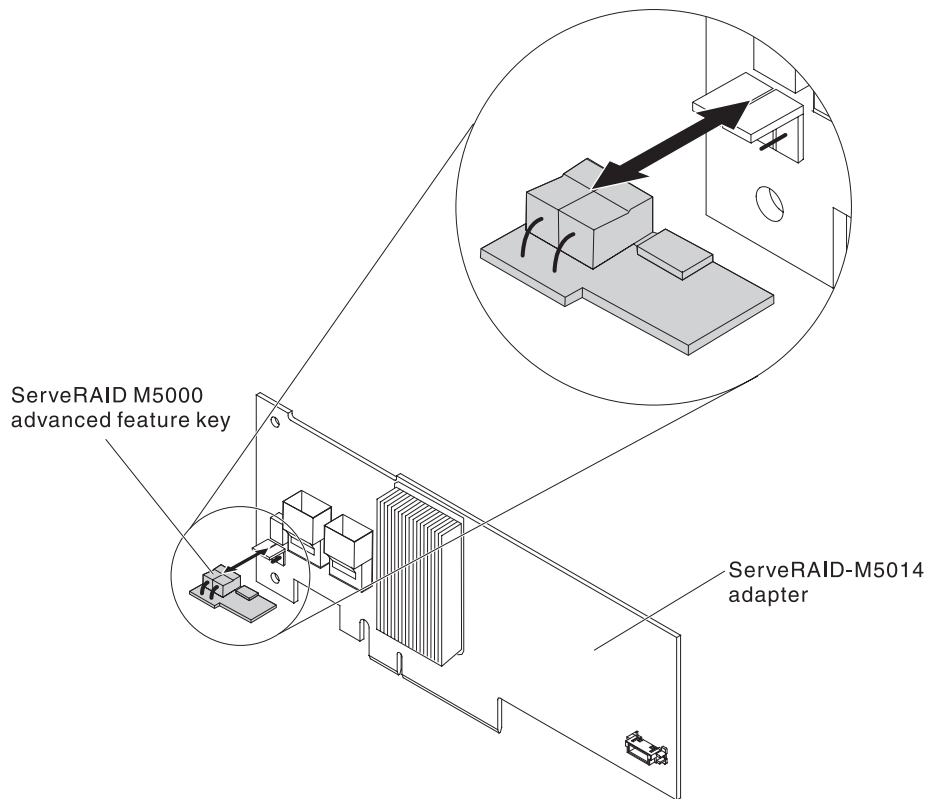

Figure 65. ServeRAID M5000 advanced feature key removal

Results

If you are instructed to return the feature key, follow all packaging instructions, and use any packaging materials for shipping that are supplied to you.

Installing an optional ServeRAID adapter advanced feature key

Use this information to install an optional ServeRAID adapter advanced feature key.

About this task

To install an optional ServeRAID adapter advanced feature key, complete the following steps:

Procedure

1. Read the safety information that begins on "Safety" on page vii and "Installation guidelines" on page 347.
2. Turn off the server and peripheral devices and disconnect all power cords.
3. Remove the cover (see "Removing the cover" on page 356).
4. Align the feature key with the connector on the ServeRAID adapter and push it into the connector until it is firmly seated.

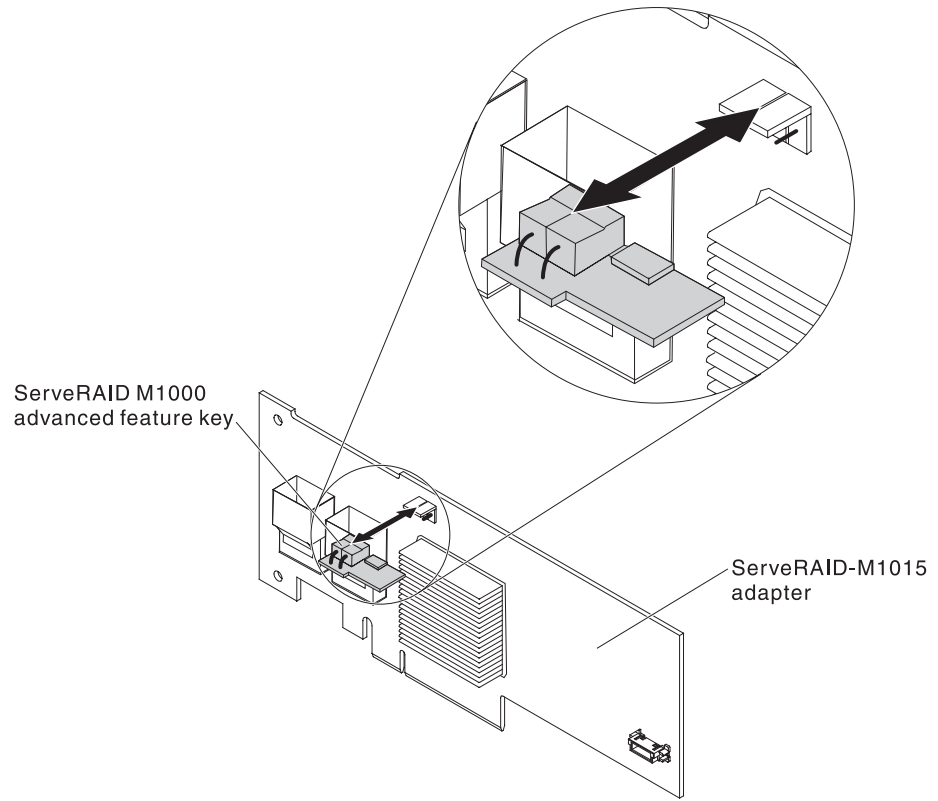

Figure 66. ServeRAID M1000 advanced feature key installation

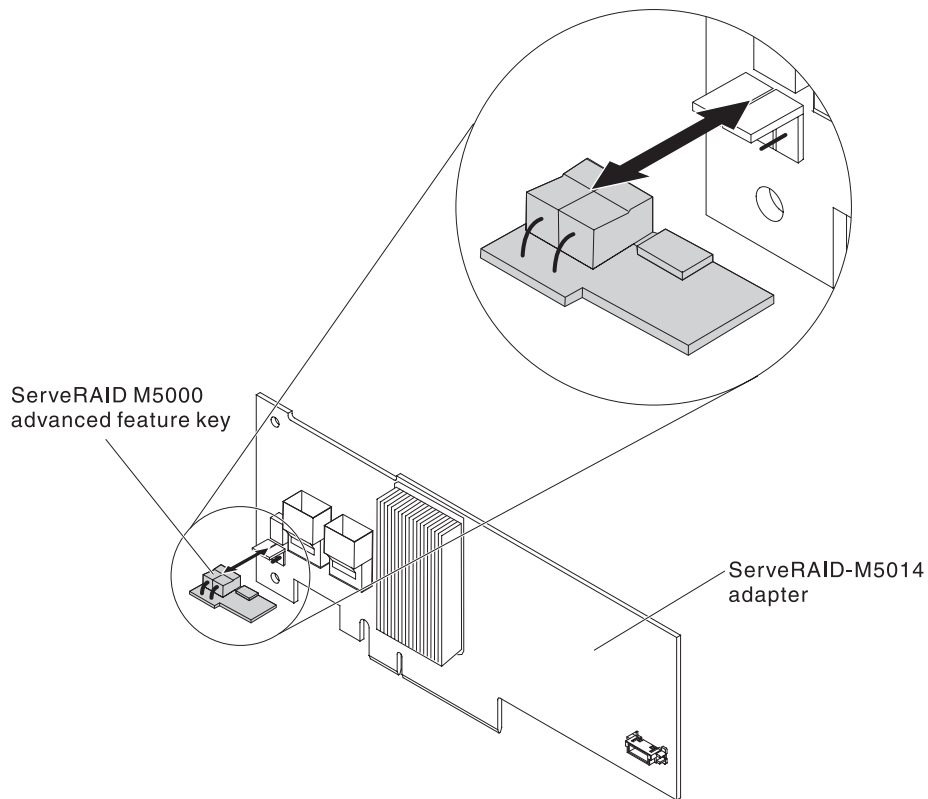

Figure 67. ServeRAID M5000 advanced feature key installation

5. Reconnect the power cord and any cables that you removed.
6. Install the cover (see "Installing the cover" on page 357).
7. Slide the server into the rack.
8. Turn on the peripheral devices and the server.

Removing a hot-swap fan assembly

Use this information to remove a hot-swap fan assembly.

About this task

Attention: To ensure proper server operation, replace a failed hot-swap fan within 30 seconds.

To remove a hot-swap-fan, complete the following steps:

Procedure

1. Read the safety information that begins on "Safety" on page vii and "Installation guidelines" on page 347.
2. Remove the cover (see "Removing the cover" on page 356).

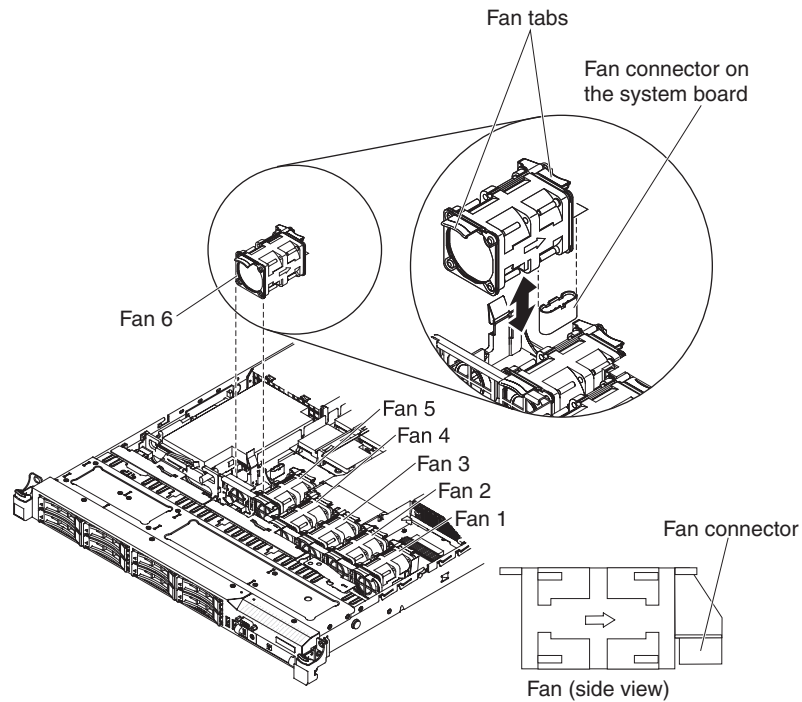

Figure 68. Fan removal

Note: The LED near the connector of the failing fan assembly is lit.

3. Grasp the orange fan tabs on both ends of the existing fan and pull it up out of the server. If you are removing fans 3 or 4, lift up the clear tab on the DIMM air baffle first.

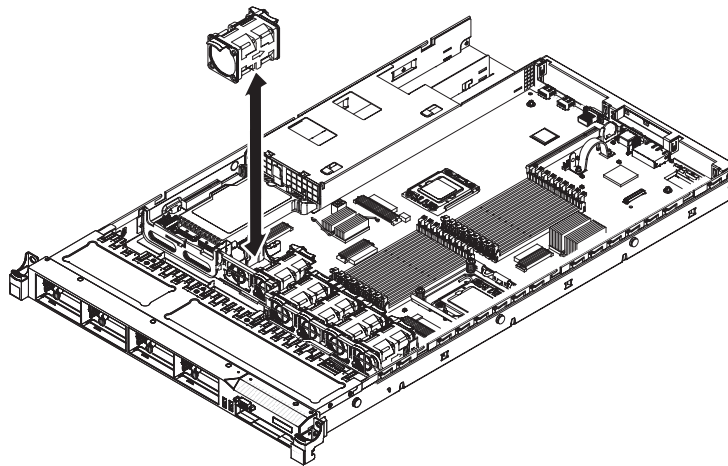

Figure 69. Fan removal

Attention: To ensure proper operation, replace a failed hot-swap fan within 30 seconds.

Results

If you are instructed to return the fan, follow all of the packaging instructions, and use any packaging materials for shipping that are supplied to you.

Installing a hot-swap fan assembly

Use this information to install a hot-swap fan assembly.

About this task

The server comes standard with five dual-motor hot-swap cooling fans.

Attention: To ensure proper operation, replace a failed hot-swap fan within 30 seconds.

To install an additional hot-swap fan, complete the following steps:

Procedure

1. Read the safety information that begins on “Safety” on page vii and “Installation guidelines” on page 347.
2. Remove the cover (see “Removing the cover” on page 356).
3. Touch the static-protective package that contains the new fan to any unpainted metal surface on the server. Then, remove the new fan from the package.

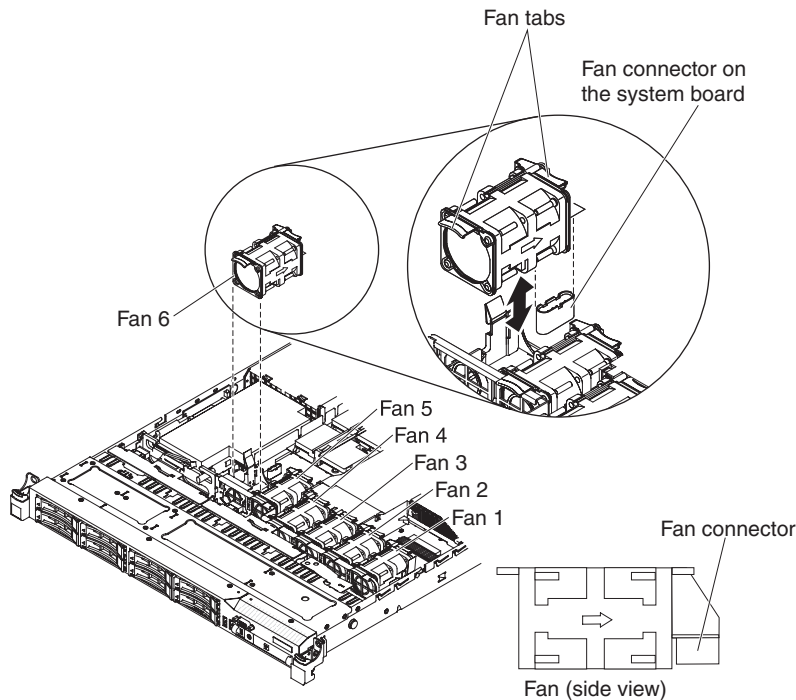

Figure 70. Fan installation

4. Orient the fan over the fan slot in the fan assembly bracket so that the fan connector aligns with the connector on the system board.

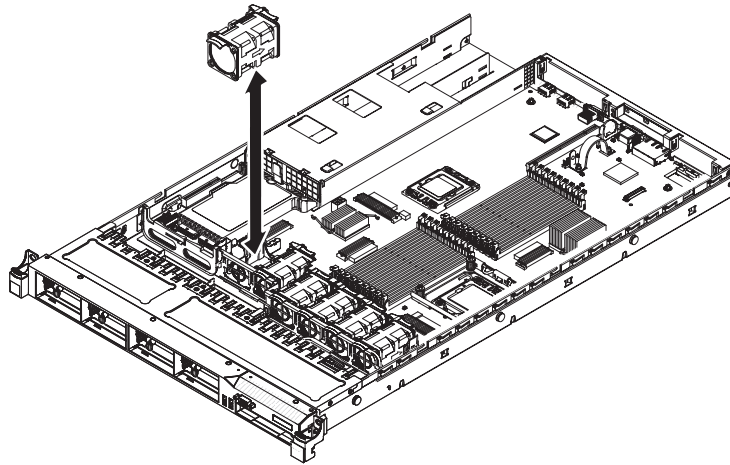

Figure 71. Fan installation

5. Insert the fan into the fan slot in the fan assembly bracket and press it down until it is seated correctly in the slot and the fan connector is seated correctly in the connector on the system board.
6. Install the cover (see “Installing the cover” on page 357).
7. Slide the server into the rack.

Removing a hot-swap ac power supply

Use this information to remove a hot-swap ac power supply.

About this task

When you remove or install a hot-swap power supply, observe the following precautions.

Statement 5



CAUTION:

The power control button on the device and the power switch on the power supply do not turn off the electrical current supplied to the device. The device also might have more than one power cord. To remove all electrical current from the device, ensure that all power cords are disconnected from the power source.

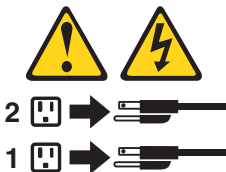

Statement 8



CAUTION:

Never remove the cover on a power supply or any part that has the following label attached.



Hazardous voltage, current, and energy levels are present inside any component that has this label attached. There are no serviceable parts inside these components. If you suspect a problem with one of these parts, contact a service technician.

Note: The procedure below describes how to remove a hot-swap ac power supply, for instructions on how to remove a hot-swap dc power supply, refer to the documentation that comes with the dc power supply.

To remove a hot-swap ac power supply, complete the following steps:

Procedure

1. Read the safety information that begins on “Safety” on page vii and “Installation guidelines” on page 347.
2. If only one power supply is installed, turn off the server and peripheral devices and disconnect all power cords.
3. If the server is in a rack, at the back of the server, pull back the cable management arm to gain access to the rear of the server and the power supply.
4. Press and hold the release tab to the left. Grasp the handle and pull the power supply out of the server.

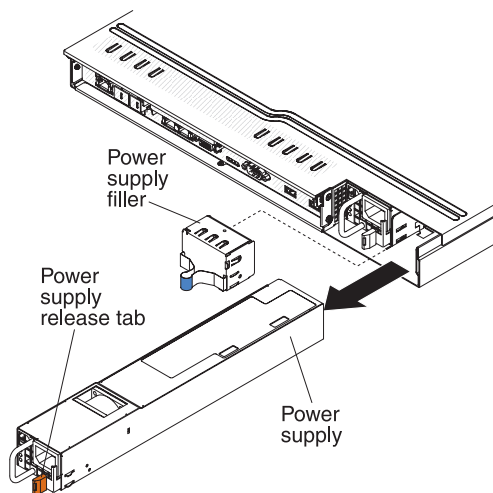

Figure 72. Power supply removal

Results

If you are instructed to return the power supply, follow all packaging instructions, and use any packaging materials for shipping that are supplied to you.

Installing a hot-swap ac power supply

Use this information to install a hot-swap ac power supply.

About this task

The following notes describe the type of power supply that the server supports and other information that you must consider when you install a power supply:

- Before you install an additional power supply or replace a power supply with one of a different wattage, you may use the IBM Power Configurator utility to determine current system power consumption. For more information and to download the utility, go to <http://www.ibm.com/systems/bladecenter/resources/powerconfig.html>.
- The server comes with one hot-swap 12-volt output power supply that connects to power supply bay 1. The input voltage is 110 V ac or 220 V ac auto-sensing.
- You cannot mix 460-watt and 675-watt power supplies, high-efficiency and non-high-efficiency power supplies, or ac and dc power supplies in the server.
- The following information applies when you install 460-watt power supplies in the server:
 - A warning message is generated if the total power consumption exceeds 400 watts and the server only has one operational 460-watt power supply. In this case, the server can still operate under normal condition. Before you install additional components in the server, you must install an additional power supply
 - The server automatically shuts down if the total power consumption exceeds the total power supply output capacity
 - You can enable the power capping feature in the Setup utility to control and monitor power consumption in the server (see “Setup utility menu choices” on page 461).

The following table shows the system status when you install 460-watt power supplies in the server:

Table 21. System status with 460-watt power supplies installed

Total system power consumption (in watts)	Number of 460-watt power supplies installed		
	One	Two	Two with one failure
< 400	Normal	Normal, redundant power	Normal
400 ~ 460	Normal, status warning	Normal, redundant power	Normal, status warning
> 460	System shutdown	Normal	System shutdown

- Power supply 1 is the default/primary power supply. If power supply 1 fails, you must replace the power supply immediately.
- You can order an optional power supply for redundancy.
- These power supplies are designed for parallel operation. In the event of a power-supply failure, the redundant power supply continues to power the system. The server supports a maximum of two power supplies.
- For instructions on how to install a hot-swap dc power supply, refer to the documentation that comes with the dc power supply.

Statement 5



CAUTION:

The power control button on the device and the power switch on the power supply do not turn off the electrical current supplied to the device. The device also might have more than one power cord. To remove all electrical current from the device, ensure that all power cords are disconnected from the power source.

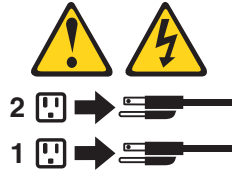

Statement 8



CAUTION:

Never remove the cover on a power supply or any part that has the following label attached.



Hazardous voltage, current, and energy levels are present inside any component that has this label attached. There are no serviceable parts inside these components. If you suspect a problem with one of these parts, contact a service technician.

To install a hot-swap ac power supply, complete the following steps:

Procedure

1. Read the safety information that begins on “Safety” on page vii and “Installation guidelines” on page 347.
2. Touch the static-protective package that contains the hot-swap power supply to any unpainted metal surface on the server; then, remove the power supply from the package and place it on a static-protective surface.
3. If you are installing a hot-swap power supply into an empty bay, remove the power-supply filler panel from the power-supply bay.

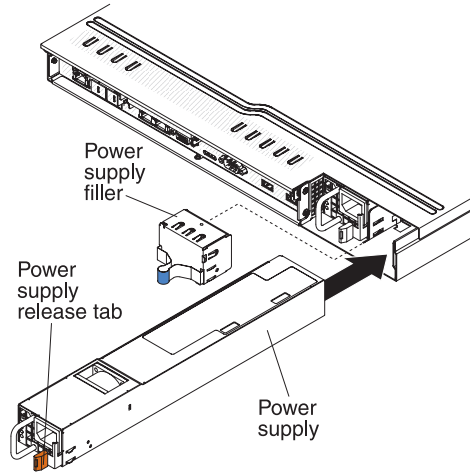

Figure 73. Power supply installation

4. Grasp the handle on the rear of the power supply and slide the power supply forward into the power-supply bay until it clicks. Make sure that the power supply connects firmly into the power-supply connector.

Attention: Do not install 460-watt and 675-watt power supplies, high-efficiency and non-high-efficiency power supplies, or ac and dc power supplies in the server.
5. Route the power cord through the handle so that it does not accidentally become unplugged.
6. Connect the power cord for the new power supply to the power-cord connector on the power supply.
7. Connect the other end of the power cord to a properly grounded electrical outlet.
8. Make sure that the ac power LED and the dc power LED on the ac power supply are lit, indicating that the power supply is operating correctly. The two green LEDs are to the right of the power-cord connector.
9. If you are replacing a power supply with one of a different wattage, apply the power information label provided with the new power supply over the existing power information label on the server.

额定电压 xxx-xxx/xxx-xxx	额定电压
额定电流 x.x/x.x	额定电流
额定频率 xx/xx HZ	额定频率



Figure 74. Power information label

Removing a USB embedded hypervisor flash device

Use this information to remove a USB embedded hypervisor flash device.

About this task

To remove a hypervisor flash device, complete the following steps:

Procedure

1. Read the safety information that begins on “Safety” on page vii and “Installation guidelines” on page 347.
2. Turn off the server and peripheral devices and disconnect the power cords.
3. Remove the cover (see “Removing the cover” on page 356).
4. Grasp the flash device blue lockbar (shown in the following illustration) and slide it toward the SAS/SATA riser-card assembly to the unlock position and remove it from the connector.

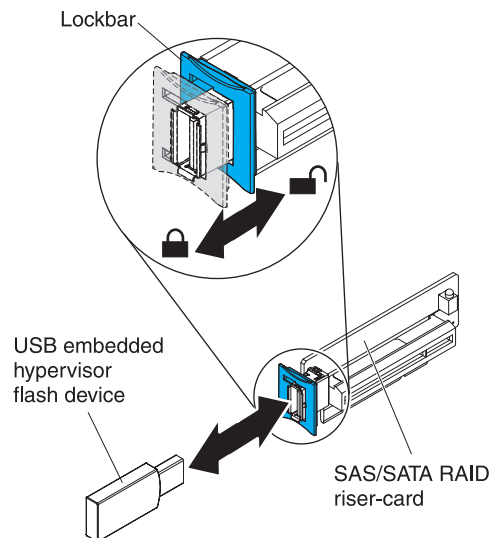

Figure 75. USB embedded hypervisor flash device removal

Results

If you are instructed to return the flash device, follow all packaging instructions, and use any packaging materials for shipping that are supplied to you.

Installing a USB embedded hypervisor flash device

Use this information to install a USB embedded hypervisor flash device.

About this task

To install a hypervisor flash device, complete the following steps:

Procedure

1. Read the safety information that begins on “Safety” on page vii and “Installation guidelines” on page 347.
2. Turn off the server and peripheral devices and disconnect the power cords.
3. Remove the cover (see “Removing the cover” on page 356).
4. Align the flash device with the connector on the SAS/SATA RAID riser-card assembly and push it into the connector until it is firmly seated.
5. Slide the blue lockbar toward the flash device to the locked position until it is seated firmly.

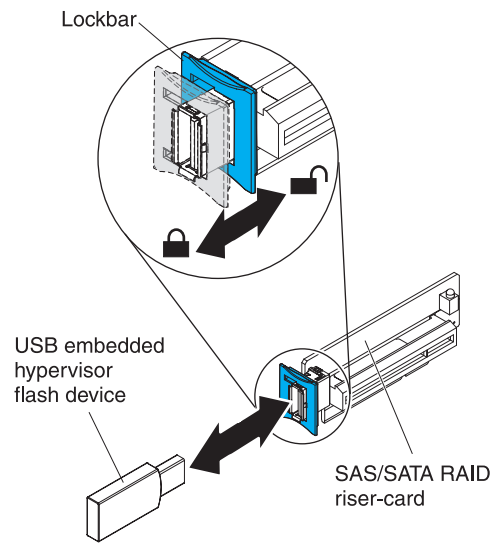

Figure 76. USB embedded hypervisor flash device installation

6. Reconnect the power cord and any cables that you removed.
7. Install the cover (see “Installing the cover” on page 357).
8. Slide the server into the rack.
9. Turn on the peripheral devices and the server.

Removing the virtual media key

Use this information to remove the virtual media key.

About this task

To remove the virtual media key, complete the following steps:

Procedure

1. Read the safety information that begins on “Safety” on page vii and “Installation guidelines” on page 347.
2. Turn off the server and peripheral devices and disconnect the power cords.
3. Remove the cover (see “Removing the cover” on page 356).
4. Grasp the virtual media key and gently slide it up and off of the mounting tab.

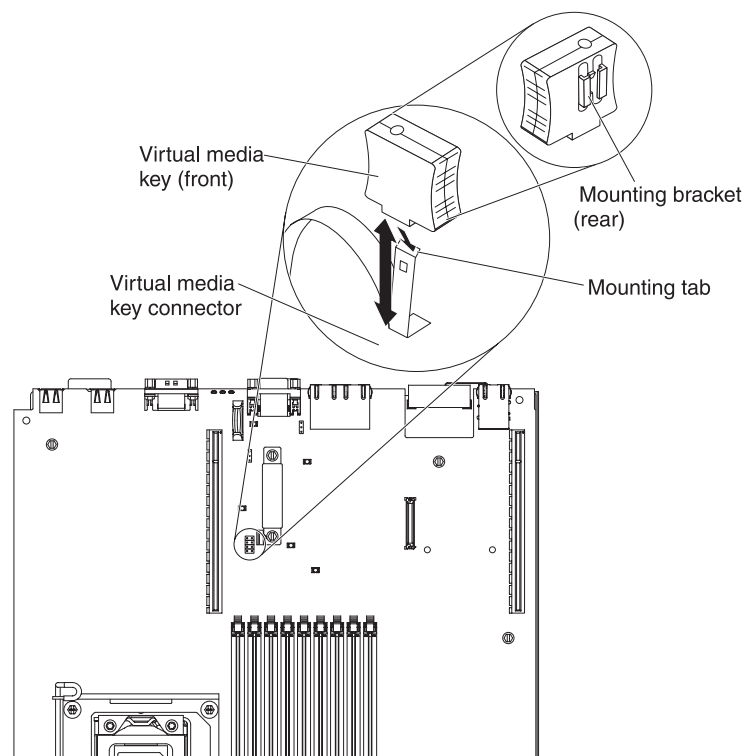

Figure 77. Virtual media key removal

Results

If you are instructed to return the virtual media key, follow all packaging instructions, and use any packaging materials for shipping that are supplied to you.

Installing the virtual media key

Use this information to install the virtual media key.

About this task

To install the virtual media key, complete the following steps:

Procedure

1. Read the safety information that begins on “Safety” on page vii and “Installation guidelines” on page 347.
2. Turn off the server and peripheral devices and disconnect the power cords.
3. Remove the cover (see “Removing the cover” on page 356).
4. Align the virtual media key with the mounting tab and slide it down the tab onto the connector on the system board. Press the virtual media key down into the connector until it is firmly seated on the system board.

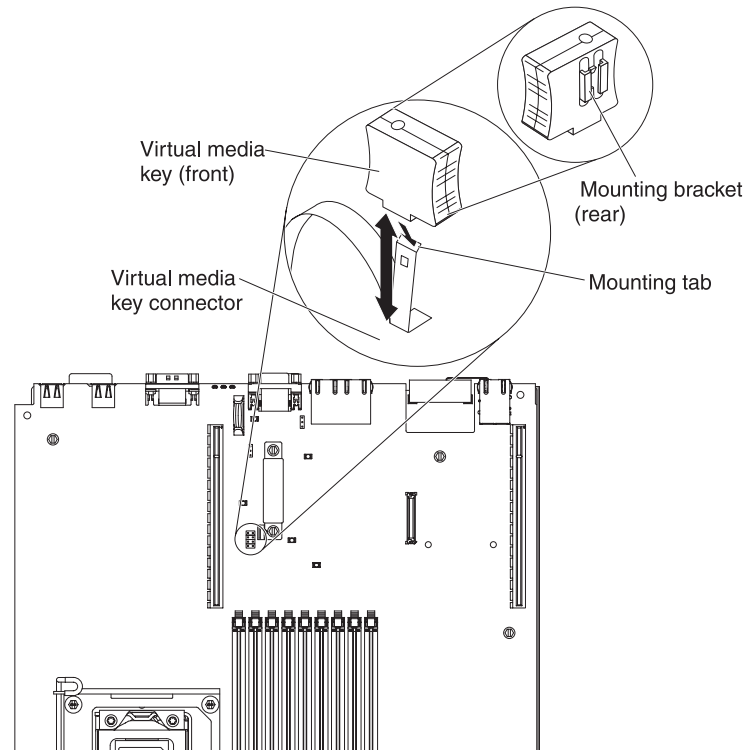

Figure 78. Virtual media key installation

5. Replace the cover (see “Installing the cover” on page 357).
6. Slide the server into the rack.
7. Reconnect the power cord and any cables that you removed.
8. Turn on the peripheral devices and the server.

Removing the optional two-port Ethernet adapter

Use this information to remove the optional two-port Ethernet adapter.

About this task

To remove the Ethernet adapter, complete the following steps:

Procedure

1. Read the safety information that begins on “Safety” on page vii and “Installation guidelines” on page 347.
2. Turn off the server and peripheral devices and disconnect the power cords.
3. Remove the cover (see “Removing the cover” on page 356).
4. Remove the PCI riser-card assembly (if installed) from PCI riser connector 1 (see “Removing a PCI riser-card assembly” on page 425).
5. Grasp the Ethernet adapter and disengage it from the standoffs and the connector on the system board; then, slide the Ethernet adapter out of the port openings on the rear of the chassis and remove it from the server.

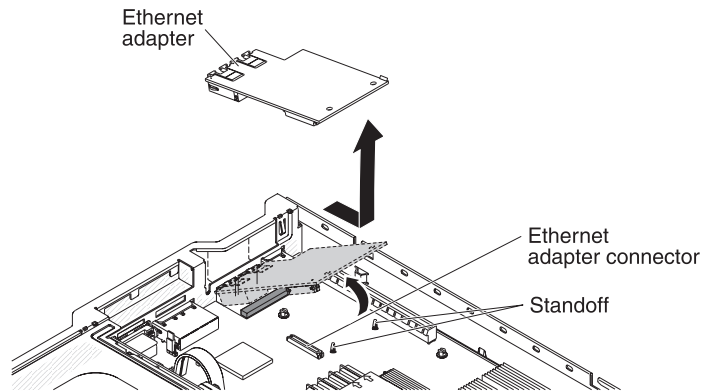

Figure 79. Ethernet adapter removal

Results

If you are instructed to return the Ethernet adapter, follow all packaging instructions, and use any packaging materials for shipping that are supplied to you.

Installing the optional two-port Ethernet adapter

Use this information to install the optional two-port Ethernet adapter.

About this task

To install the Ethernet adapter, complete the following steps:

Procedure

1. Read the safety information that begins on “Safety” on page vii and “Installation guidelines” on page 347.
2. Turn off the server and peripheral devices and disconnect the power cords.
3. Remove the cover (see “Removing the cover” on page 356).
4. Remove the PCI riser-card assembly (if installed) from PCI riser connector 1 (see “Removing a PCI riser-card assembly” on page 425).
5. Attach the rubber stopper on the chassis, along the edge of the system board, as shown in the following illustration.

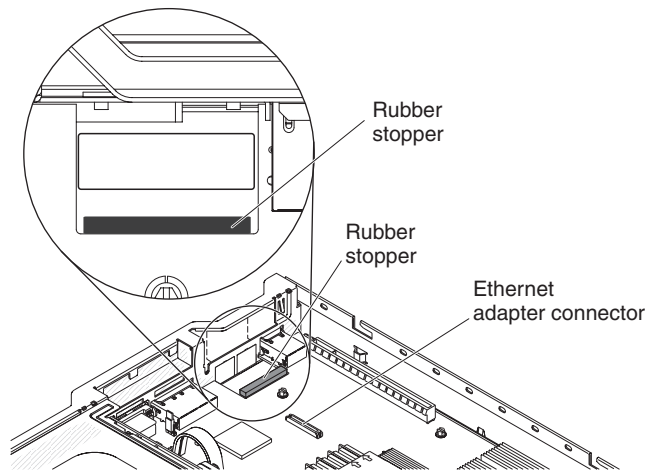

Figure 80. Rubber stopper

6. Remove the adapter filler panel on the rear of the chassis (if it has not been removed already).

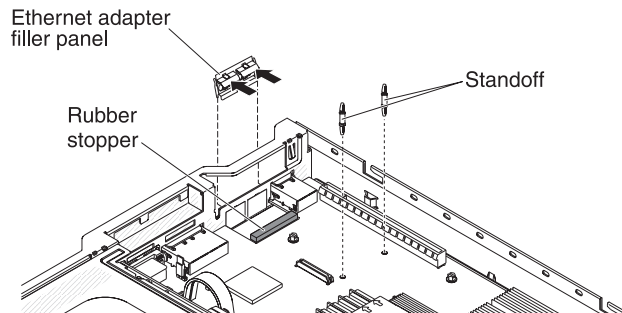

Figure 81. Filler panel removal

7. Install the two standoffs on the system board.

8. Insert the bottom tabs of the metal clip into the port openings from outside the chassis.

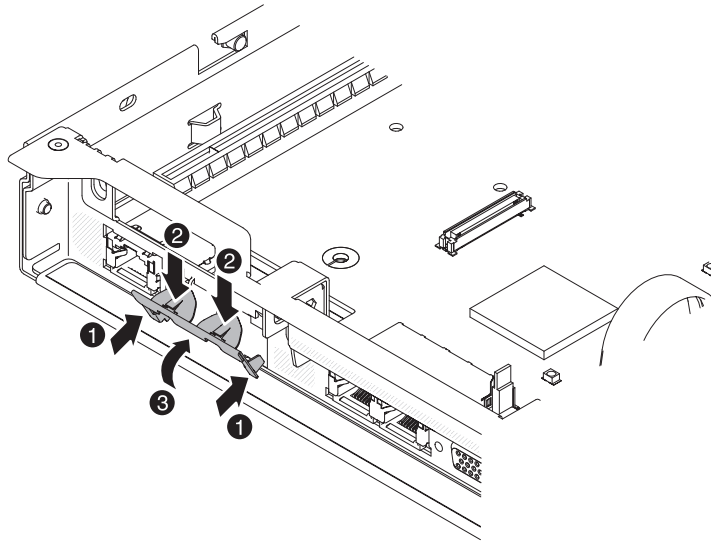

Figure 82. Metal clip installation

9. While you slightly press the top of the metal clip, rotate the metal clip toward the front of the server until the metal clip clicks into place. Make sure the metal clip is securely engaged on the chassis.

Attention: Pressing the top of the metal clip with excessive force may cause damage to the metal clip.

10. Touch the static-protective package that contains the new adapter to any unpainted metal surface on the server. Then, remove the adapter from the package.
11. Align the adapter with the adapter connector on the system board; then, tilt the adapter so that the port connectors on the adapter line up with the port openings on the chassis.

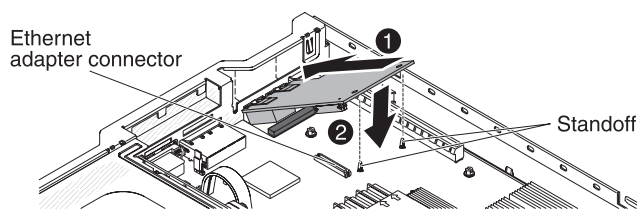

Figure 83. Adapter installation

12. Slide the port connectors on the adapter into the port openings on the chassis; then, press the adapter firmly until the two standoffs engage the adapter. Make sure the adapter is securely seated on the connector on the system board. Make sure the port connectors on the adapter do not set on the rubber stopper. The following illustration shows the side view of the adapter in the server.

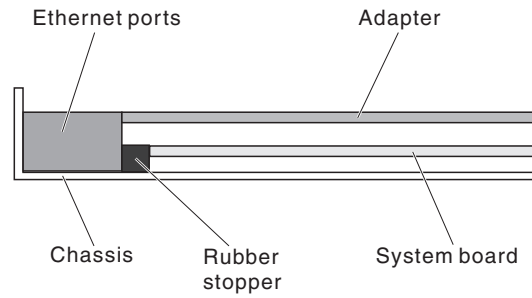

Figure 84. Adapter installation

Attention: Make sure the port connectors on the adapter are aligned properly with the chassis on the rear of the server. An incorrectly seated adapter might cause damage to the system board or the adapter.

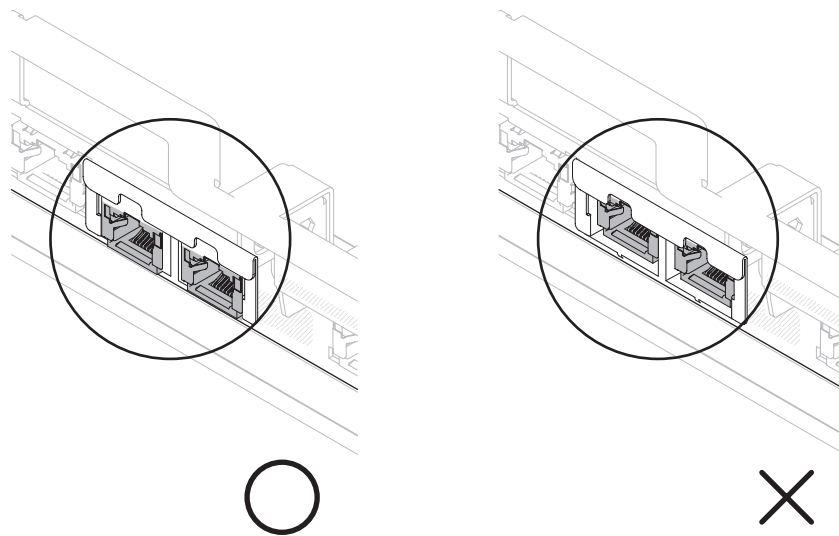

Figure 85. Port connectors

13. Reinstall the PCI riser-card assembly in PCI riser connector 1 if you have removed it previously (see “Installing a PCI riser-card assembly” on page 426).
14. Replace the cover (see “Installing the cover” on page 357).
15. Slide the server into the rack.
16. Reconnect the power cords and any cables that you removed.
17. Turn on the peripheral devices and the server.

Removing a remotely installed RAID adapter battery

Use this information to remove a remotely installed RAID adapter battery.

About this task

If a RAID adapter battery is installed remotely on the microprocessor 2 air baffle and you need to replace it, complete the following steps:

Procedure

1. Read the safety information that begins on "Safety" on page vii and "Installation guidelines" on page 347.
2. Turn off the server and peripheral devices and disconnect the power cords.
3. Remove the cover (see "Removing the cover" on page 356).
4. From the top of the microprocessor 2 air baffle, remove the battery retention clip that holds the battery in place. Press the release tab toward the front of the server and remove the battery retention clip.

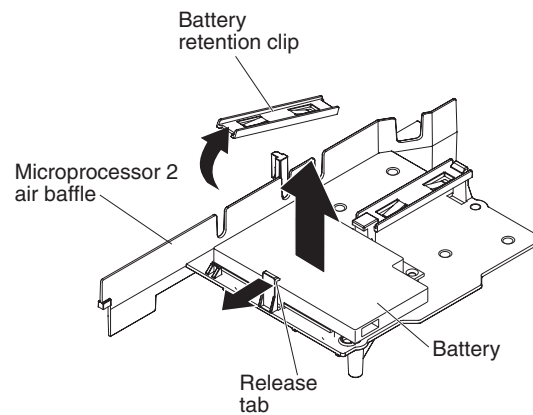

Figure 86. Battery removal

5. Disconnect the remote battery cable from the remote battery cable connector on the battery carrier and lift the battery and battery carrier from the slot. See the following illustration for the location of the connectors on the battery carrier.

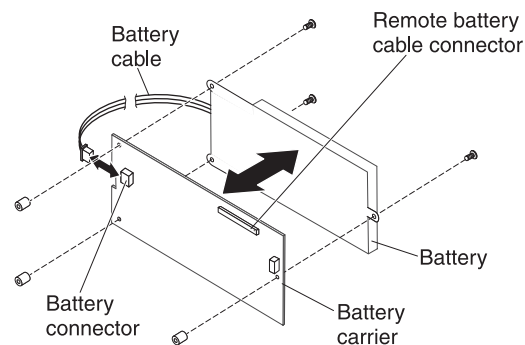

Figure 87. Battery removal

6. Disconnect the battery cable from the battery cable connector on the battery carrier.
7. Remove the three screws that attach the battery carrier to the battery and remove the battery from the battery carrier.

Note: If your battery and battery carrier are attached with a clip, squeeze the clip on the side of the battery carrier to remove the battery from the battery carrier.

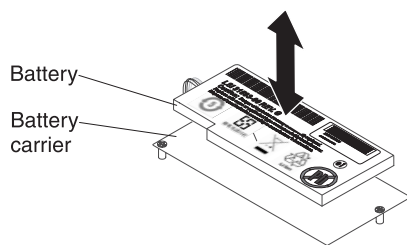

Figure 88. Battery removal

Results

If you are instructed to return the RAID adapter battery, follow all packaging instructions, and use any packaging materials for shipping that are supplied to you.

Installing a RAID adapter battery remotely in the server

Use this information to install a RAID adapter battery remotely in the server.

About this task

The batteries must be installed only on top of the microprocessor 2 air baffle. To install the RAID adapter battery in the server, complete the following steps:

Procedure

1. Read the safety information that begins on “Safety” on page vii and “Installation guidelines” on page 347.
2. Turn off the server and peripheral devices and disconnect the power cords.
3. Remove the cover (see “Removing the cover” on page 356).
4. Install the RAID adapter on the riser card and install the riser-card assembly in the server (see “Installing a PCI riser-card assembly” on page 426).
5. Route the remote battery cable through the notches on the microprocessor 2 air baffle.
Attention: Make sure that the cable is not pinched and does not cover any connectors or obstruct any components on the system board.
6. Install the battery on the microprocessor 2 air baffle:
 - a. Connect the battery cable to the battery cable connector on the battery carrier.

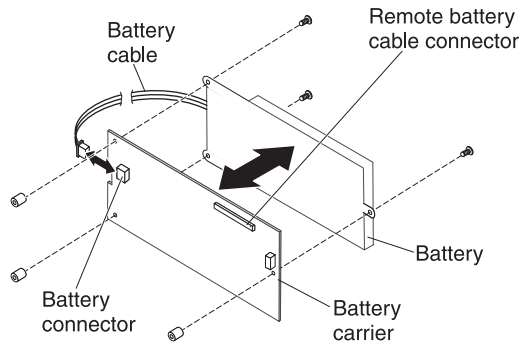

Figure 89. Battery installation

- b. Place the battery carrier in the battery mounting slot on the microprocessor 2 air baffle and ensure that battery carrier posts align with the rings on the battery mounting slot so that the battery carrier is secure in the slot.

Note: The positioning of the remote battery depends on the type of remote battery that you install.

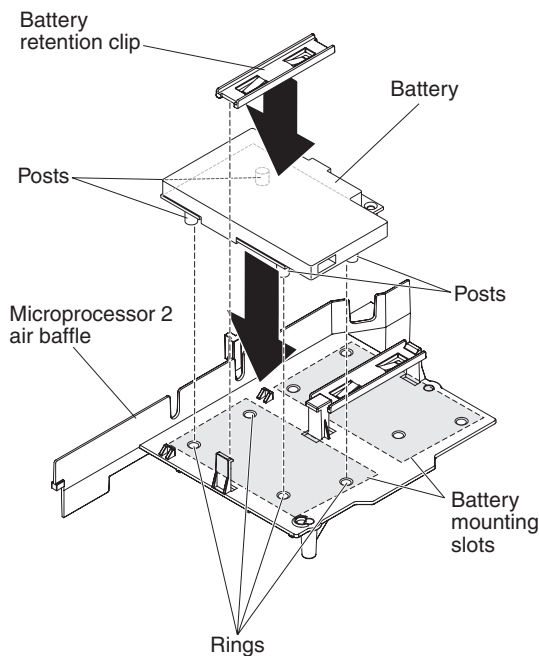

Figure 90. Battery installation

- c. Take the battery retention clip and place it underneath the other tab while pressing release tab toward the front of the server; then, press it down until it snaps in place to hold the battery carrier firmly in place.
7. Install the cover.
8. Slide the server into the rack.
9. Reconnect the power cords and all external cables, and turn on the server and peripheral devices.

Removing the system battery

Use this information to remove the system battery.

About this task

The following notes describe information that you must consider when replacing the battery:

- IBM has designed this product with your safety in mind. The lithium battery must be handled correctly to avoid possible danger. If you replace the battery, you must adhere to the following instructions.

Note: In the U. S., call 1-800-IBM-4333 for information about battery disposal.

- If you replace the original lithium battery with a heavy-metal battery or a battery with heavy-metal components, be aware of the following environmental consideration. Batteries and accumulators that contain heavy metals must not be disposed of with normal domestic waste. They will be taken back free of charge by the manufacturer, distributor, or representative, to be recycled or disposed of in a proper manner.
- To order replacement batteries, call 1-800-IBM-SERV within the United States, and 1-800-465-7999 or 1-800-465-6666 within Canada. Outside the U.S. and Canada, call your support center or business partner.

Note: After you replace the battery, you must reconfigure the server and reset the system date and time.

Statement 2



CAUTION:

When replacing the lithium battery, use only IBM Part Number 33F8354 or an equivalent type battery recommended by the manufacturer. If your system has a module containing a lithium battery, replace it only with the same module type made by the same manufacturer. The battery contains lithium and can explode if not properly used, handled, or disposed of.

Do not:

- Throw or immerse into water
- Heat to more than 100°C (212°F)
- Repair or disassemble

Dispose of the battery as required by local ordinances or regulations.

To remove the system-board battery, complete the following steps:

Procedure

1. Read the safety information that begins on “Safety” on page vii and “Installation guidelines” on page 347.
2. Turn off the server and peripheral devices and disconnect the power cords.
3. Remove the cover (see “Removing the cover” on page 356).

4. If necessary, lift the PCI riser-card assembly out of the way (see “Removing a PCI riser-card assembly” on page 425).
5. Remove the system-board battery:

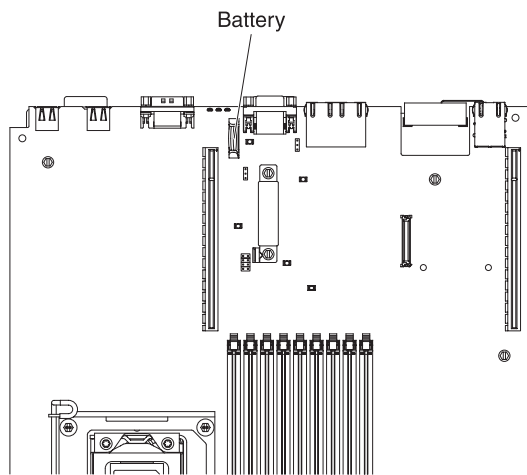

Figure 91. Battery location

- a. If there is a rubber cover on the battery holder, use your fingers to lift the battery cover from the battery connector.
- b. Use one finger to push the battery horizontally away from the PCI riser card in slot 2 and out of its housing.

Attention: Neither tilt nor push the battery by using excessive force.

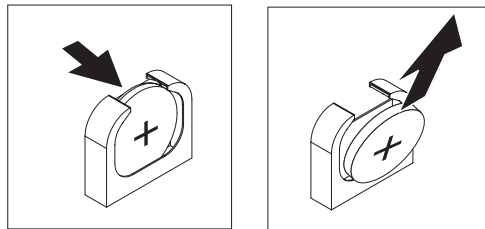

Figure 92. Battery removal

- c. Use your thumb and index finger to lift the battery from the socket.
Attention: Do not lift the battery by using excessive force. Failing to remove the battery properly may damage the socket on the system board. Any damage to the socket may require replacing the system board.
6. Dispose of the battery as required by local ordinances or regulations. See the *IBM Environmental Notices and User's Guide* on the *IBM System x Documentation* CD for more information.

Installing the system battery

Use this information to install the system battery.

About this task

The following notes describe information that you must consider when replacing the system-board battery in the server.

- When replacing the system-board battery, you must replace it with a lithium battery of the same type from the same manufacturer.
- To order replacement batteries, call 1-800-426-7378 within the United States, and 1-800-465-7999 or 1-800-465-6666 within Canada. Outside the U.S. and Canada, call your IBM marketing representative or authorized reseller.
- After you replace the system-board battery, you must reconfigure the server and reset the system date and time.
- To avoid possible danger, read and follow the following safety statement.

Statement 2



CAUTION:

When replacing the lithium battery, use only IBM Part Number 33F8354 or an equivalent type battery recommended by the manufacturer. If your system has a module containing a lithium battery, replace it only with the same module type made by the same manufacturer. The battery contains lithium and can explode if not properly used, handled, or disposed of.

Do not:

- **Throw or immerse into water**
- **Heat to more than 100°C (212°F)**
- **Repair or disassemble**

Dispose of the battery as required by local ordinances or regulations.

To install the replacement system-board battery, complete the following steps:

Procedure

1. Follow any special handling and installation instructions that come with the replacement battery.
2. Insert the new battery:
 - a. Tilt the battery so that you can insert it into the socket on the side opposite the battery clip.



Figure 93. Battery installation

- b. Press the battery down into the socket until it clicks into place. Make sure that the battery clip holds the battery securely.
 - c. If you removed a rubber cover from the battery holder, use your fingers to install the battery cover on top of the battery connector.
3. Install the cover (see “Installing the cover” on page 357).
4. Slide the server into the rack.
5. Reconnect the external cables; then, reconnect the power cords and turn on the peripheral devices and the server.
6. Start the Setup utility and reset the configuration.
 - Set the system date and time.
 - Set the power-on password.
 - Reconfigure the server.

See “Using the Setup utility” on page 460 for details.

Removing and replacing Tier 2 CRUs

You may install a Tier 2 CRU yourself or request IBM to install it, at no additional charge, under the type of warranty service that is designated for your server.

Note: The illustrations in this document might differ slightly from your hardware.

Removing the bezel

Use this information to remove the bezel.

About this task

To remove the bezel, complete the following steps:

Procedure

1. Read the safety information that begins on “Safety” on page vii and “Installation guidelines” on page 347.
2. Turn off the server and peripheral devices and disconnect the power cords.
3. Remove the cover (see “Removing the cover” on page 356).
4. Remove the hard disk drives and filler panels from the hard disk drive bays.
5. Remove the screws from the bezel.

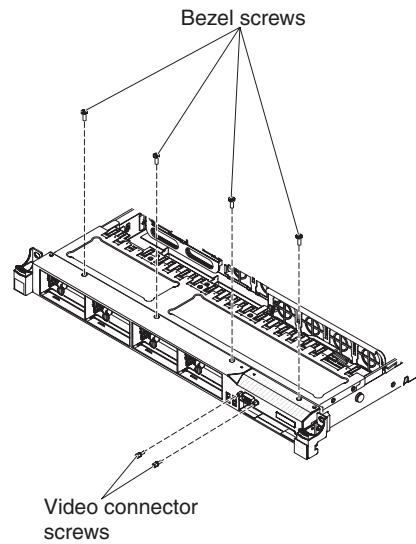

Figure 94. Screws removal

6. Remove the screws from the video connector.
7. Pull the top of the bezel out slightly; then, rotate it downward until the tabs on the bottom of the bezel disengage from the chassis and set it aside.

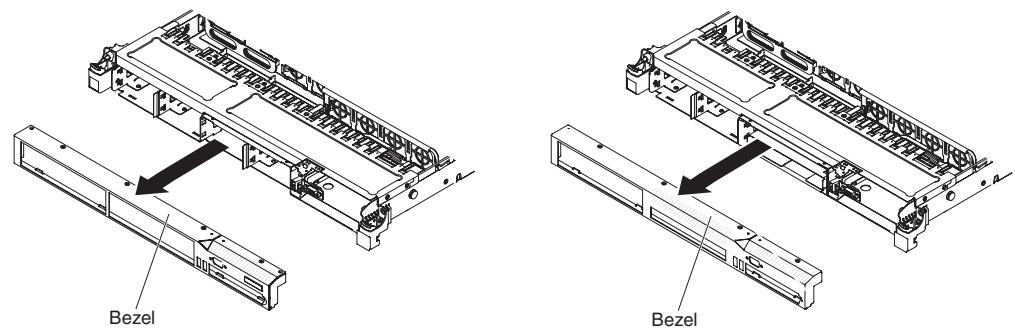

Figure 95. Bezel removal

Installing the bezel

Use this information to install the bezel.

About this task

To install the bezel, complete the following steps:

Procedure

1. Insert the tabs on the bottom of the bezel into the holes on the chassis.
2. Rotate the bezel upward to the server and reinstall the bezel screws.

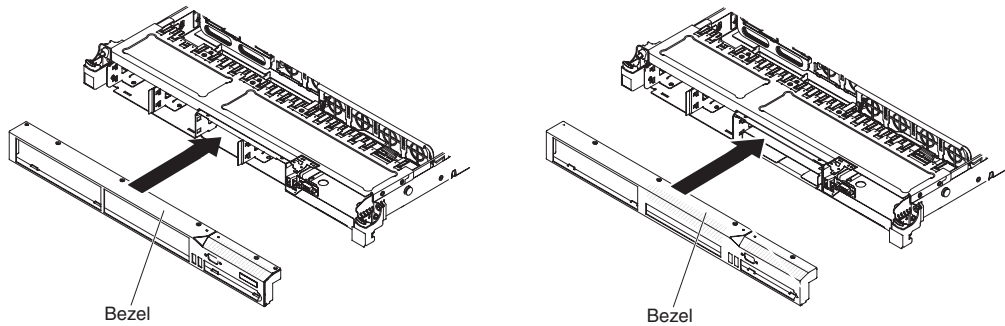

Figure 96. Bezel installation

3. Reinstall the video connector screws.
4. Reinstall the hard disk drives and drive bay filler panels into the drive bays.
5. Install the cover (see "Installing the cover" on page 357).
6. Reconnect the power cords and any cables that you removed.
7. Slide the server into the rack.
8. Turn on the peripheral devices and the server.

Removing an optional optical drive cage

Use this information to remove an optional optical drive cage.

About this task

To remove an optional optical drive cage, complete the following steps:

Procedure

1. Read the safety information that begins on "Safety" on page vii and "Installation guidelines" on page 347.
2. Turn off the server and peripheral devices and disconnect the power cords.
3. Remove the cover (see "Removing the cover" on page 356).
4. Remove the DVD cable (see "Removing the DVD cable" on page 422).
5. Remove the DVD drive (see "Removing an optional DVD drive" on page 375).
6. Remove the bezel (see "Removing the bezel" on page 418).
7. Slide the optional optical drive cage out of the chassis and set it aside.

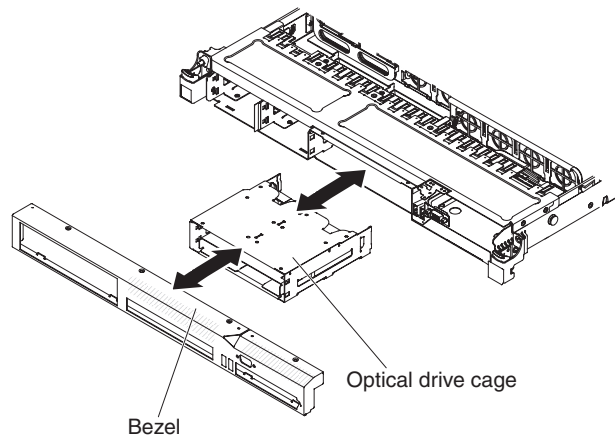

Figure 97. Optical drive cage removal

Installing an optional optical drive cage

Use this information to install an optional optical drive cage.

About this task

To install an optical drive cage, complete the following steps:

Procedure

1. Read the safety information that begins on “Safety” on page vii and “Installation guidelines” on page 347.
2. Turn off the server and peripheral devices and disconnect the power cords.
3. Remove the cover (see “Removing the cover” on page 356).
4. Remove the bezel (see “Removing the bezel” on page 418).
5. Slide the optical drive cage forward into the optical drive bay until the screw holes on the drive cage align with the screw holes on the chassis.

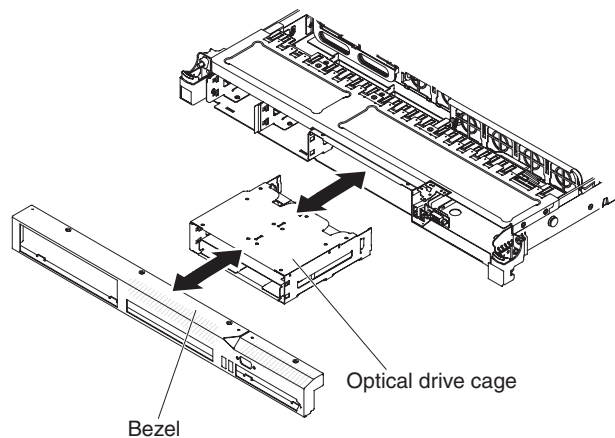

Figure 98. Optical drive cage installation

6. Install the bezel (see “Installing the bezel” on page 419).
7. Install the DVD cable (see “Installing the DVD cable” on page 423).
8. Install the cover (see “Installing the cover” on page 357).
9. Reconnect the power cords and any cables that you removed.

10. Slide the server into the rack.
11. Turn on the peripheral devices and the server.

Removing the DVD cable

Use this information to remove the DVD cable.

About this task

To remove the DVD cable, complete the following steps:

Procedure

1. Read the safety information that begins on “Safety” on page vii and “Installation guidelines” on page 347.
2. Turn off the server and peripheral devices and disconnect the power cords.
3. Remove the cover (see “Removing the cover” on page 356).
4. Remove the fans in fan connectors 2, 3, and 4 (see “Removing a hot-swap fan assembly” on page 396).
5. Remove the DVD drive (see “Removing an optional DVD drive” on page 375).
6. Press and hold the connector release tab; then, remove the DVD cable from the connector on the system board.

Attention: You must press the connector release tab in order to disconnect the DVD cable from the system board. Do not disconnect the DVD cable by using excessive force. Failing to disconnect the DVD cable from the system board properly may damage the connector on the system board. Any damage to the connector may require replacing the system board.

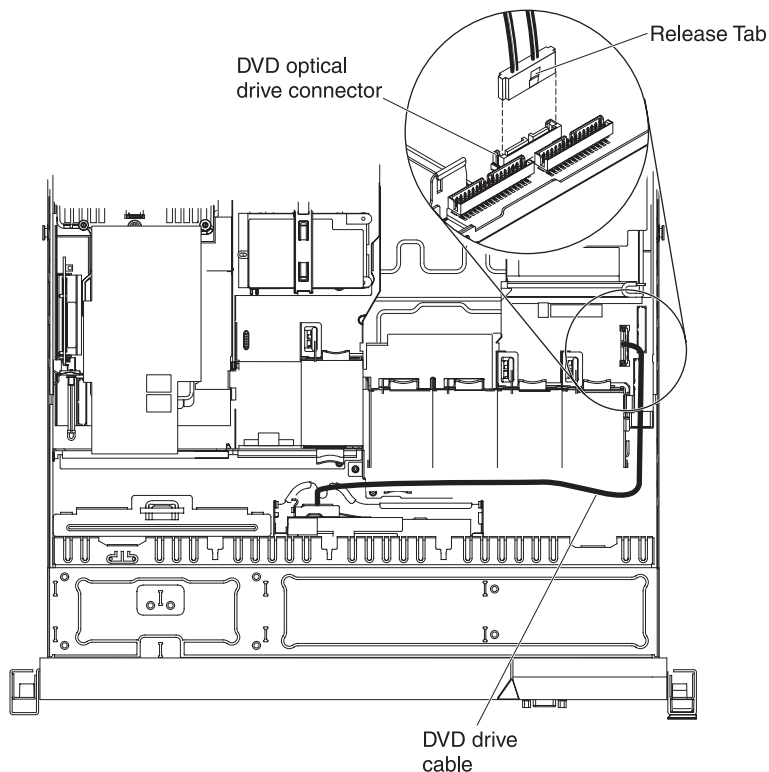

Figure 99. DVD cable connection

7. From the front of the server, grasp the cable connector latch and slide it up toward the fan bracket; then, press the spring latch (right of the cable connector) and slide the cable connector to the right.

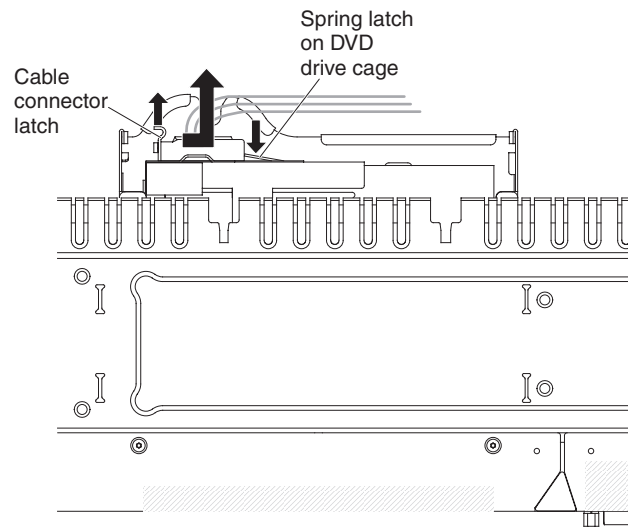

Figure 100. DVD cable removal

8. Remove the cable from the optical drive cage connector and set it aside.

Results

If you are instructed to return the DVD drive cable, follow all packaging instructions, and use any packaging materials for shipping that are supplied to you.

Installing the DVD cable

Use this information to install the DVD cable.

About this task

To install the DVD cable, complete the following cable:

Procedure

1. Read the safety information that begins on “Safety” on page vii and “Installation guidelines” on page 347.
2. Turn off the server and peripheral devices and disconnect the power cords.
3. Remove the cover (see “Removing the cover” on page 356).
4. Align the cable connector with the connector on the rear of the optical drive cage and press the cable connector into the optical drive cage connector until it is firmly seated.
5. Pull the cable connector latch up and hold it there while you slide the cable connector to the left; then, slide the cable connector latch down to lock the cable in place.

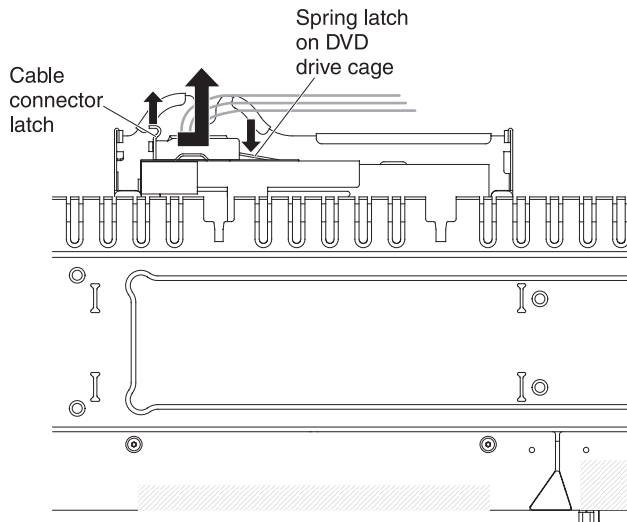

Figure 101. DVD cable installation

The following illustration shows the cable routing for the DVD cable:

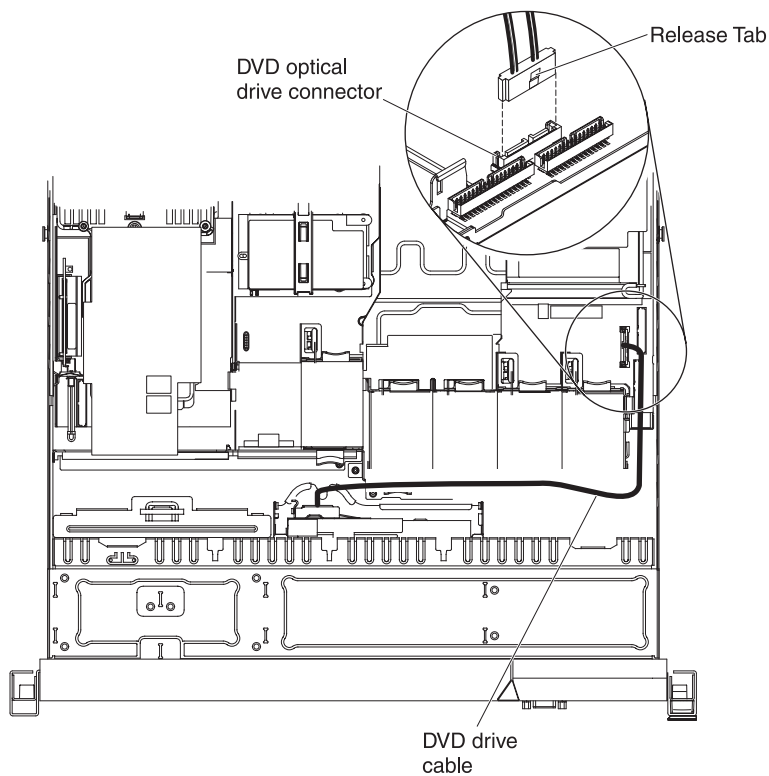

Figure 102. DVD cable connection

6. Reinstall the DVD drive (see "Installing an optional DVD drive" on page 377).
7. Reinstall the fans (see "Installing a hot-swap fan assembly" on page 398).
8. Replace the cover (see "Installing the cover" on page 357).
9. Slide the server into the rack.
10. Reconnect the power cord and any cables that you removed.
11. Turn on the peripheral devices and the server.

Removing a PCI riser-card assembly

Use this information to remove a PCI riser-card assembly.

About this task

Note: A PCI riser-card assembly must be installed in slot 2 even if you do not install an adapter.

To remove a PCI riser-card assembly, complete the following steps:

Procedure

1. Read the safety information that begins on “Safety” on page vii and “Installation guidelines” on page 347.
2. Turn off the server and peripheral devices and disconnect the power cords and all external cables.
3. Remove the cover (see “Removing the cover” on page 356).
4. If an adapter is installed in the PCI riser-card assembly, disconnect any cables that are connected to the adapter.
5. Grasp the rear of the PCI riser-card assembly from the rear and lift it out of the PCI riser-card slot on the system board.

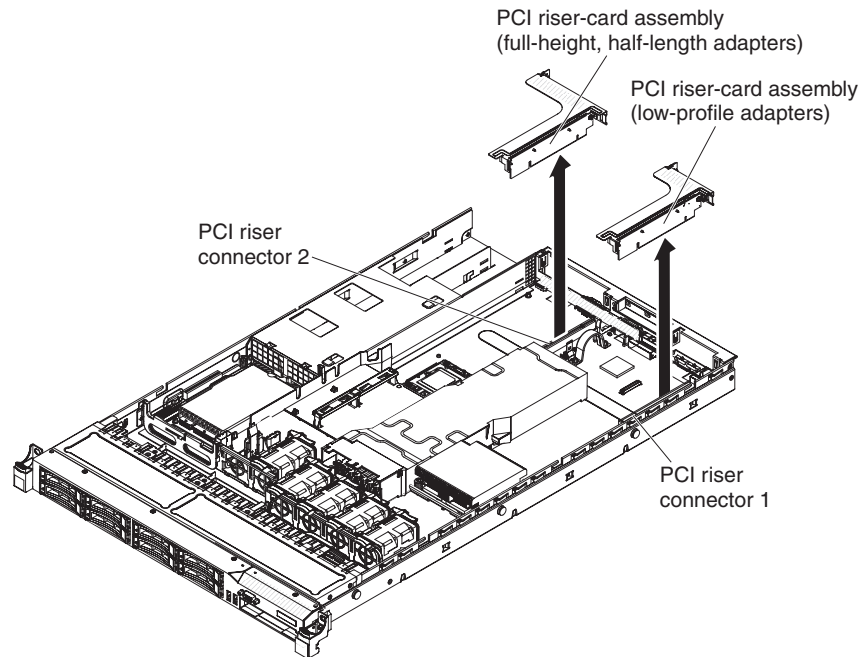

Figure 103. PCI riser-card assembly removal

6. Remove the adapter, if one is present, from the PCI riser-card assembly.
7. Set the adapter and PCI riser-card assembly aside.

Installing a PCI riser-card assembly

Use this information to install a PCI riser-card assembly.

About this task

Note: A PCI riser-card assembly must be installed in slot 2 even if you do not install an adapter.

To install a PCI riser-card assembly, complete the following steps:

Procedure

1. Read the safety information that begins on “Safety” on page vii and “Installation guidelines” on page 347.
2. Turn off the server and peripheral devices and disconnect the power cords and all external cables.
3. Remove the cover (see “Removing the cover” on page 356).
4. Install the adapter in the new PCI riser-card assembly (see “Replacing an adapter” on page 382).
5. Set any jumpers or switches on the adapter as directed by the adapter manufacturer.
6. If you are installing the PCI riser-card assembly on PCI slot connector 1 on the system board, remove the PCI filler panel from the rear of the server.
7. Align the PCI riser-card assembly with the PCI slot connector on the system board; then, press down firmly until the PCI riser-card assembly is seated correctly in the connector on the system board.

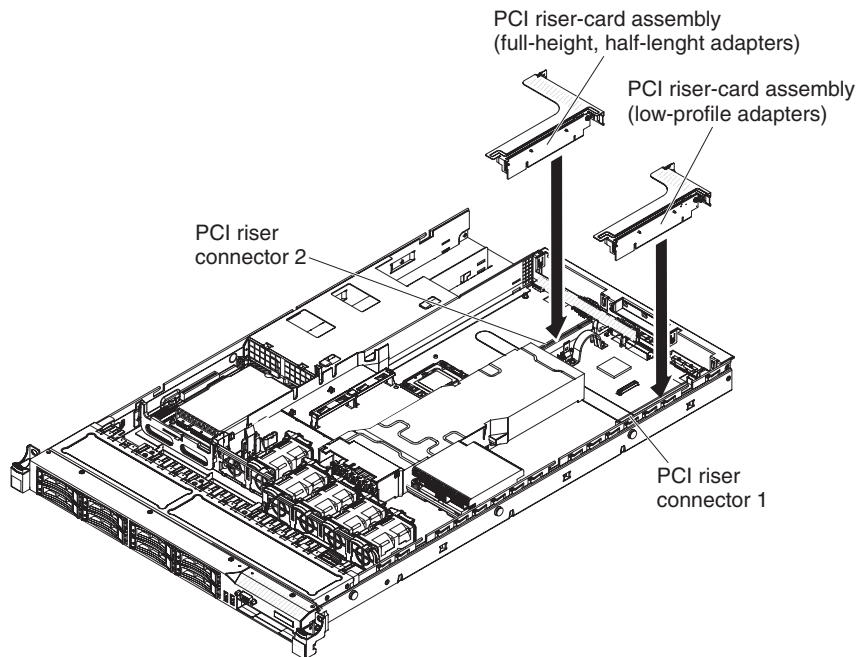

Figure 104. PCI riser-card assembly installation

Removing the PCI riser-card bracket from the riser card

Use this information to remove the PCI riser-card bracket from the riser card.

About this task

To remove the PCI riser-card bracket from the riser card, complete the following steps:

Procedure

1. Read the safety information that begins on “Safety” on page vii and “Installation guidelines” on page 347.
2. Turn off the server and peripheral devices and disconnect the power cords and all external cables.
3. Remove the cover (see “Removing the cover” on page 356).
4. Remove the PCI riser-card assembly (see “Removing a PCI riser-card assembly” on page 425).
5. Remove the screw that attaches the PCI riser card to the PCI bracket.

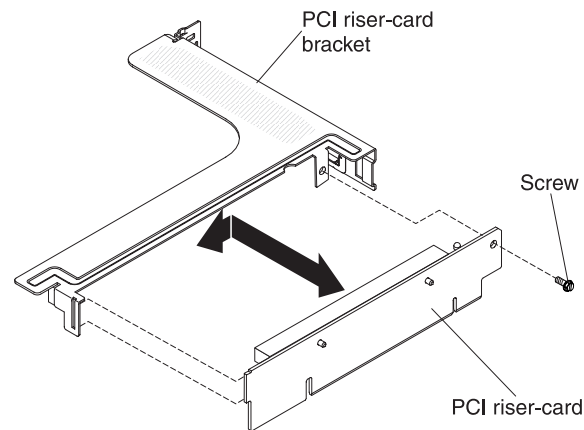

Figure 105. PCI riser-card bracket removal

Results

If you are instructed to return the PCI bracket, follow all packaging instructions, and use any packaging materials for shipping that are supplied to you.

Installing the PCI riser-card bracket to the riser card.

Use this information to install the PCI riser-card bracket from the riser card.

About this task

To install the PCI riser-card bracket to the riser card, complete the following steps:

Procedure

1. Read the safety information that begins on "Safety" on page vii and "Installation guidelines" on page 347.
2. Turn off the server and peripheral devices and disconnect the power cords and all external cables.
3. Remove the cover (see "Removing the cover" on page 356).
4. Align the holes on the PCI riser card and the PCI bracket and install the screw that attaches the PCI riser card to the PCI bracket.

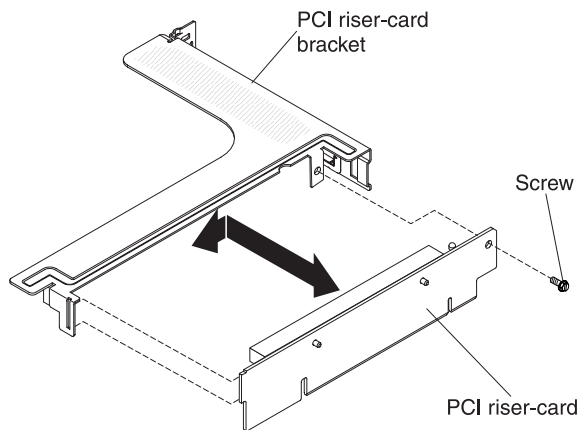

Figure 106. PCI riser-card bracket installation

5. If you need to install an adapter (see "Replacing an adapter" on page 382).
6. Install the PCI riser card assembly (see "Installing a PCI riser-card assembly" on page 426).
7. Reconnect the cables for the adapter.
8. Install the cover (see "Installing the cover" on page 357).
9. Slide the server into the rack.
10. Reconnect the power cords and any cables that you removed.
11. Turn on the peripheral devices and the server.

Removing the hot-swap SAS/SATA hard disk drive backplane

Use this information to remove the hot-swap SAS/SATA hard disk drive backplane.

About this task

To remove the hot-swap SAS/SATA hard disk drive backplane, complete the following steps:

Procedure

1. Read the safety information that begins on “Safety” on page vii and “Installation guidelines” on page 347.
2. Turn off the server and peripheral devices and disconnect the power cords and all external cables.
3. Remove the cover (see “Removing the cover” on page 356).
4. Pull the hard disk drives and filler panels out of the server slightly to disengage them from the hard disk drive backplane.
5. Disconnect all cables from the hard disk drive backplane.

Note: You can also choose to disconnect the cables after removing the backplane from the brackets, if that is easier for you.

6. Lift the hard disk drive backplane up to remove it from the server.

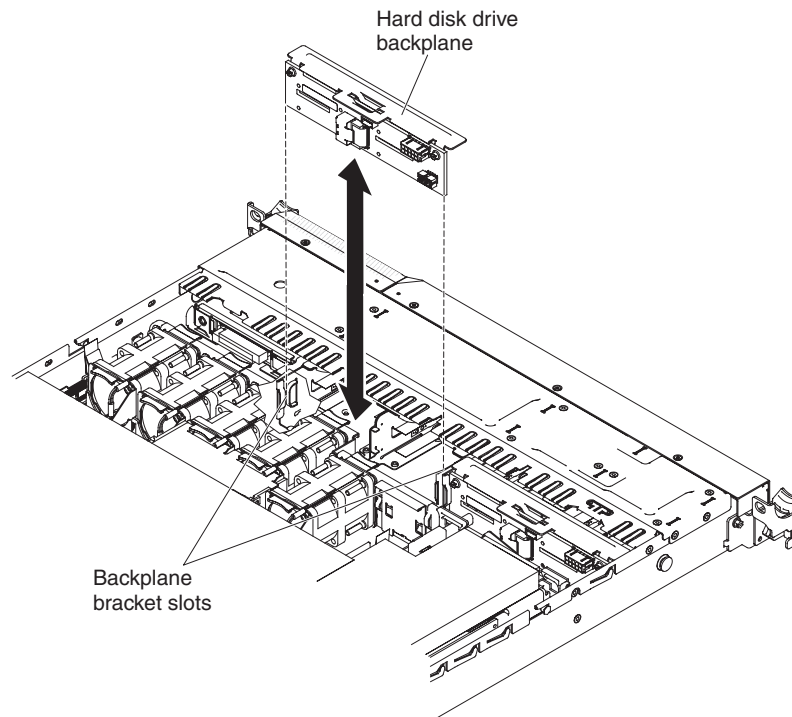

Figure 107. Backplane removal

Results

If you are instructed to return the hard disk drive backplane, follow all packaging instructions, and use any packaging materials for shipping that are supplied to you.

Installing the hot-swap SAS/SATA hard disk drive backplane

Use this information to install the hot-swap SAS/SATA hard disk drive backplane.

About this task

To install the replacement hot-swap SAS/SATA hard disk drive backplane, complete the following steps:

Procedure

1. Read the safety information that begins on “Safety” on page vii and “Installation guidelines” on page 347.
2. Turn off the server and peripheral devices and disconnect the power cords and all external cables.
3. Remove the cover (see “Removing the cover” on page 356).
4. Align the sides of the hard disk drive backplane with the slots on the backplane bracket.
5. Insert the hard disk drive backplane into the slots on the backplane bracket and push the hard disk drive backplane down until the backplane is fully seated.

Note: You can reconnect the cables to the hard disk drive backplane before installing the backplane onto the brackets or you can connect the cables after you install the backplane, if that is easier for you.

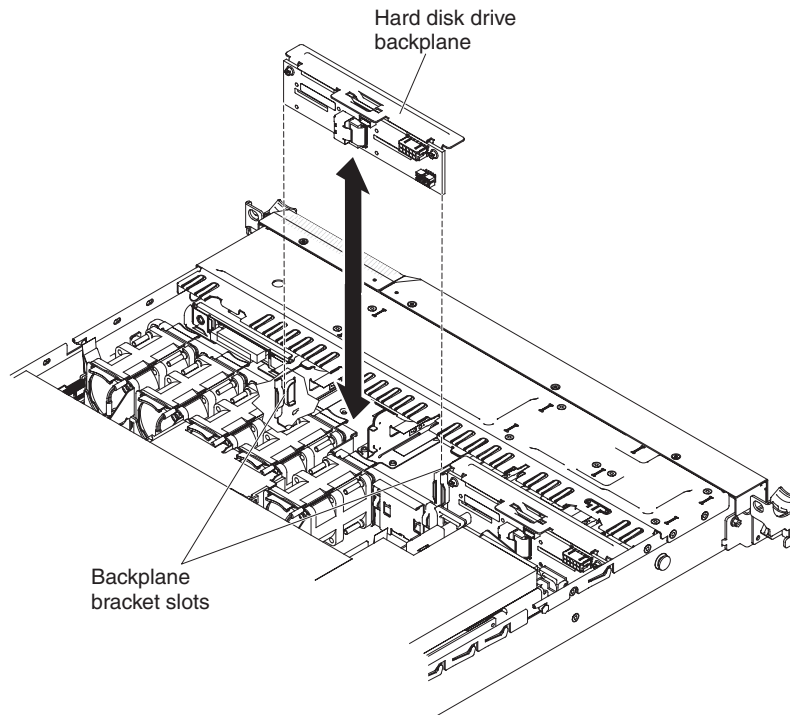

Figure 108. Backplane installation

6. Reconnect the cables to the hard disk drive backplane.
7. Reinstall the hard disk drives and filler panels.
8. Install the cover (see “Installing the cover” on page 357).
9. Slide the server into the rack.

10. Reconnect the power cords and any cables that you removed.
11. Turn on the peripheral devices and the server.

Removing the simple-swap SATA hard disk drive backplate assembly

Use this information to remove the simple-swap SATA hard disk drive backplate assembly.

About this task

To remove the simple-swap SATA hard disk drive backplate assembly, complete the following steps:

Procedure

1. Read the safety information that begins on “Safety” on page vii and “Installation guidelines” on page 347.
2. Turn off the server and peripheral devices and disconnect the power cords and all external cables.
3. Remove the cover (see “Removing the cover” on page 356).
4. Slide the blue release tab to the right with one finger while using another finger to grasp the black drive handle and pull the hard disk drives out of the server slightly (also the filler panels) to disengage them from the hard disk drive backplate.
5. Disconnect the power and signal cables from the system board.

Note: You can also choose to disconnect the cables after you remove the backplate from the brackets, if that is easier for you.

6. Lift the hard disk drive backplate up to disengage the backplate assembly from the backplane bracket and remove it from the server.

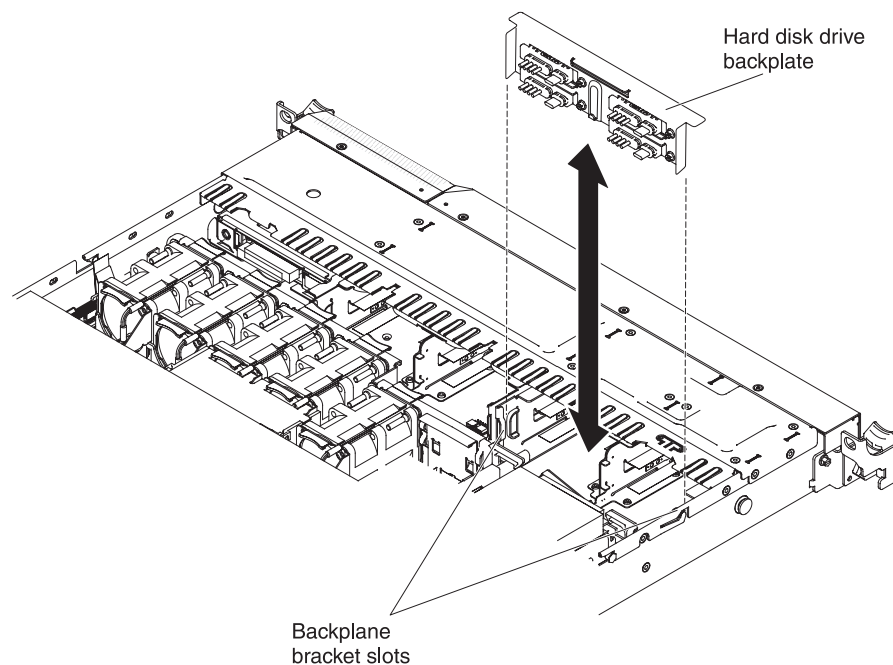

Figure 109. Backplate assembly removal

Results

If you are instructed to return the hard disk drive backplate assembly, follow all packaging instructions, and use any packaging materials for shipping that are supplied to you.

Installing the simple-swap SATA hard disk drive backplate assembly

Use this information to install the simple-swap SATA hard disk drive backplate assembly.

About this task

To install the replacement simple-swap SATA hard disk drive backplate assembly, complete the following steps:

Procedure

1. Read the safety information that begins on "Safety" on page vii and "Installation guidelines" on page 347.
2. Turn off the server and peripheral devices and disconnect the power cords and all external cables.
3. Remove the cover (see "Removing the cover" on page 356).
4. Align the sides of the hard disk drive backplate with the slots on the backplane bracket.

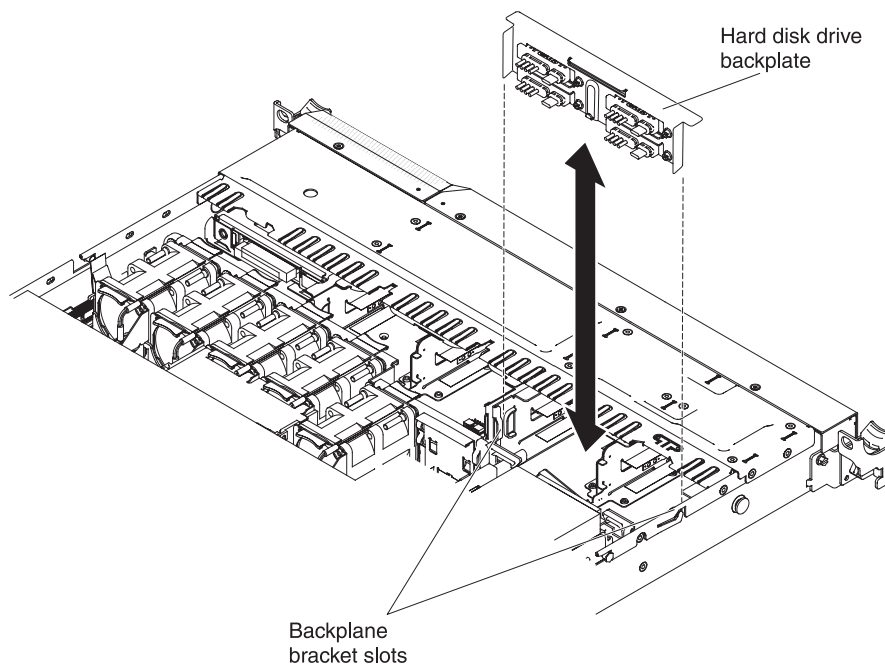

Figure 110. Backplate assembly installation

5. Insert the hard disk drive backplate into the slots on the backplane bracket and push the hard disk drive backplate assembly down until the backplate is seated firmly.
6. Connect the power and signal cables to the system board. Route the power cable from the drive backplate through the hole on the right of the blue

adapter retention bracket and connect it to the **Simple-swap SATA power connector** (see “System-board internal connectors” on page 18); then, route the signal cable from the drive backplate over the blue adapter retention bracket and connect it to the **Simple-swap SATA signal connector**, as shown in the following illustration.

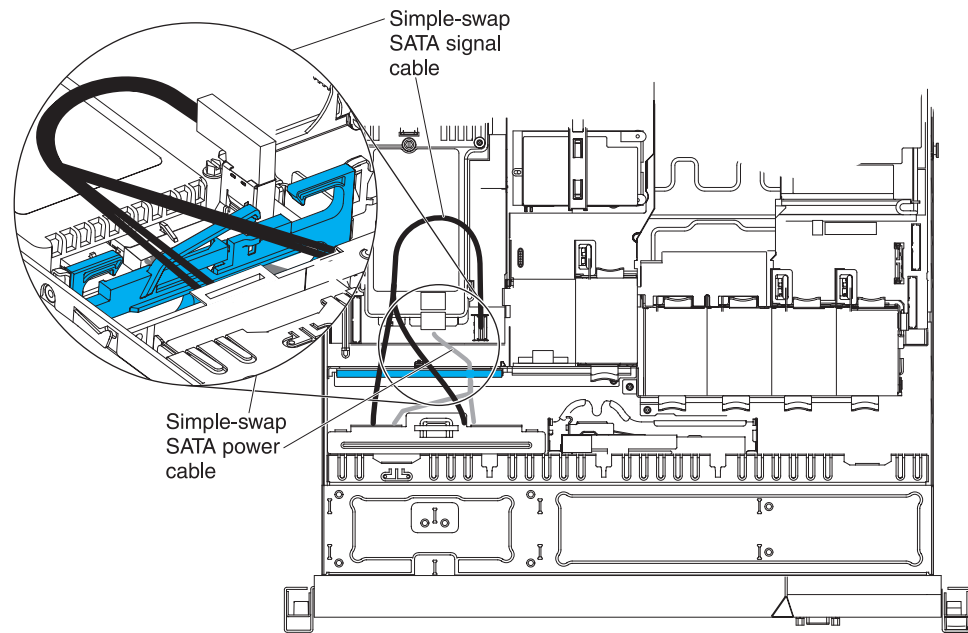

Figure 111. Backplate assembly cable connection

7. Reinstall the hard disk drives and filler panels.
8. Install the cover (see “Installing the cover” on page 357).
9. Slide the server into the rack.
10. Reconnect the power cords and any cables that you removed.
11. Turn on the peripheral devices and the server.

Removing the operator information panel assembly

Use this information to remove the operator information panel assembly.

About this task

To remove the operator information panel, complete the following steps.

Procedure

1. Read the safety information that begins on “Safety” on page vii and “Installation guidelines” on page 347.
2. Turn off the server and peripheral devices and disconnect the power cords and all external cables.
3. Remove the cover (see “Removing the cover” on page 356).
4. Disconnect the cable from the back of the operator information panel assembly.

5. Use an object to push down on the release tab; hold down the release tab and push the blue push point on the rear of the panel to the front of the server.

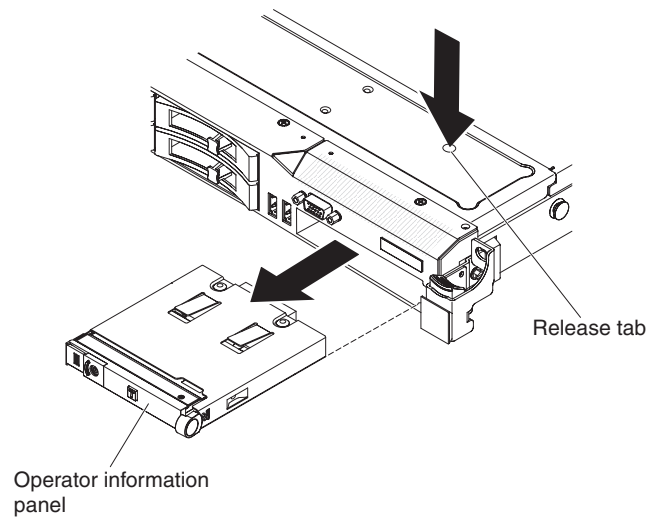

Figure 112. Operator information panel assembly removal

6. From the front of the server, carefully pull the assembly out of the server while you move it slightly from side to side.

Results

If you are instructed to return the operator information panel assembly, follow all packaging instructions, and use any packaging materials for shipping that are supplied to you.

Installing the operator information panel assembly

Use this information to install the operator information panel assembly.

About this task

To install the operator information panel, complete the following steps.

Procedure

1. Read the safety information that begins on “Safety” on page vii and “Installation guidelines” on page 347.
2. From the front of the server, slide the operator information panel into the server until it clicks into place.
3. Inside the server, connect the cable to the rear of the operator information panel assembly.

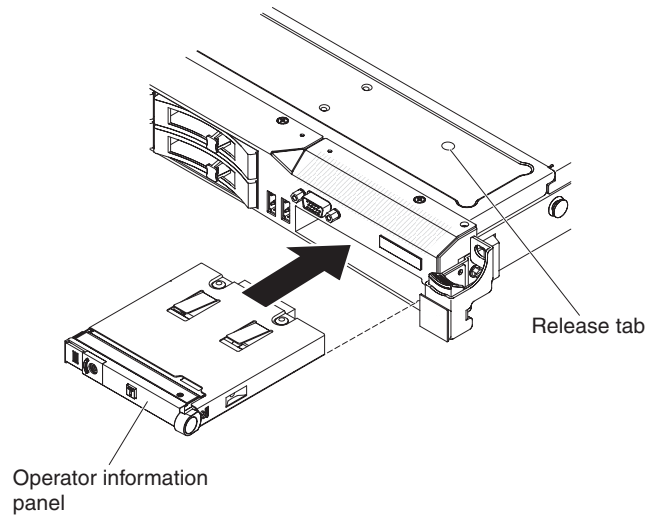

Figure 113. Operator information panel assembly installation

The following illustration shows the cable routing for the operator information panel. The following notes describe additional information when you install the cable:

- You may remove the optional optical drive cable to obtain more room before you install or remove the operator information panel cable.
- To connect the operator information panel cable on the system board, press evenly on the cable. Pressing on one side of the cable might cause damage to the cable or connector.
- The operation information panel cable should go in between the Video/USB cable (on the bottom) and the CD/DVD cable (on the top) when all three cables are installed in the server.

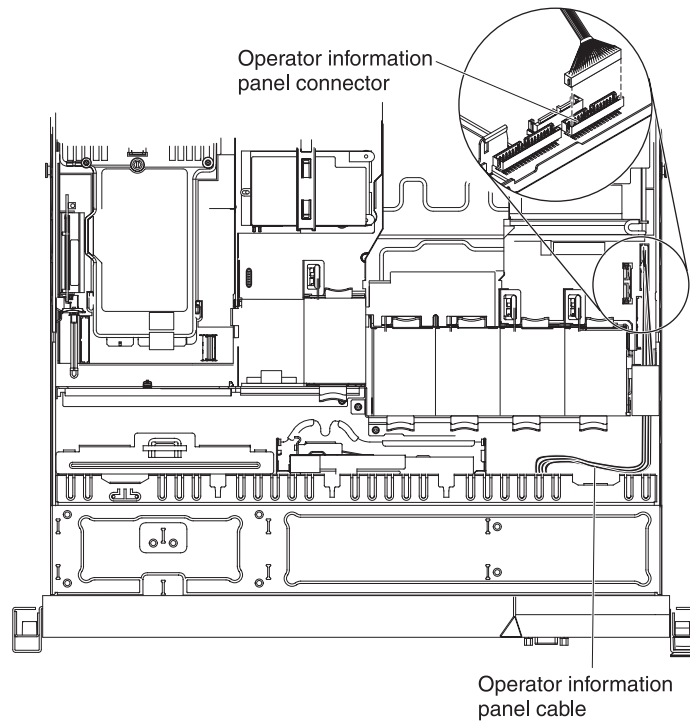

Figure 114. Operator information panel assembly cable connection

4. Install the cover (see "Installing the cover" on page 357).
5. Slide the server into the rack.
6. Reconnect the power cords and any cables that you removed.
7. Turn on the peripheral devices and the server.

Removing and replacing FRUs

FRUs must be replaced or installed only by trained service technicians.

Note: The illustrations in this document might differ slightly from the hardware.

Removing the 240 VA safety cover

Use this information to remove the 240 VA safety cover.

About this task

To remove the 240 VA safety cover, complete the following steps:

Procedure

1. Read the safety information that begins on “Safety” on page vii and “Installation guidelines” on page 347.
2. Turn off the server and peripheral devices and disconnect the power cords and all external cables.
3. Remove the cover (see “Removing the cover” on page 356).
4. Remove the SAS/SATA riser-card assembly (see “Removing the SAS/SATA RAID riser-card assembly” on page 385).
5. Remove the screw from the safety cover.

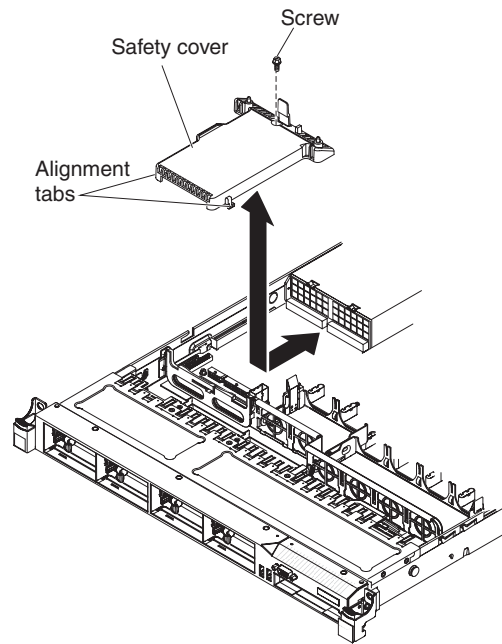

Figure 115. Safety cover removal

6. Disconnect the hard disk drive backplane cables from the connector on the front of the safety cover.
7. Slide the safety cover forward to disengage it from the system board, then lift it out of the server.
- 8.
- 9.

Results

If you are instructed to return the safety cover, follow all packaging instructions, and use any packaging materials for shipping that are supplied to you.

Installing the 240 VA safety cover

Use this information to install the 240 VA safety cover.

About this task

To install the 240 VA safety cover, complete the following steps:

Procedure

1. Read the safety information that begins on “Safety” on page vii and “Installation guidelines” on page 347.
2. Turn off the server and peripheral devices and disconnect the power cords and all external cables.
3. Remove the cover (see “Removing the cover” on page 356).
4. Remove the SAS/SATA riser-card assembly (see “Removing the SAS/SATA RAID riser-card assembly” on page 385).
5. Align the tabs on the bottom of the safety cover with the slots on the system board and lower the safety cover into the system board.

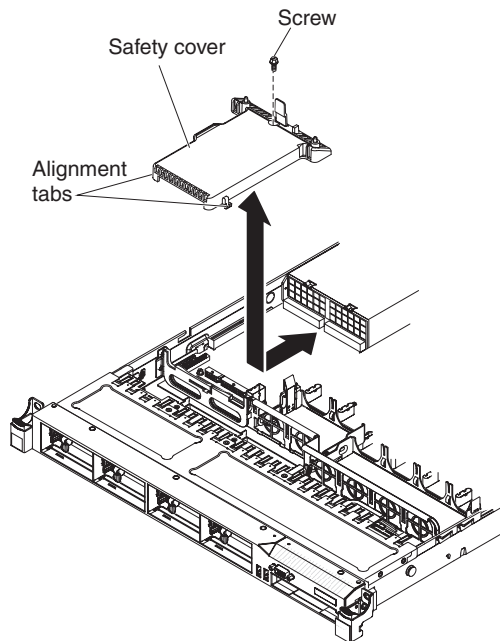

Figure 116. Safety cover installation

6. Slide the safety cover toward the back of the server until it is secure.
7. Connect the hard disk drive backplane cables into the connector in front of the safety cover.
8. Install the screw to secure the safety cover.
9. Install the SAS/SATA riser-card assembly (see “Installing the SAS/SATA RAID riser-card assembly” on page 386).
10. Install the cover (see “Installing the cover” on page 357).
11. Slide the server into the rack.
12. Reconnect the power cords and any cables that you removed.
13. Turn on the peripheral devices and the server.

Removing a microprocessor and heat sink

Use this information to remove a microprocessor and heat sink.

About this task

Attention:

- Microprocessors are to be removed only by trained service technicians.

Important: Always use the microprocessor installation tool to remove a microprocessor. Failing to use the microprocessor installation tool may damage the microprocessor sockets on the system board. Any damage to the microprocessor sockets may require replacing the system board.

- Do not allow the thermal grease on the microprocessor and heat sink to come in contact with anything. Contact with any surface can compromise the thermal grease and the microprocessor socket.
- Dropping the microprocessor during installation or removal can damage the contacts.
- Do not touch the microprocessor contacts; handle the microprocessor by the edges only. Contaminants on the microprocessor contacts, such as oil from your skin, can cause connection failures between the contacts and the socket.

To remove a microprocessor and heat sink, complete the following steps:

Procedure

1. Read the safety information that begins on “Safety” on page vii and “Installation guidelines” on page 347.
2. Turn off the server and peripheral devices and disconnect the power cords and all external cables.
3. Remove the cover (see “Removing the cover” on page 356).
4. Disconnect any cables that impede access to the heat sink and microprocessor.
5. Open the heat sink release lever to the fully open position.
6. Lift the heat sink out of the server. After removal, place the heat sink on its side on a clean, flat surface.

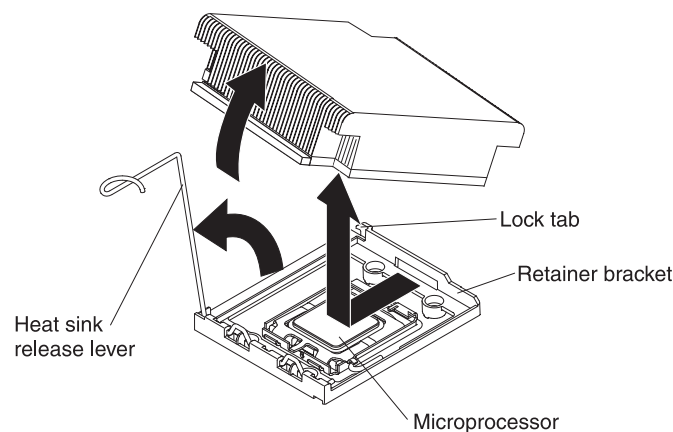

Figure 117. Heat sink removal

7. Release the microprocessor retention latch by pressing down on the end, moving it to the side, and releasing it to the open position.

- Open the microprocessor bracket frame by lifting up the tab on the top edge. Keep the bracket frame in the open position.

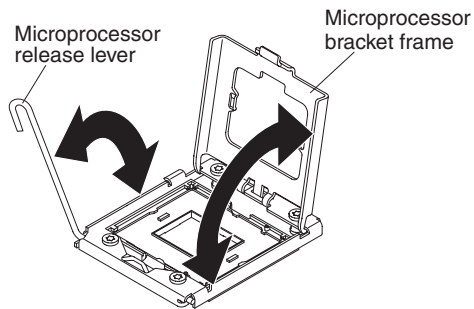

Figure 118. Microprocessor bracket frame disengagement

- Locate the microprocessor installation tool that comes with the new microprocessor.
- Twist the handle on the microprocessor tool counterclockwise so that it is in the open position.

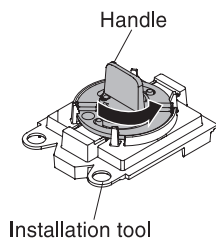

Figure 119. Installation tool handle adjustment

- Align the installation tool with the alignment pins on the microprocessor socket and lower the tool down over the microprocessor.

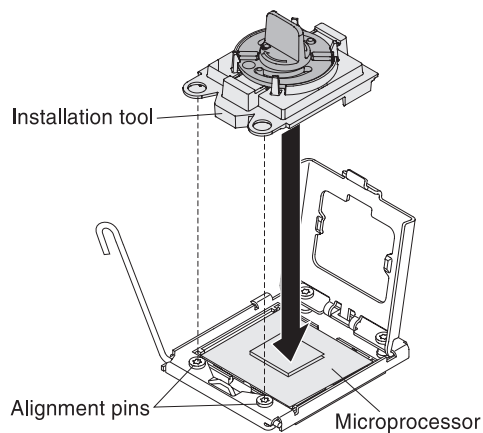

Figure 120. Installation tool alignment

- Twist the handle on the installation tool clockwise and lift the microprocessor out of the socket.

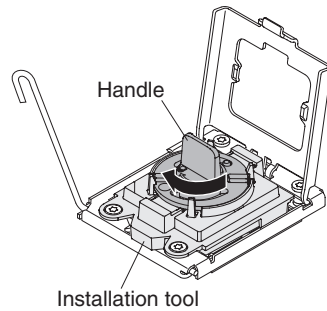

Figure 121. Installation tool handle adjustment

13. Carefully lift the microprocessor straight up and out of the socket, and place it on a static-protective surface. Remove the microprocessor from the installation tool by twisting the handle counterclockwise.
14. If you do not intend to install a microprocessor in the socket, install the socket dust cover that you removed in step 4b on page 442 on the socket.

Attention: The pins on the socket are fragile. Any damage to the pins may require replacing the system board.

Results

If you are instructed to return the microprocessor, follow all packaging instructions, and use any packaging materials for shipping that are supplied to you.

Installing a microprocessor and heat sink

Use this information to install a microprocessor and heat sink.

About this task

The following notes describe the type of microprocessor that the server supports and other information that you must consider when you install a microprocessor and heat sink:

- Microprocessors are to be installed only by trained service technicians.

Important: Always use the microprocessor installation tool to remove a microprocessor. Failing to use the microprocessor installation tool may damage the microprocessor sockets on the system board. Any damage to the microprocessor sockets may require replacing the system board.

- The server supports up to two Intel Xeon multi-core microprocessors. See <http://www.ibm.com/systems/info/x86servers/serverproven/compat/us/> for a list of supported microprocessors.
- Do not install an Intel Xeon™ 5500 series microprocessor and an Intel Xeon™ 5600 series microprocessor in the same server.
- Do not mix dual-core, quad-core, and six-core microprocessors in the same server.
- The first microprocessor must always be installed in microprocessor socket 1 on the system board.
- When one microprocessor is installed, a heat sink filler is not required for microprocessor socket 2, however, the microprocessor 2 air baffle and the DIMM air baffle must be installed to provide proper system cooling.

- Do not remove the first microprocessor from the system board when you install the second microprocessor.
- When you install the second microprocessor, you must also install additional memory and the sixth fan. See “Installing a memory module” on page 363 for details about the installation sequence.
- To ensure proper server operation when you install an additional microprocessor, use microprocessors that have the same QuickPath Interconnect (QPI) link speed, integrated memory controller frequency, core frequency, power segment, internal cache size, and type.
- Mixing microprocessors of different stepping levels within the same server model is supported.
- When mixing microprocessors with different stepping levels within the same server model, you do not have to install the microprocessor with lowest stepping level and features in microprocessor socket 1.
- Both microprocessor voltage regulator modules are integrated on the system board.
- If you have to replace a microprocessor, call for service.
- Read the documentation that comes with the microprocessor, so that you can determine whether you have to update the server firmware. To download the latest level of server firmware and other code updates for your server, go to <http://www.ibm.com/supportportal/>.
- The microprocessor speeds are automatically set for this server; therefore, you do not have to set any microprocessor frequency-selection jumpers or switches.
- If the thermal-grease protective cover (for example, a plastic cap or tape liner) is removed from the heat sink, do not touch the thermal grease on the bottom of the heat sink or set down the heat sink. For more information about applying or working with thermal grease, see “Thermal grease” on page 446.

Note: Removing the heat sink from the microprocessor destroys the even distribution of the thermal grease and requires replacing the thermal grease.

- To order an additional optional microprocessor, contact your IBM marketing representative or authorized reseller.

To install an additional microprocessor and heat sink, complete the following steps:

Attention: When you handle static-sensitive devices, take precautions to avoid damage from static electricity. For details about handling these devices, see “Handling static-sensitive devices” on page 350.

Procedure

1. Read the safety information that begins on “Safety” on page vii and “Installation guidelines” on page 347.
2. Turn off the server and peripheral devices and disconnect the power cords and all external cables.
3. Remove the cover (see “Removing the cover” on page 356).
4. Install the microprocessor:
 - a. Press down and out on the release lever on microprocessor socket and lift up the microprocessor release lever until it stops in the fully open position.
 - b. Lift the hinged microprocessor bracket frame into an open position and remove the microprocessor socket dust cover, tape, or label from the surface of the microprocessor socket, if one is present. Store the socket dust cover in a safe place.

Attention: When you handle static-sensitive devices, take precautions to avoid damage from static electricity. For details about handling these devices, see “Handling static-sensitive devices” on page 350.

- c. Touch the static-protective package that contains the new microprocessor to any *unpainted* metal surface on the server; then, remove the microprocessor from the package.

Attention:

- Do not touch the microprocessor contacts; handle the microprocessor by the edges only. Contaminants on the microprocessor contacts, such as oil from your skin, can cause connection failures between the contacts and the socket.
 - Handle the microprocessor carefully. Dropping the microprocessor during installation or removal can damage the contacts.
 - Do not use excessive force when you press the microprocessor into the socket.
 - Make sure that the microprocessor is oriented and aligned and positioned in the socket before you try to close the lever.
- d. If there is a plastic protective cover on the bottom of the microprocessor, carefully remove it.

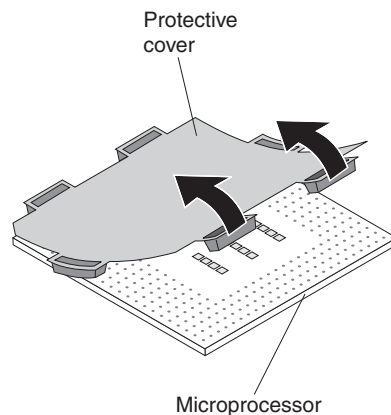

Figure 122. Protective cover removal

- e. Locate the microprocessor installation tool that comes with the new microprocessor.
- f. Twist the handle of the installation tool counterclockwise so that it is in the open position.

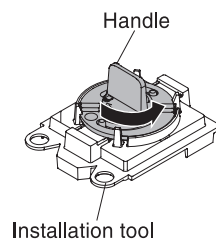

Figure 123. Installation tool handle adjustment

- g. Align the microprocessor alignment slots with the alignment pins on the microprocessor installation tool and place the microprocessor on the

underside of the tool so that the tool can grasp the microprocessor correctly.

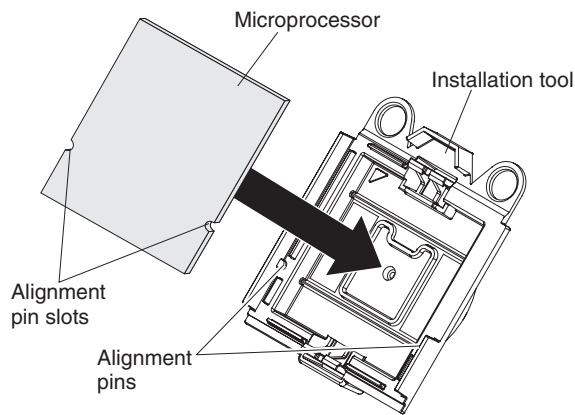

Figure 124. Microprocessor alignment

- h. Twist the handle of the installation tool clockwise to secure the microprocessor in the tool.

Note: You can pick up or release the microprocessor by twisting the microprocessor installation tool handle.

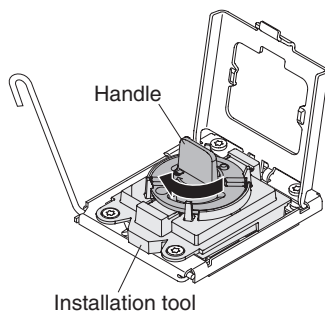

Figure 125. Installation tool handle adjustment

- i. Carefully align the microprocessor installation tool over the microprocessor socket.

Attention: The microprocessor fits only one way on the socket. You must place a microprocessor straight down on the socket to avoid damaging the pins on the socket. The pins on the socket are fragile. Any damage to the pins may require replacing the system board.

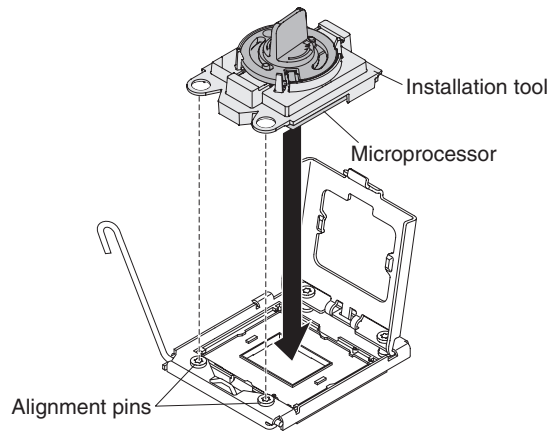

Figure 126. Microprocessor installation

- j. Twist the handle on the microprocessor tool counterclockwise to insert the microprocessor into the socket.

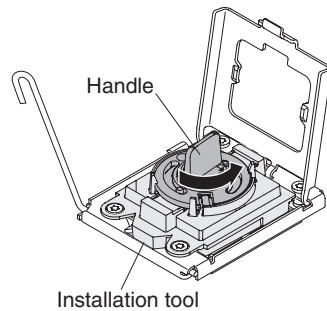

Figure 127. Installation tool handle adjustment

- k. Close the microprocessor bracket frame.
 - l. Carefully close the microprocessor release lever to the closed position to secure the microprocessor in the socket.
5. Install the heat sink:
- a. Clean the grease from the heat sink and apply new grease on the microprocessor.
 - b. Align the heat sink on top of the microprocessor.
 - c. Lower the rear flange of the heat sink into the opening in the retainer bracket and press down firmly on the front of the heat sink until it is seated securely.

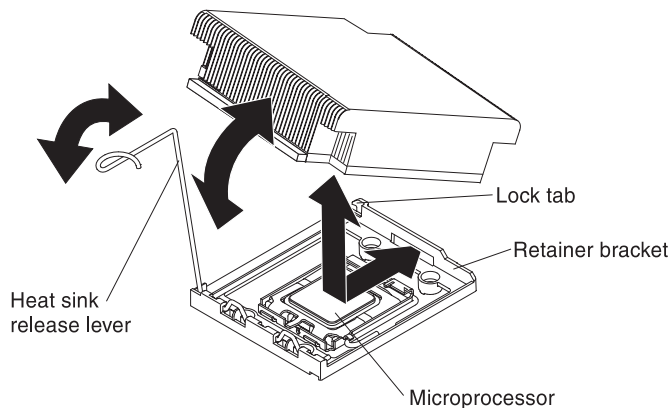

Figure 128. Heat sink installation

- d. Rotate the heat-sink release lever to the closed position and hook it underneath the lock tab.
6. If you installed the second microprocessor, install the sixth fan (see “Installing a hot-swap fan assembly” on page 398).
7. If you removed the microprocessor 2 air baffle, install it (see “Installing the microprocessor 2 air baffle” on page 359).

Thermal grease

The thermal grease must be replaced whenever the heat sink has been removed from the top of the microprocessor and is going to be reused or when debris is found in the grease.

About this task

When you are installing the heat sink on the same microprocessor that is was removed from, make sure that the following requirements are met:

- The thermal grease on the heat sink and microprocessor is not contaminated.
- Additional thermal grease is not added to the existing thermal grease on the heat sink and microprocessor.

Notes:

- Read the safety information that begins on “Safety” on page vii.
- Read the “Installation guidelines” on page 347.
- Read “Handling static-sensitive devices” on page 350.

To replace damaged or contaminated thermal grease on the microprocessor and heat sink, complete the following steps:

Procedure

1. Place the heat sink on a clean work surface.
2. Remove the cleaning pad from its package and unfold it completely.
3. Use the cleaning pad to wipe the thermal grease from the bottom of the heat sink.

Note: Make sure that all of the thermal grease is removed.

4. Use a clean area of the cleaning pad to wipe the thermal grease from the microprocessor; then, dispose of the cleaning pad after all of the thermal grease is removed.

5. Use the thermal-grease syringe to place 9 uniformly spaced dots of 0.02 mL each on the top of the microprocessor. The outermost dots must be within approximately 5 mm of the edge of the microprocessor; this is to ensure uniform distribution of the grease.

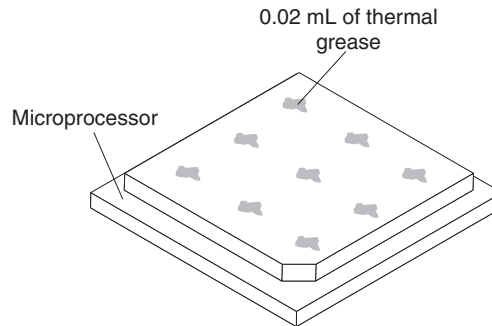

Figure 129. Thermal grease distribution

Note: If the grease is properly applied, approximately half of the grease will remain in the syringe.

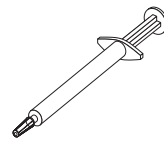

Figure 130. Syringe

6. Install the heat sink onto the microprocessor.

Removing a heat sink retention module

Use this information to remove a heat sink retention module.

About this task

To remove a heat sink retention module, complete the following steps:

Procedure

1. Read the safety information that begins on “Safety” on page vii and “Installation guidelines” on page 347.
2. Turn off the server and peripheral devices and disconnect the power cords and all external cables.
3. Remove the cover (see “Removing the cover” on page 356).
4. Remove the applicable air baffles (see “Removing the DIMM air baffle” on page 360 and “Removing the microprocessor 2 air baffle” on page 358).
5. Remove the microprocessor and heat sink (see “Removing a microprocessor and heat sink” on page 439).

Attention: When you remove a microprocessor and heat sink, be sure to keep each heat sink with its microprocessor for reinstallation.

6. Use a screwdriver and remove the four screws that secure the retention module to the system board; then, lift the retention module from the system board.

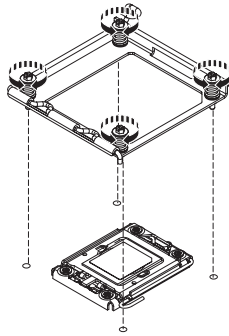

Figure 131. Heat sink retention module removal

Results

If you are instructed to return the heat sink retention module, follow all the packaging instructions, and use any packaging materials for shipping that are supplied to you.

Installing a heat sink retention module

Use this information to install a heat sink retention module.

About this task

To install a heat sink retention module, complete the following steps:

Procedure

1. Read the safety information that begins on “Safety” on page vii and “Installation guidelines” on page 347.
2. Turn off the server and peripheral devices and disconnect the power cords and all external cables.
3. Remove the cover (see “Removing the cover” on page 356).
4. Remove the applicable air baffles (see “Removing the DIMM air baffle” on page 360 and “Removing the microprocessor 2 air baffle” on page 358).
5. Align the retention module with the holes on the system board.
6. Use a screwdriver to reinstall the four screws that you removed earlier.

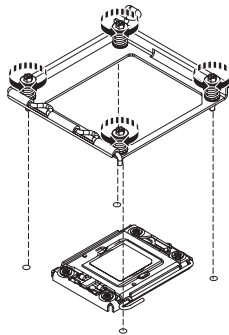

Figure 132. Heat sink retention module installation

7. Reinstall the microprocessor and heat sink (see “Installing a microprocessor and heat sink” on page 441).
8. Reinstall the air baffle.

9. Install the cover (see “Installing the cover” on page 357).
10. Slide the server into the rack.
11. Reconnect the power cords and any cables that you removed.
12. Turn on the peripheral devices and the server.

Removing the system board

Use this information to remove the system board.

About this task

To remove the system board, complete the following steps.

Notes:

1. When you replace the system board, make sure that you remove the virtual media key and place it on the new system board. For information about the location of the key, see “Removing the virtual media key” on page 406.
2. When you replace the system board, you must either update the server with the latest firmware or restore the pre-existing firmware that the customer provides on a diskette or CD image. Make sure that you have the latest firmware or a copy of the pre-existing firmware before you proceed.

Procedure

1. Read the safety information that begins on “Safety” on page vii and “Installation guidelines” on page 347.
2. Turn off the server and peripheral devices and disconnect the power cords and all external cables.
3. Remove the cover (see “Removing the cover” on page 356).

Note: When you replace the system board, you must either update the server with the latest firmware or restore the pre-existing firmware that the customer provides on a diskette or CD image. Make sure that you have the latest firmware or a copy of the pre-existing firmware before you proceed.

4. Pull the power supplies out of the rear of the server, just enough to disengage them from the server.
5. Remove all PCI riser-card assemblies and adapters (see “Removing a PCI riser-card assembly” on page 425).
6. Remove the SAS/SATA RAID riser-card assembly (see “Removing the SAS/SATA RAID riser-card assembly” on page 385).
7. Remove the microprocessor 2 and DIMM air baffles from the system board (see “Removing the microprocessor 2 air baffle” on page 358 and “Removing the DIMM air baffle” on page 360).
8. (Trained service technician only) Remove all heat sinks and microprocessors, and set them aside on a static-protective surface for reinstallation (see “Removing a microprocessor and heat sink” on page 439).
 - a. Remove the socket covers from the microprocessor sockets on the new system board and place them on the microprocessor sockets of the system board you are removing.
 - b. Do not allow the thermal grease to come in contact with anything, and keep each heat sink paired with its microprocessor for reinstallation. Contact with any surface can compromise the thermal grease and the microprocessor socket. A mismatch between the microprocessor and its original heat sink can require the installation of a new heat sink.

9. Remove the memory modules and set them aside on a static-protective surface for reinstallation (see “Removing a memory module” on page 362).

Note: Make a note of the location of each DIMM as you remove it, so that you can later reinstall it in the same connector.

10. Remove the virtual media key from the system board and set it aside. You will have to install the virtual media key on the new system board.
11. Remove the system battery (see “Removing the system battery” on page 415).
12. Disconnect all cables from the system board (see “Internal cable routing and connectors” on page 350). Make a list of each cable as you disconnect it; you can then use this as a checklist when you install the new system board.

Attention: Disengage all latches, release tabs or locks on cable connectors when you disconnect all cables from the system board. Failing to release them before removing the cables will damage the cable sockets on the system board. The cable sockets on the system board are fragile. Any damage to the cable sockets may require replacing the system board.

13. Remove the hot-swap fans (see “Removing a hot-swap fan assembly” on page 396).
14. Press the fan brackets release latches (one is to the left of fan 6 and one is to the right of fan 1) inward toward the fans and rotate the fan assembly brackets up toward the front of the server.
15. Grasp the system board handle and lift up the right side of the system board slightly so that it disengages from the locator pin; then, slide the system board slightly toward the left of the server.

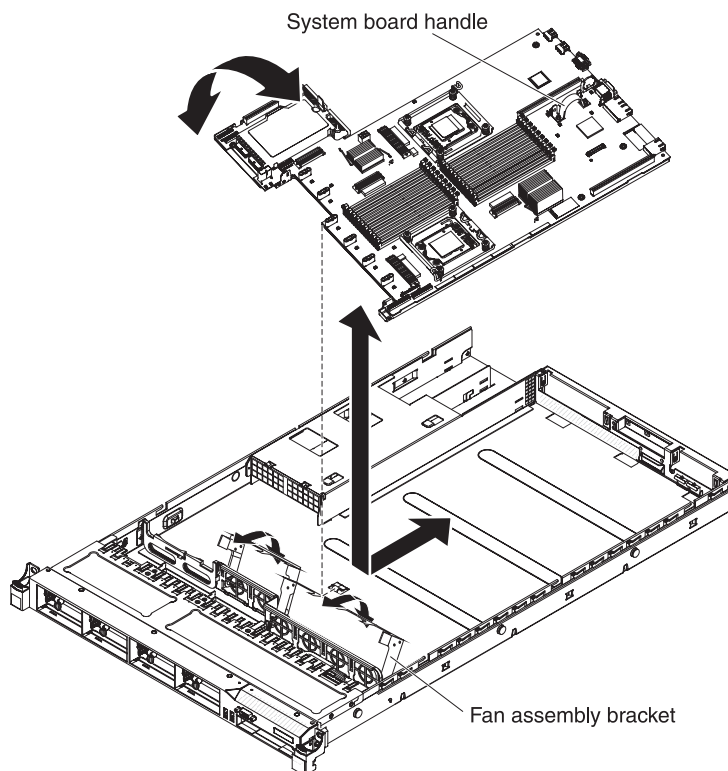

Figure 133. System board removal

16. Lift up the system board and carefully remove it from the server, being careful neither to damage any surrounding components nor to bend the pins inside the microprocessor sockets.
17. Remove the socket dust covers from the microprocessor sockets on the new system board and place them on the microprocessor sockets of the old system board that you are removing.
Attention: Make sure to place the socket covers for the microprocessor sockets on the system board before you return the old system board.

Results

If you are instructed to return the system board, follow all packaging instructions, and use any packaging materials for shipping that are supplied to you.

Installing the system board

Use this information to install the system board.

About this task

Notes:

1. When you reassemble the components in the server, be sure to route all cables carefully so that they are not exposed to excessive pressure.
2. When you replace the system board, you must either update the server with the latest firmware or restore the pre-existing firmware that the customer provides on a diskette or CD image. Make sure that you have the latest firmware or a copy of the pre-existing firmware before you proceed. See “Updating the firmware” on page 455, “Updating the Universal Unique Identifier (UUID)” on page 477, and “Updating the DMI/SMBIOS data” on page 479 for more information.

Important: Some cluster solutions require specific code levels or coordinated code updates. If the device is part of a cluster solution, verify that the latest level of code is supported for the cluster solution before you update the code.

To install the system board, complete the following steps:

Procedure

1. Read the safety information that begins on “Safety” on page vii and “Installation guidelines” on page 347.
2. Align the system board with the chassis; then, lower the system board into the chassis and slide the system board toward the rear of the server until the system board is seated firmly into the locator pins on the chassis.

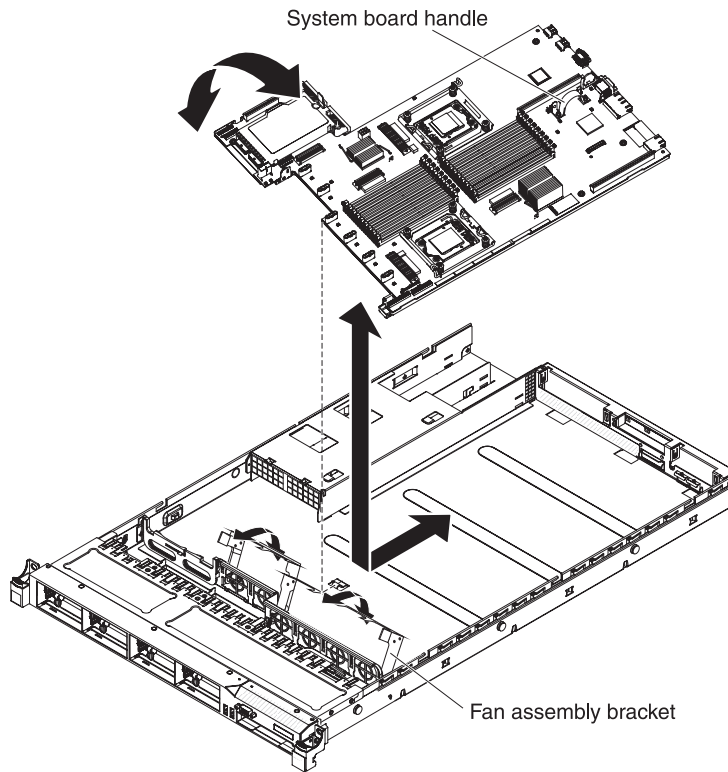

Figure 134. System board installation

3. Grasp the fan assembly brackets and rotate them down toward the chassis.
4. Reinstall the hot-swap fans (see “Installing a hot-swap fan assembly” on page 398).
5. (Trained service technician only) Reinstall the microprocessor and heat sink (see “Installing a microprocessor and heat sink” on page 441).
6. Reinstall the SAS/SATA RAID riser-card assembly base (see “Installing the SAS/SATA RAID riser-card assembly” on page 386).
7. Reinstall the DIMMs (see “Installing a memory module” on page 363).
8. Reinstall the system battery (see “Installing the system battery” on page 417).
9. Reinstall the microprocessor 2 and DIMM air baffles (see “Installing the microprocessor 2 air baffle” on page 359 and “Installing the DIMM air baffle” on page 361).
10. Reinstall the PCI riser-card assemblies and adapters, if any were installed (see “Installing a PCI riser-card assembly” on page 426).
11. Reinstall the virtual media key (see “Installing the virtual media key” on page 407).
12. Reconnect to the system board the cables that you disconnected in step 12 on page 450.
13. Install the cover (see “Installing the cover” on page 357).
14. Push the power supplies back into the server.
15. Slide the server into the rack.
16. Reconnect the power cords and any cables that you removed.
17. Turn on the peripheral devices and the server.

Results

Important:

- Start the Setup utility and reset the configuration.
 - Set the system date and time.
 - Set the power-on password.
 - Reconfigure the server.

See “Using the Setup utility” on page 460 for details.

- Either update the server with the latest RAID firmware or restore the pre-existing firmware from a diskette or CD image.
- Update the UUID (see “Updating the Universal Unique Identifier (UUID)” on page 477).
- Update the DMI/SMBIOS (see “Updating the DMI/SMBIOS data” on page 479).

Chapter 6. Configuration information and instructions

This chapter provides information about updating the firmware and using the configuration utilities.

Updating the firmware

Use this information to update the firmware.

Important:

1. Some cluster solutions require specific code levels or coordinated code updates. If the device is part of a cluster solution, verify that the latest level of code is supported for the cluster solution before you update the code.
2. Before you update the firmware, be sure to back up any data that is stored in the Trusted Platform Module (TPM), in case any of the TPM characteristics are changed by the new firmware. For instructions, see your encryption software documentation.
3. Installing the wrong firmware or device-driver update might cause the server to malfunction. Before you install a firmware or device-driver update, read any readme and change history files that are provided with the downloaded update. These files contain important information about the update and the procedure for installing the update, including any special procedure for updating from an early firmware or device-driver version to the latest version.

You can install code updates that are packaged as an *UpdateXpress* System Pack or *UpdateXpress* CD image. An *UpdateXpress* System Pack contains an integration-tested bundle of online firmware and device-driver updates for your server. Use *UpdateXpress* System Pack Installer to acquire and apply *UpdateXpress* System Packs and individual firmware and device-driver updates. For additional information and to download the *UpdateXpress* System Pack Installer, go to the ToolsCenter for System x and BladeCenter at <http://www.ibm.com/support/entry/portal/docdisplay?lnocid=TOOL-CENTER> and click **UpdateXpress System Pack Installer**.

When you click an update, an information page is displayed, including a list of the problems that the update fixes. Review this list for your specific problem; however, even if your problem is not listed, installing the update might solve the problem.

Be sure to separately install any listed critical updates that have release dates that are later than the release date of the *UpdateXpress* System Pack or *UpdateXpress* image.

The firmware for the server is periodically updated and is available for download from the IBM website. To check for the latest level of firmware, such as UEFI firmware, vital product data (VPD) code, device drivers, and integrated management module firmware, go to <http://www.ibm.com/support/fixcentral/>.

Download the latest firmware for the server; then, install the firmware, using the instructions that are included with the downloaded files.

When you replace a device in the server, you might have to either update the firmware that is stored in memory on the device or restore the pre-existing firmware from a diskette or CD image.

- UEFI firmware is stored in ROM on the system board.
- IMM firmware is stored in ROM on the IMM on the system board.
- Ethernet firmware is stored in ROM on the Ethernet controller.
- ServeRAID firmware is stored in ROM on the ServeRAID adapter.
- SATA firmware is stored in ROM on the integrated SATA controller.
- SAS/SATA firmware is stored in ROM on the SAS/SATA controller on the system board.

Configuring the server

The following configuration programs come with the server:

The *ServerGuide* program provides software-setup tools and installation tools that are designed for the server. Use this CD during the installation of the server to configure basic hardware features, such as an integrated SAS/SATA controller with RAID capabilities, and to simplify the installation of your operating system. For information about using this CD, see “Using the ServerGuide Setup and Installation CD” on page 458.

In addition to the *ServerGuide Setup and Installation CD*, you can use the following configuration programs to customize the server hardware:

- **Setup utility**

The Setup utility is part of the basic input/output system firmware. Use it to change interrupt request (IRQ) settings, change the startup-device sequence, set the date and time, and set passwords. For information about using this program, see “Using the Setup utility” on page 460.

- **Boot Manager program**

The Boot Manager program is part of the server firmware. Use it to override the startup sequence that is set in the Setup utility and temporarily assign a device to be first in the startup sequence. For more information about using this program, see “Using the Boot Manager program” on page 466.

- **Integrated Management Module**

Use the integrated management module (IMM) for configuration, to update the firmware and sensor data record/field replaceable unit (SDR/FRU) data, and to remotely manage a network. For information about using these programs, see “Using the integrated management module” on page 467.

- **VMware ESXi embedded hypervisor**

The VMware ESXi embedded hypervisor is available on the server models that come with an installed USB embedded hypervisor flash device. The USB flash device is installed in the USB connector on the SAS/SATA RAID riser-card. Hypervisor is virtualization software that enables multiple operating systems to run on a host system at the same time. For more information about using the embedded hypervisor, see “Using the embedded hypervisor” on page 470.

- **Remote presence capability and blue-screen capture**

The remote presence and blue-screen capture feature are integrated into the Integrated Management Module (IMM). The virtual media key is required to enable the remote presence functions. When the optional virtual media key is installed in the server, it activates the remote presence functions. Without the virtual media key, you will not be able to access the network remotely to mount

or unmount drives or images on the client system. However, you will still be able to access the host graphical user interface through the Web interface without the Virtual Media Key. You can order the optional IBM Virtual Media Key, if one did not come with your server. For more information about how to enable the remote presence function, see “Using the remote presence capability and blue-screen capture” on page 468.

- **Ethernet controller configuration**

For information about configuring the Ethernet controller, see “Configuring the Gigabit Ethernet controller” on page 472.

- **IBM Advanced Settings Utility (ASU) program**

Use this program as an alternative to the Setup utility for modifying UEFI settings. Use the ASU program online or out of band to modify UEFI settings from the command line without the need to restart the server to access the Setup utility. For more information about using this program, see “IBM Advanced Settings Utility program” on page 475.

- **LSI Configuration Utility program**

Use the LSI Configuration Utility program to configure the integrated SAS/SATA controller with RAID capabilities and the devices that are attached to it. For information about using this program, see “Using the LSI Configuration Utility program” on page 472.

The following table lists the different server configurations and the applications that are available for configuring and managing RAID arrays.

Table 22. Server configuration and applications for configuring and managing RAID arrays

Server configuration	RAID array configuration (before operating system is installed)	RAID array management (after operating system is installed)
ServeRAID-BR10i adapter (LSI 1068E)	LSI Utility (Setup utility, press Ctrl+C), ServerGuide	MegaRAID Storage Manager (for monitoring storage only)
ServeRAID-BR10il v2 adapter (LSI 1064E)	LSI Utility (Setup utility, press Ctrl+C), ServerGuide	MegaRAID Storage Manager (MSM), Director
ServeRAID-MR10i adapter (LSI 1078)	MegaRAID BIOS Configuration Utility (press Ctrl+H to start), ServerGuide	MegaRAID Storage Manager (MSM), Director
ServeRAID-M5014 adapter (LSI SAS2108)	MegaCLI (Command Line Interface), ServerGuide	MegaRAID Storage Manager (MSM), Director
ServeRAID-M5015 adapter (LSI SAS2108)	MegaCLI (Command Line Interface), ServerGuide	MegaRAID Storage Manager (MSM), Director
ServeRAID-M1015 adapter (LSI SAS2008)	MegaCLI (Command Line Interface), ServerGuide	MegaRAID Storage Manager (MSM), Director

Using the ServerGuide Setup and Installation CD

Use this information as an overview for using the ServerGuide Setup and Installation CD.

The *ServerGuide Setup and Installation* CD provides software setup tools and installation tools that are designed for your server. The ServerGuide program detects the server model and hardware options that are installed and uses that information during setup to configure the hardware. The ServerGuide program simplifies operating-system installations by providing updated device drivers and, in some cases, installing them automatically. To download the CD, go to <http://www.ibm.com/support/entry/portal/docdisplay?lnocid=SERV-GUIDE> and click **IBM Service and Support Site**.

The ServerGuide program has the following features:

- An easy-to-use interface
- Diskette-free setup, and configuration programs that are based on detected hardware
- ServeRAID Manager program, which configures your ServeRAID adapter
- Device drivers that are provided for your server model and detected hardware
- Operating-system partition size and file-system type that are selectable during setup

Note: Changes are made periodically to the IBM Web site. The actual procedure might vary slightly from what is described in this document.

ServerGuide features

This information provides an overview of the ServerGuide features.

Features and functions can vary slightly with different versions of the ServerGuide program. To learn more about the version that you have, start the *ServerGuide Setup and Installation* CD and view the online overview. Not all features are supported on all server models.

The ServerGuide program requires a supported IBM server with an enabled startable (bootable) CD drive. In addition to the *ServerGuide Setup and Installation* CD, you must have your operating-system CD to install the operating system.

The ServerGuide program performs the following tasks:

- Sets system date and time
- Detects the RAID adapter or controller and runs the SAS/SATA RAID configuration program
- Checks the microcode (firmware) levels of a ServeRAID adapter and determines whether a later level is available from the CD
- Detects installed hardware options and provides updated device drivers for most adapters and devices
- Provides diskette-free installation for supported Windows operating systems
- Includes an online readme file with links to tips for your hardware and operating-system installation

Setup and configuration overview

ServerGuide setup and configuration overview

When you use the *ServerGuide Setup and Installation* CD, you do not need setup diskettes. You can use the CD to configure any supported IBM server model. The setup program provides a list of tasks that are required to set up your server model. On a server with a ServeRAID adapter or SAS/SATA controller with RAID capabilities, you can run the SAS RAID configuration program to create logical drives.

Note: Features and functions can vary slightly with different versions of the ServerGuide program.

When you start the *ServerGuide Setup and Installation* CD, the program prompts you to complete the following tasks:

- Select your language.
- Select your keyboard layout and country.
- View the overview to learn about ServerGuide features.
- View the readme file to review installation tips for your operating system and adapter.
- Start the operating-system installation. You will need your operating-system CD.

Important: Before you install a legacy operating system (such as VMware) on a server with an LSI SAS controller, you must first complete the following steps:

1. Update the device driver for the LSI SAS controller to the latest level.
2. In the Setup utility, set **Legacy Only** as the first option in the boot sequence in the **Boot Manager** menu.
3. Using the LSI Configuration Utility program, select a boot drive.

For detailed information and instructions, go to <http://www.ibm.com/support/entry/portal/docdisplay?lnocid=MIGR-5083225>.

Typical operating-system installation

ServerGuide typical operating-system installation

The ServerGuide program can reduce the time it takes to install an operating system. It provides the device drivers that are required for your hardware and for the operating system that you are installing. This section describes a typical ServerGuide operating-system installation.

Note: Features and functions can vary slightly with different versions of the ServerGuide program.

1. After you have completed the setup process, the operating-system installation program starts. (You will need your operating-system CD to complete the installation.)
2. The ServerGuide program stores information about the server model, service processor, hard disk drive controllers, and network adapters. Then, the program checks the CD for newer device drivers. This information is stored and then passed to the operating-system installation program.
3. The ServerGuide program presents operating-system partition options that are based on your operating-system selection and the installed hard disk drives.

4. The ServerGuide program prompts you to insert your operating-system CD and restart the server. At this point, the installation program for the operating system takes control to complete the installation.

Installing your operating system without using ServerGuide

Use this information to install the operating system on the server without using ServerGuide.

If you have already configured the server hardware and you are not using the ServerGuide program to install your operating system, go to <http://www.ibm.com/supportportal/> to download the latest operating-system installation instructions from the IBM website.

Using the Setup utility

Use these instructions to start the Setup utility.

Use the Unified Extensible Firmware Interface (UEFI), formerly BIOS, Setup utility to perform the following tasks:

- View configuration information
- View and change assignments for devices and I/O ports
- Set the date and time
- Set the startup characteristics of the server and the order of startup devices
- Set and change settings for advanced hardware features
- View, set, and change settings for power-management features
- View and clear error logs
- Change interrupt request (IRQ) settings
- Resolve configuration conflicts

Starting the Setup utility

Use this information to start the Setup utility.

About this task

To start the Setup utility, complete the following steps:

Procedure

1. Turn on the server.

Note: Approximately 20 to 40 seconds after the server is connected to power, the power-control button becomes active.

2. When the prompt <F1> Setup is displayed, press F1. If you have set an administrator password, you must type the administrator password to access the full Setup utility menu. If you do not type the administrator password, a limited Setup utility menu is available.
3. Select settings to view or change.

Setup utility menu choices

Use the Setup utility main menu to view and configure server configuration data and settings.

The following choices are on the Setup utility main menu for the UEFI. Depending on the version of the firmware, some menu choices might differ slightly from these descriptions.

- **System Information**

Select this choice to view information about the server. When you make changes through other choices in the Setup utility, some of those changes are reflected in the system information; you cannot change settings directly in the system information. This choice is on the full Setup utility menu only.

- **System Summary**

Select this choice to view configuration information, including the ID, speed, and cache size of the microprocessors, machine type and model of the server, the serial number, the system UUID, and the amount of installed memory. When you make configuration changes through other options in the Setup utility, the changes are reflected in the system summary; you cannot change settings directly in the system summary.

- **Product Data**

Select this choice to view the system-board identifier, the revision level or issue date of the firmware, the integrated management module and diagnostics code, and the version and date.

This choice is on the full Setup utility menu only.

- **System Settings**

Select this choice to view or change the server component settings.

- **Processors**

Select this choice to view or change the processor settings.

- **Memory**

Select this choice to view or change the memory settings.

- **Devices and I/O Ports**

Select this choice to view or change assignments for devices and input/output (I/O) ports. You can configure the serial ports, configure remote console redirection, enable or disable integrated Ethernet controllers, the SAS/SATA controller, SATA optical drive channels, PCI slots, and video controller. If you disable a device, it cannot be configured, and the operating system will not be able to detect it (this is equivalent to disconnecting the device).

- **Power**

Select this choice to view or change power capping to control consumption, processors, and performance states.

- **Operating Modes**

Select this choice to view or change the operating profile (performance and power utilization).

- **Legacy Support**

Select this choice to view or set legacy support.

- **Force Legacy Video on Boot**

Select this choice to force INT video support, if the operating system does not support UEFI video output standards.

- **Rehook INT 19h**

Select this choice to enable or disable devices from taking control of the boot process. The default is **Disable**.

- **Legacy Thunk Support**

Select this choice to enable or disable UEFI to interact with PCI mass storage devices that are non-UEFI compliant.

- **Integrated Management Module**

Select this choice to view or change the settings for the integrated management module.

- **POST Watchdog Timer**

Select this choice to view or enable the POST watchdog timer.

- **POST Watchdog Timer Value**

Select this choice to view or set the POST loader watchdog timer value.

- **Reboot System on NMI**

Enable or disable restarting the system whenever a nonmaskable interrupt (NMI) occurs. **Disabled** is the default.

- **Commands on USB Interface Preference**

Select this choice to enable or disable the Ethernet over USB interface on IMM.

- **Network Configuration**

Select this choice to view the system management network interface port, the IMM MAC address, the current IMM IP address, and host name; define the static IMM IP address, subnet mask, and gateway address, specify whether to use the static IP address or have DHCP assign the IMM IP address, save the network changes, and reset the IMM.

- **Reset IMM to Defaults**

Select this choice to view or reset IMM to the default settings.

- **Reset IMM**

Select this choice to reset IMM.

- **System Security**

Select this choice to view or configure Trusted Platform Module (TPM) support.

- **Adapters and UEFI Drivers**

Select this choice to view information about the UEFI 1.10 and UEFI 2.0 compliant adapters and drivers installed in the server.

- **Video**

Select this choice to view or configure the video device options.

Note: The configuration forms for UEFI 2.1 and greater compliant add-on video devices might be located here.

- **Date and Time**

Select this choice to set the date and time in the server, in 24-hour format (*hour:minute:second*).

This choice is on the full Setup utility menu only.

- **Start Options**

Select this choice to view or change the start options, including the startup sequence, keyboard NumLock state, PXE boot option, and PCI device boot priority. Changes in the startup options take effect when you start the server.

The startup sequence specifies the order in which the server checks devices to find a boot record. The server starts from the first boot record that it finds. If the server has Wake on LAN hardware and software and the operating system supports Wake on LAN functions, you can specify a startup sequence for the Wake on LAN functions. For example, you can define a startup sequence that checks for a disc in the CD-RW/DVD drive, then checks the hard disk drive, and then checks a network adapter.

This choice is on the full Setup utility menu only.

- **Boot Manager**

Select this choice to view, add, delete, or change the device boot priority, boot from a file, select a one-time boot, or reset the boot order to the default setting.

- **System Event Logs**

Select this choice to enter the System Event Manager, where you can view the error messages in the system event logs. You can use the arrow keys to move between pages in the error log.

The system event logs contain all event and error messages that have been generated during POST, by the systems-management interface handler, and by the system service processor. Run the diagnostic programs to get more information about error codes that occur.

Important: If the system-error LED on the front of the server is lit but there are no other error indications, clear the IMM system-event log. Also, after you complete a repair or correct an error, clear the IMM system-event log to turn off the system-error LED on the front of the server.

- **POST Event Viewer**

Select this choice to enter the POST event viewer to view the POST error messages.

- **System Event Log**

Select this choice to view the IMM system event log.

- **Clear System Event Log**

Select this choice to clear the IMM system event log.

- **User Security**

Select this choice to set, change, or clear passwords. See “Passwords” on page 464 for more information.

This choice is on the full and limited Setup utility menu.

- **Set Power-on Password**

Select this choice to set or change a power-on password. For more information, see “Power-on password” on page 464 for more information.

- **Clear Power-on Password**

Select this choice to clear a power-on password. For more information, see “Power-on password” on page 464 for more information.

- **Set Administrator Password**

Select this choice to set or change an administrator password. An administrator password is intended to be used by a system administrator; it limits access to the full Setup utility menu. If an administrator password is set, the full Setup utility menu is available only if you type the administrator password at the password prompt. For more information, see “Administrator password” on page 466.

- **Clear Administrator Password**

Select this choice to clear an administrator password. For more information, see “Administrator password” on page 466.

- **Save Settings**
Select this choice to save the changes that you have made in the settings.
- **Restore Settings**
Select this choice to cancel the changes that you have made in the settings and restore the previous settings.
- **Load Default Settings**
Select this choice to cancel the changes that you have made in the settings and restore the factory settings.
- **Exit Setup**
Select this choice to exit from the Setup utility. If you have not saved the changes that you have made in the settings, you are asked whether you want to save the changes or exit without saving them.

Passwords

From the **User Security** menu choice, you can set, change, and delete a power-on password and an administrator password.

The **User Security** choice is on the full Setup utility menu only.

If you set only a power-on password, you must type the power-on password to complete the system startup and to have access to the full Setup utility menu.

An administrator password is intended to be used by a system administrator; it limits access to the full Setup utility menu. If you set only an administrator password, you do not have to type a password to complete the system startup, but you must type the administrator password to access the Setup utility menu.

If you set a power-on password for a user and an administrator password for a system administrator, you must type the power-on password to complete the system startup. A system administrator who types the administrator password has access to the full Setup utility menu; the system administrator can give the user authority to set, change, and delete the power-on password. A user who types the power-on password has access to only the limited Setup utility menu; the user can set, change, and delete the power-on password, if the system administrator has given the user that authority.

Power-on password:

If a power-on password is set, when you turn on the server, you must type the power-on password to complete the system startup. You can use any combination of 6 - 20 printable ASCII characters for the password.

When a power-on password is set, you can enable the Unattended Start mode, in which the keyboard and mouse remain locked but the operating system can start. You can unlock the keyboard and mouse by typing the power-on password.

If you forget the power-on password, you can regain access to the server in any of the following ways:

- If an administrator password is set, type the administrator password at the password prompt. Start the Setup utility and reset the power-on password.
- Remove the battery from the server and then reinstall it.

- Change the position of the power-on password switch (enable switch 1 of the system board switch block (SW4) to bypass the power-on password check (see Table 6 on page 21 for more information).

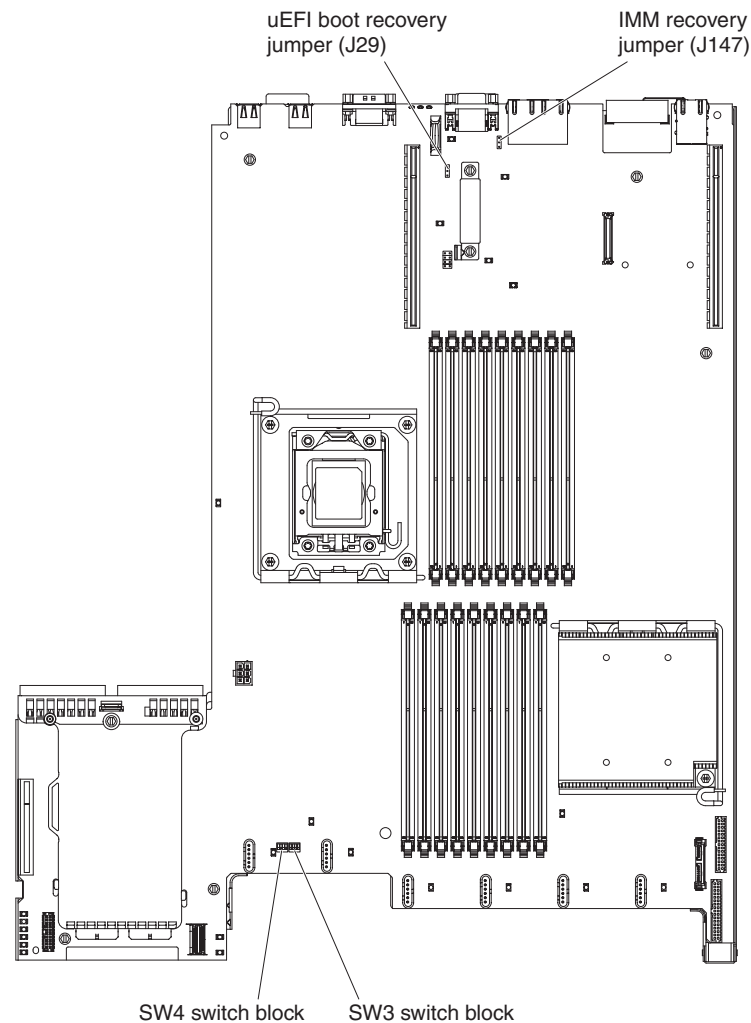

Figure 135. System-board switches and jumpers

Attention: Before you change any switch settings or move any jumpers, turn off the server; then, disconnect all power cords and external cables. See the safety information that begins “Safety” on page vii. Do not change settings or move jumpers on any system-board switch or jumper blocks that are not shown in this document.

The default for all of the switches on switch block (SW4) is Off.

While the server is turned off, move switch 1 of the switch block (SW4) to the On position to enable the power-on password override. You can then start the Setup utility and reset the power-on password. You do not have to return the switch to the previous position.

The power-on password override switch does not affect the administrator password.

Administrator password:

If an administrator password is set, you must type the administrator password for access to the full Setup utility menu. You can use any combination of 6 to 20 printable ASCII characters for the password.

Attention: If you set an administrator password and then forget it, there is no way to change, override, or remove it. You must replace the system board.

Using the Boot Manager program

The Boot Manager program is a built-in, menu-driven configuration utility program that you can use to temporarily redefine the first startup device without changing settings in the Setup utility.

About this task

To use the Boot Manager program, complete the following steps:

Procedure

1. Turn off the server.
2. Restart the server.
3. When the prompt <F12> Select Boot Device is displayed, press F12. If a bootable USB mass storage device is installed, a submenu item (**USB Key/Disk**) is displayed.
4. Use the Up arrow and Down arrow keys to select an item from the **Boot Selection Menu** and press Enter.

Results

The next time the server starts, it returns to the startup sequence that is set in the Setup utility.

Starting the backup server firmware

The system board contains a backup copy area for the server firmware. This is a secondary copy of the server firmware that you update only during the process of updating the server firmware. If the primary copy of the server firmware becomes damaged, use this backup copy.

The system board contains a backup copy area for the server firmware (formerly BIOS firmware). This is a secondary copy of the server firmware that you update only during the process of updating the server firmware. If the primary copy of the server firmware becomes damaged, use this backup copy.

To force the server to start from the backup copy of the server firmware, turn off the server; then, place the J29 jumper in the backup position (pins 2 and 3).

Use the backup copy of the server firmware until the primary copy is restored. After the primary copy is restored, turn off the server; then, move the J29 jumper back to the primary position (pins 1 and 2).

Using the integrated management module

The integrated management module (IMM) is a second generation of the functions that were formerly provided by the baseboard management controller hardware. It combines service processor functions, video controller, and remote presence function in a single chip.

The IMM supports the following basic system management features:

- Environmental monitor with fan speed control for temperature, voltages, fan failure, and power supply failure.
- Light path diagnostics LEDs indicators to report errors that occur with fans, power supplies, microprocessor, hard disk drives, and system errors.
- DIMM error assistance. The Unified Extensible Firmware Interface (UEFI) disables a failing DIMM that is detected during POST, and the IMM lights the associated system error LED and the failing DIMM error LED.
- System event log (SEL).
- ROM-based IMM firmware flash updates.
- Auto Boot Failure Recovery (ABR).
- A virtual media key, which enables remote presence support (remote video, remote keyboard/mouse, and remote storage).
- Automatic microprocessor disable on failure and restart in a two-microprocessor configuration when one microprocessor signals an internal error.
- Nonmaskable interrupt (NMI) detection and reporting.
- Automatic Server Restart (ASR) when POST is not complete or the operating system hangs and the operating system watchdog timer times-out. The IMM might be configured to watch for the operating system watchdog timer and reboot the system after a timeout, if the ASR feature is enabled. Otherwise, the IMM allows the administrator to generate a nonmaskable interrupt (NMI) by pressing an NMI button on the light path diagnostics panel for an operating-system memory dump. ASR is supported by IPMI.
- Intelligent Platform Management Interface (IPMI) Specification V2.0 and Intelligent Platform Management Bus (IPMB) support.
- Invalid system configuration (CNFG) LED support.
- Serial port redirection over telnet or ssh.
- Serial over LAN (SOL).
- Active Energy Manager
- Query power-supply input power.
- PECI 2 support.
- Power/reset control (power-on, hard and soft shutdown, hard and soft reset, schedule power control).
- Alerts (in-band and out-of-band alerting, PET traps - IPMI style, SNMP, e-mail).
- Operating-system failure blue screen capture.
- Command-line interface.
- Configuration save and restore.
- PCI configuration data.
- Boot sequence manipulation.

The IMM also provides the following remote server management capabilities through the OSA SMBridge management utility program:

- **Command-line interface (IPMI Shell)**

The command-line interface provides direct access to server management functions through the IPMI 2.0 protocol. Use the command-line interface to issue commands to control the server power, view system information, and identify the server. You can also save one or more commands as a text file and run the file as a script.

- **Serial over LAN**

Establish a Serial over LAN (SOL) connection to manage servers from a remote location. You can remotely view and change the UEFI settings, restart the server, identify the server, and perform other management functions. Any standard Telnet client application can access the SOL connection.

Using the remote presence capability and blue-screen capture

The remote presence and blue-screen capture features are integrated functions of the integrated management module (IMM).

When the optional IBM Virtual Media Key is installed in the server, it activates the remote presence functions. The virtual media key is required to enable the integrated remote presence and blue-screen capture features. Without the virtual media key, you will not be able to access the network remotely to mount or unmount drives or images on the client system. However, you can still access the Web interface without the key.

After the virtual media key is installed in the server, it is authenticated to determine whether it is valid. If the key is not valid, you receive a message from the Web interface (when you attempt to start the remote presence feature) indicating that the hardware key is required to use the remote presence feature.

The virtual media key has an LED. When this LED is lit and green, it indicates that the key is installed and functioning correctly. When the LED is not lit, it indicates that the key might not be installed correctly.

The remote presence feature provides the following functions:

- Remotely viewing video with graphics resolutions up to 1600 x 1200 at 75 Hz, regardless of the system state
- Remotely accessing the server, using the keyboard and mouse from a remote client
- Mapping the CD or DVD drive, diskette drive, and USB flash drive on a remote client, and mapping ISO and diskette image files as virtual drives that are available for use by the server
- Uploading a diskette image to the IMM memory and mapping it to the server as a virtual drive

The blue-screen capture feature captures the video display contents before the IMM restarts the server when the IMM detects an operating-system hang condition. A system administrator can use the blue-screen capture to assist in determining the cause of the hang condition.

Enabling the remote presence feature

Use this information to enable the remote presence feature.

About this task

To enable the remote presence feature, complete the following steps:

Procedure

1. Install the virtual media key into the dedicated slot on the system board (see “System-board optional device connectors” on page 23).
2. Turn on the server.

Note: Approximately 20 to 40 seconds after the server is connected to power, the power-control button becomes active.

Obtaining the IP address for the IMM

To access the web interface, you need the IP address for IMM. You can obtain the IMM IP address through the Setup utility. The server comes with a default IP address for the IMM of 192.168.70.125.

About this task

To locate the IP address, complete the following steps:

Procedure

1. Turn on the server.

Note: Approximately 20 to 40 seconds after the server is connected to power, the power-control button becomes active.

2. When the prompt <F1> Setup is displayed, press F1. (This prompt is displayed on the screen for only a few seconds. You must press F1 quickly.) If you have set both a power-on password and an administrator password, you must type the administrator password to access the full Setup utility menu.
3. From the Setup utility main menu, select **System Settings**.
4. On the next screen, select **Integrated Management Module**.
5. On the next screen, select **Network Configuration**.
6. Find the IP address and write it down.
7. Exit from the Setup utility.

Logging on to the Web interface

Use this information to log on to the web interface.

About this task

To log onto the Web interface to use the remote presence functions, complete the following steps:

Procedure

1. Open a Web browser on a computer that connects to the server and in the **Address** or **URL** field, type the IP address or host name of the IMM to which you want to connect.

Note: The IMM defaults to DHCP. If a DHCP host is not available, the IMM assigns a static IP address of 192.168.70.125.

2. On the Login page, type the user name and password. If you are using the IMM for the first time, you can obtain the user name and password from your system administrator. All login attempts are documented in the event log.

Note: The IMM is set initially with a user name of USERID and password of PASSWORD (passw0rd with a zero, not the letter O). You have read/write access. You must change the default password the first time you log on.

3. On the Welcome page, type a timeout value (in minutes) in the field that is provided. The IMM will log you off of the Web interface if your browser is inactive for the number of minutes that you entered for the timeout value.
4. Click **Continue** to start the session. The System Health page provides a quick view of the system status.

Using the embedded hypervisor

The VMware ESXi embedded hypervisor is available on server models that come with an installed USB embedded hypervisor flash device.

About this task

The USB flash device comes installed in the USB connector on the SAS/SATA RAID riser card (see the following illustration). Hypervisor is virtualization software that enables multiple operating systems to run on a host system at the same time. The USB flash device is required to activate the hypervisor functions.

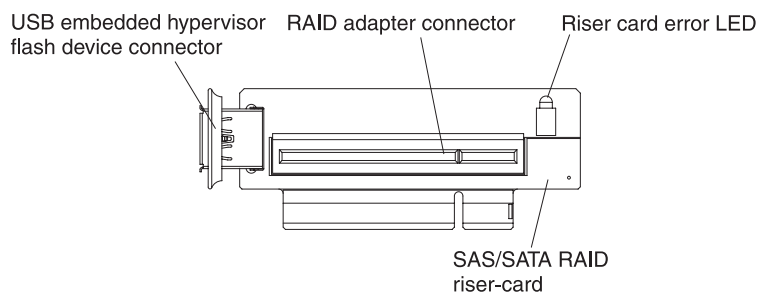

Figure 136. USB embedded hypervisor flash device connector

To start using the embedded hypervisor functions, you must add the USB flash device to the boot order in the Setup utility.

To add the USB flash device to the boot order, complete the following steps:

Procedure

1. Turn on the server.

Note: Approximately 20 to 40 seconds after the server is connected to power, the power-control button becomes active.

2. When the prompt <F1> Setup is displayed, press F1.
3. From the Setup utility main menu, select **Boot Manager**.
4. Select **Add Boot Option > Embedded Hypervisor**. Press Enter, and then select Esc.
5. Select **Change Boot Order** and then select **Commit Changes**; then, press Enter.
6. Select **Save Settings** and then select **Exit Setup**.

Recovering the flash device image

About this task

If the embedded hypervisor flash device image becomes corrupt, you can use the *VMware Recovery* CD to recover the flash device image.

To recover the flash device image, complete the following steps:

Procedure

1. Turn on the server.

Note: Approximately 20 to 40 seconds after the server is connected to power, the power-control button becomes active.

2. Insert the VMware Recovery CD into the CD or DVD drive.
3. Follow the instructions on the screen.

Results

For additional information and instructions, see the *ESXi Embedded and vCenter Server Setup Guide* at http://www.vmware.com/pdf/vsphere4/r40_u1/vsp_40_u1_esxi_e_vc_setup_guide.pdf.

Enabling the Broadcom Gigabit Ethernet Utility program

The Broadcom Gigabit Ethernet Utility program is part of the server firmware.

You can use it to configure the network as a startable device, and you can customize where the network startup option appears in the startup sequence. Enable and disable the Broadcom Gigabit Ethernet Utility program from the Setup utility.

Configuring the Gigabit Ethernet controller

The Ethernet controllers are integrated on the system board. They provide an interface for connecting to a 10 Mbps, 100 Mbps, or 1 Gbps network and provide full-duplex (FDX) capability, which enables simultaneous transmission and reception of data on the network.

If the Ethernet ports in the server support auto-negotiation, the controllers detect the data-transfer rate (10BASE-T, 100BASE-TX, or 1000BASE-T) and duplex mode (full-duplex or half-duplex) of the network and automatically operate at that rate and mode.

You do not have to set any jumpers or configure the controllers. However, you must install a device driver to enable the operating system to address the controllers.

To find device drivers and information about configuring the Ethernet controllers, go to <http://www.ibm.com/supportportal/>.

Using the LSI Configuration Utility program

Use the LSI Configuration Utility program to configure and manage redundant array of independent disks (RAID) arrays.

Be sure to use this program as described in this document.

- Use the LSI Configuration Utility program to perform the following tasks:
 - Perform a low-level format on a hard disk drive
 - Create an array of hard disk drives with or without a hot-spare drive
 - Set protocol parameters on hard disk drives

The integrated SAS/SATA controller with RAID capabilities supports RAID arrays. You can use the LSI Configuration Utility program to configure RAID 1 (IM), RAID 1E (IME), and RAID 0 (IS) for a single pair of attached devices. If you install the optional ServeRAID-MR10i SAS/SATA controller, it provides RAID levels 0, 1, 5, 6, 10, 50, and 60 support. If you install a different type of RAID adapter, follow the instructions in the documentation that comes with the adapter to view or change settings for attached devices.

In addition, you can download an LSI command-line configuration program from <http://www.ibm.com/supportportal/>.

When you are using the LSI Configuration Utility program to configure and manage arrays, consider the following information:

- The integrated SAS/SATA controller with RAID capabilities supports the following features:
 - Integrated Mirroring (IM) with hot-spare support (also known as RAID 1)
Use this option to create an integrated array of two disks plus up to two optional hot spares. All data on the primary disk can be migrated.
 - Integrated Mirroring Enhanced (IME) with hot-spare support (also known as RAID 1E)
Use this option to create an integrated mirror enhanced array of three to eight disks, including up to two optional hot spares. All data on the array disks will be deleted.
 - Integrated Striping (IS) (also known as RAID 0)

Use this option to create an integrated striping array of two to eight disks. All data on the array disks will be deleted.

- Hard disk drive capacities affect how you create arrays. The drives in an array can have different capacities, but the RAID controller treats them as if they all have the capacity of the smallest hard disk drive.
- If you use an integrated SAS/SATA controller with RAID capabilities to configure a RAID 1 (mirrored) array after you have installed the operating system, you will lose access to any data or applications that were previously stored on the secondary drive of the mirrored pair.
- If you install a different type of RAID controller, see the documentation that comes with the controller for information about viewing and changing settings for attached devices.

Starting the LSI Configuration Utility program

Use this information to start the LSI Configuration Utility program.

About this task

To start the LSI Configuration Utility program, complete the following steps:

Procedure

1. Turn on the server.

Note: Approximately 20 to 40 seconds after the server is connected to power, the power-control button becomes active.

2. When the prompt <F1 Setup> is displayed, press F1. If you have set an administrator password, you are prompted to type the password.
3. Select **System Settings > Adapters and UEFI drivers**.
4. Select **Please refresh this page on the first visit** and press Enter.
5. Select **LSI controller_driver_name Driver** and press Enter, where *controller_driver_name* is the name of the SAS/SATA controller driver. For the SAS/SATA controller driver name, see the documentation that comes with your controller.
6. To perform storage-management tasks, follow the procedures in the documentation that comes with the SAS/SATA controller.

Results

When you have finished changing settings, press Esc to exit from the program; select **Save** to save the settings that you have changed.

Formatting a hard disk drive

Low-level formatting removes all data from the hard disk. If there is data on the disk that you want to save, back up the hard disk before you perform this procedure.

About this task

Note: Before you format a hard disk, make sure that the disk is not part of a mirrored pair.

To format a drive, complete the following steps:

Procedure

1. From the list of adapters, select the controller (channel) for the drive that you want to format and press Enter.
2. Select **SAS Topology** and press Enter.
3. Select **Direct Attach Devices** and press Enter.
4. To highlight the drive that you want to format, use the Up Arrow and Down Arrow keys. To scroll left and right, use the Left Arrow and Right Arrow keys or the End key. Press Alt+D.
5. To start the low-level formatting operation, select **Format** and press Enter.

Creating a RAID array of hard disk drives

Use this information to create a RAID array of hard disk drives.

About this task

To create a RAID array of hard disk drives, complete the following steps:

Procedure

1. From the list of adapters, select the controller (channel) for the drives that you want to mirror.
2. Select **RAID Properties**.
3. Select the type of array that you want to create.
4. Use the arrow keys to highlight the first drive in the pair; then, press the Minus (-) or Plus (+) key to change the mirror value to **Primary**.
5. Continue to select the next drive using the Minus (-) or Plus (+) key until you have selected all the drives for your array.
6. Press C to create the disk array.
7. Select **Apply changes and exit menu** to create the array.

IBM Advanced Settings Utility program

The IBM Advanced Settings Utility (ASU) program is an alternative to the Setup utility for modifying UEFI settings.

Use the ASU program online or out of band to modify UEFI settings from the command line without the need to restart the system to access the Setup utility.

You can also use the ASU program to configure the optional remote presence features or other IMM settings. The remote presence features provide enhanced systems-management capabilities.

In addition, the ASU program provides limited settings for configuring the IPMI function in the IMM through the command-line interface.

Use the command-line interface to issue setup commands. You can save any of the settings as a file and run the file as a script. The ASU program supports scripting environments through a batch-processing mode.

For more information and to download the ASU program, go to <http://www.ibm.com/support/entry/portal/docdisplay?lnocid=TOOL-ASU>.

Updating IBM Systems Director

If you plan to use IBM Systems Director to manage the server, you must check for the latest applicable IBM Systems Director updates and interim fixes.

About this task

Note: Changes are made periodically to the IBM website. The actual procedure might vary slightly from what is described in this document.

Installing a newer version

About this task

To locate and install a newer version of IBM Systems Director, complete the following steps:

Procedure

1. Check for the latest version of IBM Systems Director:
 - a. Go to <http://www.ibm.com/systems/management/director/downloads.html>.
 - b. If a newer version of IBM Systems Director than what comes with the server is shown in the drop-down list, follow the instructions on the web page to download the latest version.
2. Install the IBM Systems Director program.

Installing updates with your management server is connected to the Internet

About this task

If your management server is connected to the Internet, to locate and install updates and interim fixes, complete the following steps:

Procedure

1. Make sure that you have run the Discovery and Inventory collection tasks.
2. On the Welcome page of the IBM Systems Director web interface, click **View updates**.
3. Click **Check for updates**. The available updates are displayed in a table.
4. Select the updates that you want to install, and click **Install** to start the installation wizard.

Installing updates with your management server is not connected to the Internet

About this task

If your management server is not connected to the Internet, to locate and install updates and interim fixes, complete the following steps:

Procedure

1. Make sure that you have run the Discovery and Inventory collection tasks.
2. On a system that is connected to the Internet, go to <http://www.ibm.com/support/fixcentral/>.
3. From the **Product family** list, select **IBM Systems Director**.
4. From the **Product** list, select **IBM Systems Director**.
5. From the **Installed version** list, select the latest version, and click **Continue**.
6. Download the available updates.
7. Copy the downloaded files to the management server.
8. On the management server, on the Welcome page of the IBM Systems Director web interface, click the **Manage** tab, and click **Update Manager**.
9. Click **Import updates** and specify the location of the downloaded files that you copied to the management server.
10. Return to the Welcome page of the Web interface, and click **View updates**.
11. Select the updates that you want to install, and click **Install** to start the installation wizard.

Updating the Universal Unique Identifier (UUID)

The Universal Unique Identifier (UUID) must be updated when the system board is replaced. Use the Advanced Settings Utility to update the UUID in the UEFI-based server.

About this task

The ASU is an online tool that supports several operating systems. Make sure that you download the version for your operating system. You can download the ASU from the IBM website. To download the ASU and update the UUID, go to <http://www.ibm.com/support/entry/portal/docdisplay?lnid=TOOL-ASU>.

Procedure

1. ASU sets the UUID in the Integrated Management Module (IMM). Select one of the following methods to access the Integrated Management Module (IMM) to set the UUID:
 - Online from the target system (LAN or keyboard console style (KCS) access)
 - Remote access to the target system (LAN based)
 - Bootable media containing ASU (LAN or KCS, depending upon the bootable media)
2. Copy and unpack the ASU package, which also includes other required files, to the server. Make sure that you unpack the ASU and the required files to the same directory. In addition to the application executable (asu or asu64), the following files are required:
 - For Windows based operating systems:
 - `ibm_rndis_server_os.inf`
 - `device.cat`
 - For Linux based operating systems:
 - `cdc_interface.sh`
3. After you install ASU, use the following command syntax to set the UUID:
`asu set SYSTEM_PROD_DATA.SysInfoUUID <uuid_value> [access_method]`
Where:

<uuid_value>

Up to 16-byte hexadecimal value assigned by you.

[access_method]

The access method that you selected to use from the following methods:

- Online authenticated LAN access, type the command:

`[host <imm_internal_ip>] [user <imm_user_id>] [password <imm_password>]`

Where:

imm_internal_ip

The IMM internal LAN/USB IP address. The default value is 169.254.95.118.

imm_user_id

The IMM account (1 of 12 accounts). The default value is USERID.

imm_password

The IMM account password (1 of 12 accounts). The default value is PASSWORD (with a zero 0 not an O).

Note: If you do not specify any of these parameters, ASU will use the default values. When the default values are used and ASU is unable to access the IMM using the online authenticated LAN access method, ASU will automatically use the unauthenticated KCS access method.

The following commands are examples of using the userid and password default values and not using the default values:

Example that does not use the userid and password default values:
asu set SYSTEM_PROD_DATA.SysInfoUUID <uuid_value> --user <user_id>
--password <password>

Example that does use the userid and password default values:
asu set SYSTEM_PROD_DATA.SysInfoUUID <uuid_value>

- Online KCS access (unauthenticated and user restricted):

You do not need to specify a value for *access_method* when you use this access method.

Example:

```
asu set SYSTEM_PROD_DATA.SysInfoUUID <uuid_value>
```

The KCS access method uses the IPMI/KCS interface. This method requires that the IPMI driver be installed. Some operating systems have the IPMI driver installed by default. ASU provides the corresponding mapping layer. See “IBM Advanced Settings Utility program” on page 475 or the *Advanced Settings Utility Users Guide* for more details.

- Remote LAN access, type the command:

Note: When using the remote LAN access method to access IMM using the LAN from a client, the *host* and the *imm_external_ip* address are required parameters.

```
host <imm_external_ip> [user <imm_user_id>][password <imm_password>]
```

Where:

imm_external_ip

The external IMM LAN IP address. There is no default value. This parameter is required.

imm_user_id

The IMM account (1 of 12 accounts). The default value is USERID.

imm_password

The IMM account password (1 of 12 accounts). The default value is PASSWORD (with a zero 0 not an O).

The following commands are examples of using the userid and password default values and not using the default values:

Example that does not use the userid and password default values:
asu set SYSTEM_PROD_DATA.SysInfoUUID <uuid_value> --host <imm_ip>
--user <user_id> --password <password>

Example that does use the userid and password default values:
asu set SYSTEM_PROD_DATA.SysInfoUUID <uuid_value> --host <imm_ip>

- Bootable media:

You can also build a bootable media using the applications available through the Tools Center website at <http://www.ibm.com/support/entry/portal/>

docdisplay?Indocid=TOOL-CENTER. From the left pane, click **IBM System x and BladeCenter Tools Center**, then click **Tool reference** for the available tools.

4. Restart the server.

Updating the DMI/SMBIOS data

The Desktop Management Interface (DMI) must be updated when the system board is replaced. Use the Advanced Settings Utility to update the DMI in the UEFI-based server.

About this task

The ASU is an online tool that supports several operating systems. Make sure that you download the version for your operating system. You can download the ASU from the IBM website. To download the ASU and update the DMI, go to <http://www.ibm.com/support/entry/portal/docdisplay?Indocid=TOOL-ASU>.

Procedure

1. ASU sets the DMI in the Integrated Management Module (IMM). Select one of the following methods to access the Integrated Management Module (IMM) to set the DMI:
 - Online from the target system (LAN or keyboard console style (KCS) access)
 - Remote access to the target system (LAN based)
 - Bootable media containing ASU (LAN or KCS, depending upon the bootable media)
2. Copy and unpack the ASU package, which also includes other required files, to the server. Make sure that you unpack the ASU and the required files to the same directory. In addition to the application executable (asu or asu64), the following files are required:
 - For Windows based operating systems:
 - ibm_rndis_server_os.inf
 - device.cat
 - For Linux based operating systems:
 - cdc_interface.sh
3. After you install ASU, Type the following commands to set the DMI:

```
asu set SYSTEM_PROD_DATA.SysInfoProdName <m/t_model> [access_method]
asu set SYSTEM_PROD_DATA.SysInfoProdIdentifier <system model> [access_method]
asu set SYSTEM_PROD_DATA.SysInfoSerialNum <s/n> [access_method]
asu set SYSTEM_PROD_DATA.SysEncloseAssetTag <asset_tag> [access_method]
```

Where:

<m/t_model>

The server machine type and model number. Type *mtm xxxxyyy*, where *xxxx* is the machine type and *yyy* is the server model number.

< system model>

The system model. Type *system yyyyyyy*, where *yyyyyyy* is the product identifier such as *x3550M3*.

<s/n>

The serial number on the server. Type *sn zzzzzzz*, where *zzzzzzz* is the serial number.

<asset_method>

The server asset tag number. Type asset
aaaaaaaaaaaaaaaaaaaaaaaaaaaaaa, where
aaaaaaaaaaaaaaaaaaaaaaaaaaaaaa is the asset tag number.

[access_method]

The access method that you select to use from the following methods:

- Online authenticated LAN access, type the command:

```
[host <imm_internal_ip>] [user <imm_user_id>] [password <imm_password>]
```

Where:

imm_internal_ip

The IMM internal LAN/USB IP address. The default value is
169.254.95.118.

imm_user_id

The IMM account (1 of 12 accounts). The default value is USERID.

imm_password

The IMM account password (1 of 12 accounts). The default value is
PASSWORD (with a zero 0 not an O).

Note: If you do not specify any of these parameters, ASU will use the default values. When the default values are used and ASU is unable to access the IMM using the online authenticated LAN access method, ASU will automatically use the following unauthenticated KCS access method.

The following commands are examples of using the userid and password default values and not using the default values:

Examples that do not use the userid and password default values:

```
asu set SYSTEM_PROD_DATA.SysInfoProdName <m/t_model>  
--user <imm_user_id> --password <imm_password>  
asu set SYSTEM_PROD_DATA.SysInfoProdIdentifier <system model>  
--user <imm_user_id> --password <imm_password>  
asu set SYSTEM_PROD_DATA.SysInfoSerialNum <s/n> --user <imm_user_id>  
--password <imm_password>  
asu set SYSTEM_PROD_DATA.SysEncloseAssetTag <asset_tag>  
--user <imm_user_id> --password <imm_password>
```

Examples that do use the userid and password default values:

```
asu set SYSTEM_PROD_DATA.SysInfoProdName <m/t_model>  
asu set SYSTEM_PROD_DATA.SysInfoProdIdentifier <system model>  
asu set SYSTEM_PROD_DATA.SysInfoSerialNum <s/n>  
asu set SYSTEM_PROD_DATA.SysEncloseAssetTag <asset_tag>
```

- Online KCS access (unauthenticated and user restricted):

You do not need to specify a value for *access_method* when you use this access method.

The KCS access method uses the IPMI/KCS interface. This method requires that the IPMI driver be installed. Some operating systems have the IPMI driver installed by default. ASU provides the corresponding mapping layer. See the *Advanced Settings Utility Users Guide* at <http://www.ibm.com/support/entry/portal/docdisplay?lnocid=TOOL-ASU> for more details.

The following commands are examples of using the userid and password default values and not using the default values:

Examples that do not use the userid and password default values:

```
asu set SYSTEM_PROD_DATA.SysInfoProdName <m/t_model>
asu set SYSTEM_PROD_DATA.SysInfoProdIdentifier <system model>
asu set SYSTEM_PROD_DATA.SysInfoSerialNum <s/n>
asu set SYSTEM_PROD_DATA.SysEncloseAssetTag <asset_tag>
```

- Remote LAN access, type the command:

Note: When using the remote LAN access method to access IMM using the LAN from a client, the *host* and the *imm_external_ip* address are required parameters.

```
host <imm_external_ip> [user <imm_user_id>][password <imm_password>]
```

Where:

imm_external_ip

The external IMM LAN IP address. There is no default value. This parameter is required.

imm_user_id

The IMM account (1 of 12 accounts). The default value is USERID.

imm_password

The IMM account password (1 of 12 accounts). The default value is PASSWORD (with a zero 0 not an O).

The following commands are examples of using the userid and password default values and not using the default values:

Examples that do not use the userid and password default values:

```
asu set SYSTEM_PROD_DATA.SysInfoProdName <m/t_model> --host <imm_ip>
--user <imm_user_id> --password <imm_password>
asu set SYSTEM_PROD_DATA.SysInfoProdIdentifier <system model> --host <imm_ip>
--user <imm_user_id> --password <imm_password>
asu set SYSTEM_PROD_DATA.SysInfoSerialNum <s/n> --host <imm_ip>
--user <imm_user_id> --password <imm_password>
asu set SYSTEM_PROD_DATA.SysEncloseAssetTag <asset_tag> --host <imm_ip>
--user <imm_user_id> --password <imm_password>
```

Examples that do use the userid and password default values:

```
asu set SYSTEM_PROD_DATA.SysInfoProdName <m/t_model> --host <imm_ip>
asu set SYSTEM_PROD_DATA.SysInfoProdIdentifier <system model> --host <imm_ip>
asu set SYSTEM_PROD_DATA.SysInfoSerialNum <s/n> --host <imm_ip>
asu set SYSTEM_PROD_DATA.SysEncloseAssetTag <asset_tag> --host <imm_ip>
```

- Bootable media:

You can also build a bootable media using the applications available through the Tools Center website at <http://www.ibm.com/support/entry/portal/docdisplay?lnocid=TOOL-CENTER>. From the left pane, click **IBM System x and BladeCenter Tools Center**, then click **Tool reference** for the available tools.

4. Restart the server.

Appendix. Getting help and technical assistance

If you need help, service, or technical assistance or just want more information about IBM products, you will find a wide variety of sources available from IBM to assist you.

Use this information to obtain additional information about IBM and IBM products, determine what to do if you experience a problem with your IBM system or optional device, and determine whom to call for service, if it is necessary.

Before you call

Before you call, make sure that you have taken these steps to try to solve the problem yourself.

If you believe that you require IBM to perform warranty service on your IBM product, the IBM service technicians will be able to assist you more efficiently if you prepare before you call.

- Check all cables to make sure that they are connected.
- Check the power switches to make sure that the system and any optional devices are turned on.
- Check for updated software, firmware, and operating-system device drivers for your IBM product. The IBM Warranty terms and conditions state that you, the owner of the IBM product, are responsible for maintaining and updating all software and firmware for the product (unless it is covered by an additional maintenance contract). Your IBM service technician will request that you upgrade your software and firmware if the problem has a documented solution within a software upgrade.
- If you have installed new hardware or software in your environment, check <http://www.ibm.com/systems/info/x86servers/serverproven/compat/us/> to make sure that the hardware and software is supported by your IBM product.
- Go to <http://www.ibm.com/supportportal/> to check for information to help you solve the problem.
- Gather the following information to provide to IBM Support. This data will help IBM Support quickly provide a solution to your problem and ensure that you receive the level of service for which you might have contracted.
 - Hardware and Software Maintenance agreement contract numbers, if applicable
 - Machine type number (IBM 4-digit machine identifier)
 - Model number
 - Serial number
 - Current system UEFI and firmware levels
 - Other pertinent information such as error messages and logs
- Go to http://www.ibm.com/support/entry/portal/Open_service_request/ to submit an Electronic Service Request. Submitting an Electronic Service Request will start the process of determining a solution to your problem by making the pertinent information available to IBM Support quickly and efficiently. IBM service technicians can start working on your solution as soon as you have completed and submitted an Electronic Service Request.

You can solve many problems without outside assistance by following the troubleshooting procedures that IBM provides in the online help or in the documentation that is provided with your IBM product. The documentation that comes with IBM systems also describes the diagnostic tests that you can perform. Most systems, operating systems, and programs come with documentation that contains troubleshooting procedures and explanations of error messages and error codes. If you suspect a software problem, see the documentation for the operating system or program.

Using the documentation

Information about your IBM system and preinstalled software, if any, or optional device is available in the documentation that comes with the product. That documentation can include printed documents, online documents, readme files, and help files.

See the troubleshooting information in your system documentation for instructions for using the diagnostic programs. The troubleshooting information or the diagnostic programs might tell you that you need additional or updated device drivers or other software. IBM maintains pages on the World Wide Web where you can get the latest technical information and download device drivers and updates. To access these pages, go to <http://www.ibm.com/supportportal/>.

Getting help and information from the World Wide Web

Up-to-date information about IBM products and support is available on the World Wide Web.

On the World Wide Web, up-to-date information about IBM systems, optional devices, services, and support is available at <http://www.ibm.com/supportportal/>. IBM System x information is at <http://www.ibm.com/systems/x/>. IBM BladeCenter information is at <http://www.ibm.com/systems/bladecenter/>. IBM IntelliStation information is at <http://www.ibm.com/systems/intellistation/>.

How to send DSA data to IBM

Use the IBM Enhanced Customer Data Repository to send diagnostic data to IBM.

Before you send diagnostic data to IBM, read the terms of use at <http://www.ibm.com/de/support/ecurep/terms.html>.

You can use any of the following methods to send diagnostic data to IBM:

- **Standard upload:** http://www.ibm.com/de/support/ecurep/send_http.html
- **Standard upload with the system serial number:** http://www.ecurep.ibm.com/app/upload_hw
- **Secure upload:** http://www.ibm.com/de/support/ecurep/send_http.html#secure
- **Secure upload with the system serial number:** https://www.ecurep.ibm.com/app/upload_hw

Creating a personalized support web page

You can create a personalized support web page by identifying IBM products that are of interest to you.

To create a personalized support web page, go to <http://www.ibm.com/support/mynotifications>. From this personalized page, you can subscribe to weekly email notifications about new technical documents, search for information and downloads, and access various administrative services.

Software service and support

Through IBM Support Line, you can get telephone assistance, for a fee, with usage, configuration, and software problems with your IBM products.

For more information about Support Line and other IBM services, see <http://www.ibm.com/services/> or see <http://www.ibm.com/planetwide/> for support telephone numbers. In the U.S. and Canada, call 1-800-IBM-SERV (1-800-426-7378).

Hardware service and support

You can receive hardware service through your IBM reseller or IBM Services.

To locate a reseller authorized by IBM to provide warranty service, go to <http://www.ibm.com/partnerworld/> and click **Business Partner Locator**. For IBM support telephone numbers, see <http://www.ibm.com/planetwide/>. In the U.S. and Canada, call 1-800-IBM-SERV (1-800-426-7378).

In the U.S. and Canada, hardware service and support is available 24 hours a day, 7 days a week. In the U.K., these services are available Monday through Friday, from 9 a.m. to 6 p.m.

IBM Taiwan product service

Use this information to contact IBM Taiwan product service.

台灣 IBM 產品服務聯絡方式：
台灣國際商業機器股份有限公司
台北市松仁路 7 號 3 樓
電話：0800-016-888

IBM Taiwan product service contact information:

IBM Taiwan Corporation
3F, No 7, Song Ren Rd.
Taipei, Taiwan
Telephone: 0800-016-888

Notices

This information was developed for products and services offered in the U.S.A.

IBM may not offer the products, services, or features discussed in this document in other countries. Consult your local IBM representative for information on the products and services currently available in your area. Any reference to an IBM product, program, or service is not intended to state or imply that only that IBM product, program, or service may be used. Any functionally equivalent product, program, or service that does not infringe any IBM intellectual property right may be used instead. However, it is the user's responsibility to evaluate and verify the operation of any non-IBM product, program, or service.

IBM may have patents or pending patent applications covering subject matter described in this document. The furnishing of this document does not give you any license to these patents. You can send license inquiries, in writing, to:

IBM Director of Licensing
IBM Corporation
North Castle Drive
Armonk, NY 10504-1785
U.S.A.

INTERNATIONAL BUSINESS MACHINES CORPORATION PROVIDES THIS PUBLICATION "AS IS" WITHOUT WARRANTY OF ANY KIND, EITHER EXPRESS OR IMPLIED, INCLUDING, BUT NOT LIMITED TO, THE IMPLIED WARRANTIES OF NON-INFRINGEMENT, MERCHANTABILITY OR FITNESS FOR A PARTICULAR PURPOSE. Some states do not allow disclaimer of express or implied warranties in certain transactions, therefore, this statement may not apply to you.

This information could include technical inaccuracies or typographical errors. Changes are periodically made to the information herein; these changes will be incorporated in new editions of the publication. IBM may make improvements and/or changes in the product(s) and/or the program(s) described in this publication at any time without notice.

Any references in this information to non-IBM websites are provided for convenience only and do not in any manner serve as an endorsement of those websites. The materials at those websites are not part of the materials for this IBM product, and use of those websites is at your own risk.

IBM may use or distribute any of the information you supply in any way it believes appropriate without incurring any obligation to you.

Trademarks

IBM, the IBM logo, and [ibm.com](http://www.ibm.com) are trademarks of International Business Machines Corp., registered in many jurisdictions worldwide. Other product and service names might be trademarks of IBM or other companies.

A current list of IBM trademarks is available on the web at <http://www.ibm.com/legal/us/en/copytrade.shtml>.

Adobe and PostScript are either registered trademarks or trademarks of Adobe Systems Incorporated in the United States and/or other countries.

Cell Broadband Engine is a trademark of Sony Computer Entertainment, Inc., in the United States, other countries, or both and is used under license therefrom.

Intel, Intel Xeon, Itanium, and Pentium are trademarks or registered trademarks of Intel Corporation or its subsidiaries in the United States and other countries.

Java and all Java-based trademarks and logos are trademarks or registered trademarks of Oracle and/or its affiliates.

Linux is a registered trademark of Linus Torvalds in the United States, other countries, or both.

Microsoft, Windows, and Windows NT are trademarks of Microsoft Corporation in the United States, other countries, or both.

UNIX is a registered trademark of The Open Group in the United States and other countries.

Important notes

Processor speed indicates the internal clock speed of the microprocessor; other factors also affect application performance.

CD or DVD drive speed is the variable read rate. Actual speeds vary and are often less than the possible maximum.

When referring to processor storage, real and virtual storage, or channel volume, KB stands for 1024 bytes, MB stands for 1,048,576 bytes, and GB stands for 1,073,741,824 bytes.

When referring to hard disk drive capacity or communications volume, MB stands for 1,000,000 bytes, and GB stands for 1,000,000,000 bytes. Total user-accessible capacity can vary depending on operating environments.

Maximum internal hard disk drive capacities assume the replacement of any standard hard disk drives and population of all hard disk drive bays with the largest currently supported drives that are available from IBM.

Maximum memory might require replacement of the standard memory with an optional memory module.

Each solid-state memory cell has an intrinsic, finite number of write cycles that the cell can incur. Therefore, a solid-state device has a maximum number of write cycles that it can be subjected to, expressed as total bytes written (TBW). A

device that has exceeded this limit might fail to respond to system-generated commands or might be incapable of being written to. IBM is not responsible for replacement of a device that has exceeded its maximum guaranteed number of program/erase cycles, as documented in the Official Published Specifications for the device.

IBM makes no representation or warranties regarding non-IBM products and services that are ServerProven[®], including but not limited to the implied warranties of merchantability and fitness for a particular purpose. These products are offered and warranted solely by third parties.

IBM makes no representations or warranties with respect to non-IBM products. Support (if any) for the non-IBM products is provided by the third party, not IBM.

Some software might differ from its retail version (if available) and might not include user manuals or all program functionality.

Particulate contamination

Attention: Airborne particulates (including metal flakes or particles) and reactive gases acting alone or in combination with other environmental factors such as humidity or temperature might pose a risk to the device that is described in this document.

Risks that are posed by the presence of excessive particulate levels or concentrations of harmful gases include damage that might cause the device to malfunction or cease functioning altogether. This specification sets forth limits for particulates and gases that are intended to avoid such damage. The limits must not be viewed or used as definitive limits, because numerous other factors, such as temperature or moisture content of the air, can influence the impact of particulates or environmental corrosives and gaseous contaminant transfer. In the absence of specific limits that are set forth in this document, you must implement practices that maintain particulate and gas levels that are consistent with the protection of human health and safety. If IBM determines that the levels of particulates or gases in your environment have caused damage to the device, IBM may condition provision of repair or replacement of devices or parts on implementation of appropriate remedial measures to mitigate such environmental contamination. Implementation of such remedial measures is a customer responsibility.

Table 23. Limits for particulates and gases

Contaminant	Limits
Particulate	<ul style="list-style-type: none"> The room air must be continuously filtered with 40% atmospheric dust spot efficiency (MERV 9) according to ASHRAE Standard 52.2¹. Air that enters a data center must be filtered to 99.97% efficiency or greater, using high-efficiency particulate air (HEPA) filters that meet MIL-STD-282. The deliquescent relative humidity of the particulate contamination must be more than 60%². The room must be free of conductive contamination such as zinc whiskers.
Gaseous	<ul style="list-style-type: none"> Copper: Class G1 as per ANSI/ISA 71.04-1985³ Silver: Corrosion rate of less than 300 Å in 30 days

Table 23. Limits for particulates and gases (continued)

Contaminant	Limits
	<p>¹ ASHRAE 52.2-2008 - <i>Method of Testing General Ventilation Air-Cleaning Devices for Removal Efficiency by Particle Size</i>. Atlanta: American Society of Heating, Refrigerating and Air-Conditioning Engineers, Inc.</p> <p>² The deliquescent relative humidity of particulate contamination is the relative humidity at which the dust absorbs enough water to become wet and promote ionic conduction.</p> <p>³ ANSI/ISA-71.04-1985. <i>Environmental conditions for process measurement and control systems: Airborne contaminants</i>. Instrument Society of America, Research Triangle Park, North Carolina, U.S.A.</p>

Documentation format

The publications for this product are in Adobe Portable Document Format (PDF) and should be compliant with accessibility standards. If you experience difficulties when you use the PDF files and want to request a web-based format or accessible PDF document for a publication, direct your mail to the following address:

*Information Development
IBM Corporation
205/A015
3039 E. Cornwallis Road
P.O. Box 12195
Research Triangle Park, North Carolina 27709-2195
U.S.A.*

In the request, be sure to include the publication part number and title.

When you send information to IBM, you grant IBM a nonexclusive right to use or distribute the information in any way it believes appropriate without incurring any obligation to you.

Telecommunication regulatory statement

This product may not be certified in your country for connection by any means whatsoever to interfaces of public telecommunications networks. Further certification may be required by law prior to making any such connection. Contact an IBM representative or reseller for any questions.

Electronic emission notices

When you attach a monitor to the equipment, you must use the designated monitor cable and any interference suppression devices that are supplied with the monitor.

Federal Communications Commission (FCC) statement

Note: This equipment has been tested and found to comply with the limits for a Class A digital device, pursuant to Part 15 of the FCC Rules. These limits are designed to provide reasonable protection against harmful interference when the equipment is operated in a commercial environment. This equipment generates, uses, and can radiate radio frequency energy and, if not installed and used in accordance with the instruction manual, may cause harmful interference to radio communications. Operation of this equipment in a residential area is likely to cause harmful interference, in which case the user will be required to correct the interference at his own expense.

Properly shielded and grounded cables and connectors must be used in order to meet FCC emission limits. IBM is not responsible for any radio or television interference caused by using other than recommended cables and connectors or by unauthorized changes or modifications to this equipment. Unauthorized changes or modifications could void the user's authority to operate the equipment.

This device complies with Part 15 of the FCC Rules. Operation is subject to the following two conditions: (1) this device may not cause harmful interference, and (2) this device must accept any interference received, including interference that might cause undesired operation.

Industry Canada Class A emission compliance statement

This Class A digital apparatus complies with Canadian ICES-003.

Avis de conformité à la réglementation d'Industrie Canada

Cet appareil numérique de la classe A est conforme à la norme NMB-003 du Canada.

Australia and New Zealand Class A statement

Attention: This is a Class A product. In a domestic environment this product may cause radio interference in which case the user may be required to take adequate measures.

European Union EMC Directive conformance statement

This product is in conformity with the protection requirements of EU Council Directive 2004/108/EC on the approximation of the laws of the Member States relating to electromagnetic compatibility. IBM cannot accept responsibility for any failure to satisfy the protection requirements resulting from a nonrecommended modification of the product, including the fitting of non-IBM option cards.

Attention: This is an EN 55022 Class A product. In a domestic environment this product may cause radio interference in which case the user may be required to take adequate measures.

Responsible manufacturer:

International Business Machines Corp.
New Orchard Road
Armonk, New York 10504
914-499-1900

European Community contact:

IBM Deutschland GmbH
Technical Regulations, Department M372
IBM-Allee 1, 71139 Ehningen, Germany
Telephone: +49 7032 15 2941
Email: lugi@de.ibm.com

Germany Class A statement

Deutschsprachiger EU Hinweis: Hinweis für Geräte der Klasse A EU-Richtlinie zur Elektromagnetischen Verträglichkeit

Dieses Produkt entspricht den Schutzanforderungen der EU-Richtlinie 2004/108/EG zur Angleichung der Rechtsvorschriften über die elektromagnetische Verträglichkeit in den EU-Mitgliedsstaaten und hält die Grenzwerte der EN 55022 Klasse A ein.

Um dieses sicherzustellen, sind die Geräte wie in den Handbüchern beschrieben zu installieren und zu betreiben. Des Weiteren dürfen auch nur von der IBM empfohlene Kabel angeschlossen werden. IBM übernimmt keine Verantwortung für die Einhaltung der Schutzanforderungen, wenn das Produkt ohne Zustimmung der IBM verändert bzw. wenn Erweiterungskomponenten von Fremdherstellern ohne Empfehlung der IBM gesteckt/eingebaut werden.

EN 55022 Klasse A Geräte müssen mit folgendem Warnhinweis versehen werden:
Warnung: Dieses ist eine Einrichtung der Klasse A. Diese Einrichtung kann im Wohnbereich Funk-Störungen verursachen; in diesem Fall kann vom Betreiber verlangt werden, angemessene Maßnahmen zu ergreifen und dafür aufzukommen.

Deutschland: Einhaltung des Gesetzes über die elektromagnetische Verträglichkeit von Geräten

Dieses Produkt entspricht dem Gesetz über die elektromagnetische Verträglichkeit von Geräten (EMVG). Dies ist die Umsetzung der EU-Richtlinie 2004/108/EG in der Bundesrepublik Deutschland.

Zulassungsbescheinigung laut dem Deutschen Gesetz über die elektromagnetische Verträglichkeit von Geräten (EMVG) (bzw. der EMC EG Richtlinie 2004/108/EG) für Geräte der Klasse A

Dieses Gerät ist berechtigt, in Übereinstimmung mit dem Deutschen EMVG das EG-Konformitätszeichen - CE - zu führen.

Verantwortlich für die Einhaltung der EMV Vorschriften ist der Hersteller:

International Business Machines Corp.
New Orchard Road
Armonk, New York 10504
914-499-1900

Der verantwortliche Ansprechpartner des Herstellers in der EU ist:

IBM Deutschland GmbH
Technical Regulations, Abteilung M372
IBM-Allee 1, 71139 Ehningen, Germany
Telephone: +49 7032 15 2941
Email: lugi@de.ibm.com

Generelle Informationen:

Das Gerät erfüllt die Schutzanforderungen nach EN 55024 und EN 55022 Klasse A.

Japan VCCI Class A statement

この装置は、クラス A 情報技術装置です。この装置を家庭環境で使用すると電波妨害を引き起こすことがあります。この場合には使用者が適切な対策を講ずるよう要求されることがあります。 VCCI-A

This is a Class A product based on the standard of the Voluntary Control Council for Interference (VCCI). If this equipment is used in a domestic environment, radio interference may occur, in which case the user may be required to take corrective actions.

Japan Electronics and Information Technology Industries Association (JEITA) statement

高調波ガイドライン準用品

Japan Electronics and Information Technology Industries Association (JEITA)
Confirmed Harmonics Guidelines with Modifications (products greater than 20 A per phase)

Korea Communications Commission (KCC) statement

이 기기는 업무용(A급)으로 전자파적합기기로서 판매자 또는 사용자는 이 점을 주의하시기 바라며, 가정외의 지역에서 사용하는 것을 목적으로 합니다.

This is electromagnetic wave compatibility equipment for business (Type A). Sellers and users need to pay attention to it. This is for any areas other than home.

Russia Electromagnetic Interference (EMI) Class A statement

ВНИМАНИЕ! Настоящее изделие относится к классу А. В жилых помещениях оно может создавать радиопомехи, для снижения которых необходимы дополнительные меры

People's Republic of China Class A electronic emission statement

声 明
此为 A 级产品。在生活环境中，该产品可能会造成无线电干扰。在这种情况下，可能需要用户对其干扰采取切实可行的措施。

Taiwan Class A compliance statement

警告使用者：
這是甲類的資訊產品，在居住的環境中使用時，可能會造成射頻干擾，在這種情況下，使用者會被要求採取某些適當的對策。

Index

A

- ABR, automatic boot failure recovery 327
- ac good LED 319
- ac power LED 14
- ac power supply 399, 401
- accessible documentation 490
- acoustical noise emissions 7
- adapter
 - PCI Express bus 381
 - PCI-X bus 381
 - remote battery
 - installing 413
 - removing 412
 - replacing 381
- adapter, installation 382
- administrator
 - password 466
- administrator password 461
- ASM event log 27, 28
- assertion event, system-event log 27
- assistance, getting 483
- attention notices 6
- Australia Class A statement 491
- automatic boot failure recovery (ABR) 327

B

- backplane assembly, hot-swap SAS/SATA
 - removing 431
- backplane, hot-swap SAS/SATA
 - removing 429
- baseboard management controller 17
- battery, replacing 417
- battery, system
 - installing 417
 - replacing 415
- bays 7
- before you install a legacy operating system 459
- bezel
 - installing 419
 - removing 418
- blue-screen capture feature
 - overview 468
- Boot Manager program 456, 466
- Broadcom Gigabit Ethernet Utility program
 - enabling 471
- button, presence detection 11

C

- cabling
 - internal routing 350
- Canada Class A electronic emission statement 491
- caution statements 6

- CDs
 - recovery 339
- checkout procedure 290
 - performing 291
- checkpoint codes 26
- checkpoint codes display
 - light path diagnostics panel display 309
- China Class A electronic emission statement 494
- Class A electronic emission notice 491
- collecting data 1
- components
 - server 333
- configuration
 - information 455
 - instructions 455
 - Nx boot failure 327
 - ServerGuide Setup and Installation CD 455
 - Setup utility 455
- configuration programs
 - LSI Configuration Utility 456
- configuring
 - with ServerGuide 459
- configuring hardware 456
- configuring your server 455
- connector
 - Ethernet 14
 - Ethernet systems-management 14
 - power supply 14
 - serial 14
 - USB 10, 14
 - video
 - front 10
 - rear 14
- connectors
 - external 19
 - internal 18
 - internal cable routing 350
 - option 23
 - rear 14
- consumable parts 339
- contamination, particulate and gaseous 7, 489
- controllers
 - Ethernet 472
- controls and LEDs
 - on the light path diagnostics panel 12
 - on the operator information panel 11
- cover
 - installing 357
 - removing 356
- creating
 - RAID array 474
- creating a personalized support web page 485
- CRUs, replacing
 - adapter 381
 - cover 357

- CRUs, replacing (*continued*)
 - DIMMs 362
 - DVD drive 375
 - memory 362
 - system battery 415
- custom support web page 485
- customer replaceable units (CRUs) 333

D

- danger statements 6
- data collection 1
- dc good LED 319
- dc power LED 14
- dc power supply LED errors 321
- deassertion event, system-event log 27
- devices, static-sensitive
 - handling 350
- diagnostic
 - error codes 26, 257
 - event logs 26
 - on-board programs, starting 255
 - POST error codes and event log 26
 - programs, overview 255
 - test log, viewing 257
 - text message format 256
 - tools, overview 26
- diagnostics 25
- dimension 7
- DIMM
 - installing 369
- DIMM air baffle
 - installing 361
 - removing 360
- DIMM installation sequence
 - memory mirroring 366, 368
- DIMMs
 - installing 363
 - order of installation for non-mirroring mode 366
 - removing 362
- display area
 - light path diagnostics panel 309
- display problems 300
- documentation 5
 - format 490
 - updates 5
 - using 484
- documentation, updated
 - finding 5
- drive, DVD
 - installing 423
 - removing 422
- DSA log 27, 28
- DSA, sending data to IBM 484
- DVD
 - drive activity LED 10
 - eject button 10
- DVD drive
 - installing 377, 423
 - problems 292

DVD drive (*continued*)
removing 422
replacing 375
DVD drive, installing 377

E

electrical equipment, servicing x
electrical input 7
electronic emission Class A notice 491
embedded hypervisor
using 470
enabling 469
enclosure management heartbeat
LED 322
environment 7
error codes and messages
diagnostic 257
IMM 30
messages, diagnostic 255
POST 242
error logs
clearing 29
viewing 28
error messages 30
error symptoms
DVD drive 292
general 293
hard disk drive 294
hypervisor flash device 295
intermittent 296
keyboard, non-USB 297
memory 298
microprocessor 300
monitor 300
mouse, non-USB 297
optional devices 303
pointing device, non-USB 297
power 304
serial port 307
ServerGuide 307
software 308
USB port 309
video 309
errors
dc power supply LEDs 321
format, diagnostic code 256
Ethernet
controller
troubleshooting 328
link status LED 14
systems-management connector 14
Ethernet activity
LED 11, 14
Ethernet connector 14
Ethernet controller configuration 456
European Union EMC Directive
conformance statement 492
event logs 27
event logs, methods for viewing 28
event lot, POST 27
event lot, system 27
expansion bays 7

F

fan
replacing 396, 398
FCC Class A notice 491
features 7
ServerGuide 458
field replaceable units (FRUs) 333
finding
updated documentation 5
firmware
updates 5
firmware updates 5, 347
firmware, server
starting 466
firmware, server, recovering 323
firmware, server, updating 441
firmware, updating 455
formatting
hard disk drive 474

G

gaseous contamination 7, 489
general
problems 293
Germany Class A statement 492
grease, thermal 446
guidelines
options installation 347
servicing electrical equipment x
system reliability 349
trained service technicians ix

H

handling static-sensitive devices 350
hard disk drive
formatting 474
hot-swap SATA 370
installing 371
problems 294
removing 370
SAS 370
SCSI 370
simple-swap SATA 372
hard disk drive (SATA), installing
(simple-swap 2.5-inch) 373
hard disk drive activity LED 10
hard disk drive status LED 10
hard disk drive, installing (hot-swap
2.5-inch) 371
hard drive activity
LED 11
hardware service and support telephone
numbers 485
hardware, configuring 456
heat output 7
heat sink
installing 441
removing 439
heat sink retention module
installing 448
removing 447
help
from the World Wide Web 484
from World Wide Web 484

help (*continued*)
sending diagnostic data to IBM 484
sources of 483
hot-swap
fans, replacing 396, 398
hot-swap ac power supply 399, 401
installing 401
removing 399
hot-swap disk drive, installing
2.5-inch 371
hot-swap drive
SAS/SATA IDs 372
hot-swap SAS/SATA backplane
installing 430
replacing 429
humidity 7
hypervisor flash device
installing 405
problems 295

I

IBM Advanced Settings Utility program
overview 475
IBM Systems Director
updating 475
IBM Taiwan product service 485
IDs for SAS/SATA hot-swap drives 372
IDs for SATA simple-swap drives 375
IMM 456, 467
error messages 30
IMM heartbeat
LED 322
IMM web interface 470
important notices 6, 488
IN OK LED 321
IN OK power LED 14
information center 484
inspecting for unsafe conditions ix
installation guidelines 347
installing
2.5-inch hot-swap hard disk
drive 371
2.5-inch simple-swap SATA hard disk
drive 373
battery, system 417
bezel 419
cover 357
DIMM 369
DIMM air baffle 361
DIMMs 363
DVD cable 423
DVD drive 377
hard disk drive 371
heat sink 441
heat sink retention module 448
hot-swap ac power supply 401
hot-swap fan 398
hot-swap SAS/SATA backplane 430
hypervisor flash device 405
microprocessor 441
microprocessor 2 air baffle 359
operator information panel 434
optical drive bay 421
PCI riser card bracket 428
PCI riser-card assembly 426
RAID adapter remote battery 413

- installing (*continued*)
 - safety cover 438
 - ServeRAID adapter advanced feature key 394
 - simple-swap SATA backplate assembly 432
 - system board 451
 - two-port Ethernet adapter 409
 - virtual media key 407
- integrated functions 7
- integrated management module
 - error messages 30
 - event log 27, 28
 - LED 322
 - using 467
- Integrated Management Module programs 456
- intermittent problems 296
- internal cable routing 350
- internal connectors 18
- introduction 5
- IP address
 - obtaining for the IMM 469
- IPMI event log 27, 28
- IPMItool 28

J

- Japan Class A electronic emission statement 493
- Japan Electronics and Information Technology Industries Association statement 494
- JEITA statement 494
- jumper
 - UEFI boot recovery 324

K

- key, virtual media
 - installing 407
- keyboard problems 297
- Korea Class A electronic emission statement 494

L

- LED
 - ac power 14
 - dc power 14
 - DVD drive activity 10
 - enclosure management heartbeat 322
 - Ethernet activity 11
 - Ethernet-link status 14
 - for Ethernet activity 14
 - hard disk drive activity 10
 - hard disk drive status 10
 - hard drive activity 11
 - IMM heartbeat 322
 - IN OK power 14
 - integrated management module 322
 - location 10
 - OUT OK power 14
 - power supply error
 - rear 14

- LED (*continued*)
 - power-on 11
 - rear 14
 - system information 11
 - system locator 11
 - system-error 11
 - rear 14
 - system-locator
 - rear 14
- LED errors
 - dc power supply 321
- LEDs
 - power-supply 319
- LEDs, system pulse 322
- legacy operating system
 - requirement 459
- License Agreement for Machine Code 5
- Licenses and Attributions Documents 5
- light panel diagnostics panel
 - location 10
- light path diagnostics 309
 - LEDs 312
 - panel 309
- light path diagnostics LEDs 312
- light path diagnostics panel
 - checkpoint code display 309
 - controls and LEDs 12
 - NMI button 12, 309
- light path diagnostics panel display
 - checkpoint codes 309
- log on 470
- LSI Configuration Utility program
 - starting 473
 - using 472

M

- memory
 - removing 362
 - specifications 7
 - two-DIMM-per-channel (2DPC) 363
- memory installation sequence
 - non-mirroring mode 366
- memory mirroring
 - description 366
 - DIMM population sequence 366, 368
- memory online-spare
 - description 368
- memory problems 298
- menu choices
 - Setup utility 461
- messages
 - diagnostic 255
- messages, error
 - POST 242
- method 327
- methods, for viewing event logs 28
- microprocessor
 - installing 441
 - problems 300
 - removing 439
 - specifications 7
- microprocessor 2 air baffle
 - installing 359
 - removing 358
- mirroring mode 366

- model and serial number
 - location 330
- monitor problems 300

N

- New Zealand Class A statement 491
- NMI button
 - light path diagnostics panel 309
 - on the light path diagnostics panel 12
- NOS installation
 - ServerGuide 459
 - without ServerGuide 460
- notes 6
- notes, important 488
- notices 487
 - electronic emission 491
 - FCC, Class A 491
- notices and statements 6
- Nx boot failure 327

O

- obtaining
 - IP address for IMM 469
- online documentation 5
- online publications 5
- online-spare mode 368
- operating-system event log 27, 28
- operator information panel
 - controls and LEDs 11
 - installing 434
 - removing 433
- operator information panel release latch 10
- optical drive bay
 - installing 421
 - removing 420
- optional device problems 303
- optional optical drive
 - specifications 7
- OUT OK LED 321
- OUT OK power LED 14
- out-of-band 327

P

- particulate contamination 7, 489
- parts listing 333
- parts, consumable 339
- password 464
 - administrator 464
 - power-on 464
- password, power-on
 - switch on system board 464
- PCI
 - riser card bracket 427
 - riser-card assembly 425, 426
 - slot 1 14
 - slot 2 14
- PCI expansion slots 7
- PCI riser card bracket
 - installing 428
- PCI riser slots
 - installation configurations 382

- PCI riser slots *(continued)*
 - supported configurations 382
- PCI riser-card assembly
 - installing 426
 - removing 425
- People's Republic of China Class A electronic emission statement 494
- POST 242
 - error codes 242
 - error log 28
- POST event log 27
- power
 - power-control button 11
 - power-on LED 16
 - server 16
 - specifications 7
 - supply 7
- power cords 344
- power on and working inside the server 349
- power problems 304, 328
- power supply
 - ac 399, 401
 - installing 401
 - removing 399
- power-on LED
 - rear 14
- power-on LED 11
- power-on password 461
- power-supply LEDs 319
- power-supply LEDs 319
 - AC 319
- presence detection button 11
- problem isolation tables 292
- problems
 - DVD drive 292
 - Ethernet controller 328
 - general 293
 - hard disk drive 294
 - hypervisor flash device 295
 - IMM 30
 - intermittent 296
 - memory 298
 - microprocessor 300
 - monitor 300
 - mouse 297
 - optional devices 303
 - pointing device 297
 - power 304, 328
 - serial port 307
 - software 308
 - undetermined 329
 - USB port 309
 - video 300, 309
- procedure, checkout 291
- product service, IBM Taiwan 485
- publications
 - online 5
 - product data 5

R

- rack release latches 10
- RAID
 - riser-card assembly 385, 386

- RAID array
 - creating 474
- RAID controller
 - removing 387, 389
- rear view 14
- recovering the server firmware 323
- recovery CDs 339
- redundant array of independent disks (RAID)
 - adapter 371
- remind button 12, 309
- remote battery, RAID adapter
 - installing 413
 - removing 412
- remote presence feature 469
 - using 468
- Remote presence support 456
- removing
 - adapter 381
 - battery, system 415
 - bezel 418
 - components 347
 - DIMM 362
 - DIMM air baffle 360
 - DVD cable 422
 - DVD drive 375
 - hard disk drive 370
 - heat sink 439
 - heat sink retention module 447
 - hot-swap ac power supply 399
 - hot-swap fan 396
 - hot-swap SAS/SATA backplane 429
 - hypervisor 404
 - microprocessor 439
 - microprocessor 2 air baffle 358
 - operator information panel 433
 - optical drive bay 420
 - PCI riser card bracket 427
 - PCI riser-card assembly 425
 - RAID adapter remote battery 412
 - RAID controller 387, 389
 - safety cover 437
 - SAS/SATA controller 387, 389
 - ServeRAID adapter advanced feature key 392
 - simple-swap SATA backplate assembly 431
 - system board 449
 - two-port Ethernet adapter 408
 - virtual media key 406
- replacement parts 333
- replacing
 - battery, system 415, 417
 - components 347
 - consumable parts 355
 - DVD drive 375
 - SAS/SATA backplane 429
 - the SATA backplate assembly 431
 - Tier 1 CRUs 355
- reset button 12, 309
- retention module, heat sink
 - installing 448
 - removing 447
- returning
 - component 350
 - device 350

- riser card
 - connector location 18
- riser-card assembly
 - location 381
- Russia Class A electronic emission statement 494

S

- safety vii
- safety cover
 - installing 438
 - removing 437
- Safety Information 6
- safety statements vii, xi
- SAS/SATA
 - IDs for hot-swap drives 372
- SAS/SATA controller
 - hypervisor 404
 - removing 387, 389
- SATA
 - IDs for simple-swap drives 375
- sending diagnostic data to IBM 484
- serial and model number
 - location 330
- serial connector 14
- serial number 5
- serial port problems 307
- server
 - working inside with the power on 349
- Server
 - power features 16
 - server components 333
 - server firmware
 - updating 441
 - server firmware, recovering 323
 - server replaceable units 333
 - server, backup firmware
 - starting 466
- ServeRAID adapter
 - removing 387, 389
- ServeRAID adapter advanced feature key
 - hypervisor 392
 - installing 394
- ServerGuide
 - features 458
 - NOS installation 459
 - setup 459
 - Setup and Installation CD 455
 - using 458
- ServerGuide CD 5
- service and support
 - before you call 483
 - hardware 485
 - software 485
- servicing electrical equipment x
- Setup utility 455, 456, 460
 - menu choices 461
 - starting 460
 - using 460
- shutdown 17
- simple-swap drive
 - SATA IDs 375
- simple-swap front view
 - LED location 10

- simple-swap SATA backplate assembly
 - installing 432
 - replacing 431
- simple-swap SATA disk drive (2.5-inch), installing 373
- simple-swap, SATA hard disk drive removing 372
- size 7
- slots
 - PCI expansion 7
- software problems 308
- software service and support telephone numbers 485
- specifications 7
- standby mode 16
- starting
 - LSI Configuration Utility program 473
 - server firmware 466
 - Setup utility 460
- statements and notices 6
- static-sensitive devices handling 350
- support web page, custom 485
- SW3 switch block description 19
- SW4 switch block description 19
- switch block
 - system board 19
- switches and jumpers
 - system board 19
- system
 - error LED front 11
 - locator LED front 11
 - system-error LED rear 14
- System
 - information LED 11
- system board
 - installing 451
 - internal connectors 18
 - power-on password switch 464
 - removing 449
 - switches and jumpers 19
- system event log 30
- system event logs 28
- system pulse LEDs 322
- system reliability guidelines 349
- system-board LEDs 22
- system-event log 27
- system-event log, assertion event 27
- system-event log, deassertion event 27
- system-locator LED
 - rear 14
- systems-management
 - Ethernet connector 14

T

- Taiwan Class A electronic emission statement 495
- telecommunication regulatory statement 490
- telephone numbers 485
- temperature 7
- test log, viewing 257
- thermal grease 446

- TOE 7
- tools, diagnostic 26
- trademarks 488
- trained service technicians, guidelines ix
- turning off the server 17
 - baseboard management controller 17
- turning on the server 16
- two-DIMM-per-channel (2DPC) requirements 363

U

- UEFI
 - boot recovery jumper 324
- undetermined problems 329
- undocumented problems 3
- United States FCC Class A notice 491
- Universal Serial Bus (USB) problems 309
- unsafe conditions, inspecting for ix
- UpdateXpress 455
- updating
 - DMI/SMBIOS data 479
 - IBM Systems Director 475
 - server firmware 441
 - Systems Director, IBM 475
 - Universal Unique Identifier (UUID) 477
- updating firmware 455
- USB
 - connector 10, 14
- using
 - embedded hypervisor 470
 - IMM 467
 - integrated management module 467
 - LSI Configuration Utility program 472
 - remote presence feature 468
 - Setup utility 460
- utility
 - Setup 460
- Utility program
 - IBM Advanced Settings 475
- utility, Setup 456

V

- video connector
 - front 10
 - rear 14
- video controller, integrated specifications 7
- video problems 300
- viewing event logs 28
- virtual media key installing 407
- VMware Hypervisor support 456

W

- Wake on LAN feature 16
- website
 - UEFI flash diskette 323
- weight 7
- working inside the server
 - power on 349



Part Number: 00KC033

Printed in USA

(1P) P/N: 00KC033

