

IBM System x3755 M3 Type 7164



Installation and User's Guide

IBM System x3755 M3 Type 7164



Installation and User's Guide

Note: Before using this information and the product it supports, read the general information in Appendix B, "Notices," on page 95, the *IBM Safety Information* and *Environmental Notices and User Guide* documents on the *IBM Documentation CD*, and the *Warranty Information*.

The most recent version of this document is available at <http://www.ibm.com/systems/support/>.

Sixth Edition (December 2012)

© Copyright IBM Corporation 2012.

US Government Users Restricted Rights – Use, duplication or disclosure restricted by GSA ADP Schedule Contract with IBM Corp.

Contents

Safety	vii
Chapter 1. The System x3755 M3 server	1
The IBM Documentation CD	2
Hardware and software requirements	2
Using the Documentation Browser	2
Related documentation	3
Notices and statements in this document	4
Features and specifications	4
What your server offers	8
Reliability, availability, and serviceability	11
IBM Systems Director	12
The UpdateXpress System Pack Installer (UXSPI)	12
Server controls, LEDs, and power	12
Front view	13
Rear view	16
Rear view LEDs	17
Server power features	18
Chapter 2. Installing optional devices.	21
Instructions for IBM Business Partners	21
How to send DSA data to IBM	22
Server components	23
System-board internal connectors	24
System-board DIMM connectors	25
System-board external connectors	26
System-board jumpers	27
System-board LEDs	29
PCI riser-card adapter connectors	30
Installation guidelines	30
A single-power-supply server operating at 100 V or 240 V ac	31
System reliability guidelines	31
Handling static-sensitive devices	32
Internal cable routing and connectors	33
Hot-swap hard disk drive backplane cable connections	33
Simple-swap hard disk drive backplate cable connections	34
DVD drive cable connection	36
Front USB assembly cable connection	37
Power-supply distribution board cable connections	38
Removing the top cover	39
Removing the top-cover fan door	39
Removing the PCI riser-card assembly	40
Removing the air baffle	41
Installing a PCI adapter	42
Installing a ServeRAID SAS/SATA controller	45
Installing a ServeRAID controller battery on the remote battery tray	47
Installing an optional ServeRAID controller advanced feature key	52
Installing a hot-swap power supply	53
Installing a hot-swap hard disk drive	55
Installing a simple-swap hard disk drive	56
Installing an optional DVD drive	58
Installing an optional tape drive enablement kit and tape drive	59
Installing an internal flash memory	61

Memory modules (DIMMs)	63
Installing a memory module	65
Installing a microprocessor	66
Thermal grease.	69
Completing the installation.	70
Installing the PCI riser-card assembly	70
Installing the air baffle	71
Installing the top cover	73
Installing the top-cover fan door.	73
Connecting the cables	74
Updating the server configuration	74
Chapter 3. Configuring the server	77
Using the Setup utility	78
Starting the Setup utility	78
Setup utility menu choices.	78
Passwords	81
Using the Boot Selection Menu program	82
Starting the backup server firmware	82
Using the ServerGuide Setup and Installation CD	83
ServerGuide features	83
Setup and configuration overview	84
Typical operating-system installation	84
Installing your operating system without using ServerGuide	85
Using the integrated baseboard management controller	85
Obtaining the IP address for web interface access	86
Logging on to the web interface.	86
Using the remote presence and blue-screen capture features.	87
Enabling the Broadcom Gigabit Ethernet Utility program.	87
Configuring the Broadcom Gigabit Ethernet controller.	87
Configuring RAID arrays	88
Using the IBM Advanced Settings Utility program	88
Updating IBM Systems Director.	88
Appendix A. Getting help and technical assistance	91
Before you call	91
Using the documentation	92
Getting help and information from the World Wide Web	92
How to send Dynamic System Analysis data to IBM	92
Creating a personalized support web page.	92
Software service and support	92
Hardware service and support	93
IBM Taiwan product service	93
Appendix B. Notices	95
Trademarks	95
Important notes.	96
Battery return program	97
German Ordinance for Work gloss statement.	98
Particulate contamination	99
Documentation format	99
Telecommunication regulatory statement	100
Electronic emission notices	100
Federal Communications Commission (FCC) statement	100
Industry Canada Class A emission compliance statement.	100
Avis de conformité à la réglementation d'Industrie Canada	100

Australia and New Zealand Class A statement	100
European Union EMC Directive conformance statement	101
Germany Class A statement	101
VCCI Class A statement	102
Japan Electronics and Information Technology Industries Association (JEITA) statement	102
Korea Communications Commission (KCC) statement	102
Russia Electromagnetic Interference (EMI) Class A statement	103
People's Republic of China Class A electronic emission statement	103
Taiwan Class A compliance statement	103
Index	105

Safety

Before installing this product, read the Safety Information.

قبل تركيب هذا المنتج، يجب قراءة الملاحظات الأمنية

Antes de instalar este produto, leia as Informações de Segurança.

在安装本产品之前，请仔细阅读 **Safety Information** (安全信息)。

安裝本產品之前，請先閱讀「安全資訊」。

Prije instalacije ovog produkta obavezno pročitajte Sigurnosne Upute.

Před instalací tohoto produktu si přečtěte příručku bezpečnostních instrukcí.

Læs sikkerhedsforskrifterne, før du installerer dette produkt.

Lees voordat u dit product installeert eerst de veiligheidsvoorschriften.

Ennen kuin asennat tämän tuotteen, lue turvaohjeet kohdasta Safety Information.

Avant d'installer ce produit, lisez les consignes de sécurité.

Vor der Installation dieses Produkts die Sicherheitshinweise lesen.

Πριν εγκαταστήσετε το προϊόν αυτό, διαβάστε τις πληροφορίες ασφάλειας (safety information).

לפני שתתקינו מוצר זה, קראו את הוראות הבטיחות.

A termék telepítése előtt olvassa el a Biztonsági előírásokat!

Prima di installare questo prodotto, leggere le Informazioni sulla Sicurezza.

製品の設置の前に、安全情報をお読みください。

본 제품을 설치하기 전에 안전 정보를 읽으십시오.

Пред да се инсталира овој продукт, прочитајте информацијата за безбедност.

Les sikkerhetsinformasjonen (Safety Information) før du installerer dette produktet.

Przed zainstalowaniem tego produktu, należy zapoznać się z książką "Informacje dotyczące bezpieczeństwa" (Safety Information).

Antes de instalar este produto, leia as Informações sobre Segurança.

Перед установкой продукта прочтите инструкции по технике безопасности.

Pred inštaláciou tohto zariadenia si pečítajte Bezpečnostné predpisy.

Pred namestitvijo tega proizvoda preberite Varnostne informacije.

Antes de instalar este producto, lea la información de seguridad.

Läs säkerhetsinformationen innan du installerar den här produkten.

Bu ürünü kurmadan önce güvenlik bilgilerini okuyun.

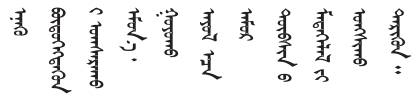

ཐོན་རྒྱུ་འདི་བདེ་སྤྱོད་མ་བྱས་གོང་། རྒྱ་རྒྱུ་ཡིད་གཟབ་
བྱ་འདྲ་མིན་ཡོད་པའི་འོད་སྤེར་བལྟ་དགོས།

مەزكۇر مەھسۇلاتنى ئورنىتىشتىن بۇرۇن بىخەتەرلىك ئۇچۇرلىرىنى ئوقۇپ چىقىڭ.

Youq mwngz yungh canjbinj neix gaxgonq, itdingh aeu doeg aen
canjbinj soengq cungj vahgangj ancien siusik.

Important:

Each caution and danger statement in this document is labeled with a number. This number is used to cross reference an English-language caution or danger statement with translated versions of the caution or danger statement in the *Safety Information* document.

For example, if a caution statement is labeled “Statement 1,” translations for that caution statement are in the *Safety Information* document under “Statement 1.”

Be sure to read all caution and danger statements in this document before you perform the procedures. Read any additional safety information that comes with the server or optional device before you install the device.

Statement 1:



DANGER

Electrical current from power, telephone, and communication cables is hazardous.

To avoid a shock hazard:

- **Do not connect or disconnect any cables or perform installation, maintenance, or reconfiguration of this product during an electrical storm.**
- **Connect all power cords to a properly wired and grounded electrical outlet.**
- **Connect to properly wired outlets any equipment that will be attached to this product.**
- **When possible, use one hand only to connect or disconnect signal cables.**
- **Never turn on any equipment when there is evidence of fire, water, or structural damage.**
- **Disconnect the attached power cords, telecommunications systems, networks, and modems before you open the device covers, unless instructed otherwise in the installation and configuration procedures.**
- **Connect and disconnect cables as described in the following table when installing, moving, or opening covers on this product or attached devices.**

To Connect:

1. Turn everything OFF.
2. First, attach all cables to devices.
3. Attach signal cables to connectors.
4. Attach power cords to outlet.
5. Turn device ON.

To Disconnect:

1. Turn everything OFF.
2. First, remove power cords from outlet.
3. Remove signal cables from connectors.
4. Remove all cables from devices.

Statement 2:



CAUTION:

When replacing the lithium battery, use only IBM Part Number 33F8354 or an equivalent type battery recommended by the manufacturer. If your system has a module containing a lithium battery, replace it only with the same module type made by the same manufacturer. The battery contains lithium and can explode if not properly used, handled, or disposed of.

Do not:

- **Throw or immerse into water**
- **Heat to more than 100°C (212°F)**
- **Repair or disassemble**

Dispose of the battery as required by local ordinances or regulations.

Statement 3:



CAUTION:

When laser products (such as CD-ROMs, DVD drives, fiber optic devices, or transmitters) are installed, note the following:

- Do not remove the covers. Removing the covers of the laser product could result in exposure to hazardous laser radiation. There are no serviceable parts inside the device.
- Use of controls or adjustments or performance of procedures other than those specified herein might result in hazardous radiation exposure.



DANGER

Some laser products contain an embedded Class 3A or Class 3B laser diode. Note the following.

Laser radiation when open. Do not stare into the beam, do not view directly with optical instruments, and avoid direct exposure to the beam.



Class 1 Laser Product
Laser Klasse 1
Laser Klass 1
Luokan 1 Laserlaite
Appareil À Laser de Classe 1

Statement 4:

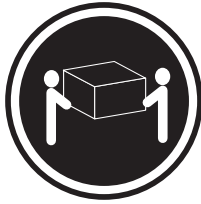

≥ 18 kg (39.7 lb)



≥ 32 kg (70.5 lb)

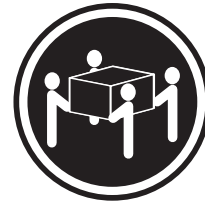

≥ 55 kg (121.2 lb)

CAUTION:

Use safe practices when lifting.

Statement 5:



CAUTION:

The power control button on the device and the power switch on the power supply do not turn off the electrical current supplied to the device. The device also might have more than one power cord. To remove all electrical current from the device, ensure that all power cords are disconnected from the power source.

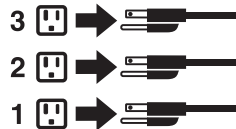

Statement 8:



CAUTION:

Never remove the cover on a power supply or any part that has the following label attached.



Hazardous voltage, current, and energy levels are present inside any component that has this label attached. There are no serviceable parts inside these components. If you suspect a problem with one of these parts, contact a service technician.

Statement 11:



CAUTION:

The following label indicates sharp edges, corners, or joints nearby.



Statement 12:



CAUTION:

The following label indicates a hot surface nearby.



Statement 13:



DANGER

Overloading a branch circuit is potentially a fire hazard and a shock hazard under certain conditions. To avoid these hazards, ensure that your system electrical requirements do not exceed branch circuit protection requirements. Refer to the information that is provided with your device for electrical specifications.

Statement 15:



CAUTION:

Make sure that the rack is secured properly to avoid tipping when the server unit is extended.

Statement 17:



CAUTION:

The following label indicates moving parts nearby.



Statement 26:



CAUTION:

Do not place any object on top of rack-mounted devices.



Attention: This product is suitable for use on an IT power distribution system whose maximum phase to phase voltage is 240 V under any distribution fault condition.

Important: This product is not suitable for use with visual display workplace devices according to Clause 2 of the German Ordinance for Work with Visual Display Units.

Statement 35:



CAUTION:

Hazardous energy present. Voltages with hazardous energy might cause heating when shorted with metal, which might result in splattered metal, burns, or both.

Attention: This server is suitable for use on an IT power distribution system whose maximum phase-to-phase voltage is 240 V under any distribution fault condition.

Important: Maschinenlärminformations-Verordnung - 3. GPSGV, der höchste Schalldruckpegel beträgt 70 dB(A) oder weniger.

United Kingdom - Notice to Customers:

This apparatus is approved under approval number NS/G/1234/J/100003 for indirect connection to public telecommunication systems in the United Kingdom.

Chapter 1. The System x3755 M3 server

This *Installation and User's Guide* contains instructions for setting up your IBM System x3755 M3 Type 7164 server, installing optional devices, and for starting and configuring the server. For diagnostic and troubleshooting information and instructions for removing and installing server components, see the *Problem Determination and Service Guide* that is on the IBM *Documentation CD*.

In addition to the instructions in Chapter 2, "Installing optional devices," on page 21 for installing optional hardware devices, updating firmware and device drivers, and completing the installation, IBM Business Partners must also complete the steps in "Instructions for IBM Business Partners" on page 21.

The IBM System x3755 M3 server is a 2U¹-high, high-performance server. It is ideally suited for networking environments that require superior microprocessor performance, efficient memory management, flexibility, and large amounts of reliable data storage.

Performance, ease of use, reliability, and expansion capabilities were key considerations in the design of the server. These design features make it possible for you to customize the system hardware to meet your needs today and provide flexible expansion capabilities for the future.

The server comes with a limited warranty. For information about the terms of the warranty and getting service and assistance, see the *Warranty Information* document that comes with the server.

The server contains IBM Enterprise X-Architecture technologies, which help increase performance, reliability, and availability. For more information, see "What your server offers" on page 8 and "Reliability, availability, and serviceability" on page 11.

You can obtain up-to-date information about the server and other IBM® server products at <http://www.ibm.com/systems/x/>. At <http://www.ibm.com/support/mysupport/>, you can create a personalized support page by identifying IBM products that are of interest to you. From this personalized page, you can subscribe to weekly email notifications about new technical documents, search for information and downloads, and access various administrative services.

If you participate in the IBM client reference program, you can share information about your use of technology, best practices, and innovative solutions; build a professional network; and gain visibility for your business. For more information about the IBM client reference program, see <http://www.ibm.com/ibm/clientreference/>.

If firmware and documentation updates are available, you can download them from the IBM website. The server might have features that are not described in the documentation that comes with the server, and the documentation might be updated occasionally to include information about those features, or technical updates might be available to provide additional information that is not included in the server documentation. To check for updates, go to <http://www.ibm.com/supportportal/>.

1. Racks are measured in vertical increments of 4.45 cm (1.75 inches) each. Each increment is called a "U." A 1-U-high device is 1.75 inches tall.

Record information about the server in the following table.

Product name	IBM System x3755 M3
Machine type	7164
Model number	_____
Serial number	_____

The model number and serial number are on labels on the bottom of the server and on the front bezel, as shown in the following illustration.

Note: The illustrations in this document might differ slightly from your server.

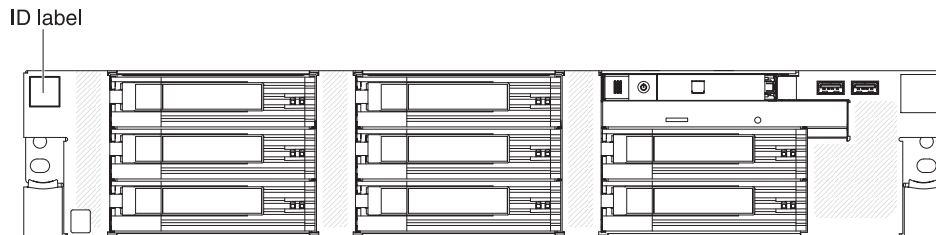

For a list of supported optional devices for the server, see <http://www.ibm.com/systems/info/x86servers/serverproven/compat/us/>.

The IBM Documentation CD

The IBM *Documentation* CD contains documentation for your server in Portable Document Format (PDF) and includes the IBM Documentation Browser to help you find information quickly.

Hardware and software requirements

The IBM *Documentation* CD requires the following minimum hardware and software:

- Microsoft Windows XP, Windows 2000, or Red Hat Linux
- 100 MHz microprocessor
- 32 MB of RAM
- Adobe Acrobat Reader 3.0 (or later) or xpdf, which comes with Linux operating systems

Using the Documentation Browser

Use the Documentation Browser to browse the contents of the CD, read brief descriptions of the documents, and view documents, using Adobe Acrobat Reader or xpdf. The Documentation Browser automatically detects the regional settings in your server and displays the documents in the language for that region (if available). If a document is not available in the language for that region, the English-language version is displayed.

Use one of the following procedures to start the Documentation Browser:

- If Autostart is enabled, insert the CD into the CD or DVD drive. The Documentation Browser starts automatically.
- If Autostart is disabled or is not enabled for all users, use one of the following procedures:

- If you are using a Windows operating system, insert the CD into the CD or DVD drive and click **Start --> Run**. In the **Open** field, type

```
e:\win32.bat
```

where *e* is the drive letter of the CD or DVD drive, and click **OK**.

- If you are using Red Hat Linux, insert the CD into the CD or DVD drive; then, run the following command from the /mnt/cdrom directory:

```
sh runlinux.sh
```

Select your server from the **Product** menu. The **Available Topics** list displays all the documents for your server. Some documents might be in folders. A plus sign (+) indicates each folder or document that has additional documents under it. Click the plus sign to display the additional documents.

When you select a document, a description of the document appears under **Topic Description**. To select more than one document, press and hold the Ctrl key while you select the documents. Click **View Book** to view the selected document or documents in Acrobat Reader or xpdf. If you selected more than one document, all the selected documents are opened in Acrobat Reader or xpdf.

To search all the documents, type a word or word string in the **Search** field and click **Search**. The documents in which the word or word string appears are listed in order of the most occurrences. Click a document to view it, and press Ctrl+F to use the Acrobat search function, or press Alt+F to use the xpdf search function within the document.

Click **Help** for detailed information about using the Documentation Browser.

Related documentation

This *Installation and User's Guide* contains general information about the server, including how to set up the server, install supported optional devices, and configure the server. The following documentation also is available for the server. Documents that are in Portable Document Format (PDF) are on the IBM *Documentation CD*.

- *IBM Warranty Information*

This printed document contains the warranty terms and a pointer to the IBM Statement of Limited Warranty on the IBM website.

- *Safety Information*

This document is in PDF on the IBM *Documentation CD*. It contains translated caution and danger statements. Each caution and danger statement that appears in the documentation has a number that you can use to locate the corresponding statement in your language in the *Safety Information* document.

- *Safety Information Labels*

This document provides the Simplified Chinese, Mongolian, Tibetan, Uygur, and Zhuang translated versions of the product safety labels.

- *Problem Determination and Service Guide*

This document is in PDF on the IBM *Documentation CD*. It contains information to help you solve problems yourself, and it contains information for service technicians.

- *Rack Installation Instructions*

This printed document contains detailed instructions for installing your server in a rack.

- *Environmental Notices and User's Guide*

This document is in PDF on the IBM *Documentation* CD. It contains translated environmental notices.

- *IBM License Agreement for Machine Code*

This document is in PDF on the IBM *Documentation* CD. It provides translated versions of the *IBM License Agreement for Machine Code* for your product.

Depending on the server model, additional documentation might be included on the IBM *Documentation* CD.

The ToolsCenter for System x and BladeCenter is an online information center that contains information about tools for updating, managing, and deploying firmware, device drivers, and operating systems. The ToolsCenter for System x and BladeCenter is at <http://publib.boulder.ibm.com/infocenter/toolscctr/v1r0/index.jsp>.

The server might have features that are not described in the documentation that comes with the server. The documentation might be updated occasionally to include information about those features, or technical updates might be available to provide additional information that is not included in the server documentation. To check for updated documentation and technical updates, go to <http://www.ibm.com/supportportal/>.

Notices and statements in this document

The caution and danger statements in this document are also in the multilingual *Safety Information* document, which is on the IBM *Documentation* CD. Each statement is numbered for reference to the corresponding statement in your language in the *Safety Information* document.

The following notices and statements are used in this document:

- **Note:** These notices provide important tips, guidance, or advice.
- **Important:** These notices provide information or advice that might help you avoid inconvenient or problem situations.
- **Attention:** These notices indicate potential damage to programs, devices, or data. An attention notice is placed just before the instruction or situation in which damage might occur.
- **Caution:** These statements indicate situations that can be potentially hazardous to you. A caution statement is placed just before the description of a potentially hazardous procedure step or situation.
- **Danger:** These statements indicate situations that can be potentially lethal or extremely hazardous to you. A danger statement is placed just before the description of a potentially lethal or extremely hazardous procedure step or situation.

Features and specifications

The following information is a summary of the features and specifications of the server. Depending on the server model, some features might not be available, or some specifications might not apply.

Notes:

1. Racks are marked in vertical increments of 4.45 cm (1.75 inches). Each increment is referred to as a unit, or "U." A 1-U-high device is 4.45 cm (1.75 inches) tall.

2. Power consumption and heat output vary depending on the number and type of optional features that are installed and the power-management optional features that are in use.
3. The sound levels were measured in controlled acoustical environments according to the procedures specified by ISO 7779 and are reported in accordance with ISO 9296. Actual sound-pressure levels in a given location might exceed the average values stated because of room reflections and other nearby noise sources. The declared sound-power levels indicate an upper limit, below which a large number of computers will operate.

Table 1. Features and specifications

<p>Microprocessor:</p> <ul style="list-style-type: none"> • AMD Opteron • Discrete Level-1 and Level-2 cache for each core • Shared Level-3 cache • Support up to two or four multi-core microprocessors <p>Note: Use the Setup utility to determine the type and speed of the microprocessors.</p> <p>Memory:</p> <ul style="list-style-type: none"> • 32 DIMM connectors (eight per microprocessor) • Type: Registered or unbuffered, ECC, PC3-10600, DDR-3, SDRAM • Sizes: <ul style="list-style-type: none"> – 2 GB and 4 GB unbuffered DIMMs (UDIMMs) – 2 GB, 4 GB, 8 GB, and 16 GB registered DIMMs (RDIMMs) • Minimum: 4 GB • Maximum: 512 GB <ul style="list-style-type: none"> – 128 GB using UDIMMs – 512 GB using RDIMMs <p>Optical drives (Optional):</p> <ul style="list-style-type: none"> • Slim CD/DVD-ROM • Multi-drive <p>Expansion bays:</p> <ul style="list-style-type: none"> • Up to eight 3.5-inch hot-swap hard disk drive bays • Up to six 3.5-inch simple-swap hard disk drive bays with an optional tape drive <p>PCI Expansion slots:</p> <ul style="list-style-type: none"> • One PCI Express x16 slot (full-length, full-height) • One PCI Express x8 slot (half-length, low-profile) • One PCI Express x4 slot (half-length, low-profile) • One PCI Express x8 internal slot (half-length, low-profile) <p>RAID (depending on the model):</p> <ul style="list-style-type: none"> • ServeRAID-BR10iL SAS/SATA adapter v2 that provides RAID levels 0, 1, and 1E on simple-swap models • ServeRAID-M1015 SAS/SATA adapter that provides RAID levels 0, 1, and 10 with optional RAID 5/50 and SED (Self Encrypting Drive) upgrade • ServeRAID-M5014 SAS/SATA adapter that provides RAID levels 0, 1, 5, 10, and 50 with optional RAID 6/60 and SED upgrade • ServeRAID-M5015 SAS/SATA adapter that comes with a battery and provides RAID levels 0, 1, 5, 10, and 50 with optional RAID 6/60 and SED upgrade 	<p>Upgradeable microcode:</p> <p>System UEFI, FPGA, diagnostics, service processor, iBMC, and SAS microcode</p> <p>Power supply:</p> <ul style="list-style-type: none"> • Standard: One or two dual-rated power supplies (depending on the model) • Maximum of three 1100-watt ac (at 100 or 240 V ac) hot-swap power supplies for N+N or N+1 redundancy support (depending on configuration) <p>Size:</p> <ul style="list-style-type: none"> • 2U • Height: 87 mm (3.43 in.) • Depth: 727.5 mm (28.64 in.), without front panel; 747 mm (29.41 in.) with front panel • Width: 446 mm (17.56 in.), without rack EIA bracket; 482 mm (18.98 in.) with rack EIA bracket • Weight: approximately 22 kg (48.6 lb) to 33 kg (72.7 lb) depending on your configuration <p>Integrated functions:</p> <ul style="list-style-type: none"> • Integrated baseboard management controller (iBMC), which provides service processor control and monitoring functions, video controller, and remote keyboard, video, mouse, and remote hard disk drive capabilities • Light path diagnostics • Five Universal Serial Bus (USB) ports (2.0) <ul style="list-style-type: none"> – Two on rear of server – Two on front of server – One internal • Two Broadcom 5709 dual 10/100/1000 MB Ethernet controllers • AST2050 video <ul style="list-style-type: none"> – 8 MB video memory – SVGA compatible • Serial-attached SCSI (SAS) controller with RAID capabilities • Serial connector <p>Acoustical noise emissions:</p> <ul style="list-style-type: none"> • Sound power, idle: 6.6 bel declared • Sound power, operating: 6.6 bel declared <p>Airflow:</p> <ul style="list-style-type: none"> • Nominal airflow: 54 cubic feet per minute (CFM) • Typical airflow: 64 CFM • Maximum airflow: 168 CFM 	<p>Fans:</p> <ul style="list-style-type: none"> • Up to five system fans • Two types of fans (depending on the model) : <ul style="list-style-type: none"> – Single-motor (nonredundant) – Dual-motor (redundant) <p>Attention: Single-motor (nonredundant) and dual-motor (redundant) can not be mixed in the system</p> <p>Environment:</p> <ul style="list-style-type: none"> • Air temperature: <ul style="list-style-type: none"> – Server on: <ul style="list-style-type: none"> - 10°C to 35°C (50°F to 95°F); altitude: 0 to 914 m (3000 ft). - 10°C to 32°C (50°F to 90°F); altitude: 914 to 2133 m (7000 ft). – Server off: 10°C to 43°C (50.0°F to 109.4°F); maximum altitude: 2133 m (7000 ft). • Humidity: <ul style="list-style-type: none"> – Server on: 8% to 80% – Server off: 8% to 80% • Particulate contamination: <p>Attention: Airborne particulates and reactive gases acting alone or in combination with other environmental factors such as humidity or temperature might pose a risk to the server. For information about the limits for particulates and gases, see “Particulate contamination” on page 99.</p> <p>Heat output:</p> <p>Approximate heat output:</p> <ul style="list-style-type: none"> • Minimum configuration: 648 Btu per hour (190 watts) • Typical configuration: 3753 Btu per hour (1100 watts) • Design maximum configuration: <ul style="list-style-type: none"> – 5971 Btu per hour (1930 watts) at 110 V ac – 6739 Btu per hour (2150 watts) at 220 V ac <p>Electrical input:</p> <ul style="list-style-type: none"> • Sine-wave input (50/60 Hz) required • Input voltage low range: <ul style="list-style-type: none"> – Minimum: 100 V ac – Maximum: 127 V ac • Input voltage high range: <ul style="list-style-type: none"> – Minimum: 200 V ac – Maximum: 240 V ac • Approximate input kilovolt-amperes (kVA): <ul style="list-style-type: none"> – Minimum: 0.20 kVA – Typical: 1.12 kVA – Maximum: 1.95 kVA (110 V ac) – Maximum: 2.17 kVA (220 V ac)
--	--	--

International Business Machines Corporation

New Orchard Road

Armonk, New York 10504 <http://www.ibm.com/customersupport/>

Product Type:

- Computer Server

Year first manufactured:

- 2011

Internal/external power supply efficiency:

- http://www.plugloadsolutions.com/psu_reports/LITE-0N_PS-2112-2M_1100W_SO-255_Report.pdf

Maximum power (watts):

- See “Features and specifications” on page 4.

Idle state power (watts):

- 167

Sleep mode power (watts):

- Not applicable for servers.

Off mode power (watts):

- 16

Noise levels (the declared A-weighted sound power level of the computer):

- See “Features and specifications” on page 4.

Test voltage and frequency:

- 230V / 50 Hz or 60 Hz

Total harmonic distortion of the electricity supply system:

- The maximum harmonic content of the input voltage waveform will be equal or less than 2%. The qualification is compliant with EN 61000-3-2.

Information and documentation on the instrumentation set-up and circuits used for electrical testing:

- ENERGY STAR Test Method for Computer Servers; ECOVA Generalized Test Protocol for Calculating the Energy Efficiency of Internal Ac-Dc and Dc-Dc Power Supplies.

Measurement methodology used to determine information in this document:

- ENERGY STAR Servers Version 2.0 Program Requirements; ECOVA Generalized Test Protocol for Calculating the Energy Efficiency of Internal Ac-Dc and Dc-Dc Power Supplies.

What your server offers

The server uses the following features and technologies:

- **Symmetric multiprocessing (SMP)**

The server supports up to four multi-core AMD Opteron™ microprocessors. If the server comes with only one microprocessor, you can install additional microprocessors to enhance performance and provide SMP capability.

Note: As of date of this document, SUSE Linux Enterprise Server 11 Service Pack 1 does not support XEN virtualization on a server using AMD Opteron 6200 series microprocessors.

- **UEFI-compliant server firmware**

IBM System x® Server Firmware (server firmware) offers several features, including Unified Extensible Firmware Interface (UEFI) 2.1 compliance; enhanced reliability, availability, and serviceability (RAS) capabilities; and basic input/output system (BIOS) compatibility support. UEFI replaces the BIOS and defines a standard interface between the operating system, platform firmware, and external devices. UEFI-compliant System x servers are capable of booting UEFI-compliant operating systems, BIOS-based operating systems, and BIOS-based adapters as well as UEFI-compliant adapters.

Note: The server does not support DOS.

- **Integrated baseboard management controller**

The integrated baseboard management controller (iBMC) combines service processor functions, video controller, and remote presence and blue-screen capture features in a single chip. The iBMC provides advanced service processor control, monitoring, and alerting function. If an environmental condition exceeds a threshold or if a system component fails, the iBMC lights LEDs to help you diagnose the problem, records the error in the iBMC event log, and alerts you to the problem. Optionally, the iBMC also provides a virtual presence capability for remote server management capabilities. The iBMC provides remote server management through industry-standard interfaces:

- Intelligent Platform Management Interface (IPMI) version 2.0
- Simple Network Management Protocol (SNMP) version 3
- Web browser (For more information, see “Using the integrated baseboard management controller” on page 85.)

- **IBM Systems Director**

IBM Systems Director is a platform-management foundation that streamlines the way you manage physical and virtual systems in a heterogeneous environment. By using industry standards, IBM Systems Director supports multiple operating systems and virtualization technologies for IBM and non-IBM x86 platforms. For more information, see the “IBM Systems Director” on page 12.

- **IBM Electronic Service Agent**

IBM Electronic Service Agent is a software tool that monitors the server for hardware error events and automatically submits electronic service requests to IBM service and support. Also, it can collect and transmit system configuration information on a scheduled basis so that the information is available to you and your support representative. It uses minimal system resources, is available free of charge, and can be downloaded from the web. For more information and to download Electronic Service Agent, go to <http://www.ibm.com/support/electronic/>.

- **Large system-memory capacity**

The server supports up to 512 GB of system memory when registered DIMMs are installed. The server supports up to 128 GB of system memory when unbuffered DIMMs are installed. The memory controller supports error correcting code (ECC) for up to 32 industry-standard PC3-10600, registered or unbuffered, DDR-3, synchronous dynamic random access memory (SDRAM) dual inline memory modules (DIMMs).

- **IBM ServerGuide Setup and Installation CD**

The *ServerGuide Setup and Installation CD*, which you can download from the web, provides programs to help you set up the server and install a Windows operating system. The ServerGuide program detects installed optional hardware devices and provides the correct configuration programs and device drivers. For more information about the *ServerGuide Setup and Installation CD*, see “Using the ServerGuide Setup and Installation CD” on page 83.

- **Integrated network support**

The server comes with two integrated Broadcom 5709 dual Gigabit Ethernet controllers, which supports connection to a 10 Mbps, 100 Mbps, or 1000 Mbps network. For more information, see “Configuring the Broadcom Gigabit Ethernet controller” on page 87.

- **Integrated Trusted Platform Module (TPM)**

This integrated security chip performs cryptographic functions and stores private and public secure keys. It provides the hardware support for the Trusted Computing Group (TCG) specification. You can download the software to support the TCG specification, when the software is available.

- **Large data-storage capacity and hot-swap capability**

The hot-swap models of the server support up to eight 3.5-inch hot-swap hard disk drives. With the hot-swap feature, you can add, remove, and replace hard disk drives without turning off the server.

The simple-swap models of the server support up to six simple-swap hard disk drives with an optional tape drive.

- **Light path diagnostics**

Light path diagnostics provides LEDs to help you diagnose problems. For more information, see the section about light path diagnostics in the *Problem Determination and Service Guide*.

- **Dynamic System Analysis (DSA) Preboot diagnostic programs**

The DSA Preboot diagnostic programs are stored in integrated USB memory and collect and analyze system information to aid in diagnosing server problems. The diagnostic programs collect the following information about the server:

- Event logs for ServeRAID controllers and service processors
- Hard disk drive health
- Installed hardware
- Light path diagnostics status
- Network interfaces and settings
- RAID controller configuration
- Service processor status and configuration
- System configuration
- Vital product data, firmware, and UEFI configuration

For additional information about DSA, see the *Problem Determination and Service Guide* on the *IBM Documentation CD*.

- **Redundant power capabilities**

The server supports up to three 1100-watt hot-swap power supplies. If the server comes with only one power supply for a two-microprocessor configuration or two power supplies for a four-microprocessor configuration, you can install an additional power supply to add redundant power capabilities. If the maximum load on the server is less than 1100 watts and a problem occurs with one of the power supplies, the other power supply can meet the power requirements.

- **ServeRAID support**

The server supports ServeRAID controllers to create redundant array of independent disks (RAID) configurations.

Reliability, availability, and serviceability

Three important server design features are reliability, availability, and serviceability (RAS). The RAS features help to ensure the integrity of the data that is stored in the server, the availability of the server when you need it, and the ease with which you can diagnose and correct problems.

The server has the following RAS features:

- Advanced memory features:
 - Single-bit memory error detection
 - Single-bit memory error hardware correction
 - Multi single-bit memory error recovery and corrections
 - Uncorrectable error (UE) detection
 - Full array memory mirroring (FAMM) redundancy
 - Automatic failover recovery for UEs when FAMM is configured
 - Automated logical removal of failed DIMMs on reboots prior to replacement
 - Automatic address parity checking during writes and reads
- Automatic BIOS recovery (ABR) for UEFI
- Automatic error retry and recovery
- Automatic restart after a power failure
- Availability of microcode and diagnostic levels
- Integrated baseboard management controller (service processor)
- Built-in, menu-driven electrically erasable programmable ROM (EEPROM) based setup, system configuration, and diagnostic programs
- Built-in monitoring for fan, power, temperature, voltage, and power-supply redundancy
- Error codes and messages
- Error correcting code (ECC) L2 cache and system memory
- Fault-resistant startup
- Hot-swap hard disk drives
- IBM Systems Director workgroup-hardware-management tool
- Information and light path diagnostics LED panels
- Service processor adapter for remote systems management
- Parity checking on the SAS bus and PCI Express buses
- Power managed and Advanced Configuration and Power Interface (ACPI) compliant
- Power-on self-test (POST)
- Predictive Failure Analysis (PFA) alerts
- Redundant hot-swap capability
 - Cooling fans with speed-sensing capability (depending on the model)
 - Power supplies
- Remind button to temporarily flash the system-error LED
- Remote system problem-determination support
- ROM-based diagnostic programs
- Standby voltage for systems-management features and monitoring
- Startup (boot) from LAN using Preboot Execution Environment (PXE) protocol
- System auto-configuring from the configuration menu
- System error logging
- Upgradeable microcode for POST, iBMC, diagnostics, service processor, and read-only memory (ROM) resident code, locally or over the LAN
- Vital product data (VPD) on microprocessors, system boards, power supplies, and SAS (hot-swap-drive) backplane
- Wake on LAN capability

IBM Systems Director

IBM Systems Director is a platform-management foundation that streamlines the way you manage physical and virtual systems in a heterogeneous environment. By using industry standards, IBM Systems Director supports multiple operating systems and virtualization technologies in IBM and non-IBM x86 platforms.

Through a single user interface, IBM Systems Director provides consistent views for viewing managed systems, determining how these systems relate to one another, and identifying their statuses, helping to correlate technical resources with business needs. A set of common tasks that are included with IBM Systems Director provides many of the core capabilities that are required for basic management, which means instant out-of-the-box business value. These common tasks include discovery, inventory, configuration, system health, monitoring, updates, event notification, and automation for managed systems.

The IBM Systems Director web and command-line interfaces provide a consistent interface that is focused on driving these common tasks and capabilities:

- Discovering, navigating, and visualizing systems on the network with the detailed inventory and relationships to the other network resources
- Notifying users of problems that occur on systems and the ability to isolate the sources of the problems
- Notifying users when systems need updates and distributing and installing updates on a schedule
- Analyzing real-time data for systems and setting critical thresholds that notify the administrator of emerging problems
- Configuring settings of a single system and creating a configuration plan that can apply those settings to multiple systems
- Updating installed plug-ins to add new features and functions to the base capabilities
- Managing the life cycles of virtual resources

For more information about IBM Systems Director, see the IBM Systems Director Information Center at http://publib.boulder.ibm.com/infocenter/director/v6r1x/index.jsp?topic=/director_6.1/fqm0_main.html and the Systems Management web page at <http://www.ibm.com/systems/management/>, which presents an overview of IBM Systems Management and IBM Systems Director.

The Update*Xpress* System Pack Installer (UXSPI)

The Update*Xpress* System Pack Installer detects supported and installed device drivers and firmware in the server and installs available updates. For additional information and to download the Update*Xpress* System Pack Installer, go to the ToolsCenter for System x and BladeCenter at <http://publib.boulder.ibm.com/infocenter/toolsctr/v1r0/index.jsp> and click **Update*Xpress* System Pack Installer**.

Server controls, LEDs, and power

This section describes the controls, light-emitting diodes (LEDs), connectors on the front and rear of the server, and how to turn the server on and off.

Note: The illustrations in this document might differ slightly from your server.

Front view

The following illustration shows the controls, LEDs, and connectors on the front of the server. (See “Operator information panel” on page 14 for information about the operator information panel.) The DVD drive is optional in some models.

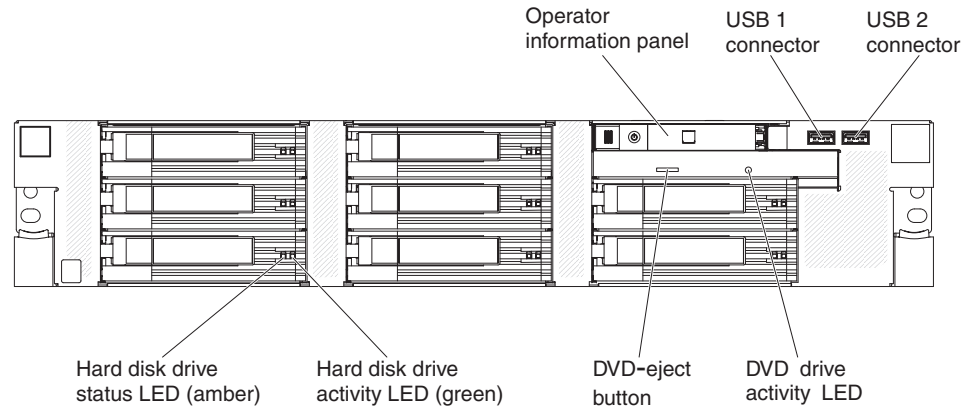

DVD-eject button (optional): Press this button to release a CD or DVD from the DVD drive.

DVD drive activity LED (optional): When this LED is lit, it indicates that the DVD drive is in use.

USB connectors: Connect USB devices to these connectors.

Hard disk drive activity LED: Each hot-swap hard disk drive has an activity LED. When this LED is flashing, it indicates that the drive is in use.

Hard disk drive status LED: Each hot-swap hard disk drive has a status LED. When this LED is lit, it indicates that the drive has failed. If an optional IBM ServeRAID controller is installed in the server, when this LED is flashing slowly (one flash per second), it indicates that the drive is being rebuilt. When the LED is flashing rapidly (three flashes per second), it indicates that the controller is identifying the drive.

Operator information panel

The following illustration shows the controls and LEDs on the operator information panel.

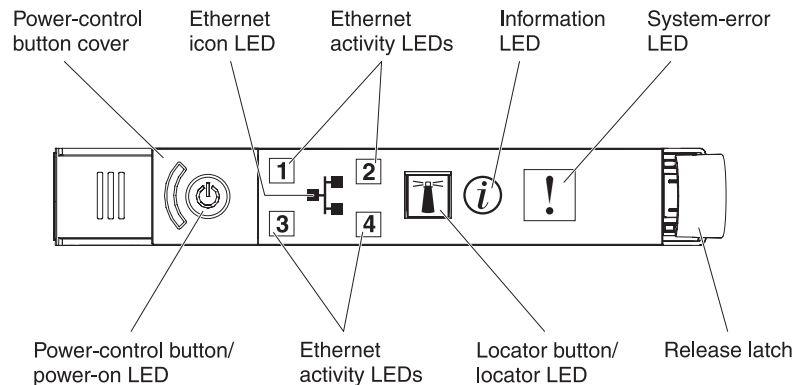

The following controls and LEDs are on the operator information panel:

- **Power-control button and power-on LED:** Press this button to turn the server on and off manually or to wake the server from a reduced-power state. The states of the power-on LED are as follows:
 - Off:** AC power is not present, or the power supply or the LED itself has failed.
 - Flashing rapidly (4 times per second):** The server is turned off and is not ready to be turned on. The power-control button is disabled. Approximately 1 minute after the server is connected to ac power, the power-control button becomes active.
 - Flashing slowly (once per second):** The server is turned off and is ready to be turned on. You can press the power-control button to turn on the server.
 - Lit:** The server is turned on.
 - Fading on and off:** The server is in a reduced-power state. To wake the server, press the power-control button or use the iBMC web interface. For information about logging on to the iBMC web interface, see “Logging on to the web interface” on page 86.
- **Note:** Approximately 1 minute after the server is turned on, the screen displays the boot process status. Depending on your server configuration, the operating system welcome screen displays after 1 - 3 minutes.
- **Ethernet icon LED:** This LED lights the Ethernet icon.
- **Information LED:** When this LED is lit, it indicates that a noncritical event has occurred. Check the system-event log for additional information.
- **System-error LED:** When this LED is lit, it indicates that a system error has occurred. An LED on the light path diagnostics panel is also lit to help isolate the error.
- **Locator button and locator LED:** Use this LED to visually locate the server among other servers. Press this button to turn on or turn off this LED locally. You can use IBM Systems Director to light this LED remotely
- **Ethernet port activity LEDs:** When one of these LEDs is lit, it indicates that the server is transmitting to or receiving signals from the Ethernet LAN that is connected to the Ethernet port that corresponds to that LED.

Light path diagnostics panel

The light path diagnostics panel is on the top of the operator information panel.

To access the light path diagnostics panel, slide the blue release button on the operator information panel to the left. Pull forward on the operator information panel until the hinge of the panel is free of the server chassis. Then pull down on the operator information panel, so that you can view the light path diagnostics panel information.

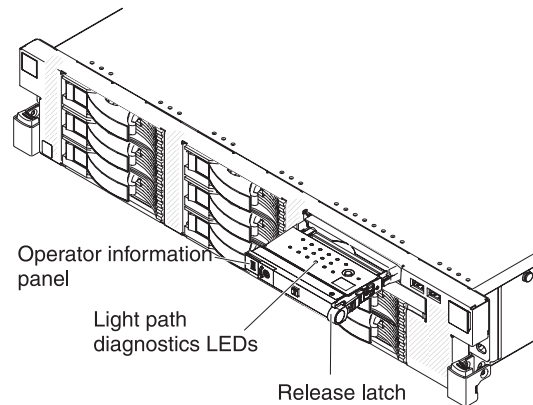

Notes:

1. Do not run the server for an extended period of time while the light path diagnostics panel is pulled out of the server.
2. Light path diagnostics LEDs remain lit only while the server is connected to power.

The following illustration shows the controls and LEDs on the light path diagnostics panel.

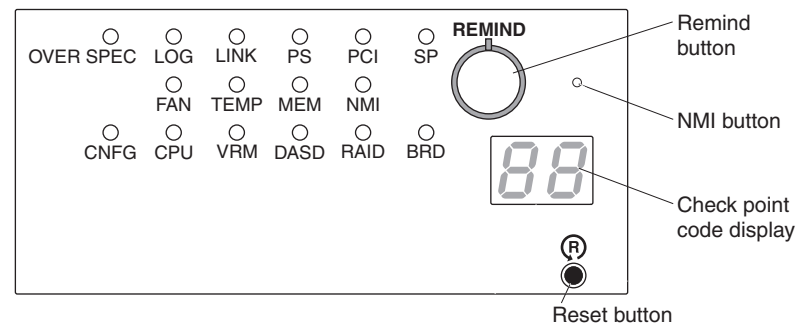

- **Remind button:** This button places the system-error LED on the front panel into Remind mode. In Remind mode, the system-error LED flashes once every 2 seconds until the problem is corrected, the server is restarted, or a new problem occurs.
By placing the system-error LED indicator in Remind mode, you acknowledge that you are aware of the last failure but will not take immediate action to correct the problem. The remind function is controlled by the iBMC.
- **NMI button:** Press this button to force a nonmaskable interrupt to the microprocessor, if you are directed to do so by IBM service.
- **Checkpoint code display:** This display provides a checkpoint code that indicates the point at which the system stopped during the boot block and POST. A checkpoint code is either a byte or a word value that is produced by UEFI. The display does not provide error codes or suggest components to be replaced.

- **Reset button:** Press this button to reset the server and run the power-on self-test (POST). You might have to use a pen or the end of a straightened paper clip to press the button. The reset button is in the lower-right corner of the light path diagnostics panel.

For more information about light path diagnostics, see the *Problem Determination and Service Guide* on the IBM Documentation CD.

Rear view

The following illustration shows the connectors on the rear of the server.

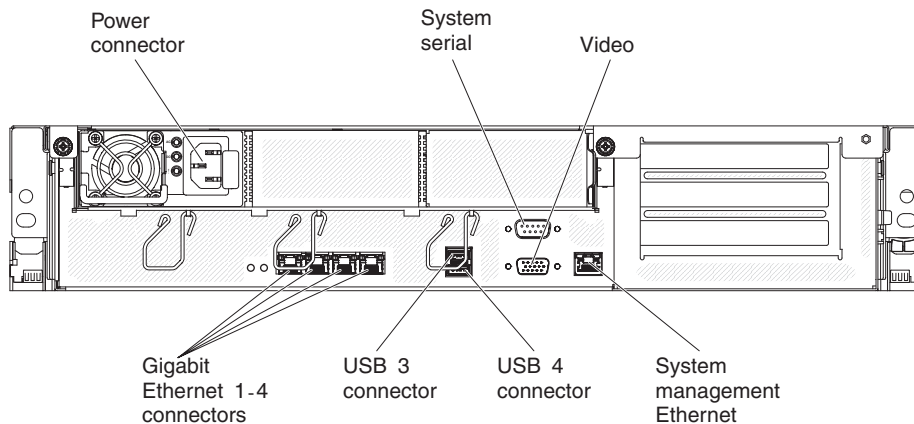

Power-cord connector: Connect the power cord to this connector.

System-management connector: Use this connector to connect the server to a network for systems-management information control. This connector is used only by the integrated baseboard management controller (iBMC).

USB connectors: Connect USB devices, such as a USB mouse or keyboard, to these connectors.

Video connector: Connect a monitor to this connector.

Serial connector: Connect a 9-pin serial device to this connector. The serial port is shared with the integrated baseboard management controller (iBMC). The iBMC can take control of the shared serial port to perform text console redirection and to redirect serial traffic, using Serial over LAN (SOL).

Gigabit Ethernet connectors: Use these connectors to connect the server to a network. When you enable shared Ethernet for iBMC in the Setup utility, you can access the iBMC using either the Ethernet 1 or the system-management Ethernet connector.

Rear view LEDs

The following illustration shows the LEDs on the rear of the server. For more information about solving power-supply problems, see the *Problem Determination and Service Guide*.

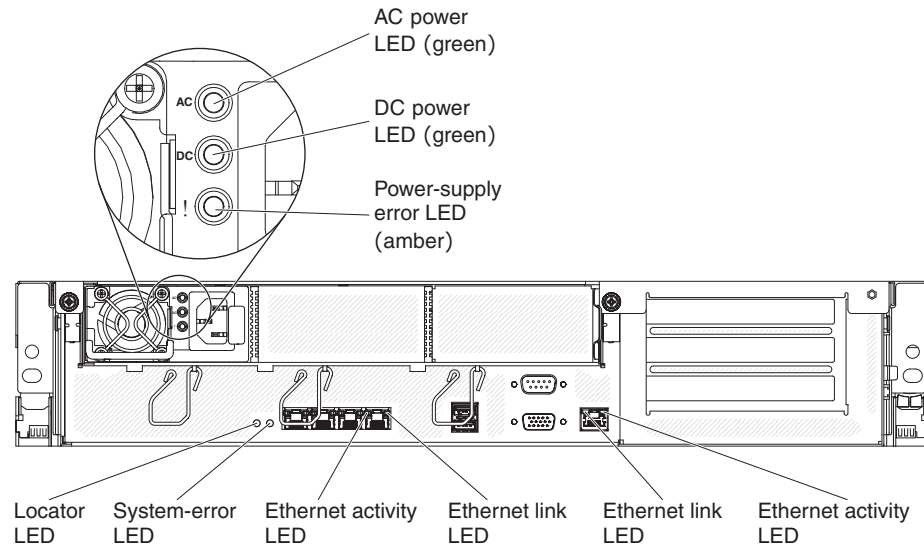

AC power LED: Each hot-swap power supply has an ac power LED and a dc power LED. When the ac power LED is lit, it indicates that sufficient power is coming into the power supply through the power cord. During typical operation, both the ac and dc power LEDs are lit. For any other combination of LEDs, see the *Problem Determination and Service Guide*.

DC power LED: Each hot-swap power supply has a dc power LED and an ac power LED. When the dc power LED is lit, it indicates that the power supply is supplying sufficient dc power to the system. During typical operation, both the ac and dc power LEDs are lit. For any other combination of LEDs, see the *Problem Determination and Service Guide*.

Power-supply error LED: When the power-supply error LED is lit, it indicates that the power supply has failed. See the *Problem Determination and Service Guide* for detailed information about power-supply errors.

Ethernet activity LEDs: When these LEDs are lit, they indicate that the server is transmitting to or receiving signals from the Ethernet LAN that is connected to the Ethernet port.

For the system-management port, this LED is on to indicate that there is an active link connection on the 100BASE-T. When this LED is off, this indicates an active link connection on the 10BASE-TX interface.

Ethernet link LEDs: When these LEDs are lit, they indicate that there is an active link connection on the 10BASE-T, 100BASE-TX, or 1000BASE-TX interface for the Ethernet port.

System-error LED: When this LED is lit, it indicates that a system error has occurred. An LED on the light path diagnostics panel is also lit to help isolate the error. This LED is functionally equivalent to the system-error LED on the front of the server.

Locator LED: Use this LED to visually locate the server among other servers. You can use IBM Systems Director to light this LED remotely. This LED is functionally equivalent to the locator LED on the front of the server.

Server power features

When the server is connected to an ac power source but is not turned on, the operating system does not run, and all core logic except for the integrated baseboard management controller (iBMC) is shut down; however, the server can respond to requests from the iBMC, such as a remote request to turn on the server. The power-on LED flashes to indicate that the server is connected to ac power but not turned on.

Turning on the server

Approximately 1 minute after the server is connected to ac power, the power-control button becomes active, and one or more fans might start running to provide cooling while the server is connected to power. You can turn on the server and start the operating system by pressing the power-control button.

Note: Approximately 1 minute after the server is turned on, the screen displays the boot process status. Depending on your server configuration, the operating system welcome screen displays after 1 - 3 minutes.

The server can also be turned on in any of the following ways:

- If a power failure occurs while the server is turned on, the server will restart automatically when power is restored.
- The systems-management software can turn on the server remotely.
- If your operating system supports the Wake on LAN feature, the Wake on LAN feature can turn on the server.

Note: Some memory is reserved for various system resources and is unavailable to the operating system. The amount of memory that is reserved for system resources depends on the operating system, the configuration of the server, and the configured PCI options.

Turning off the server

When you turn off the server and leave it connected to ac power, the server can respond to requests from the iBMC, such as a remote request to turn on the server. While the server remains connected to ac power, one or more fans might continue to run. To remove all power from the server, you must disconnect it from the power source.

Some operating systems require an orderly shutdown before you turn off the server. See your operating-system documentation for information about shutting down the operating system.

Statement 5:



CAUTION:

The power control button on the device and the power switch on the power supply do not turn off the electrical current supplied to the device. The device also might have more than one power cord. To remove all electrical current from the device, ensure that all power cords are disconnected from the power source.

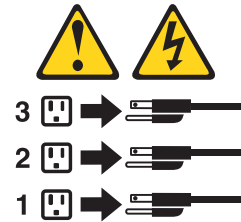

The server can be turned off in any of the following ways:

- You can turn off the server from the operating system, if your operating system supports this feature. After an orderly shutdown of the operating system, the server will be turned off automatically.
- You can press the power-control button to start an orderly shutdown of the operating system and turn off the server, if your operating system supports this feature.
- If the operating system stops functioning, you can press and hold the power-control button for more than 4 seconds to turn off the server.
- If the Wake on LAN feature turned on the server, the Wake on LAN feature can turn off the server.
- The iBMC can turn off the server as an automatic response to a critical system failure.
- You can turn off the server through a request from the iBMC.

Chapter 2. Installing optional devices

This chapter provides detailed instructions for installing optional hardware devices in the server.

In addition to the instructions in this chapter for installing optional hardware devices, updating firmware and device drivers, and completing the installation, IBM Business Partners must also complete the steps in “Instructions for IBM Business Partners.”

Important: To help ensure that the devices that you install work correctly and do not introduce problems, observe the following precautions:

1. Make sure that the server and the installed firmware levels support the devices that you are installing. If necessary, update the UEFI and iBMC firmware and any other firmware that is stored on the system boards. For information about where firmware is stored in the server, see Chapter 6, “Configuration information and instructions,” in the *Problem Determination and Service Guide*. For a list of supported optional devices for the server, see <http://www.ibm.com/systems/info/x86servers/serverproven/compat/us/>.
2. Before you install optional hardware devices, make sure that the server is working correctly. Start the server and make sure that the operating system starts, if an operating system is installed, or that a 19990305 error code is displayed, indicating that an operating system was not found but the server is otherwise working correctly. If the server is not working correctly, see the *Problem Determination and Service Guide* for information about how to run diagnostics.
3. Follow the installation procedures in this chapter and use the correct tools. Incorrectly installed devices can cause system failures because of damaged pins in sockets or connectors, loose cabling, or loose components.
4. Use the best practices to apply current firmware and device-driver updates for the server and optional devices. To download the *IBM System x Firmware Update Best Practices* document, go to <http://www.ibm.com/support/entry/portal/docdisplay?brand=50000020&Indocid=MIGR-5082923>. Additional hints and tips are available from the following sites:
 - IBM support: <http://www.ibm.com/supportportal/>
 - System x configuration tools: <http://www.ibm.com/systems/x/hardware/configtools.html>

Instructions for IBM Business Partners

In addition to the instructions in this chapter for installing optional hardware devices, updating firmware and device drivers, and completing the installation, IBM Business Partners must also complete the following steps:

1. After you have confirmed that the server starts correctly and recognizes the newly installed devices and that no error LEDs are lit, run the Dynamic System Analysis (DSA) stress tests. For information about using DSA, see the *Problem Determination and Service Guide*.
2. Shut down and restart the server multiple times to ensure that the server is correctly configured and functions correctly with the newly installed devices.
3. Save the DSA log as a file and send it to IBM. For information about transferring data and logs, see http://publib.boulder.ibm.com/infocenter/toolsctr/v1r0/index.jsp?topic=/dsa/dsa_main.html.
4. To ship the server, repackage it in the original undamaged packing material and observe IBM procedures for shipping.

Support information for IBM Business Partners is available at <http://www.ibm.com/partnerworld/>.

How to send DSA data to IBM

Before you send diagnostic data to IBM, read the terms of use at <http://www.ibm.com/de/support/ecurep/terms.html>.

You can use any of the following methods to send diagnostic data to IBM:

- **Standard upload:** http://www.ibm.com/de/support/ecurep/send_http.html
- **Standard upload with the system serial number:** http://www.ecurep.ibm.com/app/upload_hw
- **Secure upload:** http://www.ibm.com/de/support/ecurep/send_http.html#secure
- **Secure upload with the system serial number:** https://www.ecurep.ibm.com/app/upload_hw

Server components

The following illustration shows the major components in the server. The illustrations in this document might differ slightly from your hardware.

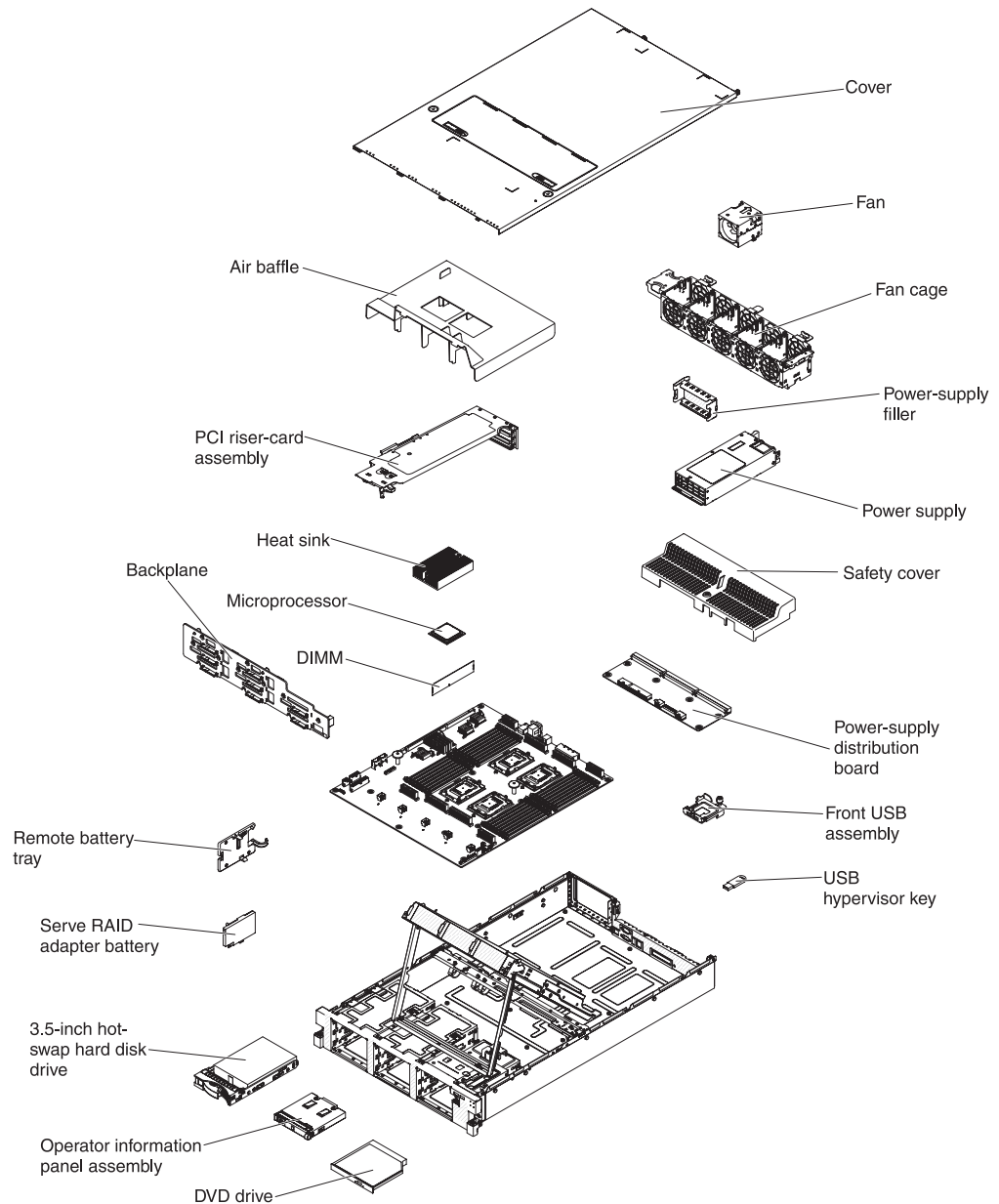

Blue on a component indicates touch points, where you can grip the component to remove it from or install it in the server, open or close a latch, and so on.

Orange on a component or an orange label on or near a component indicates that the component can be hot-swapped, which means that if the server and operating system support hot-swap capability, you can remove or install the component while the server is running. (Orange can also indicate touch points on hot-swap components.) See the instructions for removing or installing a specific hot-swap component for any additional procedures that you might have to perform before you remove or install the component.

System-board internal connectors

The following illustration shows the internal connectors on the system board.

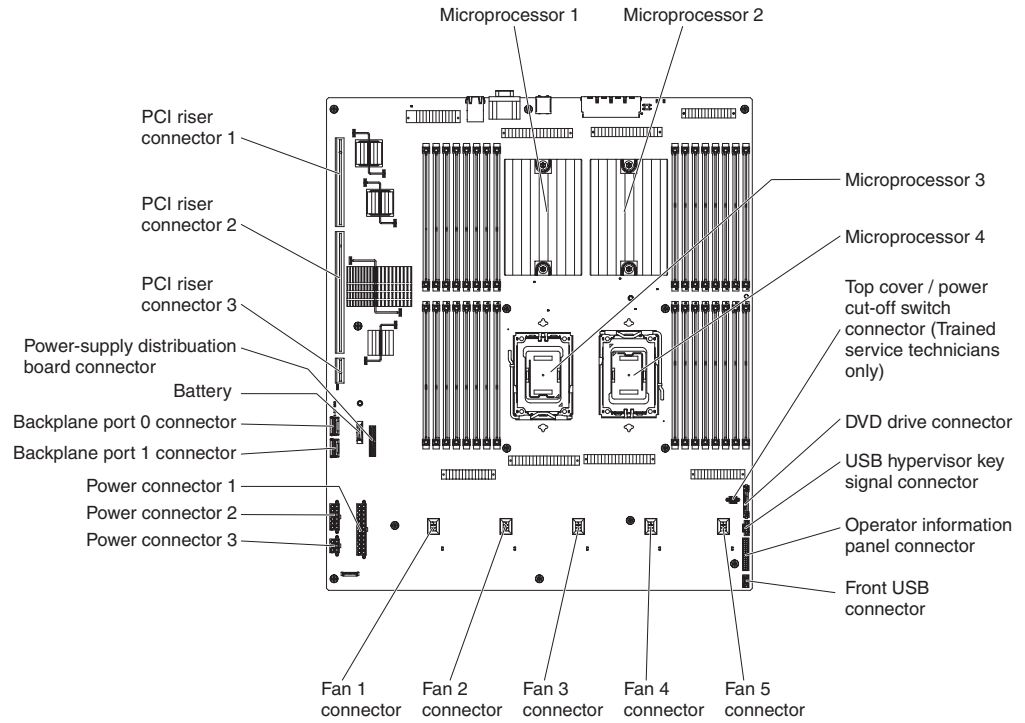

System-board DIMM connectors

The following illustration shows the DIMM connectors on the system board.

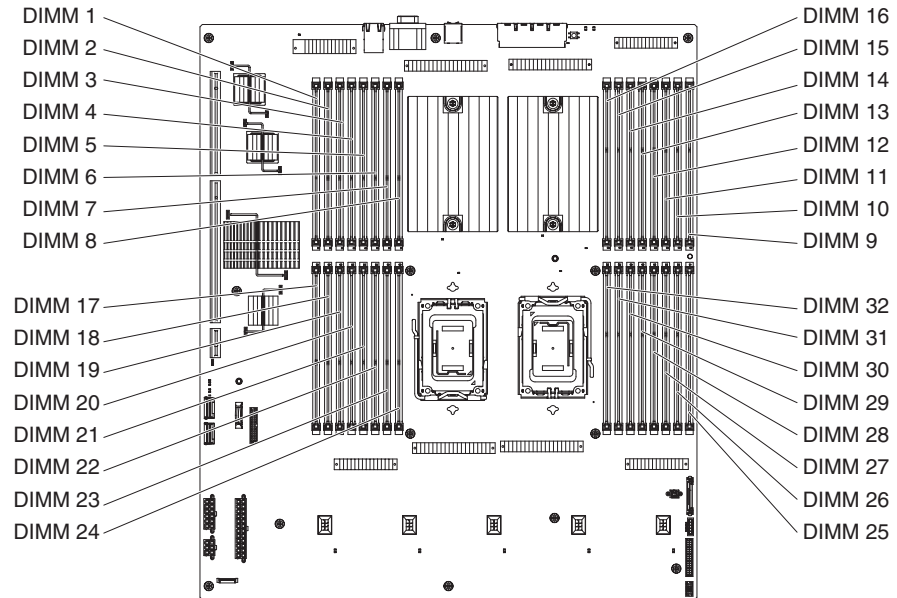

System-board external connectors

The following illustration shows the external connectors and the light path diagnostics button on the system board.

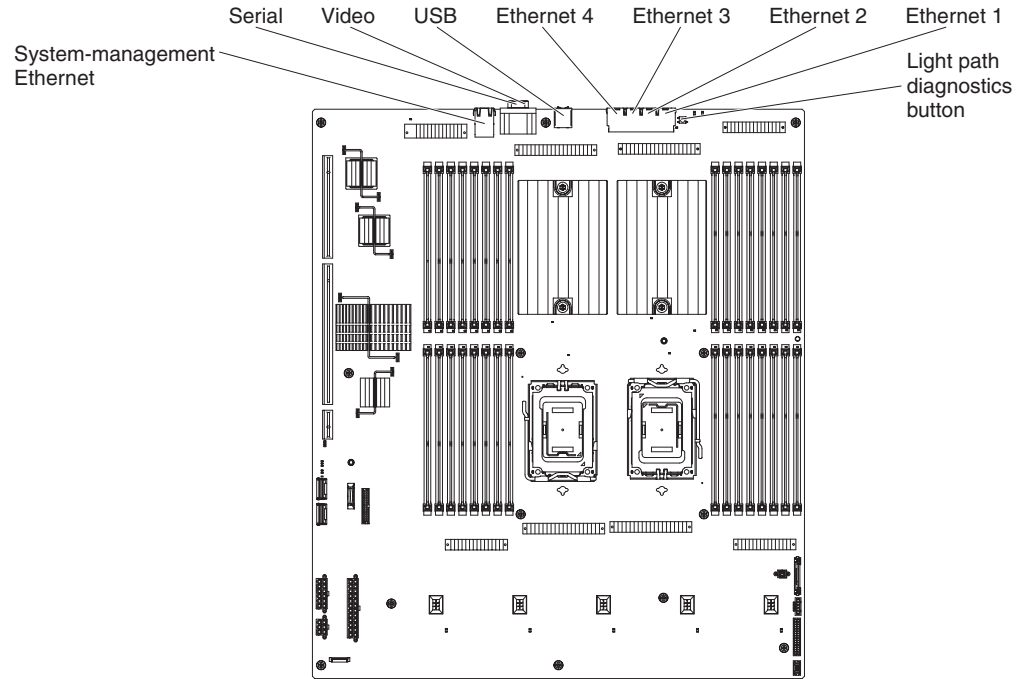

System-board jumpers

The following illustration shows the jumpers on the system board.

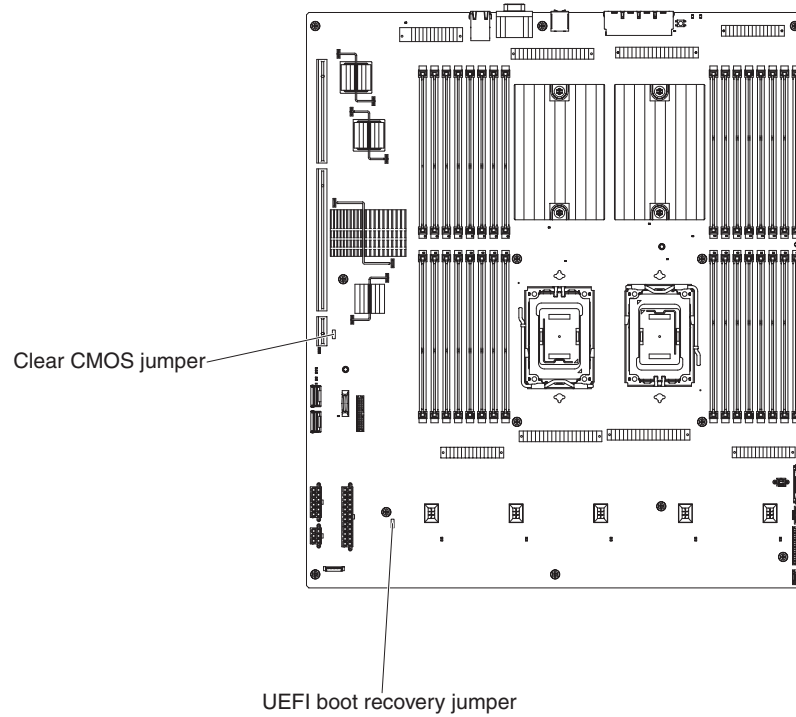

Table 2 describes the function of each jumper block.

Table 2. System board jumpers

Jumper number	Jumper name	Jumper setting
J57	Clear CMOS jumper	<ul style="list-style-type: none"> • Pins 1 and 2: Normal (default) - This keeps the CMOS data. • Pins 2 and 3: This clears the CMOS data such as the power-on password and administrator password, and loads the default UEFI settings. <p>Notes:</p> <ol style="list-style-type: none"> 1. If the clear CMOS jumper did not reset the system date and time, use the clear CMOS jumper again to load the default settings. 2. You may also use the Advanced Settings Utility (ASU) to load the default UEFI settings (see “Using the IBM Advanced Settings Utility program” on page 88).

Table 2. System board jumpers (continued)

Jumper number	Jumper name	Jumper setting
J117	UEFI boot recovery jumper	<ul style="list-style-type: none"> • Pins 1 and 2: Normal (default) Loads the primary UEFI firmware ROM page. • Pins 2 and 3: Loads the secondary (backup) UEFI firmware ROM page.
<p>Notes:</p> <ul style="list-style-type: none"> • If no jumper is present, the server responds as if a jumper is on pins 1 and 2. • Changing the position of the UEFI boot recovery jumper from pins 1 and 2 to pins 2 and 3 before the server is turned on sets the UEFI recovery process. Do not change the jumper pin position after the server is turned on. This can cause an unpredictable problem. 		

System-board LEDs

The following illustration shows the light-emitting diodes (LEDs) on the system board.

Notes:

1. Error LEDs remain lit only while the server is connected to power. If you disconnect power to the server, you can press and hold the light path diagnostics button to light the error LEDs on the system board.
2. You can also view the error LED status on the fan cage and the PCI riser-card assembly.

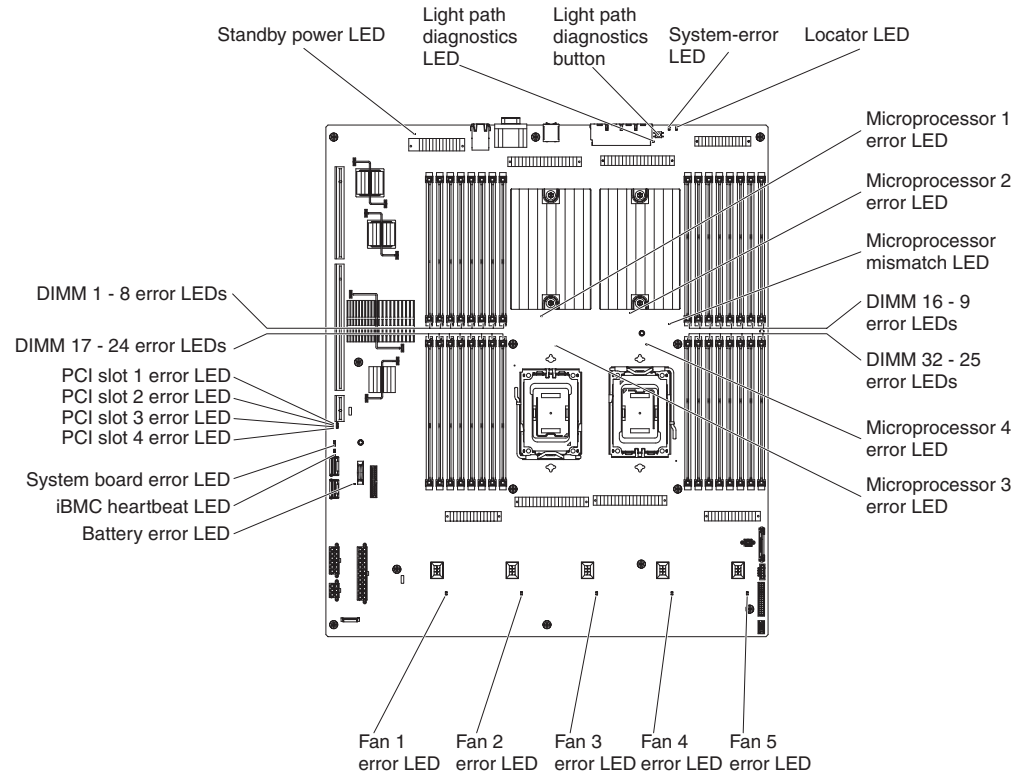

PCI riser-card adapter connectors

The following illustration shows the connectors on the PCI riser cards for user-installable PCI adapters.

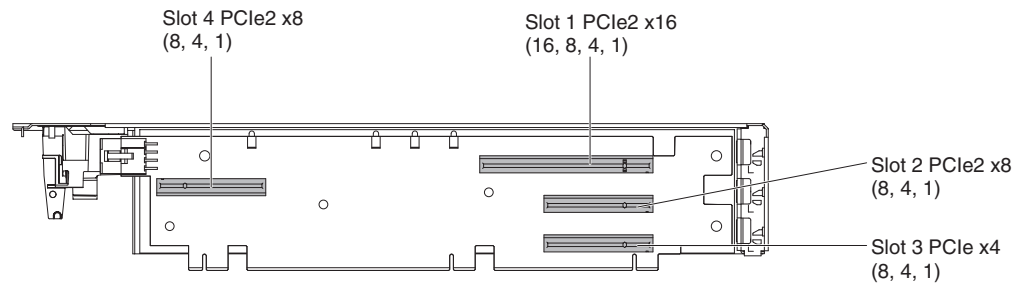

Installation guidelines

Attention: Static electricity that is released to internal server components when the server is powered-on might cause the system to halt, which might result in the loss of data. To avoid this potential problem, always use an electrostatic-discharge wrist strap or other grounding system when removing or installing a hot-swap device.

Before you install optional devices, read the following information:

- Make sure that the devices that you are installing are supported. For a list of supported optional devices for the server, see <http://www.ibm.com/systems/info/x86servers/serverproven/compat/us/>.
- Read the safety information that begins on page vii and “Handling static-sensitive devices” on page 32. This information will help you work safely.
- When you install your new server, take the opportunity to download and apply the most recent firmware updates. This step will help to ensure that any known issues are addressed and that your server is ready to function at maximum levels of performance. To download firmware updates for your server, go to <http://www.ibm.com/support/fixcentral/>.

Important: Some cluster solutions require specific code levels or coordinated code updates. If the device is part of a cluster solution, verify that the latest level of code is supported for the cluster solution before you update the code.

For additional information about tools for updating, managing, and deploying firmware, see the ToolsCenter for System x and BladeCenter at <http://publib.boulder.ibm.com/infocenter/toolsctr/v1r0/index.jsp>.

- Observe good housekeeping in the area where you are working. Place removed covers and other parts in a safe place.
- Do not attempt to lift an object that you think is too heavy for you. If you have to lift a heavy object, observe the following precautions:
 - Make sure that you can stand safely without slipping.
 - Distribute the weight of the object equally between your feet.
 - Use a slow lifting force. Never move suddenly or twist when you lift a heavy object.
 - To avoid straining the muscles in your back, lift by standing or by pushing up with your leg muscles.
- Make sure that you have an adequate number of properly grounded electrical outlets for the server, monitor, and other devices.

- Back up all important data before you make changes to disk drives.
- Have a small flat-blade screwdriver available.
- To view the error LEDs on the system board and internal components, press the light path button on the system board when the server is not connected to power.
- You do not have to turn off the server to install or replace hot-swap power supplies, hot-swap hard disk drives, hot-swap fans, or hot-plug Universal Serial Bus (USB) devices. However, you must turn off the server before you perform any steps that involve removing or installing adapter cables.
- Blue on a component indicates touch points, where you can grip the component to remove it from or install it in the server, open or close a latch, and so on.
- Orange on a component or an orange label on or near a component indicates that the component can be hot-swapped, which means that if the server and operating system support hot-swap capability, you can remove or install the component while the server is running. (Orange can also indicate touch points on hot-swap components.) See the instructions for removing or installing a specific hot-swap component for any additional procedures that you might have to perform before you remove or install the component.
- When you are finished working on the server, reinstall all safety shields, guards, labels, and ground wires.
- For a list of supported optional devices for the server, see <http://www.ibm.com/servers/eserver/serverproven/compat/us/>.

A single-power-supply server operating at 100 V or 240 V ac

One power supply operating at 100 V or 240 V ac supports a server with minimum two-microprocessor configuration, but it does not support power redundancy.

System reliability guidelines

To help ensure proper cooling and system reliability, make sure that the following requirements are met:

- Each of the drive bays has a drive or an electromagnetic compatibility (EMC) shield installed in it.
- If the server has redundant power, each of the power-supply bays has a power supply or EMC shield installed in it.
- There is adequate space around the server to allow the server cooling system to work properly. Leave approximately 50 mm (2.0 in.) of open space around the front and rear of the server. Do not place objects in front of the fans. For proper cooling and airflow, replace the top cover and the fan door before you turn on the server. Operating the server for extended periods of time (more than 30 minutes) with the fan door removed might damage server components.
- You have followed the cabling instructions that come with optional adapters.
- You have replaced a failed fan within 48 hours.
- You have replaced a hot-swap drive within 2 minutes of removal.
- For redundant and hot-swappable power supply operation, the power supplies are connected to 100-240 V ac.
- Microprocessor sockets 1 - 4 each always contain either a socket dust cover or a microprocessor and heat sink.

Notes:

1. The server automatically shuts down when the top cover is removed. The server will not turn on without the top cover installed.
2. Hard disk drive temperature sensing is not supported.

Handling static-sensitive devices

Attention: Static electricity can damage the server and other electronic devices. To avoid damage, keep static-sensitive devices in their static-protective packages until you are ready to install them.

To reduce the possibility of damage from electrostatic discharge, observe the following precautions:

- Limit your movement. Movement can cause static electricity to build up around you.
- Wear an electrostatic-discharge wrist strap, if one is available.
- Handle the device carefully, holding it by its edges or its frame.
- Do not touch solder joints, pins, or exposed circuitry.
- Do not leave the device where others can handle and damage it.
- While the device is still in its static-protective package, touch it to an *unpainted* metal surface on the outside of the server for at least 2 seconds. This drains static electricity from the package and from your body.
- Remove the device from its package and install it directly into the server without setting down the device. If it is necessary to set down the device, put it back into its static-protective package. Do not place the device on the server cover or on a metal surface.
- Take additional care when you handle devices during cold weather. Heating reduces indoor humidity and increases static electricity.

Internal cable routing and connectors

This section provides information about internal cable routing for major components in the server.

Hot-swap hard disk drive backplane cable connections

The following illustration shows the internal routing of the hot-swap hard disk drive backplane cables.

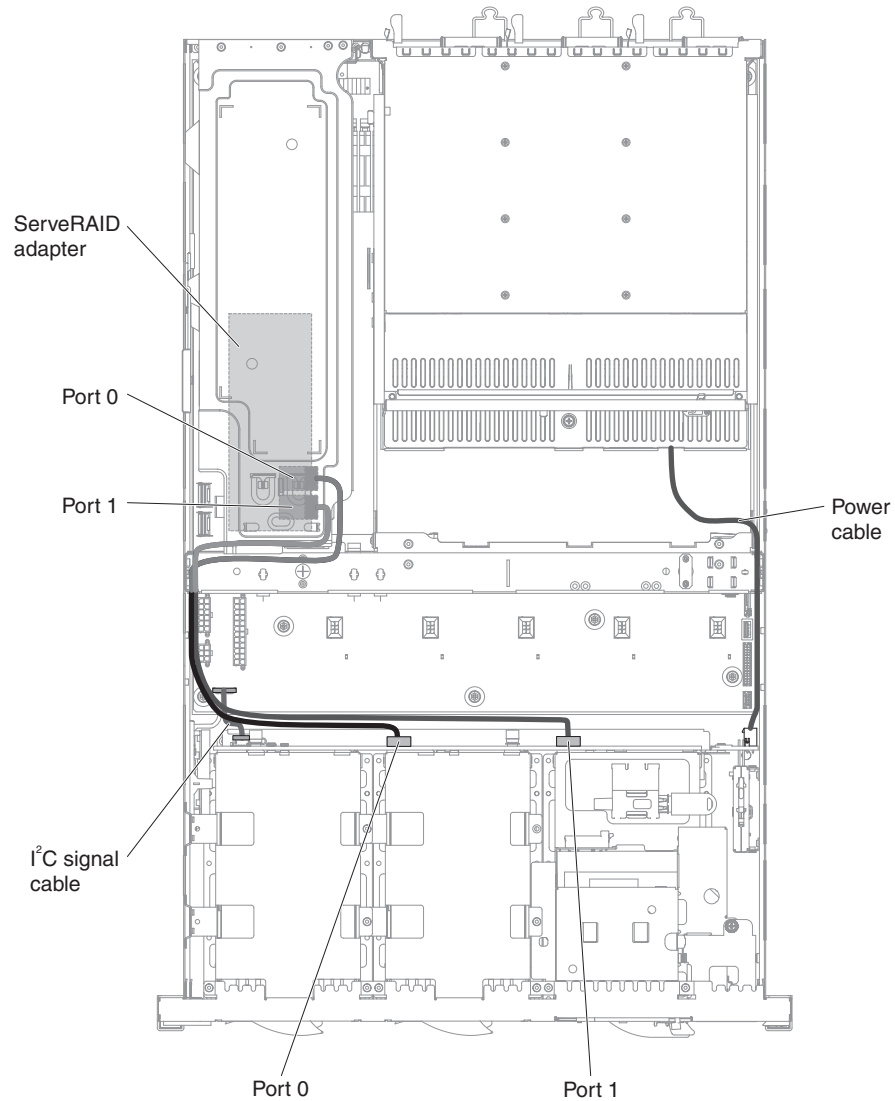

Simple-swap hard disk drive backplate cable connections

The following illustration shows the internal routing of the simple-swap hard disk drive backplate cables to the connectors on the ServeRAID adapter and system board.

Note: You must disengage the signal cable from the cable clip on the backplate to connect it to the adapter.

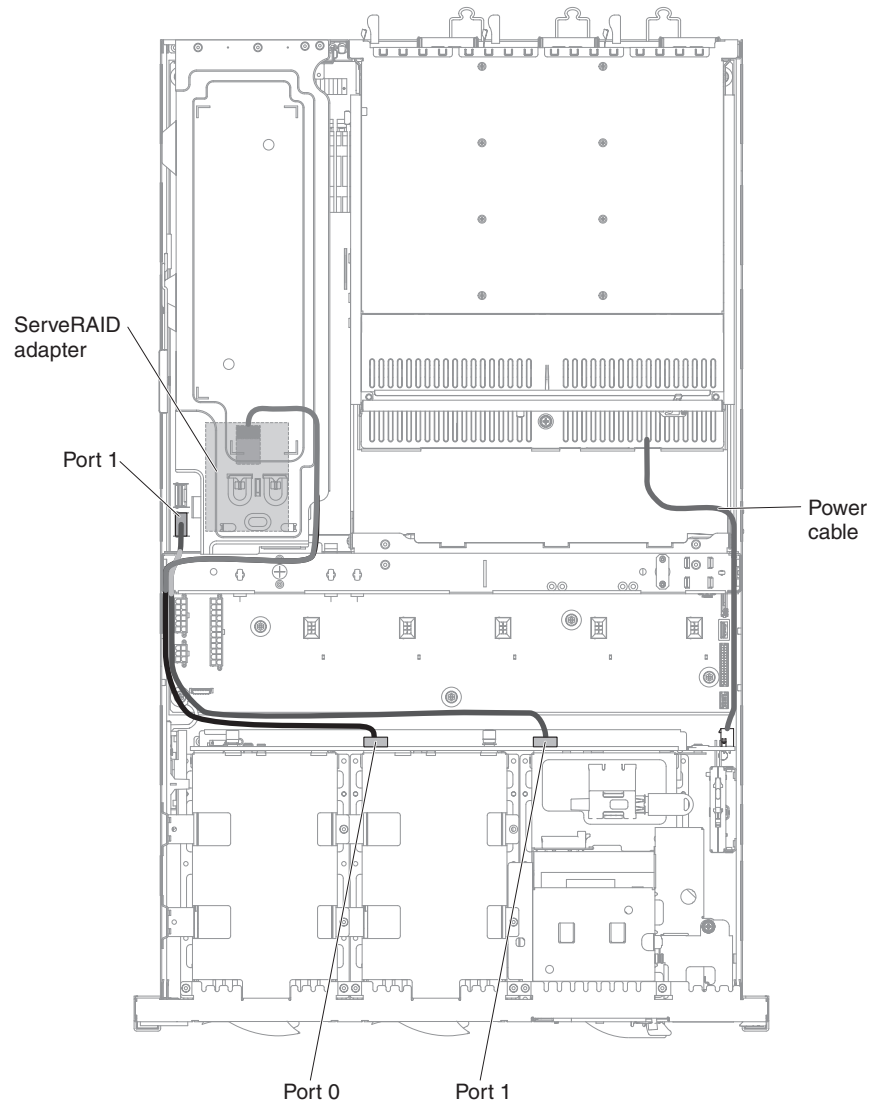

The following illustration shows the internal routing of the simple-swap hard disk drive backplate signal cables to the connectors on the system board.

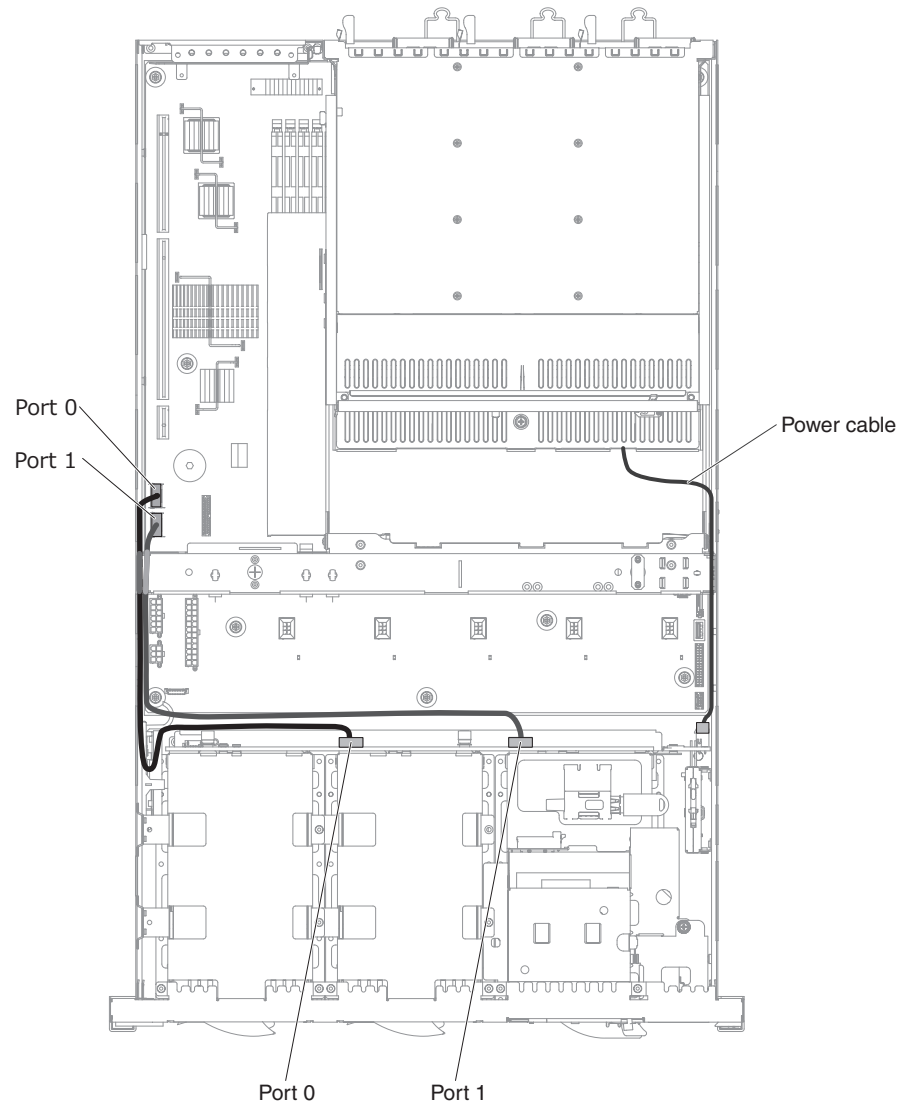

DVD drive cable connection

The following illustration shows the internal routing and connectors of the DVD cable.

Attention: To disconnect the DVD cable, you must first press the connector release tab and then disconnect the cable from the connector on the system board. Do not disconnect the cable by using excessive force.

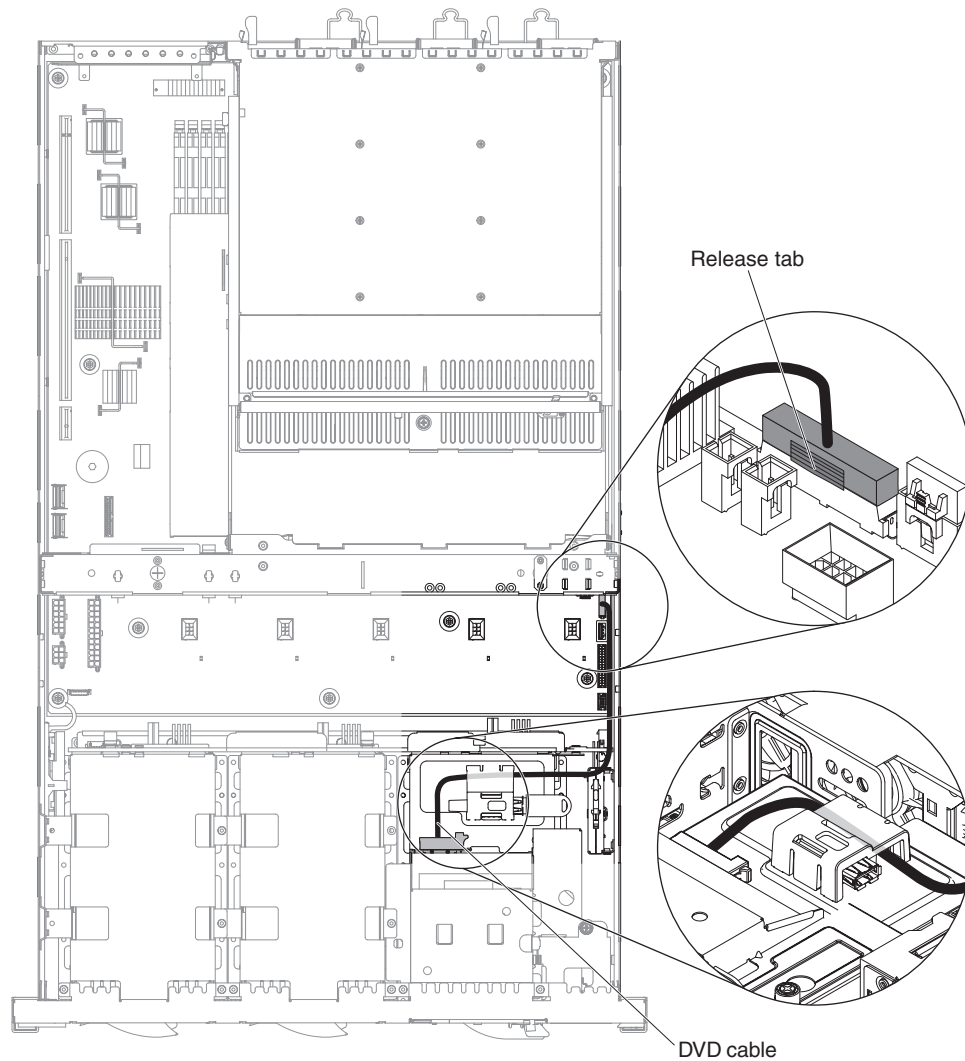

Front USB assembly cable connection

The following illustration shows the routing of the USB hypervisor key signal cable.

Attention: To disconnect the USB hypervisor key signal cable, you must first press the connector release tab and then disconnect the cable from the connector on the system board. Do not disconnect the cable by using excessive force.

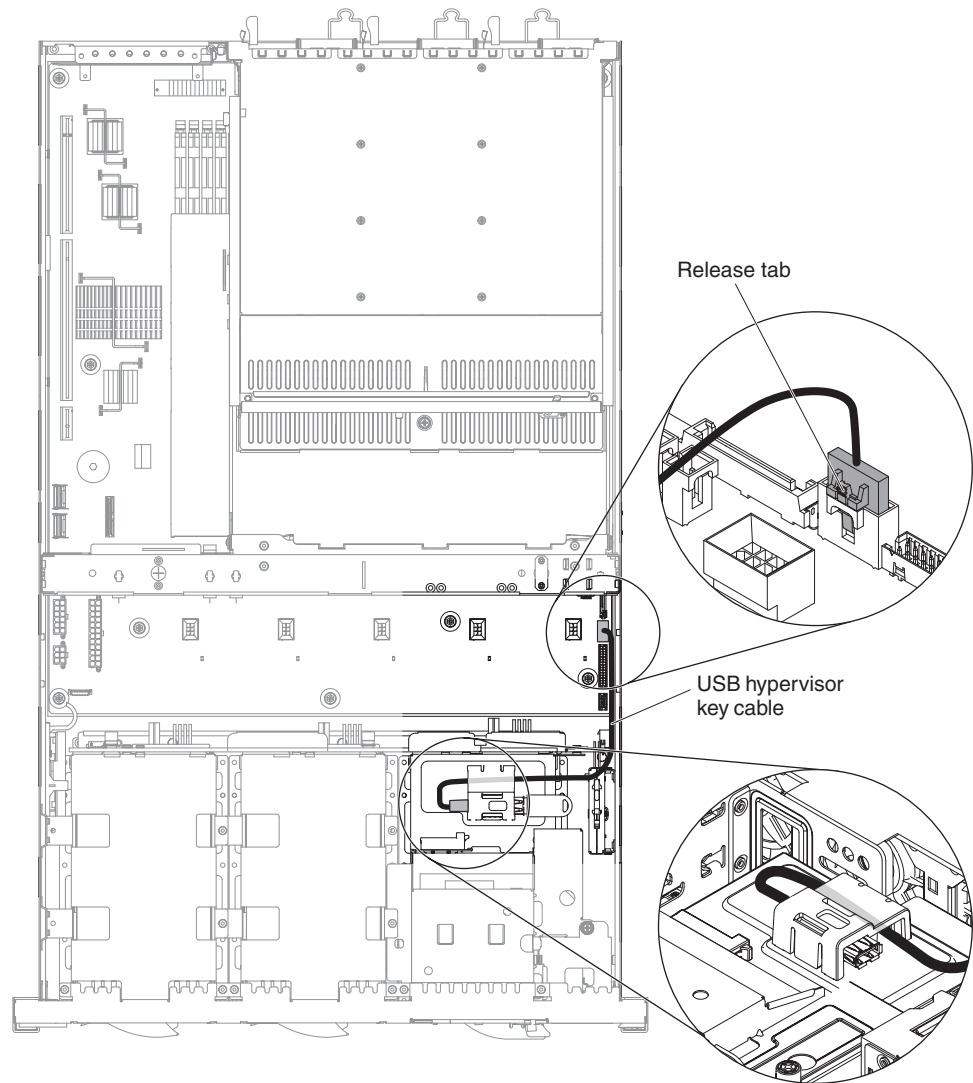

Power-supply distribution board cable connections

The following illustration shows the routing of the power-supply distribution board cables. Secure the power cables with the cable tie and retention clips.

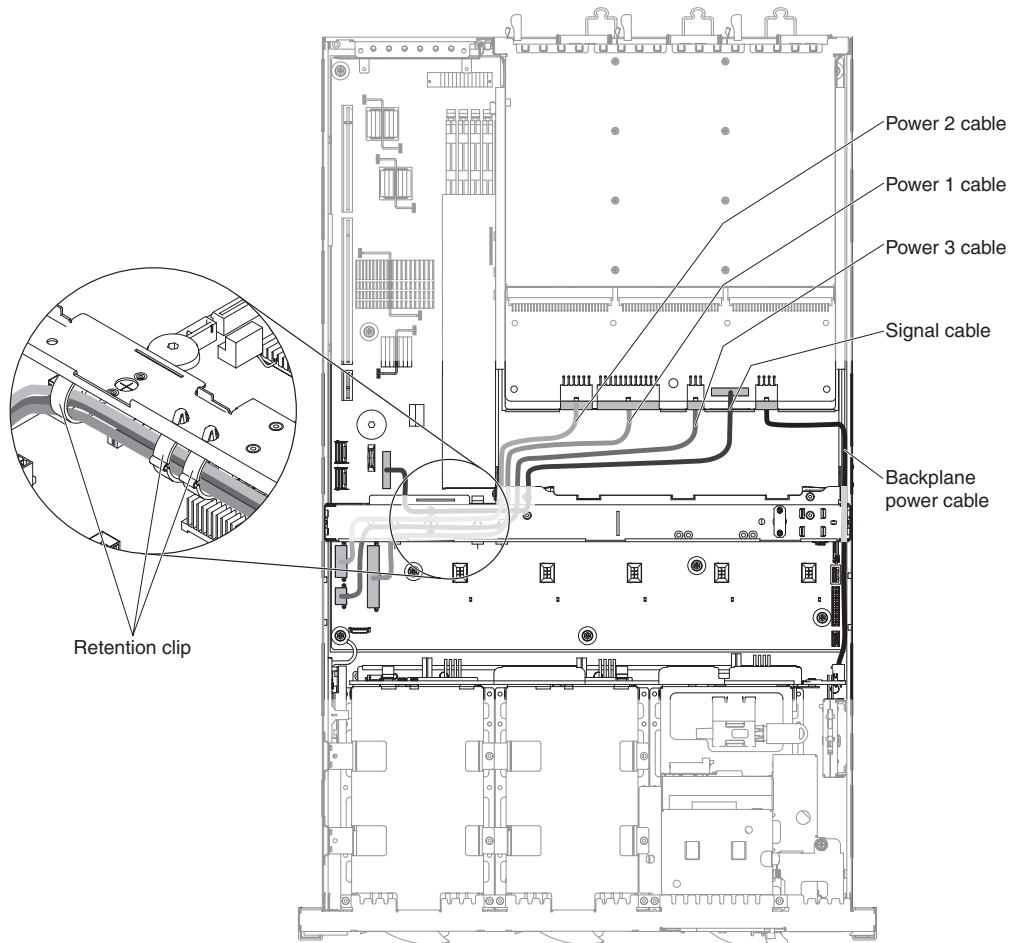

Removing the top cover

Note: Before you install optional hardware devices, make sure that the server is working correctly. Start the server, and make sure that the operating system starts, if an operating system is installed, or that a 19990305 error code is displayed, indicating that an operating system was not found but the server is otherwise working correctly. If the server is not working correctly, see the *Problem Determination and Service Guide* on the IBM *Documentation CD* for information about how to run diagnostics.

Important: The server automatically powers off when the top cover is removed.

To remove the top cover, complete the following steps:

1. Read the safety information that begins on page v and “Installation guidelines” on page 30.
2. Turn off the server and all attached peripheral devices. Disconnect all power cords; then, disconnect all external signal cables from the server.
3. Slide the server out of the rack until the slide rails lock into place.
4. Loosen the two thumbscrews that secure the cover to the chassis.

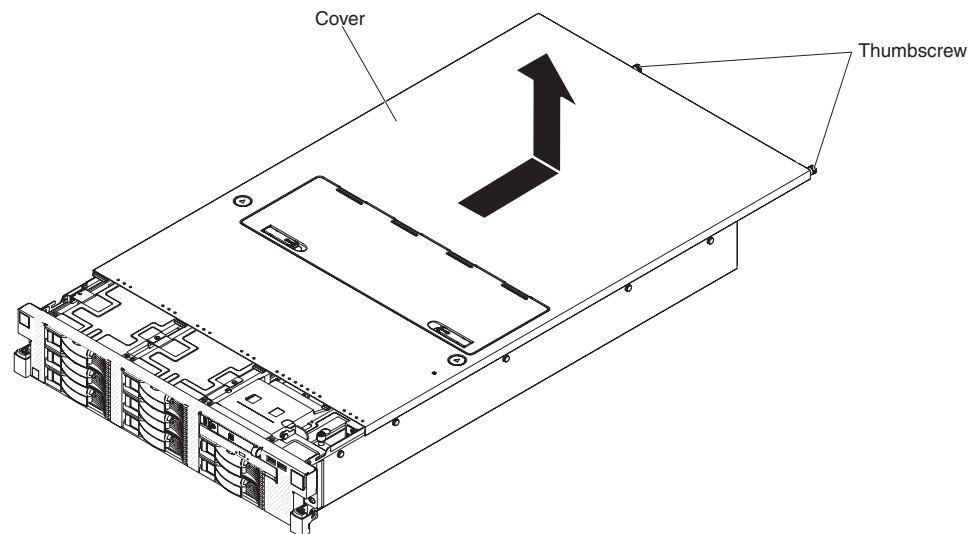

5. Press on the two blue grip points and slide the cover toward the rear; then, lift the cover off the server. Set the cover aside.

Removing the top-cover fan door

Attention: You must turn off the server before you remove or install a non-hot-swap fan.

To remove the top-cover fan door, complete the following steps:

1. Read the safety information that begins on page v and “Installation guidelines” on page 30.
2. If you are removing or replacing a non-hot-swap fan, turn off the server and all attached peripheral devices. Disconnect all power cords; then, disconnect all external signal cables from the server.
3. Slide the server out of the rack until the slide rails lock into place.
4. Press and rotate up the release latches.

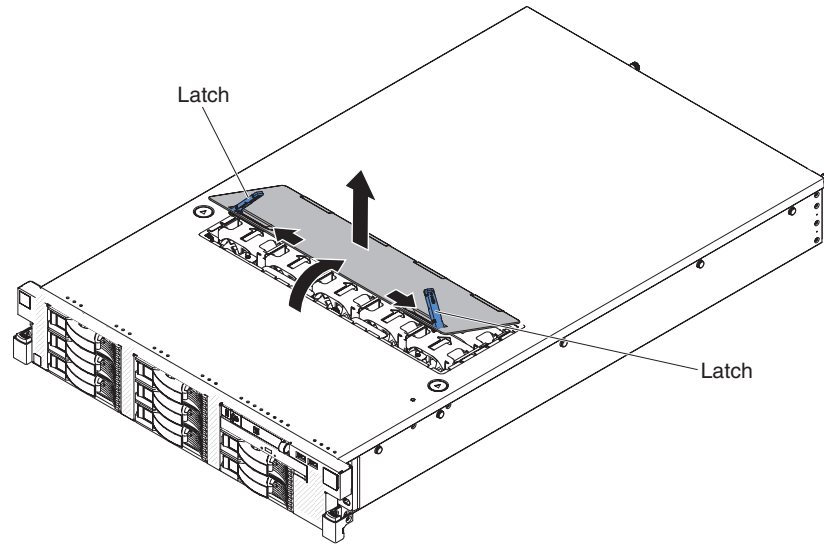

5. Tilt and lift the top-cover fan door from the server.

Removing the PCI riser-card assembly

To remove the PCI riser-card assembly, complete the following steps:

1. Read the safety information that begins on page v and “Installation guidelines” on page 30.
2. Turn off the server and all attached peripheral devices. Disconnect all power cords; then, disconnect all external signal cables from the server.
3. Remove the cover (see “Removing the top cover” on page 39).
4. Pull out the handle to unlatch the PCI riser-card assembly.

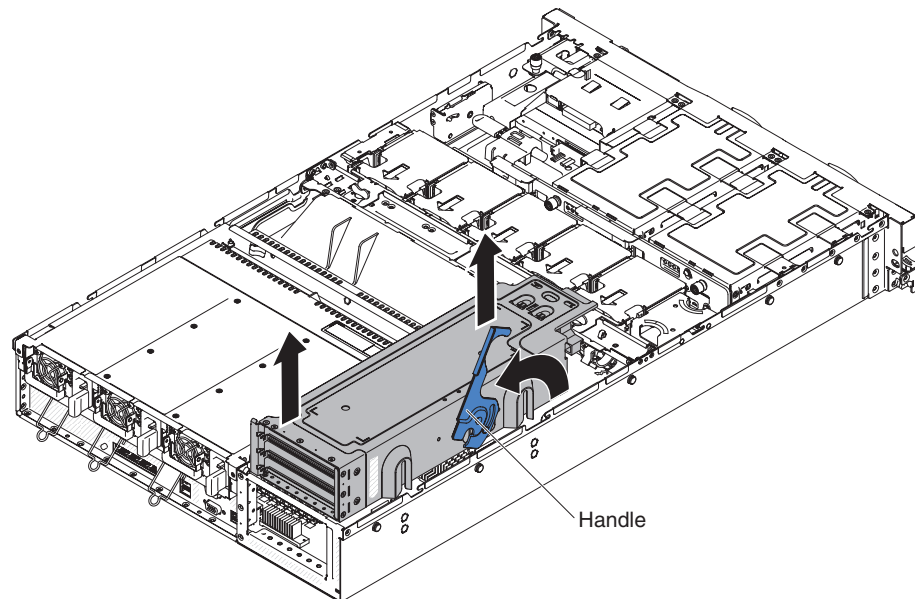

5. Grasp the PCI riser-card assembly at the front grip point and rear edge; then, lift the PCI riser-card assembly to remove it from the server. Place the PCI riser-card assembly on a flat, static-protective surface.

Removing the air baffle

To remove the air baffle, complete the following steps:

1. Read the safety information that begins on page v and “Installation guidelines” on page 30.
2. Turn off the server and all attached peripheral devices. Disconnect all power cords; then, disconnect all external signal cables from the server.
3. Remove the cover (see “Removing the top cover” on page 39).
4. Pull up the handle on the power-supply cage until the handle locks into place.

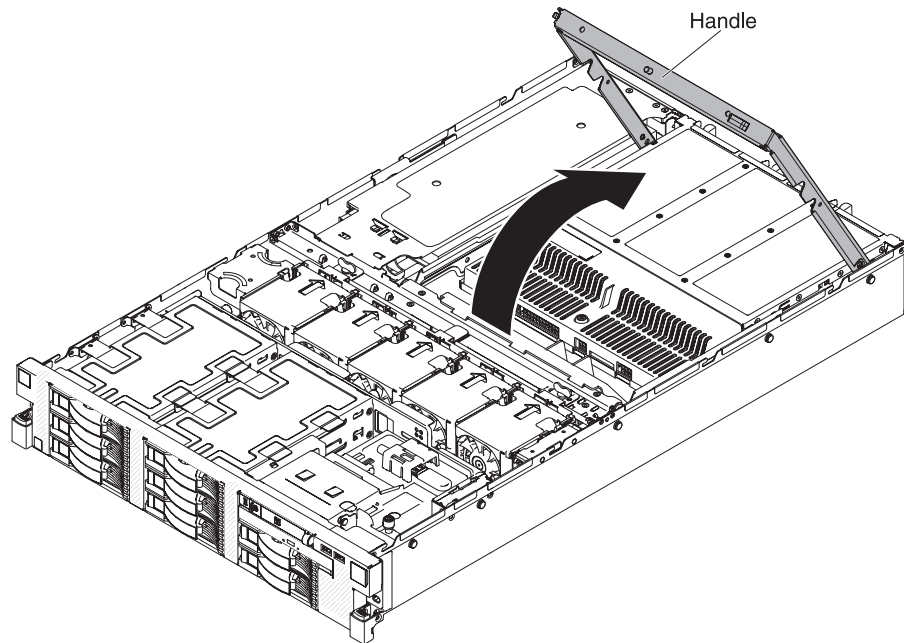

5. Lift and rotate the power-supply cage toward the front of the server; then, align the nailhead on the handle with the hole on the chassis and lower the handle until it clicks into place.

Note: The power-supply cage might be heavy, depending on the number of power supplies that are installed. Support the power-supply cage with both hands while you rotate it into position.

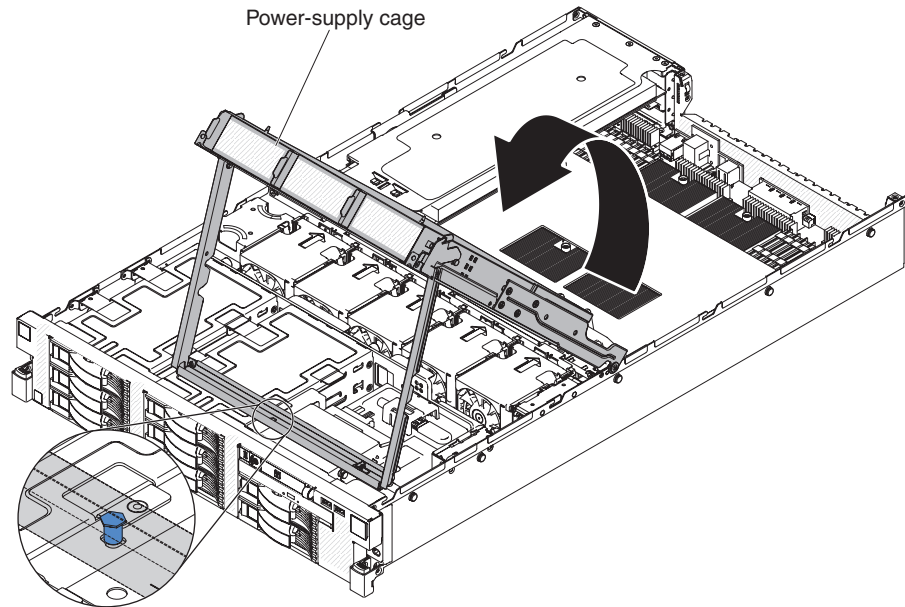

6. Remove the PCI riser-card assembly (see “Removing the PCI riser-card assembly” on page 40).
7. Grasp the air baffle and disengage it from the slots; then, lift the air baffle to remove it from the server.

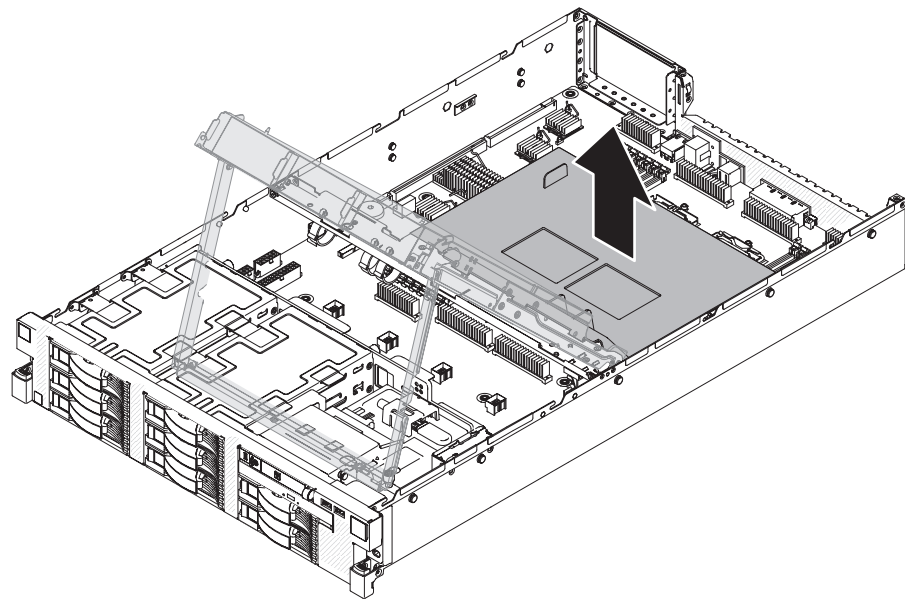

Installing a PCI adapter

The following notes describe the types of adapters that the server supports and other information that you must consider when you install an adapter:

- To confirm that the server supports the adapter that you are installing, see <http://www.ibm.com/systems/info/x86servers/serverproven/compat/us/>.
- Locate the documentation that comes with the adapter and follow those instructions in addition to the instructions in this section. If you must change the switch setting or jumper settings on the adapter, follow the instructions that come with the adapter.

- Avoid touching the components and gold-edge connectors on the adapter.
- If you have not changed the default startup sequence, the server starts the devices in the following order: DVD drive, USB-attached diskette drive, hard disk drive 0, and network devices.

Note: To change the startup sequence, start the Setup utility and select **Start Options** from the main menu. See “Using the Setup utility” on page 78 for details about using the Setup utility.

- The expansion slots in the PCI riser cards accommodate the various form factors of the non-hot-plug adapters as follows:
 - Expansion slot 1: Full-height, full-length
 - Expansion slots 2, 3, and 4: Low-profile, half-length
- You must install a ServeRAID adapter in expansion slot 4 on the PCI riser-card assembly.
- If you are installing a ServeRAID adapter with a battery installed on the adapter, you must install the battery on the remote battery tray.

Attention: Static electricity that is released to internal server components when the server is powered on might cause the server to halt, which might result in the loss of data. To avoid this potential problem, always use an electrostatic-discharge wrist strap or other grounding system when you handle any server components.

To install a PCI adapter, complete the following steps:

1. Read the safety information that begins on page v and “Installation guidelines” on page 30.
2. Turn off the server and peripheral devices, and disconnect the power cords and all external cables.
3. Remove the server cover (see “Removing the top cover” on page 39).
4. Remove the PCI riser-card assembly (see “Removing the PCI riser-card assembly” on page 40).
5. See the documentation that comes with the adapter for instructions for setting jumpers or switches and for cabling.

Note: Route adapter cables before you install the adapter.

6. Determine which PCI expansion slot you will use for the adapter. If you are installing an adapter in expansion slot 1, 2, or 3, remove the expansion-slot cover.

The following illustration shows the locations of the adapter expansion slots from the rear of the server.

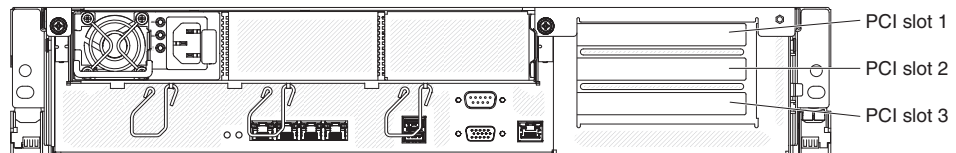

Attention: When you install an adapter, avoid touching the components and gold-edge connectors on the adapter. Make sure that the adapter is correctly seated in the connector. Incorrectly seated adapters might cause damage to the PCI riser card or to the adapter.

7. Touch the static-protective package that contains the adapter to any *unpainted* surface on the outside of the server; then, grasp the adapter by the top edge or upper corners of the adapter and remove it from the package.
8. Align the adapter with the connector on the PCI riser-card assembly.

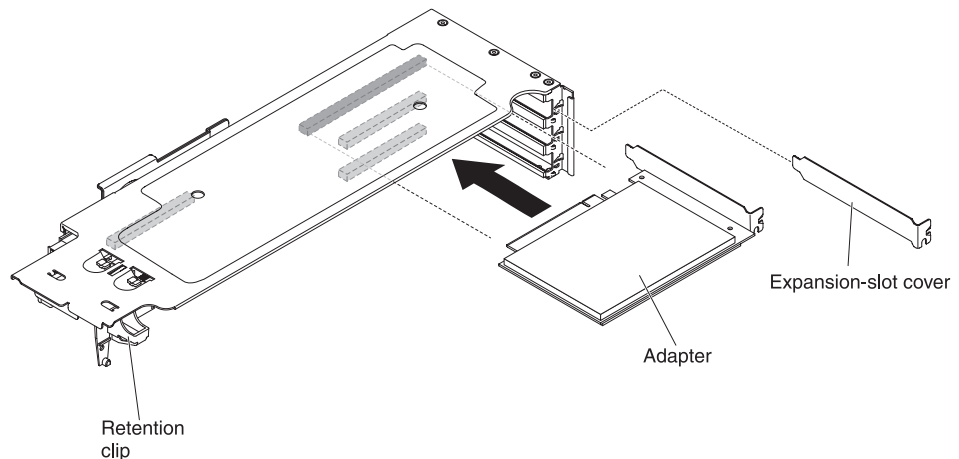

9. Press the adapter *firmly* into the adapter connector. If you install a full-length adapter in slot 1, make sure that the retention clip engages the adapter in place.

Attention: When you install an adapter, avoid touching the components and gold-edge connectors on the adapter. Make sure that the adapter is correctly seated in the connector. Incorrectly seated adapters might cause damage to the PCI riser card or to the adapter.

10. Connect any required cables to the adapter.
11. Install the PCI riser-card assembly (see “Installing the PCI riser-card assembly” on page 70).

If you have other devices to install or remove, do so now. Otherwise, go to “Completing the installation” on page 70.

Installing a ServeRAID SAS/SATA controller

Note: You must install a ServeRAID controller in expansion slot 4 on the PCI riser-card assembly.

To install a ServeRAID controller, complete the following steps:

1. Read the safety information that begins on page v and “Installation guidelines” on page 30.
2. Turn off the server and peripheral devices, and disconnect the power cords and all external cables.
3. Remove the server cover (see “Removing the top cover” on page 39).
4. Remove the PCI riser-card assembly (see “Removing the PCI riser-card assembly” on page 40).
5. Touch the static-protective package that contains the new ServeRAID controller to any *unpainted* metal surface on the server. Then, remove the ServeRAID controller from the package.
6. If you are installing a new or replacement ServeRAID controller that uses a battery, complete the following steps:
 - a. Remove the battery from the ServeRAID controller package or the battery package.
 - b. Install the battery and connect the battery to the ServeRAID controller as instructed in the documentation that comes with the ServeRAID controller or the battery, or see “Installing a ServeRAID controller battery on the remote battery tray” on page 47.
7. Install the ServeRAID controller.

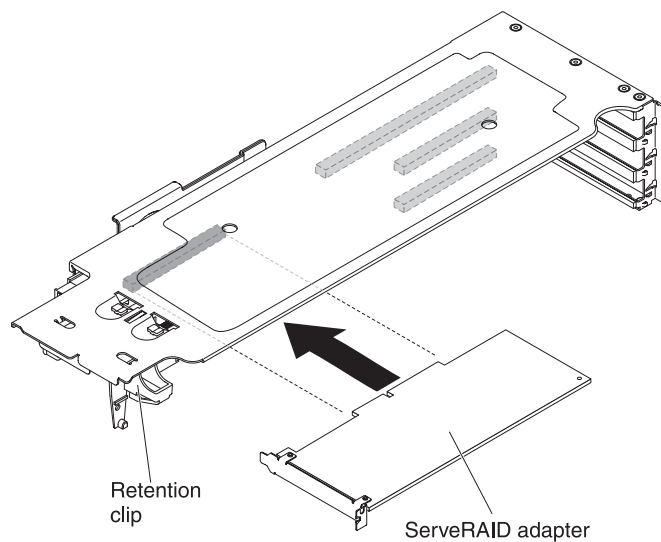

- a. Install the 2U low-profile bracket to the ServeRAID controller (if it is not installed).

- b. Align the ServeRAID controller with expansion slot 4 on the PCI riser-card assembly and the guide on the retention tab.
 - c. Firmly press the ServeRAID controller into the connector. Make sure that the retention clip securely engages the bracket on the ServeRAID controller.
8. Route the signal cables and connect the signal cables to the ServeRAID controller (see “Internal cable routing and connectors” on page 33).

If you have other devices to install or remove, do so now. Otherwise, go to “Completing the installation” on page 70.

Notes:

1. When you restart the server for the first time after you install a ServeRAID controller with a battery, the monitor screen remains blank while the controller initializes the battery. This might take a few minutes, after which the startup process continues. This is a one-time occurrence.
Important: You must allow the initialization process to be completed. If you do not, the battery pack will not work, and the server might not start.
The battery comes partially charged, at 30% or less of capacity. Run the server for 4 to 6 hours to fully charge the controller battery. The LED just above the battery on the controller remains lit until the battery is fully charged.
Until the battery is fully charged, the controller firmware sets the controller cache to write-through mode; after the battery is fully charged, the controller firmware re-enables write-back mode.
2. When you restart the server, you are given the opportunity to import the existing RAID configuration to the new ServeRAID controller.
3. Before you install a UEFI operating system on a server with a ServeRAID controller, you must select **UEFI driver for Launch storage OpROM** in the Setup utility (see “Typical operating-system installation” on page 84).

Installing a ServeRAID controller battery on the remote battery tray

The Intelligent Battery Backup Unit (iBBU) is an optional battery for the ServeRAID adapter. It is referred to as the *battery* throughout this section. You must install the battery at a distance from the ServeRAID controller to avoid overheating.

To install a ServeRAID controller battery on the remote battery tray, complete the following steps:

1. Read the safety information that begins on page v and “Installation guidelines” on page 30.
2. Turn off the server and peripheral devices, and disconnect the power cords and all external cables.
3. Remove the server cover (see “Removing the top cover” on page 39).
4. Remove the PCI riser-card assembly (see “Removing the PCI riser-card assembly” on page 40).
5. If a battery and battery carrier are attached to the ServeRAID controller, remove the three screws that secure the battery carrier to the ServeRAID controller. Set the battery and battery carrier aside.

Note: The illustrations in this document might differ slightly from your hardware.

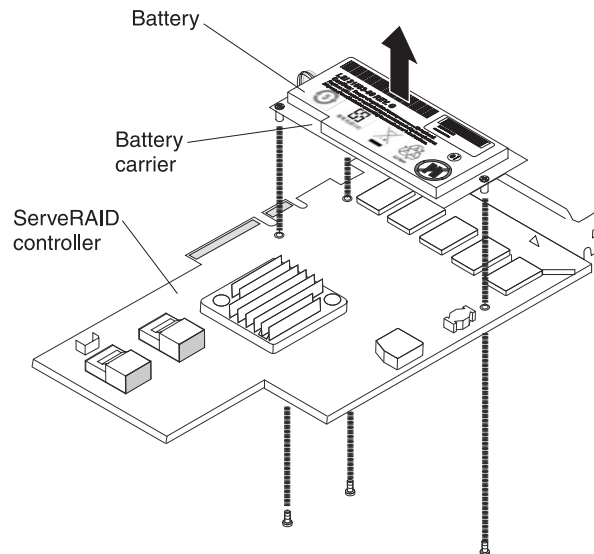

6. Install the interposer card on the interposer card connector on the ServeRAID controller:
 - a. Remove the interposer card and the loose screws from the bag.
 - b. Rotate the standoff so that it aligns with the hole in the ServeRAID controller, and position the interposer card connector over the ServeRAID controller connector.

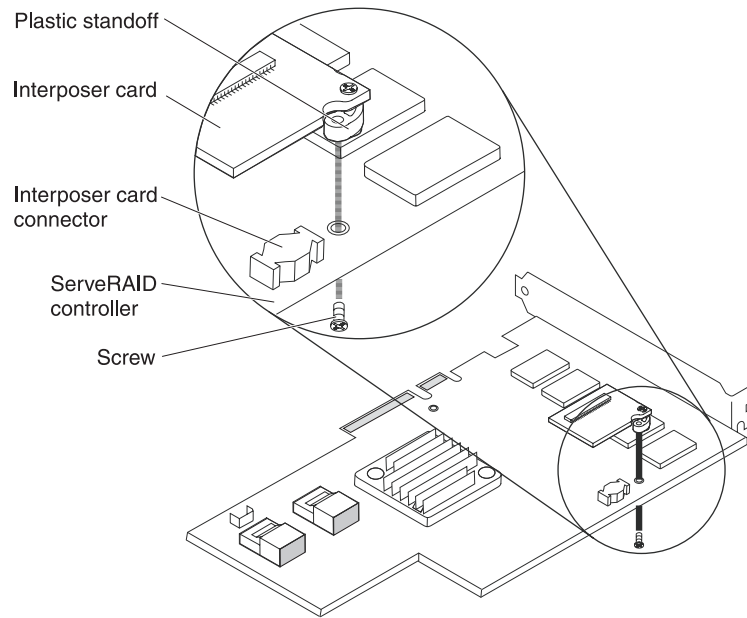

- c. Press the interposer card down onto the interposer card connector so that the interposer card is secured.
 - d. From the other side of the ServeRAID controller, insert and tighten the screws to secure the interposer card to the ServeRAID controller.
7. Install the battery on the remote battery tray:
- a. Pull the loop on the remote battery tray away from the chassis; then, slide the tray toward the rear of the server to remove the tray from the side of the chassis.

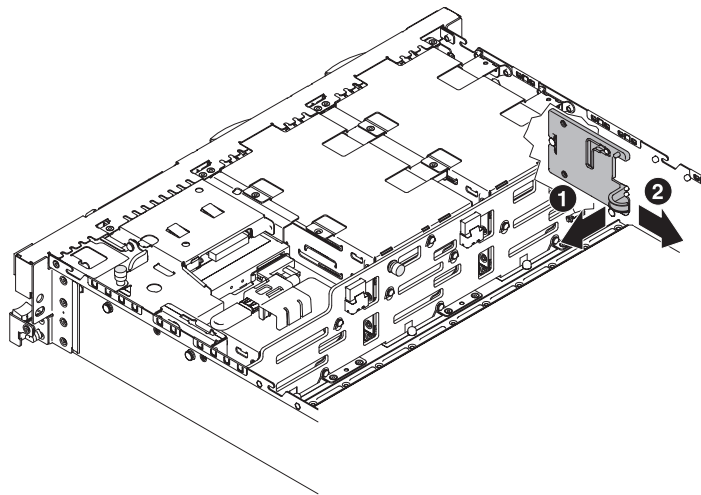

- b. On the remote battery tray, find the pattern of recessed rings that matches the pins on the battery carrier.

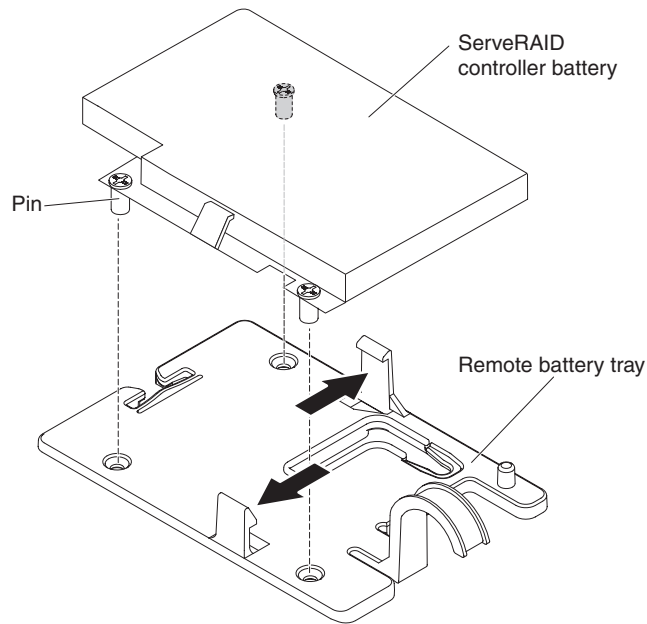

- c. Press the pins into the rings on the remote battery tray. Make sure the two retention clips secure the battery and battery carrier on the remote battery tray.
8. Connect the remote battery cable to the battery carrier.
Attention: To avoid damage to the hardware, be sure to align the black dot on the cable connector with the black dot on the connector on the interposer card. *Do not force the remote battery cable into the connector.*
9. Route the remote battery cable through the cage hole on the chassis. You may store the excess battery cable in the space between the hard drive cage and the chassis.
Attention: Make sure that the cable is not pinched and does not cover any connectors or obstruct any components on the system board.

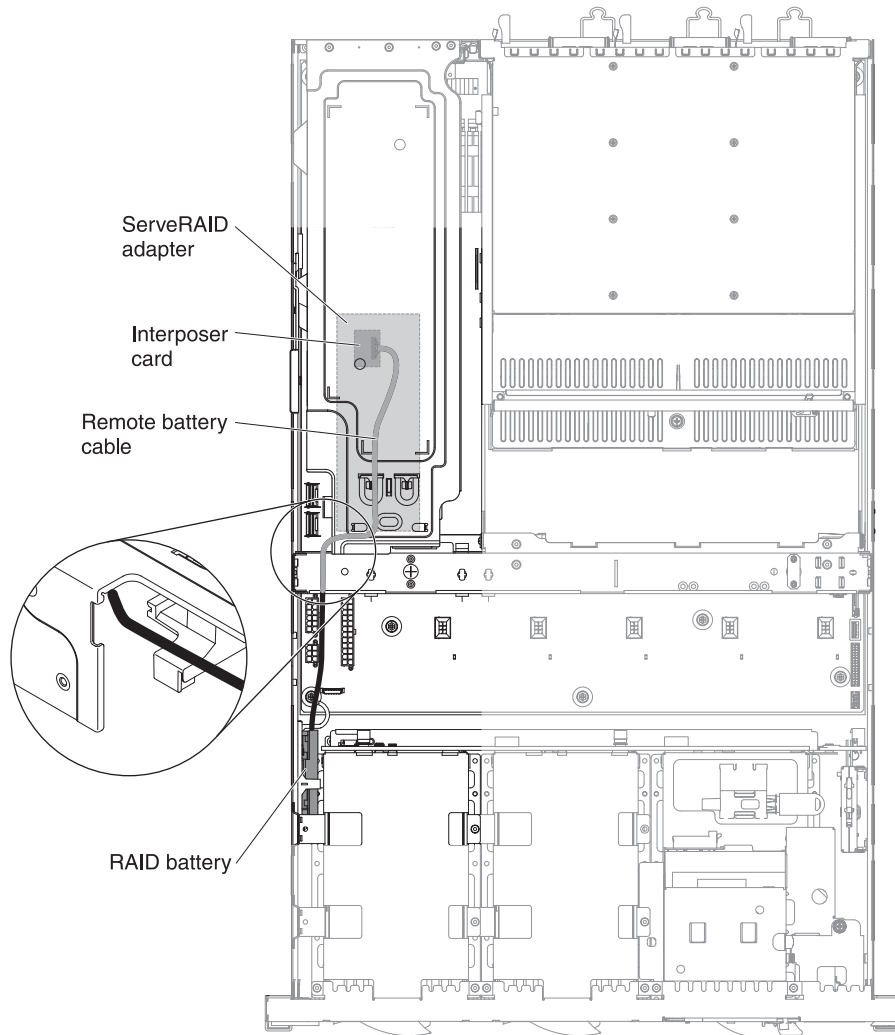

10. Connect the other end of the remote battery cable to the interposer card on the ServeRAID controller. Route the remote battery cable through the opening on the PCI riser-card assembly.

Attention: To avoid damage to the hardware, be sure to align the black dot on the cable connector with the black dot on the connector on the interposer card. *Do not force the remote battery cable into the connector.*

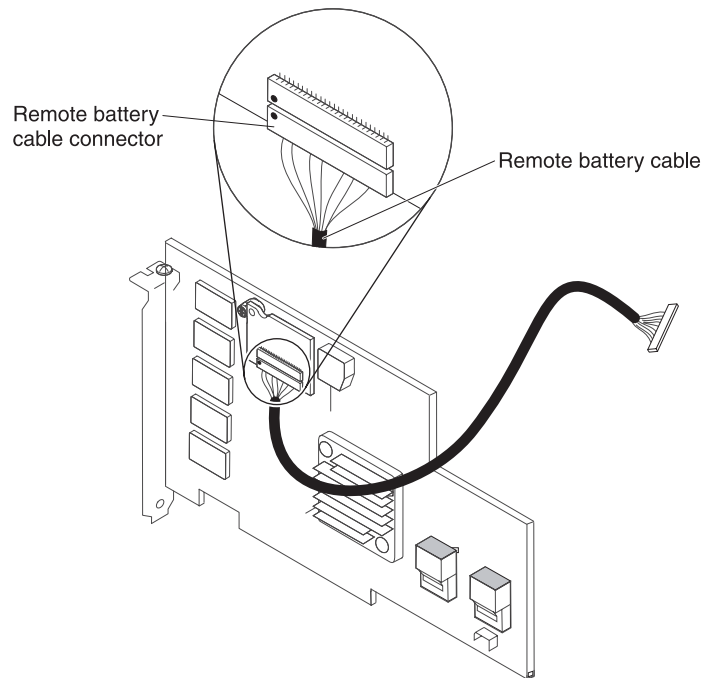

11. Align the slot on the remote battery tray with the nailhead on the side of the chassis; then, push the remote battery tray toward the front of the server until the nailhead slides into the slot to secure the remote battery tray on the chassis.

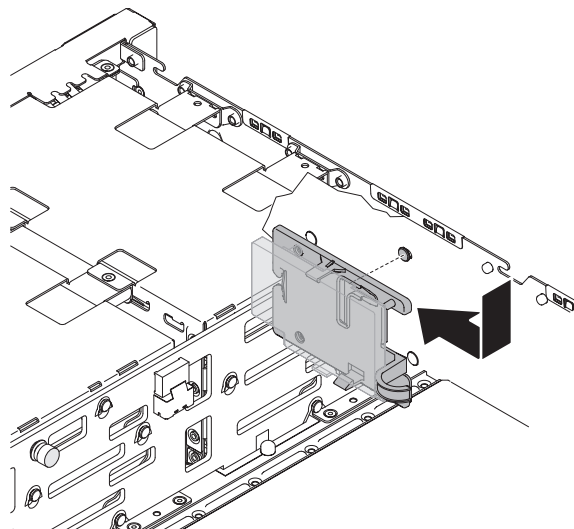

12. Install the ServeRAID controller on the PCI riser-card assembly (see “Installing a ServeRAID SAS/SATA controller” on page 45).

If you have other devices to install or remove, do so now. Otherwise, go to “Completing the installation” on page 70.

Notes:

1. When you restart the server for the first time after you install a ServeRAID controller with a battery, the monitor screen remains blank while the controller initializes the battery. This might take a few minutes, after which the startup process continues. This is a one-time occurrence.

Important: You must allow the initialization process to be completed. If you do not, the battery pack will not work, and the server might not start.

The battery comes partially charged, at 30% or less of capacity. Run the server for 4 to 6 hours to fully charge the controller battery. The LED just above the battery on the controller remains lit until the battery is fully charged.

Until the battery is fully charged, the controller firmware sets the controller cache to write-through mode; after the battery is fully charged, the controller firmware re-enables write-back mode.

2. When you restart the server, you are given the opportunity to import the existing RAID configuration to the new ServeRAID controller.

Installing an optional ServeRAID controller advanced feature key

To install an optional ServeRAID controller advanced feature key, complete the following steps:

1. Read the safety information that begins on page v and “Installation guidelines” on page 30.
2. Turn off the server and peripheral devices, and disconnect the power cords and all external cables.
3. Remove the server cover (see “Removing the top cover” on page 39).
4. Remove the PCI riser-card assembly (see “Removing the PCI riser-card assembly” on page 40).
5. Align the upgrade key with the connector on the ServeRAID controller and push it into the connector until it is firmly seated.

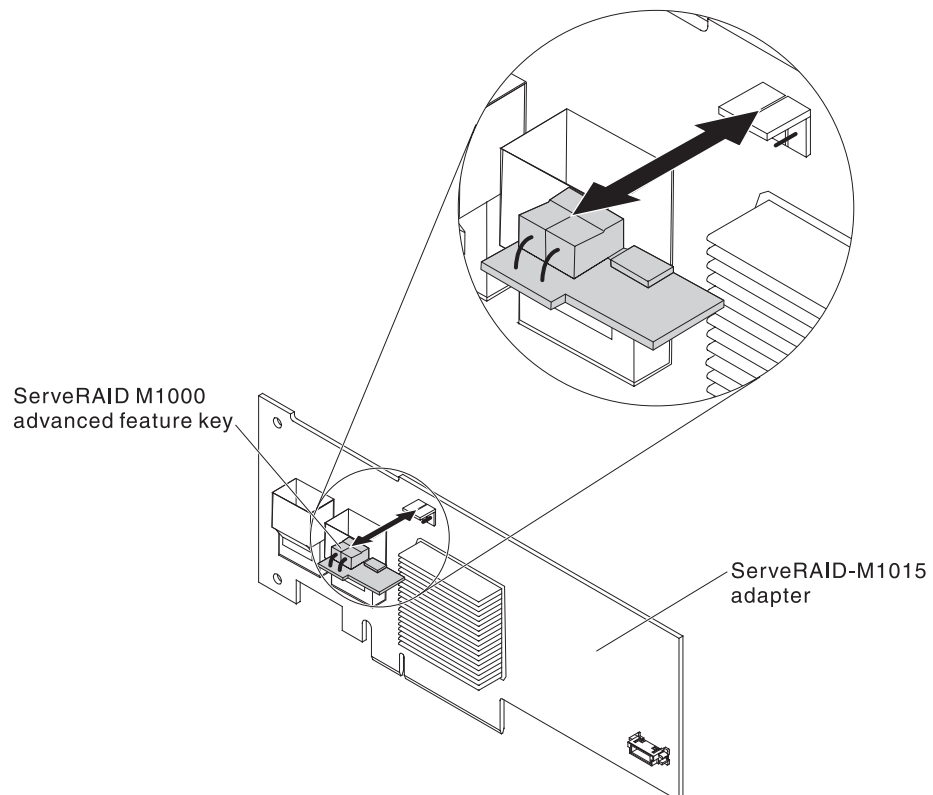

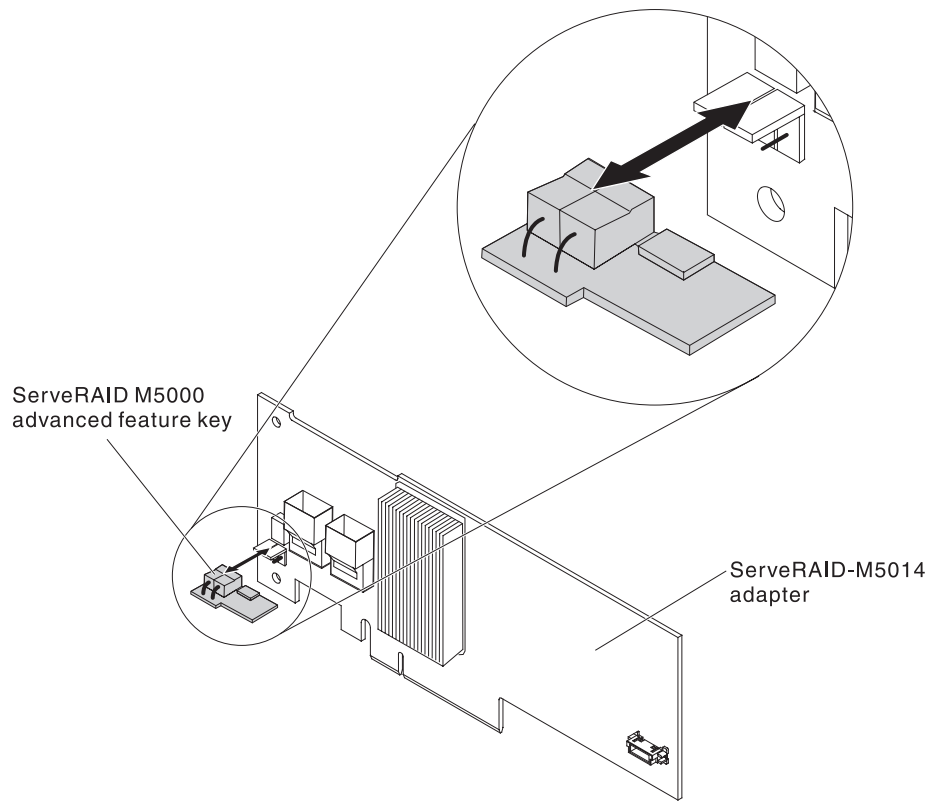

If you have other devices to install or remove, do so now. Otherwise, go to “Completing the installation” on page 70.

Installing a hot-swap power supply

The following notes describe the type of power supply that the server supports and other information that you must consider when you install a power supply:

- The server comes standard with one 1100-watt hot-swap power supply for a two-microprocessor configuration or two 1100-watt hot-swap power supplies for a four-microprocessor configuration.
- If the maximum load on the server is more than 935 watts or if a problem occurs with one of the power supplies, the redundant power supply can meet the power requirements.

To provide redundant power capabilities in the server:

- install two power supplies in a server with two microprocessors or more microprocessors (less than 80W).
- install three power supplies in a server with four microprocessors (greater than 80W).

Notes:

1. In a server with two-microprocessor configuration, two power supplies must be installed in the server for either power supply to be considered hot-swap. If the server comes with four microprocessors, three power supplies must be installed in the server for a power supply to be considered hot-swap.
2. The IBM Power Configurator detects your server power consumption and helps you determine whether an additional power supply is required before you install more components in the server. You can download a free copy of

the IBM Power Configurator from the IBM website at <http://www-03.ibm.com/systems/bladecenter/resources/powerconfig.html>.

- These power supplies are designed for parallel operation. In the event of a power-supply failure, the redundant power supply continues to power the system. The server supports a maximum of three power supplies.
- The server can run fully configured with:
 - one power supply when two microprocessors or four 80W microprocessors are installed.
 - three power supply when four microprocessors (more than 80W) are installed.
 -
- To confirm that the server supports the power supply that you are installing, see <http://www.ibm.com/systems/info/x86servers/serverproven/compat/us/>.

To install an additional hot-swap power supply, complete the following steps:

1. Read the safety information that begins on page v and “Installation guidelines” on page 30.
2. Grasp the side clip and pull to remove the power-supply filler panel from the empty power-supply bay. Save the power-supply filler panel in case you remove the power supply at a later time.

Important: During normal operation, each power-supply bay must contain either a power supply or power-supply filler panel for proper cooling.

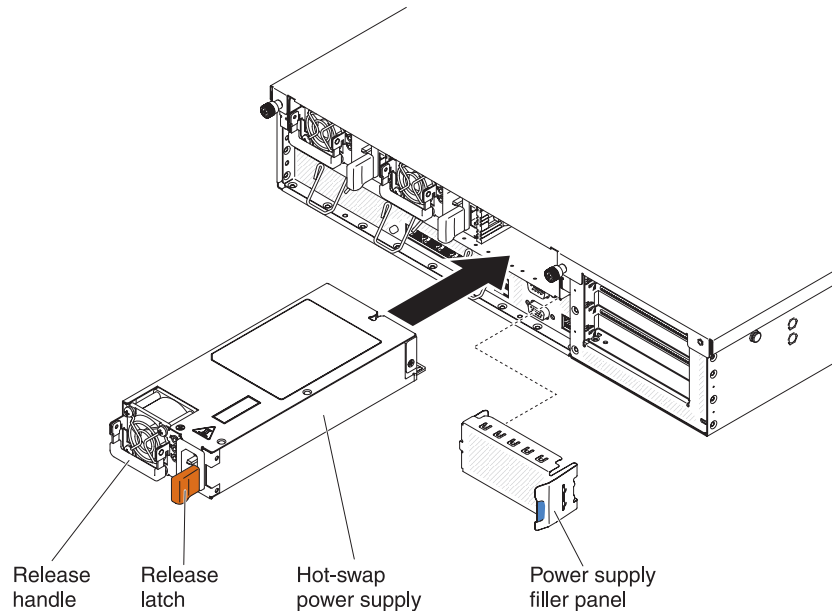

3. Slide the ac power supply into the bay until the release latch clicks into place.
4. Connect one end of the power cord for the new power supply into the ac connector on the back of the power supply; then, connect the other end of the power cord into a properly grounded electrical outlet.

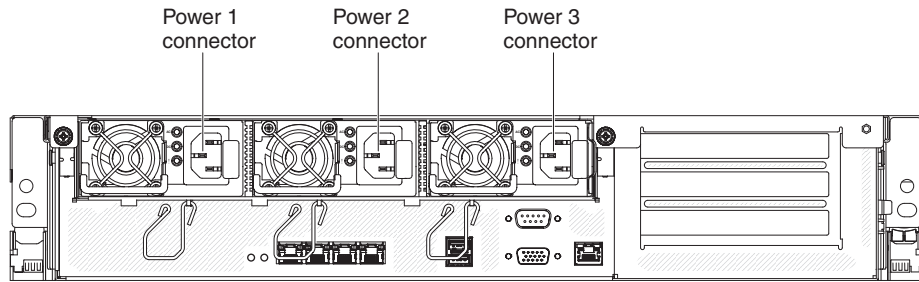

Note: If you disconnect the ac power cord, wait for 20 seconds before you reconnect the ac power cord and start the server. Avoid disconnecting and reconnecting the ac power cord repeatedly.

5. Route the power cord through the cable retention hook on the rear of the server so that it does not accidentally become disconnected.
6. If the server is turned off, turn on the server.
7. Make sure that the ac power LED on the power supply is lit, indicating that the power supply is operating correctly. If the server is turned on, make sure that the dc power LED on the power supply is lit also.
8. (IBM Business Partners only) Restart the server. Confirm that it starts correctly and recognizes the newly installed devices, and make sure that no error LEDs are lit.
9. (IBM Business Partners only) Complete the additional steps in “Instructions for IBM Business Partners” on page 21.

Installing a hot-swap hard disk drive

The following notes describe the types of hot-swap hard disk drives that the server supports and other information that you must consider when you install a hot-swap hard disk drive:

- To confirm that the server supports the hard disk drive that you are installing, see <http://www.ibm.com/systems/info/x86servers/serverproven/compat/us/>.
- The server supports up to eight 3.5-inch hot-swap hard disk drives.
- Start installing the hard disk drives from bay 0.
- If the server will be configured for RAID operation, see the documentation that comes with the controller for instructions for installing a hard disk drive.
- All hot-swap drives in the server should have the same throughput speed rating; using drives with different speed ratings might cause all drives to operate at the lowest throughput speed.
- To minimize the possibility of damage to the hard disk drives when you install the server in a rack configuration, install the server in the rack before you install the hard disk drives.
- You do not have to turn off the server to install hot-swap drives in the hot-swap drive bays. However, you must turn off the server when you perform any steps that involve installing or removing cables.

To install a hot-swap hard disk drive, complete the following steps:

1. Read the safety information that begins on page v and “Installation guidelines” on page 30.
2. Remove the filler panel from one of the empty hot-swap bays.

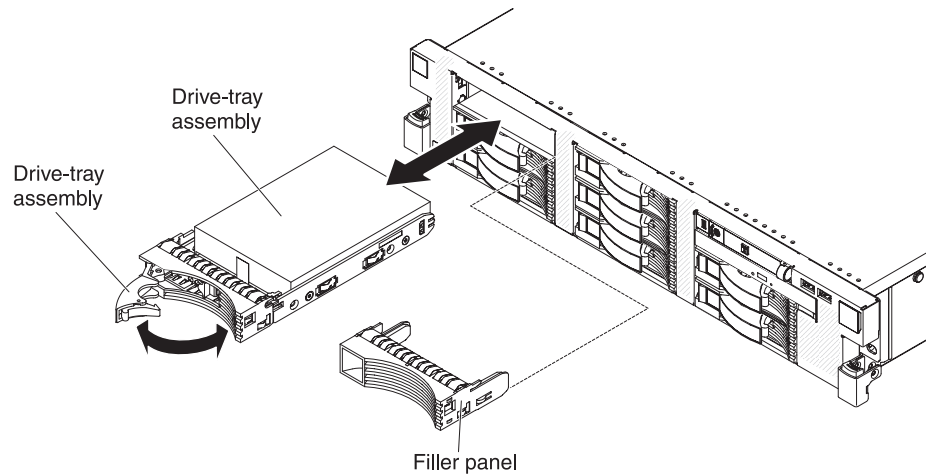

3. Touch the static-protective package that contains the hard disk drive to any *unpainted* surface on the outside of the server; then, remove the hard disk drive from the package.
4. Make sure that the drive handle is open; then, install the hard disk drive into the hot-swap bay.
5. If the system is turned on, check the hard disk drive status LED to verify that the hard disk drive is operating correctly.

After you install a hard disk drive, the green activity LED flashes as the disk spins up. The amber LED turns off after approximately 1 minute. If the new drive starts to rebuild, the amber LED flashes slowly and the green activity LED remains lit during the rebuild process. If the amber LED remains lit, see the *Problem Determination and Service Guide* on the IBM Documentation CD for hard disk drive problem solutions.

6. (IBM Business Partners only) Restart the server. Confirm that it starts correctly and recognizes the newly installed devices, and make sure that no error LEDs are lit.
7. (IBM Business Partners only) Complete the additional steps in “Instructions for IBM Business Partners” on page 21.

Notes:

1. You might have to reconfigure the disk arrays after you install hard disk drives. See the RAID documentation on the IBM *ServeRAID Support* CD for information about RAID controllers.
2. If you install more than one bootable hard disk drive in the server, you must use the LSI Configuration Utility program to select the hard disk drive to boot from. For information on LSI Configuration Utility program, see the documentation that comes with your ServeRAID controller.

Installing a simple-swap hard disk drive

The following notes describe the types of simple-swap hard disk drives that the server supports and other information that you must consider when you install a simple-swap hard disk drive:

- To confirm that the server supports the hard disk drive that you are installing, see <http://www.ibm.com/systems/info/x86servers/serverproven/compat/us/>.
- The server supports up to six 3.5-inch simple-swap hard disk drives if you install an optional tape drive.
- Start installing the hard disk drives from bay 0.

- If the server will be configured for RAID operation, see the documentation that comes with the controller for instructions for installing a hard disk drive.
- All simple-swap drives in the server should have the same throughput speed rating; using drives with different speed ratings might cause all drives to operate at the lowest throughput speed.
- To minimize the possibility of damage to the hard disk drives when you install the server in a rack configuration, install the server in the rack before you install the hard disk drives.

To install a simple-swap hard disk drive, complete the following steps:

1. Read the safety information that begins on page v and “Installation guidelines” on page 30.
2. Turn off the server and peripheral devices, and disconnect the power cords and all external cables.
3. Remove the filler panel from one of the empty drive bays.

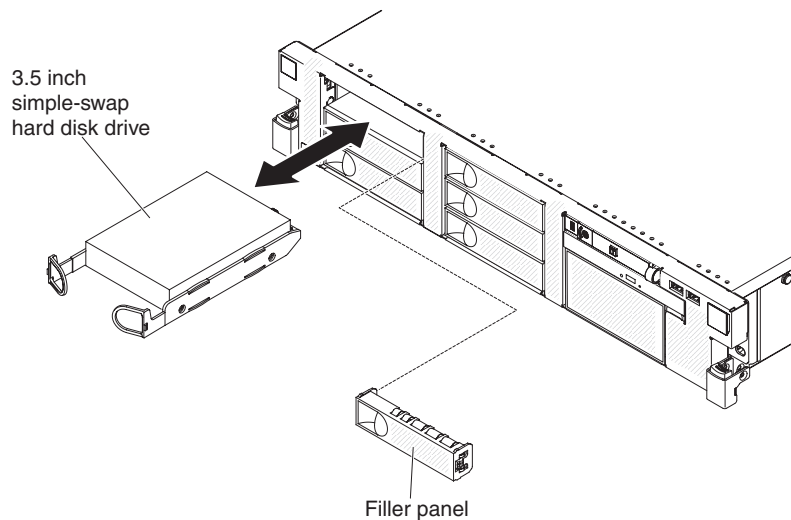

4. Touch the static-protective package that contains the hard disk drive to any *unpainted* surface on the outside of the server; then, remove the hard disk drive from the package.
5. Pull the round blue loops of the hard disk drive toward each other; then, carefully slide the drive into the drive bay until it stops, and release the loops.
6. (IBM Business Partners only) Restart the server. Confirm that it starts correctly and recognizes the newly installed devices, and make sure that no error LEDs are lit.
7. (IBM Business Partners only) Complete the additional steps in “Instructions for IBM Business Partners” on page 21.

Notes:

1. You might have to reconfigure the disk arrays after you install hard disk drives. See the RAID documentation on the IBM *ServeRAID Support* CD for information about RAID controllers.
2. If you install more than one bootable hard disk drive in the server, you must use the LSI Configuration Utility program to select the hard disk drive to boot from. For information on LSI Configuration Utility program, see the documentation that comes with your ServeRAID controller.

Installing an optional DVD drive

To install an optional DVD drive, complete the following steps:

1. Read the safety information that begins on page v and “Installation guidelines” on page 30.
2. Turn off the server and peripheral devices, and disconnect the power cord and all external cables.
3. Remove the DVD drive filler panel if it is installed. Press the release latch on the front of the server and pull out the release latch to remove the DVD drive filler slightly out of the server; then, remove the DVD drive filler completely out of the drive bay.

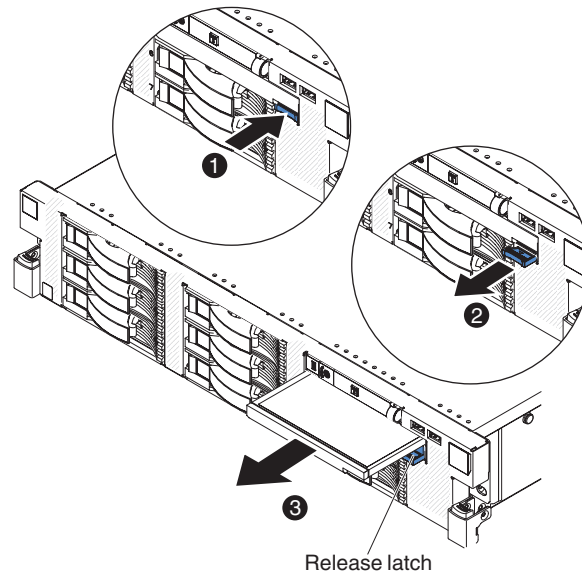

4. Slide the DVD drive into the server until it clicks into place.

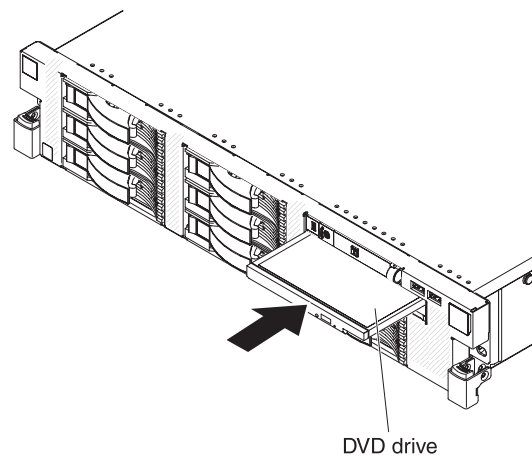

5. Press in the release latch to secure the DVD drive in place.

If you have other devices to install or remove, do so now. Otherwise, go to “Completing the installation” on page 70.

Installing an optional tape drive enablement kit and tape drive

The IBM System x37550 M3 tape drive enablement kit is used to install an optional tape drive in simple-swap models of the server. See <http://www.ibm.com/servers/eserver/serverproven/compat/us/> for a list of supported optional devices. To order a tape drive enablement kit, contact your IBM marketing representative or authorized reseller. The IBM System x3755 M3 tape drive enablement kit is compatible only with the following tape drive:

- IBM DDS Generation 5 (DDS5) SATA tape drive

The IBM System x3755 M3 tape drive enablement kit contains the following components:

- One tape drive tray (with attached cable)
- Bezel(s)

Note: The optional tape drive is supported only on simple-swap models of the server.

To install an optional tape drive, complete the following steps:

1. Read the safety information that begins on page v and “Installation guidelines” on page 30.
2. Turn off the server and peripheral devices, and disconnect the power cord and all external cables.
3. If the tape drive comes with a metal spacer attached, remove the spacer before you install the tape drive on the tray.
4. Prepare the drive according to the instructions that come with the drive, setting any switches or jumpers.
5. Install the drive tray on the new tape drive as shown and tighten the four screws to secure the tape drive to the bottom tray.

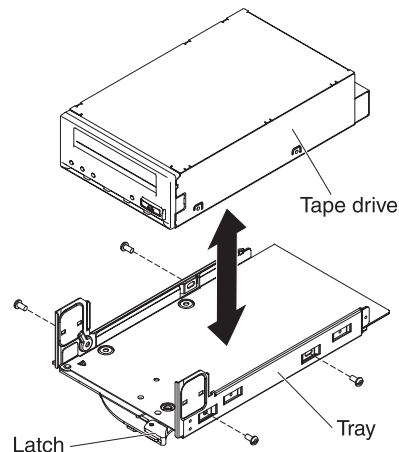

6. Align the tabs on the tape drive bezel with the holes on the tape drive and insert the tabs until they snap into place.

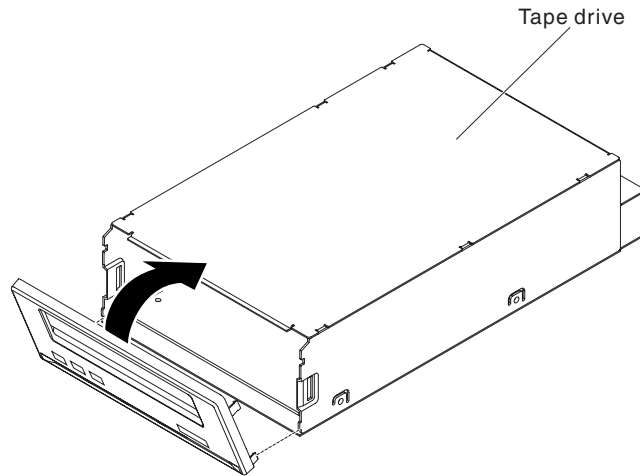

7. Connect the tape drive cable to the tape drive and rotate the top of the bezel toward the tape drive until the retention clips on the side of the bezel securely engages the tape drive

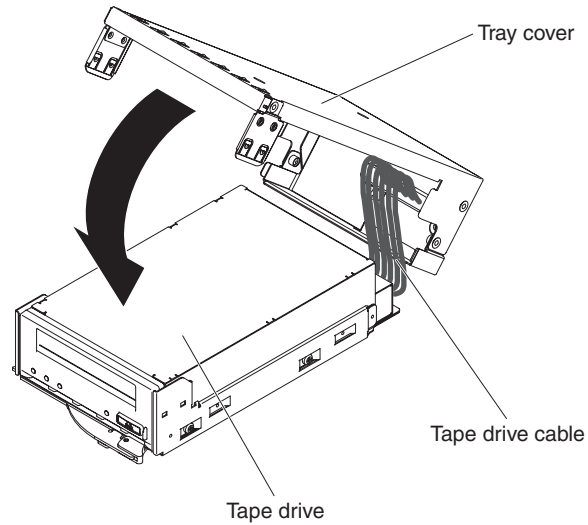

8. Remove the drive filler panel from drive bays 6 and 7.
9. Slide the tape-drive assembly into the server.

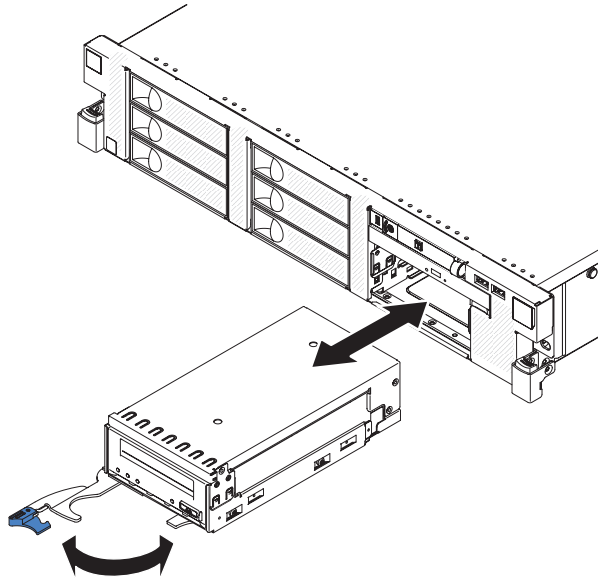

10. Push the tray handle to the closed (locked) position.

If you have other devices to install or remove, do so now. Otherwise, go to “Completing the installation” on page 70.

Installing an internal flash memory

Attention: Before you install an internal flash memory for VMware, make sure you install at least two DIMMs for each microprocessor in the server.

The server supports one internal flash memory (or hypervisor key) that is installed in the USB connector on the drive cage.

To install the internal flash memory, complete the following steps:

1. Read the safety information that begins on page v and “Installation guidelines” on page 30.
2. Turn off the server and peripheral devices, and disconnect the power cord and all external cables.
3. Remove the cover (see “Removing the top cover” on page 39).
4. Locate the USB connector on the drive cage and insert the internal flash memory into the connector.

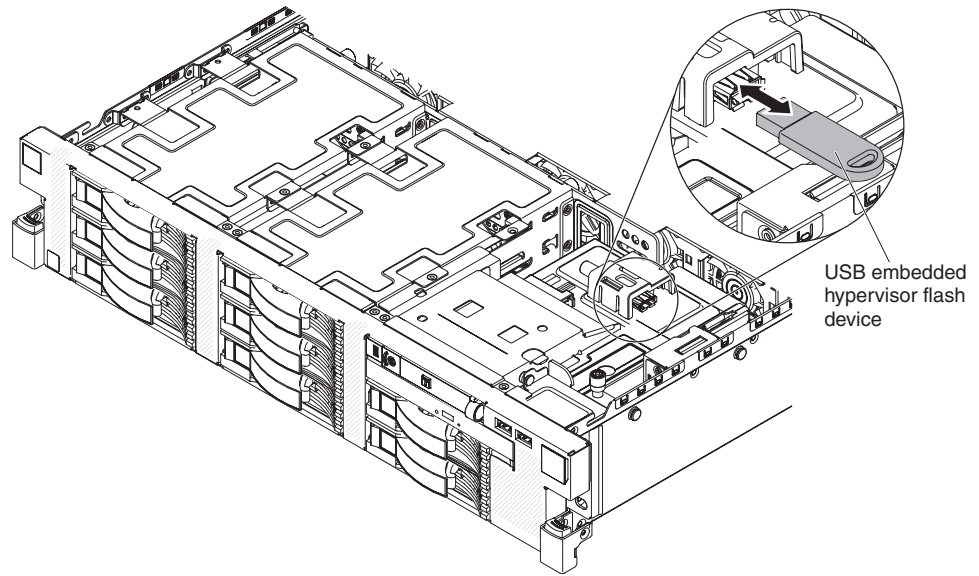

If you have other devices to install or remove, do so now. Otherwise, go to “Completing the installation” on page 70.

Memory modules (DIMMs)

The server supports up to 32 DIMMs. DIMMs in connectors 1 to 8 support microprocessor 1, DIMMs in connectors 9 to 16 support microprocessor 2, DIMMs in connectors 17 and 24 support microprocessor 3, and DIMMs in connectors 25 to 32 support microprocessor 4. The following illustration shows the DIMM connectors on the system board.

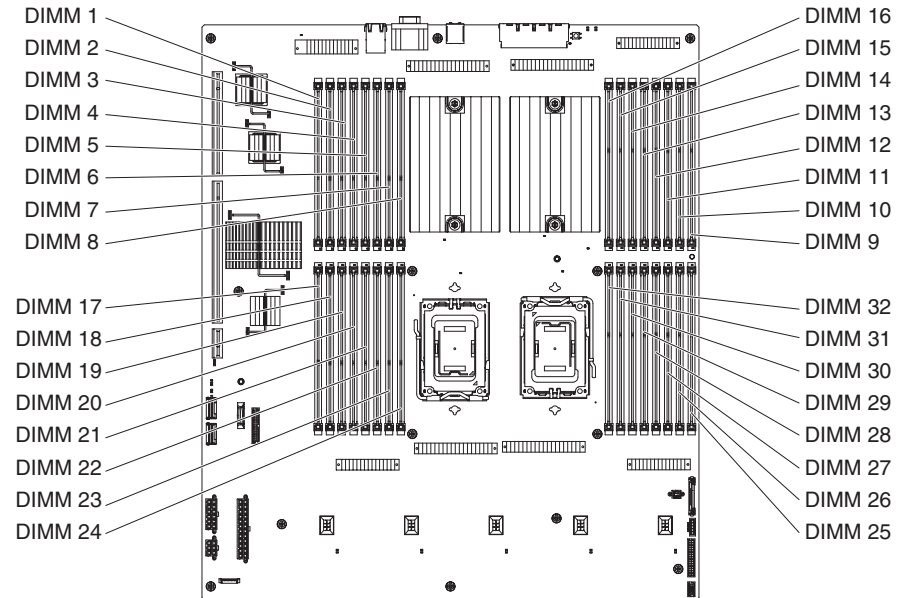

The following notes describe the types of dual inline memory modules (DIMMs) that the server supports and other information that you must consider when you install DIMMs:

- To confirm that the server supports the DIMM that you are installing, see <http://www.ibm.com/systems/info/x86servers/serverproven/compat/us/>.
- The server supports 2 GB, 4 GB, 8 GB, and 16 GB double data-rate (DDR) III, registered or unbuffered synchronous dynamic random-access memory (SDRAM) with error correcting code (ECC) DIMMs. These DIMMs must be compatible with the latest PC3-10600 or PC3-8500 SDRAM Registered DIMM specifications.

Note: The amount of usable memory is reduced depending on the system configuration. A certain amount of memory must be reserved for system resources. To view the total amount of installed memory and the amount of configured memory, run the Setup utility. For additional information, see Chapter 3, “Configuring the server,” on page 77.

- At least one pair of DIMMs must be installed for the server to operate.
- The following rules apply to ranked DDR3 DIMM speed as it relates to the number of DIMMs in a channel:

Table 3. DIMM speed

DIMMs in each channel	DIMM type	DIMM speed	
		1.5 V	1.35 V
1	Single-rank, dual-rank	1333	1333
	Quad-rank	1333	1066

Table 3. DIMM speed (continued)

DIMMs in each channel	DIMM type	DIMM speed	
		1.5 V	1.35 V
2	Single-rank, dual-rank	1333	1333
	Quad-rank, single-rank/dual-rank	1066	800
	Quad-rank	1066	800

- Do not install registered and unbuffered DIMMs in the same server.
- When you install additional DIMMs on the server, be sure to install them in pairs. The DIMMs in each pair must match each other.
- You do not have to save new configuration information to the iBMC when you install or remove DIMMs. The only exception is if you replace a DIMM that was designated as disabled in the Setup utility **Memory Settings** menu. In this case, you must re-enable the row in the Setup utility or reload the default memory settings.
- When you restart the server after you add or remove a DIMM, the server displays a message that the memory configuration has changed.
- **Non-sparing (normal) mode:** When you use the non-sparing mode, install DIMMs as indicated in the following tables.
The following table lists the DIMM installation sequence (per pair) for non-sparing mode when two or four microprocessors are installed in the server.

Table 4. Non-sparing mode memory installation sequence (in pairs)

Number of microprocessors	DIMM connectors
2	1, 9, 5, 13, 3, 7, 11, 15, 2, 6, 10, 14, 4, 8, 12, 16
4	1, 9, 17, 25, 5, 13, 21, 29, 3, 7, 11, 15, 19, 23, 27, 31, 2, 6, 10, 14, 18, 22, 26, 30, 4, 8, 12, 16, 20, 24, 28, 32

- **Online-spare mode:** The memory online-spare feature disables the failed DIMM from the system configuration and activates an online-spare DIMM to replace the failed active DIMM. You can enable online-spare memory in the Setup utility (see “Setup utility menu choices” on page 78). When you use the memory online-spare feature, consider the following information:
 - The memory online-spare feature does not support quad-rank DIMMs.
 - When you enable the memory online-spare feature, you must install a pair of DIMMs per microprocessor at a time. The DIMMs must be identical in rank and speed.
 - The maximum available memory is reduced to one-half of the installed memory when two single-rank DIMMs are used. The maximum available memory is reduced to one-third of the installed memory when one single-rank DIMM and one dual-rank DIMM are used.
 - You must install at least two DIMMs for each microprocessor in the server before you use the internal flash memory for VMware.
 - The following table lists the DIMM installation sequence for online-spare mode when two or four microprocessors are installed in the server.

Table 5. Online-spare mode memory installation sequence (in pairs)

Number of microprocessors	DIMM connectors
2	1, 2, 9, 10, 3, 4, 11, 12, 5, 6, 13, 14, 7, 8, 15, 16
4	1, 2, 9, 10, 17, 18, 25, 26, 3, 4, 11, 12, 19, 20, 27, 28, 5, 6, 13, 14, 21, 22, 29, 30, 7, 8, 15, 16, 23, 24, 31, 32

Installing a memory module

To install a DIMM, complete the following steps:

1. Read the safety information that begins on page v and “Installation guidelines” on page 30.
2. Turn off the server and peripheral devices, and disconnect the power cords and all external cables.
3. Remove the cover (see “Removing the top cover” on page 39).
4. Remove the air baffle (see “Removing the air baffle” on page 41).
5. Open the retaining clips on each end of the DIMM connector.

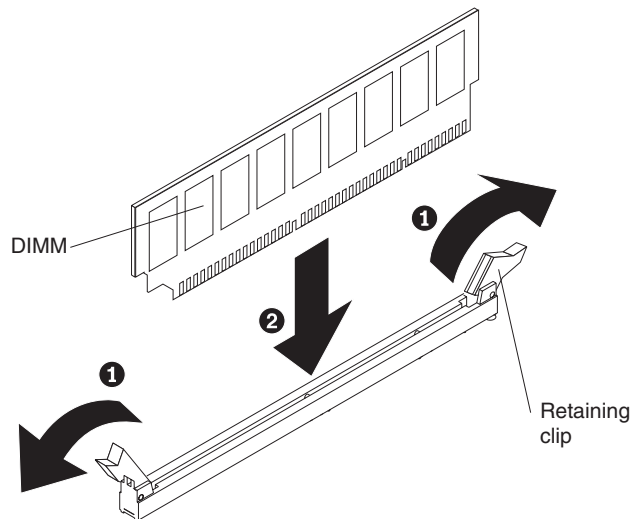

6. Touch the static-protective package that contains the DIMM to any *unpainted* metal surface on the server. Then, remove the DIMM from the package.
7. Turn the DIMM so that the DIMM keys align correctly with the slot.
8. Insert the DIMM into the connector by aligning the edges of the DIMM with the slots at the ends of the DIMM connector. Firmly press the DIMM straight down into the connector by applying pressure on both ends of the DIMM simultaneously. The retaining clips snap into the locked position when the DIMM is seated in the connector.

Note: If there is a gap between the DIMM and the retaining clips, the DIMM has not been correctly inserted; open the retaining clips, remove the DIMM, and then reinsert it.

If you have other devices to install or remove, do so now. Otherwise, go to “Completing the installation” on page 70.

Installing a microprocessor

The following notes describe the type of microprocessor that the server supports and other information that you must consider when you install a microprocessor:

- Microprocessors are to be installed only by trained service technicians.
- Always use the microprocessor installation tool to install a microprocessor. Failing to use the microprocessor installation tool may damage the microprocessor sockets on the system board. Any damage to the microprocessor sockets may require replacing the system board.
- To confirm that the server supports the microprocessor that you are installing, see <http://www.ibm.com/systems/info/x86servers/serverproven/compat/us/>.
- The server supports up to two or up to four multi-core AMD Opteron™ microprocessors. If you are installing two or more microprocessors, they must be the same cache size and type, and the same clock speed.
- The server can operate as a symmetric multiprocessing (SMP) server. With SMP, certain operating systems and application programs can distribute the processing load among the microprocessors. This enhances performance for database and point-of-sale applications, integrated manufacturing solutions, and other applications.
- Read the documentation that comes with the microprocessor to determine whether you have to update the IBM System x Server Firmware (server firmware). To download the most current level of server firmware, go to <http://www.ibm.com/systems/support/>.
- Obtain an SMP-capable operating system. For a list of supported operating systems, see <http://www.ibm.com/servers/eserver/serverproven/compat/us/>.
- As of the date of this document, SUSE Linux Enterprise Server 11 Service Pack 1 does not support XEN virtualization on a server using AMD Opteron 6200 series microprocessors.
- You can use the Setup utility to determine the specific type of microprocessor in the server.
- Each microprocessor socket must always contain either a socket dust cover or a microprocessor and heat sink.
- The pins on the sockets are fragile. Any damage to the pins might require replacing the system board.
- Populate the microprocessor sockets in the following order: 1, 2, 3, 4. The following illustration shows the locations of the microprocessor sockets on the system board.

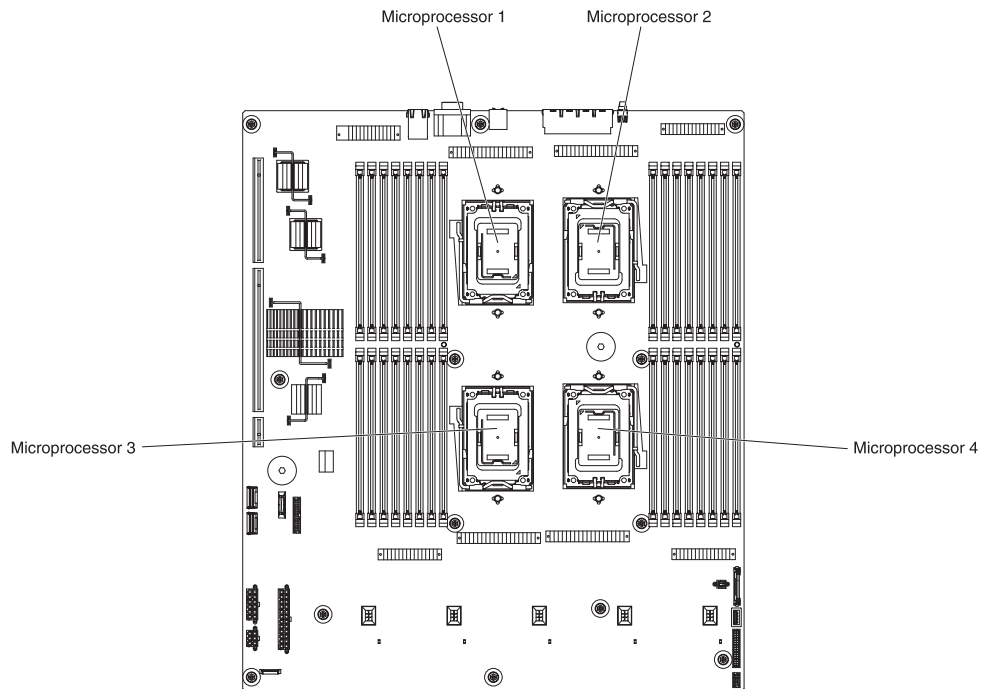

To install a microprocessor, complete the following steps:

1. Read the safety information that begins on page v and “Installation guidelines” on page 30.
2. Turn off the server and peripheral devices, and disconnect the power cords and all external cables.
3. Remove the cover (see “Removing the top cover” on page 39).
4. Remove the PCI riser-card assembly (see “Removing the PCI riser-card assembly” on page 40).
5. Remove the air baffle (see “Removing the air baffle” on page 41).

Attention: When you handle static-sensitive devices, take precautions to avoid damage from static electricity. For details about handling these devices, see “Handling static-sensitive devices” on page 32.

6. Install the microprocessor:
 - a. Rotate the microprocessor release lever on the socket from its closed and locked position until it stops in the fully open position.

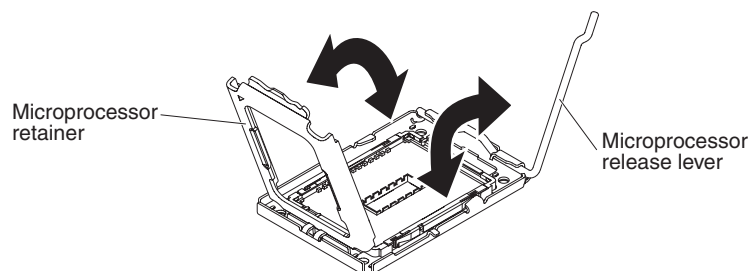

- b. Rotate the hinged microprocessor bracket frame into the open position.
 - c. Remove the microprocessor socket dust cover from the surface of the microprocessor socket, if one is present. Store the dust cover in a safe place.

- d. Touch the static-protective package that contains the microprocessor to any *unpainted* metal surface on the server. Then, remove the microprocessor from the package.

Attention:

- Handle the microprocessor carefully. Dropping the microprocessor during installation or removal can damage the contacts.
- Do not touch the microprocessor contacts; handle the microprocessor by the edges only. Contaminants on the microprocessor contacts, such as oil from your skin, can cause connection failures between the contacts and the socket.
- Do not use excessive force when you press the microprocessor into the socket.
- Make sure that the microprocessor is oriented and aligned and positioned in the socket before you try to close the lever.

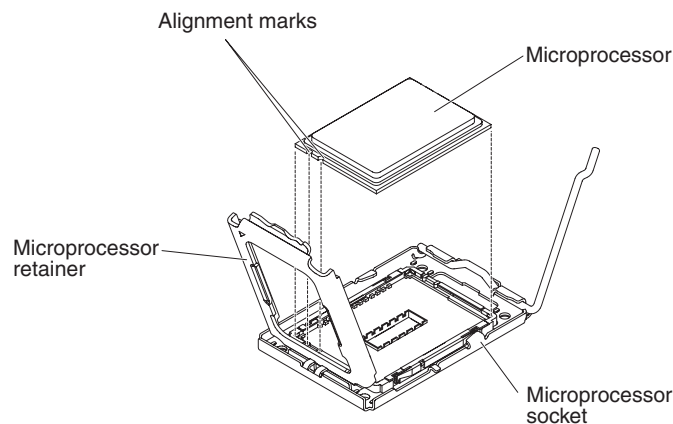

- e. Align the microprocessor with the socket (note the alignment mark and the position of the notches); then, carefully place the microprocessor straight down on the socket. Close the microprocessor bracket frame.

Attention: The microprocessor fits only one way on the socket. You must place a microprocessor straight down on the socket to avoid damaging the pins on the socket. The pins on the socket are fragile. Any damage to the pins might require replacing the system board.

- f. Carefully close the microprocessor release lever to secure the microprocessor in the socket.

7. Install a heat sink on the microprocessor.

Attention: Do not touch the thermal grease on the bottom of the heat sink or set down the heat sink after you remove the plastic cover. Touching the thermal grease will contaminate it.

- a. Remove the screws (if installed) from the heat sink screw holes on the system board.
- b. Remove the plastic protective cover from the bottom of the heat sink.
- c. If the new heat sink did not come with thermal grease, apply thermal grease on the microprocessor before you install the heat sink (see “Thermal grease” on page 69).
- d. Orient the heat sink so that the side with the number **1** on the label faces the front of the server.
- e. Align the screws on the heat sink with the screw holes on the system board; then, place the heat sink on the microprocessor with the thermal-grease side down.

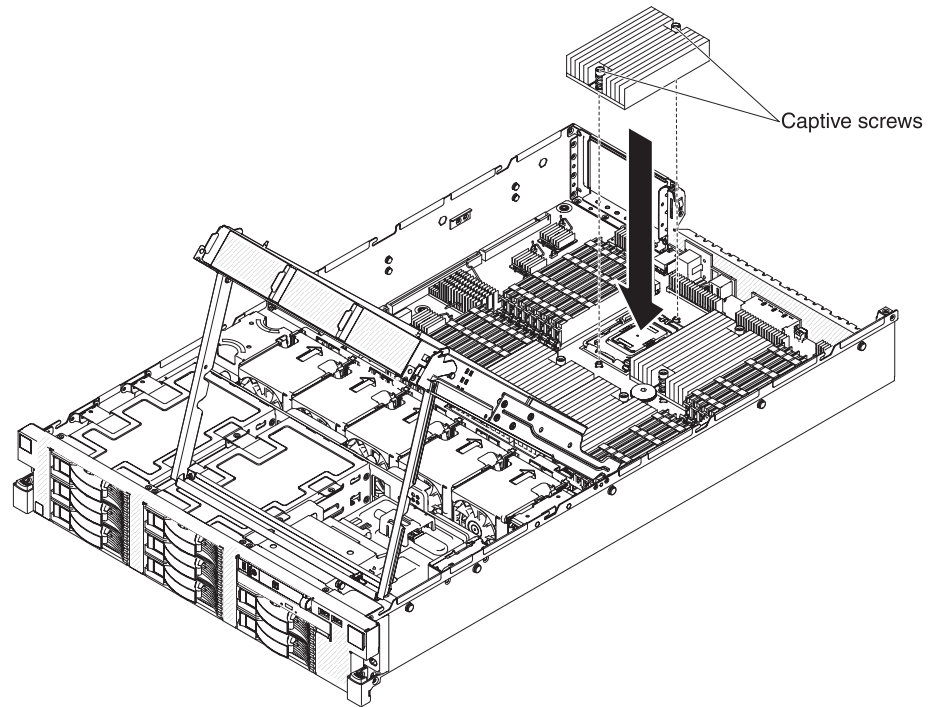

- f. Tighten the screws with a screwdriver, alternating among the screws until they are tight. If possible, each screw should be rotated two full rotations at a time. Repeat until the screws are tight. Do not overtighten the screws by using excessive force.

If you have other devices to install or remove, do so now. Otherwise, go to “Completing the installation” on page 70.

Thermal grease

The thermal grease must be replaced whenever the heat sink has been removed from the top of the microprocessor and is going to be reused or when debris is found in the grease.

When you are installing the heat sink on the same microprocessor that is was removed from, make sure that the following requirements are met:

- The thermal grease on the heat sink and microprocessor is not contaminated.
- Additional thermal grease is not added to the existing thermal grease on the heat sink and microprocessor.

To replace damaged or contaminated thermal grease on the microprocessor and heat sink, complete the following steps:

1. Place the heat sink on a clean work surface.
2. Remove the alcohol wipe from its package and unfold it completely.
3. Use the alcohol wipe to clean the thermal grease from the bottom of the heat sink.

Note: Make sure that all of the thermal grease is removed.

4. Use a clean area of the alcohol wipe to clean the thermal grease from the microprocessor; then, dispose of the alcohol wipe after all of the thermal grease is removed.

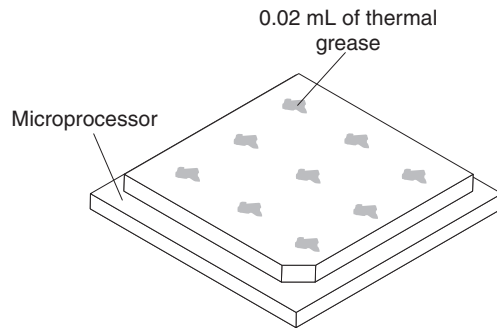

5. Use the thermal-grease syringe to place 9 uniformly spaced dots of 0.02 mL each on the top of the microprocessor. The outermost dots must be within 5 mm of the edge.

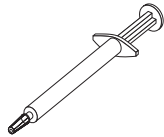

Note: 0.01mL is one tick mark on the syringe. If the grease is properly applied, approximately half of the grease will remain in the syringe.

6. Install the heat sink onto the microprocessor as described in “Installing a microprocessor” on page 66.

Completing the installation

To complete the installation, complete the following steps:

1. If you removed the PCI riser-card assembly, replace it (see “Installing the PCI riser-card assembly”).
2. If you removed the air baffle, replace it (see “Installing the air baffle” on page 71).
3. If you removed the top cover, replace it(see “Installing the top cover” on page 73).
4. If you removed the top-cover fan door, replace it (see “Installing the top-cover fan door” on page 73).
5. Install the server in a rack. See the *Rack Installation Instructions* that come with the server for complete rack installation and removal instructions.
6. Connect the cables and power cords to the rear of the server. For more information, see “Connecting the cables” on page 74.
7. (IBM Business Partners only) Complete the additional steps in “Instructions for IBM Business Partners” on page 21.

Installing the PCI riser-card assembly

To install the PCI riser-card assembly, complete the following steps:

1. Make sure that all internal cables are correctly routed and that no cables are pinched.
2. Align the PCI riser-card assembly with the PCI connectors on the system board and align the nailheads with the slots on the chassis; then, lower the PCI riser-card assembly into the server.

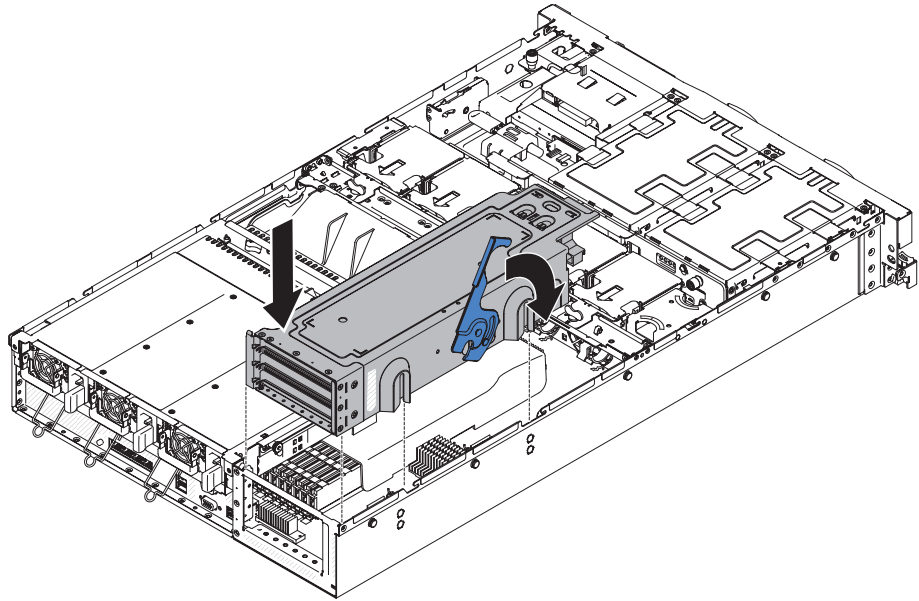

3. Press the handle down to securely latch the PCI riser-card assembly into place.

Installing the air baffle

To install the air baffle, complete the following steps:

1. Make sure that all internal cables are correctly routed and that no cables are pinched.
2. Align the air baffle with the slots on the chassis; then, insert the tabs into the slots and lower the air baffle into the server.

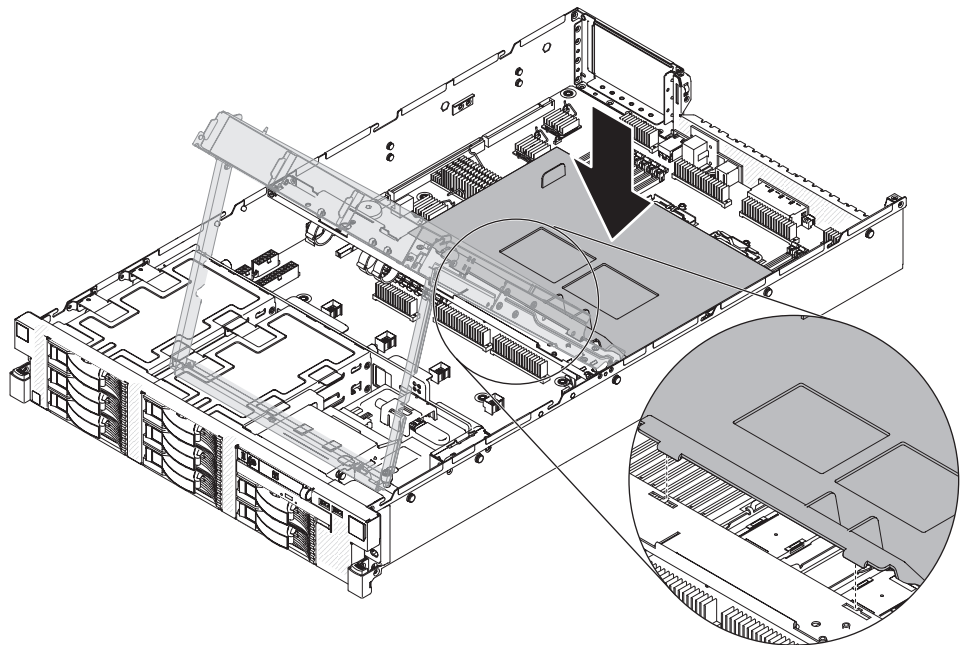

3. Press the release latch on the handle to disengage the handle from the chassis; then, carefully rotate the power-supply cage toward the rear of the server and lower the power-supply cage into place.

Note: The power-supply cage might be heavy, depending on the number of power supplies that are installed. Support the power-supply cage with both hands while you rotate it into position.

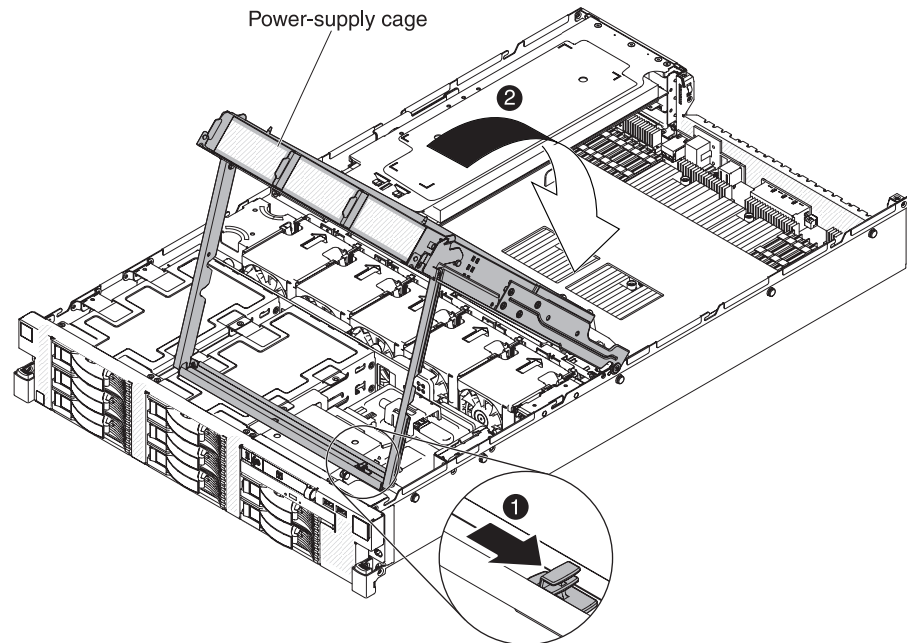

4. While you hold the handle, pull the release pin on the side of the handle and lower the handle into the closed position.

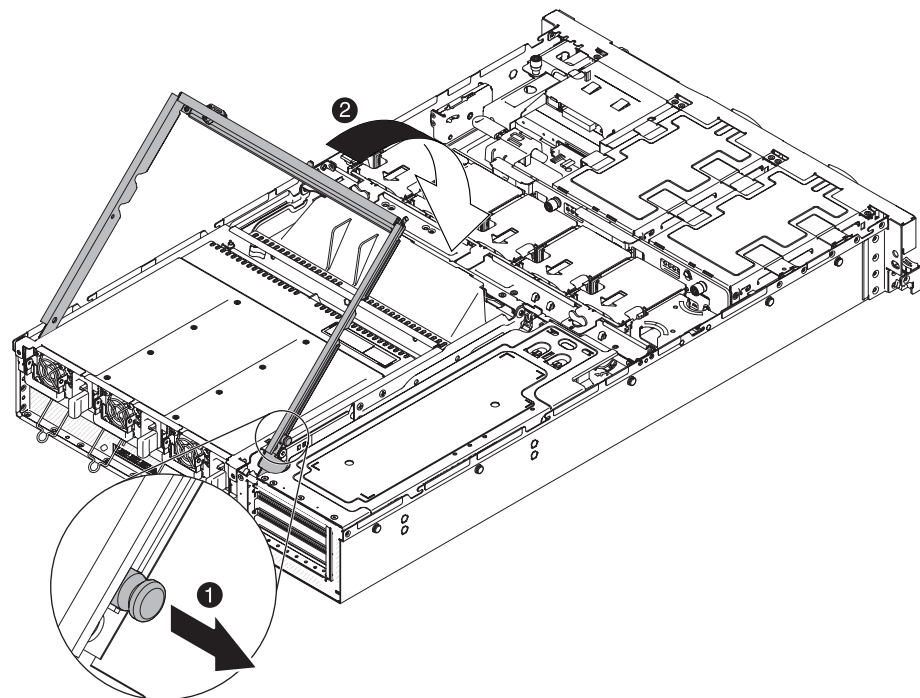

Installing the top cover

To install the top cover, complete the following steps:

1. Make sure that all internal cables are correctly routed.
2. Set the cover on top of the server so that approximately 13 mm (0.5 inch) extends from the rear.
3. Align the cover over the server (toward the rear of the server) until the cover edges slip into position over the chassis.

Attention: Before you slide the cover forward, make sure that all the tabs on both the front and side of the cover engage the chassis correctly. If all the tabs do not engage the chassis correctly, it will be hard to remove the cover later.

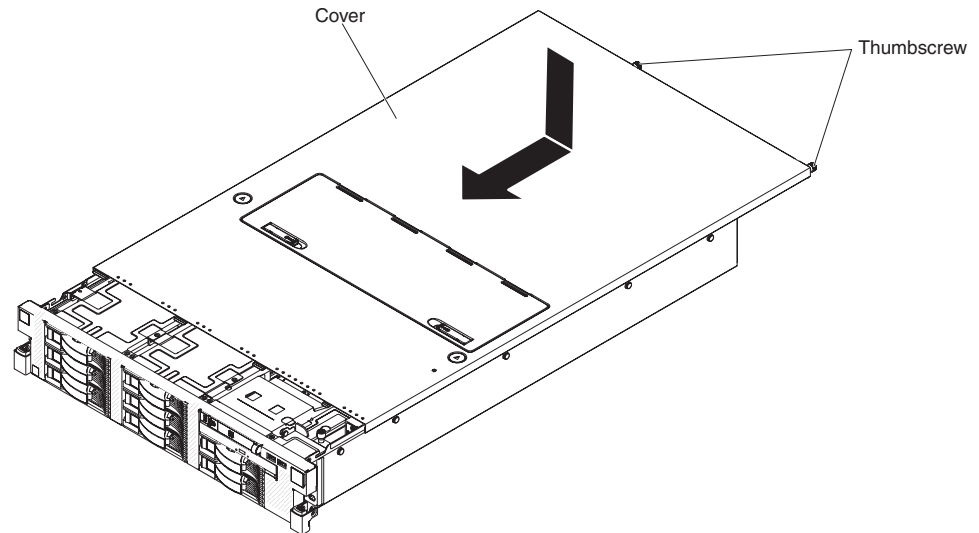

4. Slide the top cover forward and into position; then, tighten the thumbscrews to secure the cover to the chassis.
5. If necessary, reconnect the power cords and all external cables, and then turn on the server.
6. Slide the server into the rack.

Installing the top-cover fan door

To install the top-cover fan door, complete the following steps:

1. Align the top-cover fan door so that the metal tabs line up correctly on the top cover, and then rotate it into place.

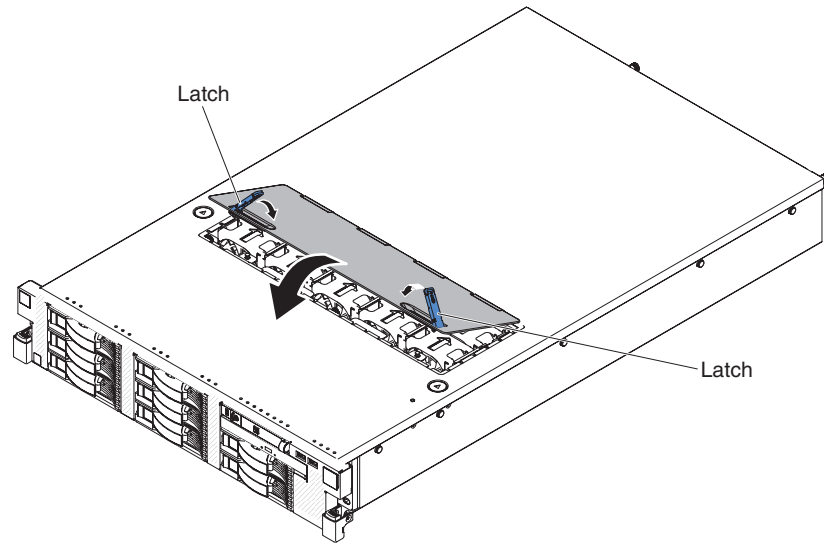

2. Press the release latches on the top-cover fan door to lock it in place.
3. If necessary, reconnect the power cords and all external cables, and then turn on the server.
4. Slide the server into the rack.

Connecting the cables

Notes:

1. Be sure to turn off the server before you connect any cables to or disconnect any cables from the server.
2. For additional cabling instructions, see the documentation that comes with the optional devices. It might be easier for you to route any cables before you install certain optional devices.

The following illustration shows the locations of the input and output connectors on the rear of the server.

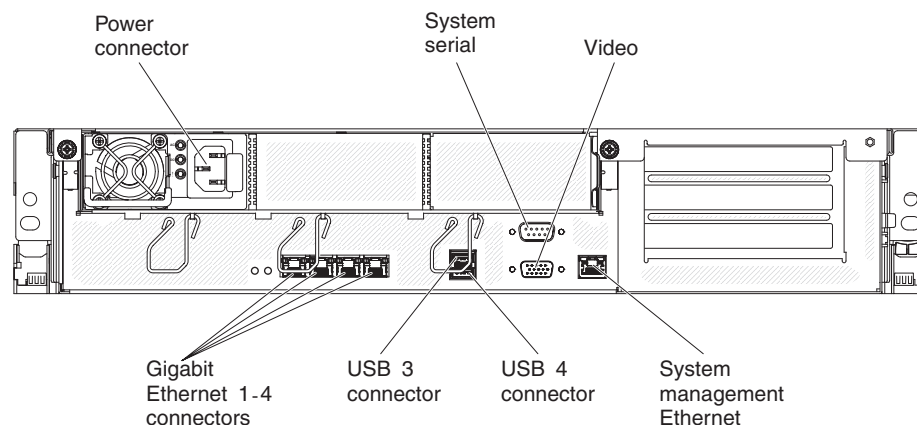

Updating the server configuration

When you start the server for the first time after you add or remove a device, you might receive a message that the configuration has changed. The Setup utility starts automatically so that you can save the new configuration settings. For more information, see Chapter 3, “Configuring the server,” on page 77.

Some optional devices have device drivers that you must install. For information about installing device drivers, see the documentation that comes with each device.

The server comes with at least two microprocessors and can operate as a symmetric multiprocessing (SMP) server. You might have to upgrade the operating system to support SMP. For more information, see “Typical operating-system installation” on page 84 and the operating-system documentation.

If the server has an optional RAID adapter and you have installed or removed a hard disk drive, see the documentation that comes with the RAID adapter for information about reconfiguring the disk arrays.

For information about configuring the integrated Gigabit Ethernet controller, see “Configuring the Broadcom Gigabit Ethernet controller” on page 87.

Chapter 3. Configuring the server

The following configuration programs come with the server:

- **Setup utility**

The Setup utility (formerly called the Configuration/Setup Utility program) is part of the IBM System x Server Firmware (server firmware). Use it to perform configuration tasks such as changing the startup-device sequence, setting the date and time, and setting passwords. For information about using this program, see “Using the Setup utility” on page 78.

- **Boot Selection Menu program**

The Boot Selection Menu program is part of the server firmware. Use it to override the startup sequence that is set in the Setup utility and temporarily assign a device to be first in the startup sequence. For more information about using this program, see “Using the Boot Selection Menu program” on page 82.

- **IBM ServerGuide Setup and Installation CD**

The ServerGuide program provides software-setup tools and installation tools that are designed for the server. Use this CD during the installation of the server to configure basic hardware features, such as an integrated SAS controller with RAID capabilities, and to simplify the installation of your operating system. For information about obtaining and using this CD, see “Using the ServerGuide Setup and Installation CD” on page 83.

- **Integrated baseboard management controller**

Use the integrated baseboard management controller (iBMC) for configuration, to update the firmware and sensor data record/field replaceable unit (SDR/FRU) data, and to remotely manage a network. For information about using the iBMC, see “Using the integrated baseboard management controller” on page 85 or the *Problem Determination and Service Guide* on the IBM Documentation CD.

- **VMware embedded USB hypervisor**

The VMware embedded USB hypervisor is available on the server models that come with an installed USB Memory Key for VMware hypervisor. The USB memory key is installed in the USB connector in the server. Hypervisor is virtualization software that enables multiple operating systems to run on a host computer at the same time.

- **Remote presence and blue-screen capture features**

The remote presence feature provides the following functions:

- Remotely viewing video with graphics resolutions up to 1280 x 1024 at 75 Hz, regardless of the system state
- Remotely accessing the server, using the keyboard and mouse from a remote client
- Mapping the CD or DVD drive, diskette drive, and USB flash drive on a remote client, and mapping ISO and diskette image files as virtual drives that are available for use by the server
- Uploading a diskette image to the iBMC memory and mapping it to the server as a virtual drive

The blue-screen capture feature captures the video display contents before the iBMC restarts the server when the iBMC detects an operating-system hang condition. A system administrator can use the blue-screen capture feature to assist in determining the cause of the hang condition.

For more information, see “Using the remote presence and blue-screen capture features” on page 87.

- **Ethernet controller configuration**

For information about configuring the Ethernet controller, see “Configuring the Broadcom Gigabit Ethernet controller” on page 87.

- **IBM Advanced Settings Utility (ASU) program**

Use this program as an alternative to the Setup utility for modifying UEFI settings. Use the ASU program inband or out of band to modify UEFI settings from the command line without the need to restart the server to run the Setup utility. For information about using this program, see “Using the IBM Advanced Settings Utility program” on page 88.

Using the Setup utility

Use the Setup utility, to perform the following tasks:

- View configuration information
- View and change assignments for devices and I/O ports
- Set the date and time
- Set and change passwords
- Set the startup characteristics of the server and the order of startup devices
- Set and change settings for advanced hardware features
- View, set, and change settings for power-management features
- View and clear error logs
- Resolve configuration conflicts

Starting the Setup utility

To start the Setup utility, complete the following steps:

1. Turn on the server.

Note: Approximately 1 minute after the server is turned on, the screen displays the boot process status.

2. When the prompt <F1> Setup is displayed, press F1. If you have set an administrator password, you must type the administrator password to access the full Setup utility menu. If you do not type the administrator password, a limited Setup utility menu is available.
3. Select the settings to view or change.

Setup utility menu choices

The following choices are on the Setup utility main menu. Depending on the version of the UEFI firmware, some menu choices might differ slightly from these descriptions.

- **System Information**

Select this choice to view information about the server. When you make changes through other choices in the Setup utility, some of those changes are reflected in the system information; you cannot change settings directly in the system information. This choice is on the full Setup utility menu only.

- **System Summary**

Select this choice to view configuration information, including the ID, speed, and cache size of the microprocessors; machine type and model of the server; the serial number; the system UUID; and the amount of installed memory. When you make configuration changes through other choices in the

Setup utility, the changes are reflected in the system summary; you cannot change settings directly in the system summary.

- **Product Data**

Select this choice to view the revision level or issue date of the firmware, integrated management module II and diagnostics code, and the version and date.

- **System Settings**

Select this choice to view or change the server component settings. This choice is on the full Setup utility menu only.

- **Processors**

Select this choice to view or change the processor settings.

- **Memory**

Select this choice to view or change the memory settings. To configure memory mirroring, select **System Settings** → **Memory**, and then select **Memory Mode** → **Mirroring**.

- **Devices and I/O Ports**

Select this choice to view or change assignments for devices and input/output (I/O) ports. You can configure the serial ports, configure remote console redirection, and enable or disable integrated Ethernet controllers and PCI slots. If you disable a device, it cannot be configured, and the operating system will not be able to detect it (this is equivalent to disconnecting the device).

- **Power**

Select this choice to view or change power capping to control consumption, processors, and performance states.

- **Legacy Support**

Select this choice to view or set legacy support.

- **Force Legacy Video on Boot**

Select this choice to force INT video support, if the operating system does not support UEFI video output standards.

- **Rehook INT**

Select this choice to enable or disable devices from taking control of the boot process. The default is **Disable**.

- **Integrated Management Module II (IMM2)**

Select this choice to view or change the settings for the integrated management module II (IMM2).

- **Commands on USB Interface Preference**

Select this choice to enable or disable the Ethernet over USB interface on the IMM2.

- **Network Configuration**

Select this choice to view the system management network interface port, the IMM2 MAC address, the current IMM2 IP address, and the host name; define the static IMM2 IP address, subnet mask, and gateway address; specify whether to use the static IP address or have DHCP assign the IMM2 IP address; and save the network changes.

- **Reset IMM to Defaults**

Select this choice to view or reset the IMM2 to the default settings.

- **Reset IMM**

Select this choice to reset the IMM.

- **Date and Time**
Select this choice to set the date and time in the server, in 24-hour format (*hour.minute:second*).
This choice is on the full Setup utility menu only.
- **Start Options**
Select this choice to view the startup sequence or boot to devices. The servers starts from the first boot record that it finds.
This choice is on the full Setup utility menu only.
- **Boot Manager**
Select this choice to view, add, or change the device boot priority, boot from a file, select a one-time boot, or reset the boot order to the default setting.
- **System Event Logs**
Select this choice to view the system-event log and the POST event log.

Important:: If the system-error LED on the front of the server is lit but there are no other error indications, clear the system-event log. Also, after you complete a repair or correct an error, clear the system-event log to turn off the system-error LED on the front of the server.

- **POST Event Viewer**

Select this choice to enter the POST event viewer to view the error messages in the POST event log.

- **System Event Log**

Select this choice to view the error messages in the system-event log.

- **Clear System Event Log**

Select this choice to clear the system-event log.

- **User Security**

Select this choice to set, change, or clear passwords. For information about passwords, see “Passwords” on page 81.

This choice is on the full and limited Setup utility menu.

- **Set Power-on Password**

Select this choice to set or change a power-on password. For more information, see “Power-on password” on page 81.

- **Clear Power-on Password**

Select this choice to clear a power-on password.

- **Set Admin Password**

Select this choice to set or change an administrator password. An administrator password is intended to be used by a system administrator; it limits access to the full Setup utility menu. If an administrator password is set, the full Setup utility menu is available only if you type the administrator password at the password prompt. For more information, see “Administrator password” on page 82.

Attention: If you set an administrator password and then forget it, there is no way to change, override, or remove it. You must replace the system board.

- **Clear Admin Password**

Select this choice to clear an administrator password. For more information, see “Administrator password” on page 82.

- **Save Settings**

Select this choice to save the changes that you have made in the settings.

- **Restore Settings**

Select this choice to cancel the changes that you have made in the settings and restore the previous settings.

- **Load Default Settings**

Select this choice to cancel the changes that you have made in the settings and restore the factory settings.

- **Exit Setup**

Select this choice to exit from the Setup utility. If you have not saved the changes that you have made in the settings, you are asked whether you want to save the changes or exit without saving them.

Passwords

From the **User Security** menu choice, you can set, change, and delete a power-on password and an administrator password. The **User Security** choice is on the full Setup utility menu only.

If you set only a power-on password, you must type the power-on password to complete the system startup and to have access to the Setup utility menu.

An administrator password is intended to be used by a system administrator; it limits access to the full Setup utility menu. If you set only an administrator password, you do not have to type a password to complete the system startup, but you must type the administrator password to access the Setup utility menu.

If you set a power-on password for a user and an administrator password for a system administrator, you can type either password to complete the system startup. A system administrator who types the administrator password has access to the full Setup utility menu; the system administrator can give the user authority to set, change, and delete the power-on password. A user who types the power-on password has access to only the limited Setup utility menu; the user can set, change, and delete the power-on password, if the system administrator has given the user that authority.

Power-on password

If a power-on password is set, when you turn on the server, the system startup will not be completed until you type the power-on password. You can use any combination of 6 - 20 printable ASCII characters for the password.

When a power-on password is set, you can enable the Unattended Start mode, in which the keyboard and mouse remain locked but the operating system can start. You can unlock the keyboard and mouse by typing the power-on password.

If you forget the power-on password, you can regain access to the server in any of the following ways:

- If an administrator password is set, type the administrator password at the password prompt. Start the Setup utility and reset the power-on password.
- Clear the password by clearing CMOS memory (see “System-board jumpers” on page 27).
- Remove the battery from the server and then reinstall it. For instructions for removing the battery, see the *Problem Determination and Service Guide* on the IBM Documentation CD.

Attention: Before you change any switch settings or move any jumpers, turn off the server; then, disconnect all power cords and external cables. See the safety information that begins on page v. Do not change settings or move jumpers on any system-board switch or jumper blocks that are not shown in this document.

Administrator password

An administrator password is intended to be used by a system administrator; it limits access to the full Setup utility menu.

If an administrator password is set, you must type the administrator password for access to the full Setup utility menu. You can use any combination of 6 - 20 printable ASCII characters for the password.

If you forget the administrator password, you can clear the password by clearing CMOS memory (see “System-board jumpers” on page 27).

Using the Boot Selection Menu program

The Boot Selection Menu is used to temporarily redefine the first startup device without changing boot options or settings in the Setup utility.

To use the Boot Selection Menu program, complete the following steps:

1. Turn off the server.
2. Restart the server.
3. When the prompt <F12> Select Boot Device is displayed, press F12. If a bootable USB mass storage device is installed, a submenu item (**USB Key/Disk**) is displayed.
4. Use the Up Arrow and Down Arrow keys to select an item from the menu and press Enter.

The next time the server starts, it returns to the startup sequence that is set in the Setup utility.

Attention: If you install more than one bootable hard disk drive in the server, you must use the LSI Configuration Utility program to select the hard disk drive to boot from. For information on LSI Configuration Utility program, see the documentation that comes with your ServeRAID controller.

Starting the backup server firmware

The system board contains a backup copy area for the IBM System x Server Firmware (server firmware). This is a secondary copy of the server firmware that you update only during the process of updating the server firmware. If the primary copy of the server firmware becomes damaged, use this backup copy.

To force the server to start from the backup copy of the server firmware, turn off the server; then, move the UEFI boot recovery J117 jumper to the backup position (pins 2 and 3). See “System-board jumpers” on page 27 for more information.

Use the backup copy of the server firmware until the primary copy is restored. After the primary copy is restored, turn off the server; then, move the UEFI boot recovery J117 jumper back to the primary position (pins 1 and 2).

Using the ServerGuide Setup and Installation CD

The *ServerGuide Setup and Installation CD* provides software setup tools and installation tools that are designed for your server. The ServerGuide program detects the server model and optional hardware devices that are installed and uses that information during setup to configure the hardware. The ServerGuide program simplifies operating-system installations by providing updated device drivers and, in some cases, installing them automatically.

You can download a free image of the *ServerGuide Setup and Installation CD* or purchase the CD from the ServerGuide fulfillment website at <http://www.ibm.com/systems/management/serverguide/sub.html>. To download the free image, click **IBM Service and Support Site**.

Note: Changes are made periodically to the IBM website. The actual procedure might vary slightly from what is described in this document.

The ServerGuide program requires a supported IBM server with an enabled startable (bootable) CD drive. In addition to the *ServerGuide Setup and Installation CD*, you must have your operating-system CD to install the operating system.

To start the *ServerGuide Setup and Installation CD*, complete the following steps:

1. Insert the CD, and restart the server. If the CD does not start, see "ServerGuide problems" in the *Problem Determination and Service Guide* on the IBM *Documentation CD*.
2. Follow the instructions on the screen to complete the following tasks:
 - a. Select your language.
 - b. Select your keyboard layout and country.
 - c. View the overview to learn about ServerGuide features.
 - d. View the readme file to review installation tips for your operating system and adapter.
 - e. Start the operating-system installation. you will need your operating-system CD.

ServerGuide features

Features and functions can vary slightly with different versions of the ServerGuide program. To learn more about the version that you have, start the *ServerGuide Setup and Installation CD* and view the online overview. Not all features are supported on all server models.

The ServerGuide program has the following features:

- An easy-to-use interface
- Diskette-free setup, and configuration programs that are based on detected hardware
- Device drivers that are provided for the server model and detected hardware
- Operating-system partition size and file-system type that are selectable during setup

The ServerGuide program performs the following tasks:

- Sets system date and time
- Detects the RAID adapter or controller and runs the SAS RAID configuration program (with LSI chip sets for ServerRAID adapters only)

- Checks the microcode (firmware) levels of a ServeRAID adapter and determines whether a later level is available from the CD
- Detects installed optional hardware devices and provides updated device drivers for most adapters and devices
- Provides diskette-free installation for supported Windows operating systems
- Includes an online readme file with links to tips for hardware and operating-system installation

Setup and configuration overview

When you use the *ServerGuide Setup and Installation* CD, you do not need setup diskettes. You can use the CD to configure any supported IBM server model. The setup program provides a list of tasks that are required to set up your server model. On a server with a ServeRAID adapter or integrated SCSI controller with RAID capabilities, you can run the SCSI RAID configuration program to create logical drives.

Note: Features and functions can vary slightly with different versions of the ServerGuide program.

Typical operating-system installation

The ServerGuide program can reduce the time it takes to install an operating system. It provides the device drivers that are required for your hardware and for the operating system that you are installing. This section describes a typical ServerGuide operating-system installation.

Note: Features and functions can vary slightly with different versions of the ServerGuide program.

1. After you have completed the setup process, the operating-system installation program starts. (You will need your operating-system CD to complete the installation.)
2. The ServerGuide program stores information about the server model, service processor, hard disk drive controllers, and network adapters. Then, the program checks the CD for newer device drivers. This information is stored and then passed to the operating-system installation program.
3. The ServerGuide program presents operating-system partition options that are based on your operating-system selection and the installed hard disk drives.
4. The ServerGuide program prompts you to insert your operating-system CD and restart the server. At this point, the installation program for the operating system takes control to complete the installation.

Important: Before you install a UEFI operating system on a server with a ServeRAID controller, you must first complete the following steps:

1. Update the device driver for the SAS controller to the latest level.
2. In the Setup utility, select **System Settings & rarr; Device and I/O ports**.
3. Select **Launch storage OpROM**; then, select **UEFI driver**.
4. Save the settings and exit from the Setup utility.

Important: To enable the server to boot from a legacy operating-system CD, complete the following steps:

1. In the Setup utility, select **Boot Manager**.
2. Select **CD/DVD Drive BBS Priorities**; then, select the optical device name without the "UEFI" prefix.

3. Save the settings and exit from the Setup utility.

Installing your operating system without using ServerGuide

If you have already configured the server hardware and you are not using the ServerGuide program to install your operating system, complete the following steps to download the latest operating-system installation instructions from the IBM website.

Note: Changes are made periodically to the IBM website. The actual procedure might vary slightly from what is described in this document.

1. Go to <http://www.ibm.com/systems/support/>.
2. Under **Product support**, click **System x**.
3. From the menu on the left side of the page, click **System x support search**.
4. From the **Task** menu, select **Install**.
5. From the **Product family** menu, select **System x3755 M3**.
6. From the **Operating system** menu, select your operating system, and then click **Search** to display the available installation documents.

Using the integrated baseboard management controller

The integrated baseboard management controller (iBMC) is a second generation of the functions that were formerly provided by the baseboard management controller hardware. It combines service processor functions, video controller, and remote presence function in a single chip.

The iBMC supports the following basic systems-management features:

- Alerts (in-band and out-of-band alerting, PET traps - IPMI style, SNMP, email).
- Auto Boot Failure Recovery.
- Automatic Server Restart (ASR) when POST is not complete or the operating system hangs and the operating-system watchdog timer times out. The iBMC might be configured to watch for the operating-system watchdog timer and restart the server after a timeout, if the ASR feature is enabled. Otherwise, the iBMC allows the administrator to generate an NMI by pressing a nonmaskable interrupt button on the information panel for an operating-system memory dump. ASR is supported by the Intelligent Platform Management Interface (IPMI).
- Boot sequence manipulation.
- Command-line interface.
- Configuration save and restore.
- DIMM error assistance. The Unified Extensible Firmware Interface (UEFI) disables a failing DIMM that is detected during POST, and the iBMC lights the associated system-error LED and the failing DIMM error LED.
- Environmental monitor with fan speed control for temperature, voltages, fan failure, and power supply failure.
- Intelligent Platform Management Interface (IPMI) Specification V2.0 support.
- Invalid system configuration (CNFG) LED support.
- Light path diagnostics LEDs to report errors that occur with fans, power supplies, microprocessor, hard disk drives, and system errors.
- Nonmaskable interrupt (NMI) detection and reporting.
- Operating-system failure blue screen capture.

- Power/reset control (power-on, hard and soft shutdown, hard and soft reset, schedule power control).
- Query power-supply input power.
- ROM-based iBMC firmware flash updates.
- Serial over LAN (SOL).
- System-event log.

The iBMC also provides the following remote server management capabilities through the OSA SMBridge management utility program:

- **Command-line interface (IPMI Shell)**

The command-line interface provides direct access to server management functions through the IPMI 2.0 protocol. Use the command-line interface to issue commands to control the server power, view system information, and identify the server. You can also save one or more commands as a text file and run the file as a script.

- **Serial over LAN**

Establish a Serial over LAN (SOL) connection to manage servers from a remote location. You can remotely view and change the UEFI settings, restart the server, identify the server, and perform other management functions. Any standard Telnet client application can access the SOL connection.

Obtaining the IP address for web interface access

To access the web interface, you need the IP address of the iBMC which you can obtain through the Setup utility. To obtain the IP address, complete the following steps:

1. Turn on the server.
2. When the prompt <F1> Setup is displayed, press F1. If you have set both a power-on password and an administrator password, you must type the administrator password to access the full Setup utility menu.
3. Select **System Settings** → **Integrated Baseboard Management Controller** → **Network Configuration**.
4. Locate the IP address.
5. Exit from the Setup utility.

Logging on to the web interface

To log on to the iBMC web interface, complete the following steps:

1. Open a web browser on a computer that connects to the server and in the **Address** or **URL** field, type the IP address or host name of the iBMC to which you want to connect.

Note: If you are logging on to the iBMC for the first time after installation, the iBMC defaults to DHCP. If a DHCP host is not available, the iBMC assigns a static IP address of 192.168.70.125. The MAC address tag provides the default hostname of the iBMC and does not require you to start the server.

2. On the Login page, type the user name and password. If you are using the iBMC for the first time, you can obtain the user name and password from your system administrator. All login attempts are documented in the event log.

Notes:

- a. The iBMC is set initially with a user name of USERID and password of PASSWORD (with a zero, not the letter O). You have read/write access. You must change this default password the first time you log on.
 - b. The default timeout value is 10 minutes. The iBMC will log you off the web interface if your browser is inactive for 10 minutes.
3. Click **Login** to start the session. The System Status page, provides a quick view of the server status.

Using the remote presence and blue-screen capture features

The remote presence and blue-screen capture features are integrated functions of the integrated baseboard management controller (iBMC).

The remote presence feature provides the following functions:

- Remotely viewing video with graphics resolutions up to 1600 x 1200 at 75 Hz, regardless of the system state
- Remotely accessing the server, using the keyboard and mouse from a remote client
- Mapping the CD or DVD drive, diskette drive, and USB flash drive on a remote client, and mapping ISO and diskette image files as virtual drives that are available for use by the server
- Uploading a diskette image to the iBMC memory and mapping it to the server as a virtual drive

The blue-screen capture feature captures the video display contents before the iBMC restarts the server when the iBMC detects an operating-system hang condition. A system administrator can use the blue-screen capture feature to assist in determining the cause of the hang condition.

Enabling the Broadcom Gigabit Ethernet Utility program

The Broadcom Gigabit Ethernet Utility program is part of the server firmware. You can use it to configure the network as a startable device, and you can customize where the network startup option appears in the startup sequence. Enable and disable the Broadcom Gigabit Ethernet Utility program from the Setup utility.

Configuring the Broadcom Gigabit Ethernet controller

The Ethernet controllers are integrated on the system board. They provide an interface for connecting to a 10 Mbps, 100 Mbps, or 1 Gbps network and provide full-duplex (FDX) capability, which enables simultaneous transmission and reception of data on the network. If the Ethernet ports in the server support auto-negotiation, the controllers detect the data-transfer rate (10BASE-T, 100BASE-TX, or 1000BASE-T) and duplex mode (full-duplex or half-duplex) of the network and automatically operate at that rate and mode.

You do not have to set any jumpers or configure the controllers. However, you must install a device driver to enable the operating system to address the controllers. For device drivers and information about configuring the Ethernet controllers, complete the following steps:

1. Go to <http://www.ibm.com/systems/support/>.
2. Under **Product support**, click **System x**.

3. Under **Popular links**, click **Software and device drivers**.
4. From the **Product family** menu, select **System x3755 M3** and click **Go**.

Note: Changes are made periodically to the IBM website. The actual procedure might vary slightly from what is described in this document.

Configuring RAID arrays

Through the Setup utility, you can access utilities to configure RAID arrays. The specific procedure for configuring arrays depends on the RAID controller that you are using. For details, see the documentation for your RAID controller. To access the utility for your RAID controller, complete the following steps:

1. Turn on the server.

Note: Approximately 1 minute after the server is turned on, the screen displays the boot process status.

2. When the prompt <F1> Setup is displayed, press F1. If you have set an administrator password, you must type the administrator password to access the full Setup utility menu. If you do not type the administrator password, a limited Setup utility menu is available.
3. Select **System Settings** → **Adapters and UEFI drivers**.
4. Press Enter to refresh the list of device drivers.
5. Select the device driver for your RAID controller and press Enter.
6. Follow the instructions in the documentation for your RAID controllers.

Using the IBM Advanced Settings Utility program

The IBM Advanced Settings Utility (ASU) is an alternative to the Setup utility for modifying UEFI settings. Use the ASU online or out of band to modify UEFI settings from the command line without the need to restart the server to access the Setup utility.

You can also use the ASU to configure the optional remote presence feature or other iBMC settings. The remote presence feature provides enhanced systems-management capabilities.

In addition, the ASU provides limited settings for configuring the IPMI function in the iBMC through the command-line interface.

Use the command-line interface to issue setup commands. You can save any of the settings as a file and run the file as a script. The ASU supports scripting environments through a batch-processing mode.

For more information and to download the ASU and the *Advanced Settings Utility User's Guide*, go to <http://www.ibm.com/support/entry/portal/docdisplay?brand=5000008&Indocid=TOOL-ASU>.

Updating IBM Systems Director

If you plan to use IBM Systems Director to manage the server, you must check for the latest applicable IBM Systems Director updates and interim fixes.

Note: Changes are made periodically to the IBM website. The actual procedure might vary slightly from what is described in this document.

To locate and install a newer version of IBM Systems Director, complete the following steps:

1. Check for the latest version of IBM Systems Director:
 - a. Go to <http://www-03.ibm.com/systems/software/director/downloads/>.
 - b. If a newer version of IBM Systems Director than what comes with the server is shown in the drop-down list, follow the instructions on the web page to download the latest version.
2. Install the IBM Systems Director program.

If your management server is connected to the Internet, to locate and install updates and interim fixes, complete the following steps:

1. Make sure that you have run the Discovery and Inventory collection tasks.
2. On the Welcome page of the IBM Systems Director web interface, click **View updates**.
3. Click **Check for updates**. The available updates are displayed in a table.
4. Select the updates that you want to install, and click **Install** to start the installation wizard.

If your management server is not connected to the Internet, to locate and install updates and interim fixes, complete the following steps:

1. Make sure that you have run the Discovery and Inventory collection tasks.
2. On a system that is connected to the Internet, go to <http://www.ibm.com/eserver/support/fixes/fixcentral/>.
3. From the **Product family** list, select **IBM Systems Director**.
4. From the **Product** list, select **IBM Systems Director**.
5. From the **Installed version** list, select the latest version, and click **Continue**.
6. Download the available updates.
7. Copy the downloaded files to the management server.
8. On the management server, on the Welcome page of the IBM Systems Director web interface, click the **Manage** tab, and click **Update Manager**.
9. Click **Import updates** and specify the location of the downloaded files that you copied to the management server.
10. Return to the Welcome page of the web interface, and click **View updates**.
11. Select the updates that you want to install, and click **Install** to start the installation wizard.

Appendix A. Getting help and technical assistance

If you need help, service, or technical assistance or just want more information about IBM products, you will find a wide variety of sources available from IBM to assist you. Use this information to obtain additional information about IBM and IBM products, determine what to do if you experience a problem with your IBM system or optional device, and determine whom to call for service, if it is necessary.

Before you call

Before you call, make sure that you have taken these steps to try to solve the problem yourself:

- Check all cables to make sure that they are connected.
- Check the power switches to make sure that the system and any optional devices are turned on.
- Check for updated firmware and operating-system device drivers for your IBM product. The IBM Warranty terms and conditions state that you, the owner of the IBM product, are responsible for maintaining and updating all software and firmware for the product (unless it is covered by an additional maintenance contract). Your IBM service technician will request that you upgrade your software and firmware if the problem has a documented solution within a software upgrade.
- If you have installed new hardware or software in your environment, check <http://www.ibm.com/systems/info/x86servers/serverproven/compat/us/> to make sure that the hardware and software is supported by your IBM product.
- Go to <http://www.ibm.com/supportportal/> to check for information to help you solve the problem.
- Gather the following information to provide to IBM Support. This data will help IBM Support quickly provide a solution to your problem and ensure that you receive the level of service for which you might have contracted.
 - Hardware and Software Maintenance agreement contract numbers, if applicable
 - Machine type number (IBM 4-digit machine identifier)
 - Model number
 - Serial number
 - Current system UEFI and firmware levels
 - Other pertinent information such as error messages and logs
- Go to http://www.ibm.com/support/entry/portal/Open_service_request/ to submit an Electronic Service Request. Submitting an Electronic Service Request will start the process of determining a solution to your problem by making the pertinent information available to IBM Support quickly and efficiently. IBM service technicians can start working on your solution as soon as you have completed and submitted an Electronic Service Request.

You can solve many problems without outside assistance by following the troubleshooting procedures that IBM provides in the online help or in the documentation that is provided with your IBM product. The documentation that comes with IBM systems also describes the diagnostic tests that you can perform. Most systems, operating systems, and programs come with documentation that

contains troubleshooting procedures and explanations of error messages and error codes. If you suspect a software problem, see the documentation for the operating system or program.

Using the documentation

Information about your IBM system and preinstalled software, if any, or optional device is available in the documentation that comes with the product. That documentation can include printed documents, online documents, readme files, and help files. See the troubleshooting information in your system documentation for instructions for using the diagnostic programs. The troubleshooting information or the diagnostic programs might tell you that you need additional or updated device drivers or other software. IBM maintains pages on the World Wide Web where you can get the latest technical information and download device drivers and updates. To access these pages, go to <http://www.ibm.com/supportportal/>. Also, some documents are available through the IBM Publications Center at <http://www.ibm.com/shop/publications/order/>.

Getting help and information from the World Wide Web

On the World Wide Web, up-to-date information about IBM systems, optional devices, services, and support is available at <http://www.ibm.com/supportportal/>. The address for IBM System x information is <http://www.ibm.com/systems/x/>. The address for IBM BladeCenter[®] information is <http://www.ibm.com/systems/bladecenter/>. The address for IBM IntelliStation[®] information is <http://www.ibm.com/systems/intellistation/>.

How to send Dynamic System Analysis data to IBM

Use the IBM Enhanced Customer Data Repository to send diagnostic data to IBM. Before you send diagnostic data to IBM, read the terms of use at <http://www.ibm.com/de/support/ecurep/terms.html>.

You can use any of the following methods to send diagnostic data to IBM:

- **Standard upload:** http://www.ibm.com/de/support/ecurep/send_http.html
- **Standard upload with the system serial number:** http://www.ecurep.ibm.com/app/upload_hw
- **Secure upload:** http://www.ibm.com/de/support/ecurep/send_http.html#secure
- **Secure upload with the system serial number:** https://www.ecurep.ibm.com/app/upload_hw

Creating a personalized support web page

At <http://www.ibm.com/support/mynotifications/>, you can create a personalized support web page by identifying IBM products that are of interest to you. From this personalized page, you can subscribe to weekly email notifications about new technical documents, search for information and downloads, and access various administrative services.

Software service and support

Through IBM Support Line, you can get telephone assistance, for a fee, with usage, configuration, and software problems with your IBM products. For information about which products are supported by Support Line in your country or region, see <http://www.ibm.com/services/supline/products/>.

For more information about Support Line and other IBM services, see <http://www.ibm.com/services/>, or see <http://www.ibm.com/planetwide/> for support telephone numbers. In the U.S. and Canada, call 1-800-IBM-SERV (1-800-426-7378).

Hardware service and support

You can receive hardware service through your IBM reseller or IBM Services. To locate a reseller authorized by IBM to provide warranty service, go to <http://www.ibm.com/partnerworld/> and click **Find Business Partners** on the right side of the page. For IBM support telephone numbers, see <http://www.ibm.com/planetwide/>. In the U.S. and Canada, call 1-800-IBM-SERV (1-800-426-7378).

In the U.S. and Canada, hardware service and support is available 24 hours a day, 7 days a week. In the U.K., these services are available Monday through Friday, from 9 a.m. to 6 p.m.

IBM Taiwan product service

台灣 IBM 產品服務聯絡方式：
台灣國際商業機器股份有限公司
台北市松仁路7號3樓
電話：0800-016-888

IBM Taiwan product service contact information:
IBM Taiwan Corporation
3F, No 7, Song Ren Rd.
Taipei, Taiwan
Telephone: 0800-016-888

Appendix B. Notices

This information was developed for products and services offered in the U.S.A.

IBM may not offer the products, services, or features discussed in this document in other countries. Consult your local IBM representative for information on the products and services currently available in your area. Any reference to an IBM product, program, or service is not intended to state or imply that only that IBM product, program, or service may be used. Any functionally equivalent product, program, or service that does not infringe any IBM intellectual property right may be used instead. However, it is the user's responsibility to evaluate and verify the operation of any non-IBM product, program, or service.

IBM may have patents or pending patent applications covering subject matter described in this document. The furnishing of this document does not give you any license to these patents. You can send license inquiries, in writing, to:

*IBM Director of Licensing
IBM Corporation
North Castle Drive
Armonk, NY 10504-1785
U.S.A.*

INTERNATIONAL BUSINESS MACHINES CORPORATION PROVIDES THIS PUBLICATION "AS IS" WITHOUT WARRANTY OF ANY KIND, EITHER EXPRESS OR IMPLIED, INCLUDING, BUT NOT LIMITED TO, THE IMPLIED WARRANTIES OF NON-INFRINGEMENT, MERCHANTABILITY OR FITNESS FOR A PARTICULAR PURPOSE. Some states do not allow disclaimer of express or implied warranties in certain transactions, therefore, this statement may not apply to you.

This information could include technical inaccuracies or typographical errors. Changes are periodically made to the information herein; these changes will be incorporated in new editions of the publication. IBM may make improvements and/or changes in the product(s) and/or the program(s) described in this publication at any time without notice.

Any references in this information to non-IBM websites are provided for convenience only and do not in any manner serve as an endorsement of those websites. The materials at those websites are not part of the materials for this IBM product, and use of those websites is at your own risk.

IBM may use or distribute any of the information you supply in any way it believes appropriate without incurring any obligation to you.

Trademarks

IBM, the IBM logo, and [ibm.com](http://www.ibm.com) are trademarks of International Business Machines Corp., registered in many jurisdictions worldwide. Other product and service names might be trademarks of IBM or other companies. A current list of IBM trademarks is available on the web at "Copyright and trademark information" at <http://www.ibm.com/legal/copytrade.shtml>.

Adobe and PostScript are either registered trademarks or trademarks of Adobe Systems Incorporated in the United States and/or other countries.

Cell Broadband Engine is a trademark of Sony Computer Entertainment, Inc., in the United States, other countries, or both and is used under license therefrom.

Intel, Intel Xeon, Itanium, and Pentium are trademarks or registered trademarks of Intel Corporation or its subsidiaries in the United States and other countries.

Java and all Java-based trademarks and logos are trademarks or registered trademarks of Oracle and/or its affiliates.

Linux is a registered trademark of Linus Torvalds in the United States, other countries, or both.

Microsoft, Windows, and Windows NT are trademarks of Microsoft Corporation in the United States, other countries, or both.

UNIX is a registered trademark of The Open Group in the United States and other countries.

Important notes

Processor speed indicates the internal clock speed of the microprocessor; other factors also affect application performance.

CD or DVD drive speed is the variable read rate. Actual speeds vary and are often less than the possible maximum.

When referring to processor storage, real and virtual storage, or channel volume, KB stands for 1024 bytes, MB stands for 1,048,576 bytes, and GB stands for 1,073,741,824 bytes.

When referring to hard disk drive capacity or communications volume, MB stands for 1,000,000 bytes, and GB stands for 1,000,000,000 bytes. Total user-accessible capacity can vary depending on operating environments.

Maximum internal hard disk drive capacities assume the replacement of any standard hard disk drives and population of all hard disk drive bays with the largest currently supported drives that are available from IBM.

Maximum memory might require replacement of the standard memory with an optional memory module.

Each solid-state memory cell has an intrinsic, finite number of write cycles that the cell can incur. Therefore, a solid-state device has a maximum number of write cycles that it can be subjected to, expressed as “total bytes written” (TBW). A device that has exceeded this limit might fail to respond to system-generated commands or might be incapable of being written to. IBM is not responsible for replacement of a device that has exceeded its maximum guaranteed number of program/erase cycles, as documented in the Official Published Specifications for the device.

IBM makes no representation or warranties regarding non-IBM products and services that are ServerProven[®], including but not limited to the implied warranties of merchantability and fitness for a particular purpose. These products are offered and warranted solely by third parties.

IBM makes no representations or warranties with respect to non-IBM products. Support (if any) for the non-IBM products is provided by the third party, not IBM.

Some software might differ from its retail version (if available) and might not include user manuals or all program functionality.

Battery return program

This product may contain a sealed lead acid, nickel cadmium, nickel metal hydride, lithium, or lithium ion battery. Consult your user manual or service manual for specific battery information. The battery must be recycled or disposed of properly. Recycling facilities may not be available in your area. For information on disposal of batteries outside the United States, go to <http://www.ibm.com/ibm/environment/products/index.shtml> or contact your local waste disposal facility.

In the United States, IBM has established a return process for reuse, recycling, or proper disposal of used IBM sealed lead acid, nickel cadmium, nickel metal hydride, and battery packs from IBM equipment. For information on proper disposal of these batteries, contact IBM at 1-800-426-4333. Have the IBM part number listed on the battery available prior to your call.

For Taiwan: Please recycle batteries.



For the European Union:

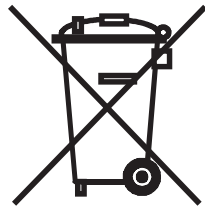

Notice: This mark applies only to countries within the European Union (EU).

Batteries or packaging for batteries are labeled in accordance with European Directive 2006/66/EC concerning batteries and accumulators and waste batteries and accumulators. The Directive determines the framework for the return and recycling of used batteries and accumulators as applicable throughout the European Union. This label is applied to various batteries to indicate that the battery is not to be thrown away, but rather reclaimed upon end of life per this Directive.

Les batteries ou emballages pour batteries sont étiquetés conformément aux directives européennes 2006/66/EC, norme relative aux batteries et accumulateurs en usage et aux batteries et accumulateurs usés. Les directives déterminent la marche à suivre en vigueur dans l'Union Européenne pour le retour et le recyclage des batteries et accumulateurs usés. Cette étiquette est appliquée sur diverses

batteries pour indiquer que la batterie ne doit pas être mise au rebut mais plutôt récupérée en fin de cycle de vie selon cette norme.

バッテリーあるいはバッテリー用のパッケージには、EU 諸国に対する廃電気電子機器指令 2006/66/EC のラベルが貼られています。この指令は、バッテリーと蓄電池、および廃棄バッテリーと蓄電池に関するものです。この指令は、使用済みバッテリーと蓄電池の回収とリサイクルの骨子を定めているもので、EU 諸国にわたって適用されます。このラベルは、使用済みになったときに指令に従って適正な処理をする必要があることを知らせるために種々のバッテリーに貼られています。

In accordance with the European Directive 2006/66/EC, batteries and accumulators are labeled to indicate that they are to be collected separately and recycled at end of life. The label on the battery may also include a chemical symbol for the metal concerned in the battery (Pb for lead, Hg for mercury, and Cd for cadmium). Users of batteries and accumulators must not dispose of batteries and accumulators as unsorted municipal waste, but use the collection framework available to customers for the return, recycling, and treatment of batteries and accumulators. Customer participation is important to minimize any potential effects of batteries and accumulators on the environment and human health due to the potential presence of hazardous substances. For proper collection and treatment, contact your local IBM representative.

This notice is provided in accordance with Royal Decree 106/2008 of Spain: The retail price of batteries, accumulators, and power cells includes the cost of the environmental management of their waste.

For California:

Perchlorate material – special handling may apply. See <http://www.dtsc.ca.gov/hazardouswaste/perchlorate/>.

The foregoing notice is provided in accordance with California Code of Regulations Title 22, Division 4.5 Chapter 33. Best Management Practices for Perchlorate Materials. This product/part may include a lithium manganese dioxide battery which contains a perchlorate substance.

German Ordinance for Work gloss statement

The product is not suitable for use with visual display work place devices according to clause 2 of the German Ordinance for Work with Visual Display Units.

Das Produkt ist nicht für den Einsatz an Bildschirmarbeitsplätzen im Sinne § 2 der Bildschirmarbeitsverordnung geeignet.

Particulate contamination

Attention: Airborne particulates (including metal flakes or particles) and reactive gases acting alone or in combination with other environmental factors such as humidity or temperature might pose a risk to the server that is described in this document. Risks that are posed by the presence of excessive particulate levels or concentrations of harmful gases include damage that might cause the server to malfunction or cease functioning altogether. This specification sets forth limits for particulates and gases that are intended to avoid such damage. The limits must not be viewed or used as definitive limits, because numerous other factors, such as temperature or moisture content of the air, can influence the impact of particulates or environmental corrosives and gaseous contaminant transfer. In the absence of specific limits that are set forth in this document, you must implement practices that maintain particulate and gas levels that are consistent with the protection of human health and safety. If IBM determines that the levels of particulates or gases in your environment have caused damage to the server, IBM may condition provision of repair or replacement of servers or parts on implementation of appropriate remedial measures to mitigate such environmental contamination. Implementation of such remedial measures is a customer responsibility.

Table 6. Limits for particulates and gases

Contaminant	Limits
Particulate	<ul style="list-style-type: none">The room air must be continuously filtered with 40% atmospheric dust spot efficiency (MERV 9) according to ASHRAE Standard 52.2¹.Air that enters a data center must be filtered to 99.97% efficiency or greater, using high-efficiency particulate air (HEPA) filters that meet MIL-STD-282.The deliquescent relative humidity of the particulate contamination must be more than 60%².The room must be free of conductive contamination such as zinc whiskers.
Gaseous	<ul style="list-style-type: none">Copper: Class G1 as per ANSI/ISA 71.04-1985³Silver: Corrosion rate of less than 300 Å in 30 days

¹ ASHRAE 52.2-2008 - *Method of Testing General Ventilation Air-Cleaning Devices for Removal Efficiency by Particle Size*. Atlanta: American Society of Heating, Refrigerating and Air-Conditioning Engineers, Inc.

² The deliquescent relative humidity of particulate contamination is the relative humidity at which the dust absorbs enough water to become wet and promote ionic conduction.

³ ANSI/ISA-71.04-1985. *Environmental conditions for process measurement and control systems: Airborne contaminants*. Instrument Society of America, Research Triangle Park, North Carolina, U.S.A.

Documentation format

The publications for this product are in Adobe Portable Document Format (PDF) and should be compliant with accessibility standards. If you experience difficulties when you use the PDF files and want to request a web-based format or accessible PDF document for a publication, direct your mail to the following address:

*Information Development
IBM Corporation
205/A015
3039 E. Cornwallis Road
P.O. Box 12195
Research Triangle Park, North Carolina 27709-2195*

U.S.A.

In the request, be sure to include the publication part number and title.

When you send information to IBM, you grant IBM a nonexclusive right to use or distribute the information in any way it believes appropriate without incurring any obligation to you.

Telecommunication regulatory statement

This product may not be certified in your country for connection by any means whatsoever to interfaces of public telecommunications networks. Further certification may be required by law prior to making any such connection. Contact an IBM representative or reseller for any questions.

Electronic emission notices

When you attach a monitor to the equipment, you must use the designated monitor cable and any interference suppression devices that are supplied with the monitor.

Federal Communications Commission (FCC) statement

Note: This equipment has been tested and found to comply with the limits for a Class A digital device, pursuant to Part 15 of the FCC Rules. These limits are designed to provide reasonable protection against harmful interference when the equipment is operated in a commercial environment. This equipment generates, uses, and can radiate radio frequency energy and, if not installed and used in accordance with the instruction manual, may cause harmful interference to radio communications. Operation of this equipment in a residential area is likely to cause harmful interference, in which case the user will be required to correct the interference at his own expense.

Properly shielded and grounded cables and connectors must be used in order to meet FCC emission limits. IBM is not responsible for any radio or television interference caused by using other than recommended cables and connectors or by unauthorized changes or modifications to this equipment. Unauthorized changes or modifications could void the user's authority to operate the equipment.

This device complies with Part 15 of the FCC Rules. Operation is subject to the following two conditions: (1) this device may not cause harmful interference, and (2) this device must accept any interference received, including interference that may cause undesired operation.

Industry Canada Class A emission compliance statement

This Class A digital apparatus complies with Canadian ICES-003.

Avis de conformité à la réglementation d'Industrie Canada

Cet appareil numérique de la classe A est conforme à la norme NMB-003 du Canada.

Australia and New Zealand Class A statement

Attention: This is a Class A product. In a domestic environment this product may cause radio interference in which case the user may be required to take adequate measures.

European Union EMC Directive conformance statement

This product is in conformity with the protection requirements of EU Council Directive 2004/108/EC on the approximation of the laws of the Member States relating to electromagnetic compatibility. IBM cannot accept responsibility for any failure to satisfy the protection requirements resulting from a nonrecommended modification of the product, including the fitting of non-IBM option cards.

Attention: This is an EN 55022 Class A product. In a domestic environment this product may cause radio interference in which case the user may be required to take adequate measures.

Responsible manufacturer:
International Business Machines Corp.
New Orchard Road
Armonk, New York 10504
914-499-1900

European Community contact:
IBM Deutschland GmbH
Technical Regulations, Department M372
IBM-Allee 1, 71139 Ehningen, Germany
Telephone: +49 7032 15 2941
Email: lugi@de.ibm.com

Germany Class A statement

Deutschsprachiger EU Hinweis:

Hinweis für Geräte der Klasse A EU-Richtlinie zur Elektromagnetischen Verträglichkeit

Dieses Produkt entspricht den Schutzanforderungen der EU-Richtlinie 2004/108/EG zur Angleichung der Rechtsvorschriften über die elektromagnetische Verträglichkeit in den EU-Mitgliedsstaaten und hält die Grenzwerte der EN 55022 Klasse A ein.

Um dieses sicherzustellen, sind die Geräte wie in den Handbüchern beschrieben zu installieren und zu betreiben. Des Weiteren dürfen auch nur von der IBM empfohlene Kabel angeschlossen werden. IBM übernimmt keine Verantwortung für die Einhaltung der Schutzanforderungen, wenn das Produkt ohne Zustimmung der IBM verändert bzw. wenn Erweiterungskomponenten von Fremdherstellern ohne Empfehlung der IBM gesteckt/eingebaut werden.

EN 55022 Klasse A Geräte müssen mit folgendem Warnhinweis versehen werden: "Warnung: Dieses ist eine Einrichtung der Klasse A. Diese Einrichtung kann im Wohnbereich Funk-Störungen verursachen; in diesem Fall kann vom Betreiber verlangt werden, angemessene Maßnahmen zu ergreifen und dafür aufzukommen."

Deutschland: Einhaltung des Gesetzes über die elektromagnetische Verträglichkeit von Geräten

Dieses Produkt entspricht dem "Gesetz über die elektromagnetische Verträglichkeit von Geräten (EMVG)". Dies ist die Umsetzung der EU-Richtlinie 2004/108/EG in der Bundesrepublik Deutschland.

Zulassungsbescheinigung laut dem Deutschen Gesetz über die elektromagnetische Verträglichkeit von Geräten (EMVG) (bzw. der EMC EG Richtlinie 2004/108/EG) für Geräte der Klasse A

Dieses Gerät ist berechtigt, in Übereinstimmung mit dem Deutschen EMVG das EG-Konformitätszeichen - CE - zu führen.

Verantwortlich für die Einhaltung der EMV Vorschriften ist der Hersteller:

International Business Machines Corp.
New Orchard Road
Armonk, New York 10504
914-499-1900

Der verantwortliche Ansprechpartner des Herstellers in der EU ist:

IBM Deutschland GmbH
Technical Regulations, Abteilung M372
IBM-Allee 1, 71139 Ehningen, Germany
Telephone: +49 7032 15 2941
Email: lugi@de.ibm.com

Generelle Informationen:

Das Gerät erfüllt die Schutzanforderungen nach EN 55024 und EN 55022 Klasse A.

VCCI Class A statement

この装置は、クラス A 情報技術装置です。この装置を家庭環境で使用すると電波妨害を引き起こすことがあります。この場合には使用者が適切な対策を講ずるよう要求されることがあります。 VCCI-A

This is a Class A product based on the standard of the Voluntary Control Council for Interference (VCCI). If this equipment is used in a domestic environment, radio interference may occur, in which case the user may be required to take corrective actions.

Japan Electronics and Information Technology Industries Association (JEITA) statement

高調波ガイドライン適合品

Japanese Electronics and Information Technology Industries Association (JEITA)
Confirmed Harmonics Guideline (products less than or equal to 20 A per phase)

Korea Communications Commission (KCC) statement

이 기기는 업무용(A급)으로 전자파적합기기로서 판매자 또는 사용자는 이 점을 주의하시기 바라며, 가정외의 지역에서 사용하는 것을 목적으로 합니다.

This is electromagnetic wave compatibility equipment for business (Type A). Sellers and users need to pay attention to it. This is for any areas other than home.

Russia Electromagnetic Interference (EMI) Class A statement

ВНИМАНИЕ! Настоящее изделие относится к классу А.
В жилых помещениях оно может создавать радиопомехи, для
снижения которых необходимы дополнительные меры

People's Republic of China Class A electronic emission statement

中华人民共和国“A类”警告声明

声明

此为A级产品，在生活环境中，该产品可能会造成无线电干扰。在这种情况下，
可能需要用户对其干扰采取切实可行的措施。

Taiwan Class A compliance statement

警告使用者：
這是甲類的資訊產品，在
居住的環境中使用時，可
能會造成射頻干擾，在這
種情況下，使用者會被要
求採取某些適當的對策。

Index

A

- ac power LED 17
- accessible documentation 99
- adapter
 - PCI bus, identification 43
 - slot types 43
- administrator password 80
- Advanced Settings Utility 88
- air baffle 41
 - installing 71
 - removing 41
- assistance, getting 91
- ASU 88
- attention notices 4
- Automatic BIOS recovery for UEFI 11
- availability 11

B

- battery
 - return program 97
- bays 6
- before you install a UEFI operating system 84
- blue-screen capture feature, overview 87
- boot manager 80
- boot selection menu program, using 82
- booting a legacy operating-system CD 84

C

- cable routing
 - external 74
 - internal 33, 34, 35
- cabling
 - external 74
 - the server 74
- caution statements 4
- CD, documentation 2
- Checkpoint code display 15
- Class A electronic emission notice 100
- completing the installation 70
- components 23
- configuration
 - updating 74
 - updating server 77
 - with ServerGuide 84
- configuring, RAID arrays 88
- connecting the cables 74
- connectors
 - DIMM 25
 - front of server 13
 - rear of server 16
 - system board 24, 26
- contamination, particulate and gaseous 6, 99
- controller, configuring Ethernet 87
- controls 13

- controls and LEDs
 - on light path diagnostics panel 14
 - operator information panel 14
- cooling 6
- cover
 - installing 73

D

- danger statements 4
- date and time 80
- dc power LED 17
- device drivers 12
- devices and I/O ports 79
- diagnostic data 92
- diagnostics panel, controls and LEDs 14
- dimensions 6
- DIMM
 - speed 63
- DIMMs
 - supported 63
- documentation
 - updates 1
- documentation CD
 - hardware and software requirements 2
 - using 2
- documentation format 99
- DVD
 - drive activity LED 13
 - eject button 13
- DVD drive, installing 58
- Dynamic System Analysis 92

E

- electrical input 6
- electronic emission Class A notice 100
- environment 6
- Ethernet
 - activity LED 14
 - connectors 16
 - controller configuration 78
 - controller, configuring 87
 - Gigabit controller 10
 - icon LED 14
- Ethernet activity LED 17
- Ethernet over USB 79
- Ethernet-link LED 17
- Ethernet-link status LED 14
- expansion bays 6
- expansion slots, PCI adapter 42
- external cabling 74

F

- fan door 39
- fans 6

- FCC Class A notice 100
- features 4
 - iBMC 85
 - remote presence 87
 - ServerGuide 83
- filler panel, hard disk drive bay 55, 56
- firmware
 - server 77
 - UEFI-compliant 8
 - updates 82
- firmware updates 1, 30
- force legacy video on boot 79
- front view 13

G

- gaseous contamination 6, 99
- getting help 91
- gigabit Ethernet controller, configuring 87
- gloss statement (Germany) 98
- guidelines
 - installation 30
 - system reliability 31

H

- handling static-sensitive devices 32
- hard disk drive
 - filler panel 55, 56
 - installing 55, 56
 - status LED 13
 - support 10
- hardware service and support 93
- heat output 6
- help, getting 91
- hot-swap and hot-plug devices
 - hard disk drive 55
- humidity 6

I

- IBM Support Line 92
- IBM Systems Director 8
 - overview 12
 - updating 88
- iBMC 8
 - using 85
- IMM 79
- important notices 4
- information LED 14
- input/output connectors 74
- installation guidelines 30
- installing
 - air baffle 71
 - cover 73
 - DVD drive 58
 - hard disk drive 55, 56
 - hot-swap hard disk drive 55
 - hot-swap power supply 54
 - internal removable flash drive 61
 - memory 65

- installing (*continued*)
 - memory modules 65
 - microprocessor 66
 - optional devices 21
 - PCI adapter 42
 - PCI riser-card assembly 70
 - ServeRAID adapter advanced feature key 52
 - ServeRAID controller 45
 - ServeRAID controller battery 47
 - simple-swap hard disk drive 56
 - tape drive 59
 - top cover 73
- integrated
 - functions 6
 - network support 10
- integrated baseboard management controller 8, 85
- integrated management module
 - settings 79
- internal cabling
 - backplane signal cables 33
 - backplane signal cable 34, 35
 - DVD cable 36
 - power-supply distribution board 38
 - USB hypervisor key 37
- internal removable flash drive 61
- IP address, obtaining for web interface 86

J

- jumpers
 - system board 27

L

- LED
 - ac power 17
 - dc power 17
 - power-supply detected problems 17
- LEDs 13
 - Ethernet activity 14, 17
 - Ethernet icon 14
 - Ethernet link 17
 - Ethernet-link status 14
 - front of server 13
 - information 14
 - locator 14, 17
 - power-on 14
 - power-supply 17
 - rear 17
 - system board 29
 - system error 14
 - system-error 17
- LEDs and controls
 - on light path diagnostics panel 14
 - operator information panel 14
- legacy operating system
 - requirement 84
- light path button 26
- light path diagnostics 10
- light path diagnostics button 29
- light path diagnostics panel, accessing 14

limitations, single power supply 31
local area network (LAN) 10
locator LED 14

M

management, systems 8
memory 9, 79
 installation sequence
 non-sparing mode 64
 online-sparing mode 64
 specifications 6
 speed 63
 supported 63
memory online-spare
 description 64
microprocessor 8
 installation 66
 installing
 applying thermal grease 69
 settings 79
 specifications 6
microprocessor socket dust cover 67

N

network configuration 79
NMI button 15
noise emissions 6
notes 4
notes, important 96
notices 95
 electronic emission 100
 FCC, Class A 100
notices and statements 4

O

obtaining IP address for web interface 86
online-spare mode 64
operating system 21
operating system installation
 with ServerGuide 84
 without ServerGuide 85
optical drives 6
options, installing 21

P

particulate contamination 6, 99
password
 administrator 81
 power-on 81
passwords 80
PCI adapter
 installing 42
PCI expansion slots 6, 42
PCI riser-card assembly 40
 installing 70
 removing 40

PCI slots 6
power
 features 18
 requirement 6
power settings 79
power supply
 hot-swap 53
 installing 53, 54
 specification 6
power-control button 14
power-cord connector 16
power-error LED 17
power-on LED, front 14
power-on password 80
power-supply
 LEDs 17
 LEDs and detected problems 17
processor 79
product data 79
public services network, use in 100
public telecommunications network, connection to 100
publications 3

R

RAID 6
RAID arrays, configuring 88
RAS features 11
rear
 LEDs 17
rear view 16
redundant power 10
rehook INT 79
related publications 3
reliability 11
remind button 15
remote presence feature, using 87
removing
 air baffle 41
 PCI riser-card assembly 40
 top cover 39
 top-cover fan door 39
replacing
 tape drive 59
reset button 16

S

safety information
 Statement 13 xiii
 Statement 15 xiv
security 80
serial
 connector 16
 number location 2
server
 components 23
 firmware, starting backup 82
 firmware, UEFI-compliant 8
server configuration, updating 77
ServeRAID 10

- ServeRAID adapter advanced feature key
 - installing 52
- ServeRAID controller
 - installing 45
- ServeRAID controller battery
 - installing 47
- ServerGuide
 - features 83
 - Setup and Installation CD 10
 - using 83
 - using to install operating system 84
- ServerProven 2, 21, 30
- serviceability 11
- setup and configuration with ServerGuide 84
- Setup utility 78
 - starting 78
 - using 78
- simple-swap and hot-plug devices
 - hard disk drive 56
- size 6
- SMP description 8
- software service and support 92
- specifications 4
- Standby mode 18
- start options 80
- starting
 - backup server firmware 82
 - Setup utility 78
- startup sequence 80
- statements and notices 4
- static-sensitive devices, handling 32
- supported optional devices 31
- symmetric multiprocessing 8
- system board
 - DIMM connectors 25
 - external connectors 26
 - internal connectors 24
 - jumpers 27
 - LEDs 29
 - light path button 26
- system information 78
- system reliability guidelines 31
- system settings 79
- system summary 78
- system-board jumpers 27
- system-error LED, front 14
- system-locator LED 14
- system-management connector 16
- Systems Director, updating 88
- systems management 8, 12

T

- tape drive
 - installing 59
- telephone numbers 93
- temperature 6
- thermal grease 69
 - applying 69
- time and date 80
- ToolsCenter 4

- ToolsCenter for System x and BladeCenter 30
- top cover 39
 - installing 73
 - removing 39
- top-cover
 - fan door 39
- top-cover fan door
 - removing 39
- trademarks 95
- turning off the server 18
- turning on the server 18
- TÜV gloss statement 98

U

- UEFI 78, 88
- UEFI operating system
 - requirement 84
- United States electronic emission Class A notice 100
- United States FCC Class A notice 100
- UpdateXpress 12
- updating
 - IBM Systems Director 88
 - server configuration 74, 77
- USB connectors 16
- user security 80
- using
 - boot selection menu program 82
 - remote presence feature 87
 - ServerGuide 83
 - Setup utility 78
- UXSPI 12

V

- video
 - force legacy video on boot 79
- video connector 16

W

- web interface
 - logging on to 86
- Web interface
 - obtaining IP address 86
- website
 - personalized support 92
 - publication ordering 92
 - ServerGuide 83
 - support line, telephone numbers 93
- weight 6



Part Number: 46W8137

Printed in USA

(1P) P/N: 46W8137

