

IBM System x3500 Type 7977



User's Guide

IBM System x3500 Type 7977



User's Guide

Note: Before using this information and the product it supports, read the general information in "Notices," on page 81 and the *Warranty and Support Information* document on the IBM System x Documentation CD.

Fifth Edition (October 2008)

© Copyright International Business Machines Corporation 2008.

US Government Users Restricted Rights – Use, duplication or disclosure restricted by GSA ADP Schedule Contract with IBM Corp.

Contents

Safety	v
Chapter 1. The System x3500 server	1
Related documentation	1
Notices and statements in this document	2
Features and specifications	3
What your server offers	4
Reliability, availability, and serviceability	5
IBM Director	6
The UpdateXpress program	7
Front view	8
Rear view	10
Server power features	11
Turning on the server	11
Turning off the server	11
Chapter 2. Installing optional devices.	13
Server components	13
System-board internal connectors and switches	14
System-board LEDs	15
System-board external connectors	16
Light path diagnostics panel	16
Installation guidelines	21
System reliability guidelines	22
Working inside the server with the power on	22
Handling static-sensitive devices	22
Removing the bezel	23
Removing the left-side cover	24
Installing an adapter	24
Installing the optional IBM ServeRAID-MR10is VAULT SAS/SATA Controller	27
Installing a DVD drive	31
Installing a full-high tape drive	32
Installing a USB tape drive	33
Installing a hot-swap hard disk drive	34
Installing an IBM Remote Supervisor Adapter II SlimLine	35
Installing a memory module	37
Installing a microprocessor	43
Installing redundant power and cooling	45
Completing the installation.	49
Connecting the cables	50
Updating the server configuration	50
Chapter 3. Configuring the server	53
Using the Configuration/Setup Utility program	54
Starting the Configuration/Setup Utility program	54
Configuration/Setup Utility menu choices	54
Passwords	58
Using the ServerGuide Setup and Installation CD	59
ServerGuide features	60
Setup and configuration overview	60
Typical operating system installation	61
Installing your operating system without ServerGuide	61
Using the baseboard management controller	61

Enabling and configuring SOL using the OSA SMBridge management utility program	62
Installing the OSA SMBridge management utility program	70
Using the baseboard management controller utility programs	72
Using the Boot Menu program	73
Enabling the Broadcom Gigabit Ethernet Utility program	73
Configuring the Broadcom Gigabit Ethernet controller	74
Setting up the Remote Supervisor Adapter II SlimLine	74
Requirements	74
Cabling the Remote Supervisor Adapter II SlimLine	75
Installing the Remote Supervisor Adapter II SlimLine firmware	75
Completing the setup	76
Using the Adaptec RAID Configuration Utility program	76
Starting the Adaptec RAID Configuration Utility program	76
Adaptec RAID Configuration Utility menu choices	77
Creating a RAID array	77
Viewing the array configuration	77
Using ServeRAID Manager	77
Configuring the controller	78
Viewing the configuration	79
Updating IBM Director	79
Appendix. Notices	81
Trademarks	81
Important notes.	82
Product recycling and disposal	83
Battery return program	84
Electronic emission notices	85
Federal Communications Commission (FCC) statement	85
Industry Canada Class A emission compliance statement	86
Avis de conformité à la réglementation d'Industrie Canada	86
Australia and New Zealand Class A statement	86
United Kingdom telecommunications safety requirement.	86
European Union EMC Directive conformance statement	86
Taiwanese Class A warning statement	87
Chinese Class A warning statement	87
Japanese Voluntary Control Council for Interference (VCCI) statement	87
Index	89

Safety

Before installing this product, read the Safety Information.

قبل تركيب هذا المنتج، يجب قراءة الملاحظات الأمنية

Antes de instalar este produto, leia as Informações de Segurança.

在安装本产品之前，请仔细阅读 **Safety Information** (安全信息)。

安裝本產品之前，請先閱讀「安全資訊」。

Prije instalacije ovog produkta obavezno pročitajte Sigurnosne Upute.

Před instalací tohoto produktu si přečtěte příručku bezpečnostních instrukcí.

Læs sikkerhedsforskrifterne, før du installerer dette produkt.

Lees voordat u dit product installeert eerst de veiligheidsvoorschriften.

Ennen kuin asennat tämän tuotteen, lue turvaohjeet kohdasta Safety Information.

Avant d'installer ce produit, lisez les consignes de sécurité.

Vor der Installation dieses Produkts die Sicherheitshinweise lesen.

Πριν εγκαταστήσετε το προϊόν αυτό, διαβάστε τις πληροφορίες ασφαλείας (safety information).

לפני שתתקינו מוצר זה, קראו את הוראות הבטיחות.

A termék telepítése előtt olvassa el a Biztonsági előírásokat!

Prima di installare questo prodotto, leggere le Informazioni sulla Sicurezza.

製品の設置の前に、安全情報をお読みください。

본 제품을 설치하기 전에 안전 정보를 읽으십시오.

Пред да се инсталира овој продукт, прочитајте информацијата за безбедност.

Les sikkerhetsinformasjonen (Safety Information) før du installerer dette produktet.

Przed zainstalowaniem tego produktu, należy zapoznać się z książką "Informacje dotyczące bezpieczeństwa" (Safety Information).

Antes de instalar este produto, leia as Informações sobre Segurança.

Перед установкой продукта прочтите инструкции по технике безопасности.

Pred inštaláciou tohto zariadenia si pečítajte Bezpečnostné predpisy.

Pred namestitvijo tega proizvoda preberite Varnostne informacije.

Antes de instalar este producto, lea la información de seguridad.

Läs säkerhetsinformationen innan du installerar den här produkten.

Important:

Each caution and danger statement in this document is labeled with a number. This number is used to cross reference an English-language caution or danger statement with translated versions of the caution or danger statement in the *IBM Safety Information* book.

For example, if a caution statement is labeled "Statement 1", translations for that caution statement are in the *Safety Information* document under "Statement 1".

Be sure to read all caution and danger statements in this document before you perform the procedures. Read any additional safety information that comes with the server or optional device before you install the device.

Statement 1:



DANGER

Electrical current from power, telephone, and communication cables is hazardous.

To avoid a shock hazard:

- **Do not connect or disconnect any cables or perform installation, maintenance, or reconfiguration of this product during an electrical storm.**
- **Connect all power cords to a properly wired and grounded electrical outlet.**
- **Connect to properly wired outlets any equipment that will be attached to this product.**
- **When possible, use one hand only to connect or disconnect signal cables.**
- **Never turn on any equipment when there is evidence of fire, water, or structural damage.**
- **Disconnect the attached power cords, telecommunications systems, networks, and modems before you open the device covers, unless instructed otherwise in the installation and configuration procedures.**
- **Connect and disconnect cables as described in the following table when installing, moving, or opening covers on this product or attached devices.**

To Connect:

1. Turn everything OFF.
2. First, attach all cables to devices.
3. Attach signal cables to connectors.
4. Attach power cords to outlet.
5. Turn device ON.

To Disconnect:

1. Turn everything OFF.
2. First, remove power cords from outlet.
3. Remove signal cables from connectors.
4. Remove all cables from devices.

Statement 2:



CAUTION:

When replacing the lithium battery, use only IBM Part Number 33F8354 or an equivalent type battery recommended by the manufacturer. If your system has a module containing a lithium battery, replace it only with the same module type made by the same manufacturer. The battery contains lithium and can explode if not properly used, handled, or disposed of.

Do not:

- **Throw or immerse into water**
- **Heat to more than 100°C (212°F)**
- **Repair or disassemble**

Dispose of the battery as required by local ordinances or regulations.

Statement 3:



CAUTION:

When laser products (such as CD-ROMs, DVD drives, fiber optic devices, or transmitters) are installed, note the following:

- Do not remove the covers. Removing the covers of the laser product could result in exposure to hazardous laser radiation. There are no serviceable parts inside the device.
- Use of controls or adjustments or performance of procedures other than those specified herein might result in hazardous radiation exposure.



DANGER

Some laser products contain an embedded Class 3A or Class 3B laser diode. Note the following.

Laser radiation when open. Do not stare into the beam, do not view directly with optical instruments, and avoid direct exposure to the beam.



Class 1 Laser Product
Laser Klasse 1
Laser Klass 1
Luokan 1 Laserlaite
Appareil À Laser de Classe 1

Statement 4:

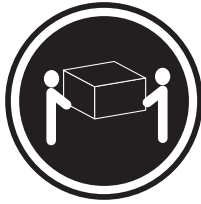

≥ 18 kg (39.7 lb)



≥ 32 kg (70.5 lb)

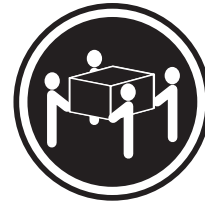

≥ 55 kg (121.2 lb)

CAUTION:

Use safe practices when lifting.

Statement 5:



CAUTION:

The power control button on the device and the power switch on the power supply do not turn off the electrical current supplied to the device. The device also might have more than one power cord. To remove all electrical current from the device, ensure that all power cords are disconnected from the power source.



Statement 8:



CAUTION:

Never remove the cover on a power supply or any part that has the following label attached.



Hazardous voltage, current, and energy levels are present inside any component that has this label attached. There are no serviceable parts inside these components. If you suspect a problem with one of these parts, contact a service technician.

Statement 11:



CAUTION:

The following label indicates sharp edges, corners, or joints nearby.



Statement 17:



CAUTION:

The following label indicates moving parts nearby.



Attention: This product is suitable for use on an IT power distribution system whose maximum phase to phase voltage is 240 V under any distribution fault condition.

Chapter 1. The System x3500 server

The IBM® System x3500 Type 7977 server is a 5-U¹-high high performance server. It can be upgraded to a symmetric multiprocessing (SMP) server through a microprocessor upgrade. It is ideally suited for networking environments that require superior microprocessor performance, efficient memory management, flexibility, and large amounts of reliable data storage.

Performance, ease of use, reliability, and expansion capabilities were key considerations in the design of the server. These design features make it possible for you to customize the system hardware to meet your needs today and provide flexible expansion capabilities for the future.

The server comes with a limited warranty. For information about the terms of the warranty and getting service and assistance, see the *Warranty and Support Information* document.

The server contains IBM Enterprise X-Architecture technologies, which help increase performance and reliability. For more information, see “What your server offers” on page 4 and “Reliability, availability, and serviceability” on page 5.

You can obtain up-to-date information about the server and other IBM server products at <http://www.ibm.com/eserver/xseries/>.

Related documentation

This *User's Guide* contains general information about the server, including how to install supported optional devices and how to configure the server. The following documentation also comes with the server:

- **Important Notices**

This 8 page printed document contains important safety and legal information pertaining to your server.

- **Installation Guide**

This document is in PDF on the *System x Documentation* CD. It contains instructions for setting up the server and basic instructions for installing some optional devices.

- **Warranty and Support Information**

This document is in Portable Document Format (PDF) on the IBM *System x Documentation* CD. It contains information about the terms of the warranty and getting service and assistance.

- **Safety Information**

This document is in PDF on the IBM *System x Documentation* CD. It contains translated caution and danger statements. Each caution and danger statement that appears in the documentation has a number that you can use to locate the corresponding statement in your language in the *Safety Information* document.

- **Problem Determination and Service Guide**

This document is in PDF on the IBM *System x Documentation* CD. It contains information to help you solve problems yourself, and it contains information for service technicians.

1. Racks are measured in vertical increments of 4.45 cm (1.75 inches) each. Each increment is called a “U.” A 1-U-high device is 1.75 inches tall.

Depending on the server model, additional documentation might be included on the *IBM System x Documentation CD*.

The System x and xSeries Tools Center is an online information center that contains information about tools for updating, managing, and deploying firmware, device drivers, and operating systems. The System x and xSeries Tools Center is at <http://publib.boulder.ibm.com/infocenter/toolsctr/v1r0/index.jsp>.

The server might have features that are not described in the documentation that comes with the server. The documentation might be updated occasionally to include information about those features, or technical updates might be available to provide additional information that is not included in the server documentation. These updates are available from the IBM Web site. To check for updated documentation and technical updates, complete the following steps.

Note: Changes are made periodically to the IBM Web site. The actual procedure might vary slightly from what is described in this document.

1. Go to <http://www.ibm.com/systems/support/>.
2. Under **Product support**, click **System x**.
3. Under **Popular links**, click **Publications lookup**.
4. From the **Product family** menu, select **System x3500** and click **Continue**.

Notices and statements in this document

The caution and danger statements that appear in this document are also in the multilingual *Safety Information* document, which is on the *IBM System x Documentation CD*. Each statement is numbered for reference to the corresponding statement in the *Safety Information* document.

The following notices and statements are used in this document:

- **Note:** These notices provide important tips, guidance, or advice.
- **Important:** These notices provide information or advice that might help you avoid inconvenient or problem situations.
- **Attention:** These notices indicate potential damage to programs, devices, or data. An attention notice is placed just before the instruction or situation in which damage might occur.
- **Caution:** These statements indicate situations that can be potentially hazardous to you. A caution statement is placed just before the description of a potentially hazardous procedure step or situation.
- **Danger:** These statements indicate situations that can be potentially lethal or extremely hazardous to you. A danger statement is placed just before the description of a potentially lethal or extremely hazardous procedure step or situation.

Features and specifications

The following information is a summary of the features and specifications of the server. Depending on the server model, some features might not be available, or some specifications might not apply.

Table 1. Features and specifications

<p>Microprocessor:</p> <ul style="list-style-type: none"> Intel® Xeon™ dual-core or quad-core with 12 MB Level-2 cache <p>Important: Do not use dual-core and quad-core processors in the same server.</p> <ul style="list-style-type: none"> Support for up to two microprocessors Support for Intel Extended Memory 64 Technology (EM64T) <p>Note: Use the Configuration/Setup Utility program to determine the type and speed of the microprocessors.</p> <p>Memory:</p> <ul style="list-style-type: none"> Minimum: 1 GB depending on server model, expandable to 48 GB Type: 667 MHz, PC2-5300, ECC Fully Buffered DIMMs (FBD) with double data rate (DDR) II, SDRAM Connectors: Twelve 240-pin dual inline memory module (DIMM) connectors <p>Drives:</p> <ul style="list-style-type: none"> IDE: <ul style="list-style-type: none"> DVD (standard) CD, CD-RW, DVD/CD-RW (optional) Maximum of two devices can be installed Diskette (optional): External USB 1.44 MB Supported hard disk drives: <ul style="list-style-type: none"> Serial Attached SCSI (SAS) Serial Advanced Technology Attachment (SATA) <p>Expansion bays:</p> <ul style="list-style-type: none"> Eight hot-swap SAS, 3.5-inch bays or 12 hot-swap SAS, 2.5-inch bays Three half-high 5.25-inch bays (DVD drive installed) <p>Note: Full-high devices such as an optional tape drive will occupy two half-high 5.25-inch bays.</p> <p>PCI and PCI-X expansion slots:</p> <ul style="list-style-type: none"> Six PCI expansion slots <ul style="list-style-type: none"> Three PCI Express x8 (two x8 links and one x4 link) One PCI 33 MHz/32-bit Two PCI-X 2.0 133 MHz/64-bit slots <p>Upgradeable microcode: System BIOS, service microprocessor, BMC, and SAS microcode</p> <p>Power supply:</p> <p>Note: To upgrade to two 835-watt hot-swap power supplies, install the redundant power and cooling option kit. Kit includes one 835-watt power-supply and three hot-swap fans.</p> <ul style="list-style-type: none"> Standard: One 835-watt 110 V or 240 V ac input dual-rated power supply Upgradeable to two 835-watt hot-swap power supplies 	<p>Hot-swap fans:</p> <ul style="list-style-type: none"> Three (standard) Upgradeable to six fans (for redundant cooling) <p>Note: To upgrade to redundant cooling, install the redundant power and cooling option kit. Kit includes one 835-watt hot-swap power-supply and three hot-swap fans.</p> <p>Size:</p> <ul style="list-style-type: none"> Tower <ul style="list-style-type: none"> Height: 440 mm (17.3 in.) Depth: 747 mm (29.4 in.) Width: 218 mm (8.6 in.) Weight: approximately 38 kg (84 lb) when fully configured or 20 kg (42 lb) minimum Rack <ul style="list-style-type: none"> 5 U Height: 218 mm (8.6 in.) Depth: 696 mm (27.4 in.) Width: 424 mm (16.7 in.) Weight: approximately 34 kg (75 lb) when fully configured or 20 kg (42 lb) minimum <p>Racks are marked in vertical increments of 4.45 cm (1.75 inches). Each increment is referred to as a unit, or "U." A 1-U-high device is 4.45 cm (1.75 inches) tall.</p> <p>Integrated functions:</p> <ul style="list-style-type: none"> Baseboard management controller (Intelligent Platform Management Interface (IPMI) 2.0 compliant) Service microprocessor support for Remote Supervisor Adapter II SlimLine Light path diagnostics ServeRAID-8k (512 MB with battery backup) and ServeRAID-8s SAS Controllers support RAID levels 0, 1, 1E, 5, 6, 10, 50, and 60 <p>Note: The server will not start without a RAID controller installed.</p> <ul style="list-style-type: none"> Eight 3.5-inch hard disk drive models: ServeRAID-8k Twelve 2.5-inch hard disk drive models: ServeRAID-8k and ServeRAID-8s Four Universal Serial Bus (USB) ports (2.0) <ul style="list-style-type: none"> Two on rear of server Two on front of server Broadcom 5721 and 5721KFB3 10/100/1000 Gigabit Ethernet controllers ATI PCI ES1000 video <ul style="list-style-type: none"> 16 MB video memory VGA and SVGA compatible ATA-100 single-channel IDE controller (bus mastering) Vitesse VSC7250 SAS/SATA RAID controller Mouse connector Keyboard connector Serial connector 	<p>Acoustical noise emissions:</p> <ul style="list-style-type: none"> Sound power, idle: 5.5 bel declared Sound power, operating: 6.0 bel declared <p>Environment:</p> <ul style="list-style-type: none"> Air temperature: <ul style="list-style-type: none"> Server on: 10° to 35°C (50.0° to 95.0°F); altitude: 0 to 2134 m (7000 ft) Server off: -40° to 60°C (-40.0° to 140.4°F); maximum altitude: 2134 m (7000 ft) Humidity: <ul style="list-style-type: none"> Server on: 8% to 80% Server off: 8% to 80% <p>Heat output:</p> <p>Approximate heat output in British thermal units (Btu) per hour:</p> <ul style="list-style-type: none"> Minimum configuration: 2013 Btu per hour (590 watts) Maximum configuration: 2951 Btu per hour (865 watts) <p>Electrical input:</p> <ul style="list-style-type: none"> Sine-wave input (50-60 Hz) required Input voltage low range: <ul style="list-style-type: none"> Minimum: 100 V ac Maximum: 127 V ac Input voltage high range: <ul style="list-style-type: none"> Minimum: 200 V ac Maximum: 240 V ac Approximate input kilovolt-amperes (kVA): <ul style="list-style-type: none"> Minimum: 0.60 kVA Maximum: 0.88 kVA <p>Notes:</p> <ol style="list-style-type: none"> Power consumption and heat output vary depending on the number and type of optional features that are installed and the power-management optional features that are in use. These levels were measured in controlled acoustical environments according to the procedures that are specified by the American National Standards Institute (ANSI) S12.10 and ISO 7779 and are reported in accordance with ISO 9296. Actual sound-pressure levels in a given location might exceed the average stated values because of room reflections and other nearby noise sources. The declared sound-power levels indicate an upper limit, below which a large number of computers will operate.
----------------------------------------------------------------------------------------------------------------------------------------------------------------------------------------------------------------------------------------------------------------------------------------------------------------------------------------------------------------------------------------------------------------------------------------------------------------------------------------------------------------------------------------------------------------------------------------------------------------------------------------------------------------------------------------------------------------------------------------------------------------------------------------------------------------------------------------------------------------------------------------------------------------------------------------------------------------------------------------------------------------------------------------------------------------------------------------------------------------------------------------------------------------------------------------------------------------------------------------------------------------------------------------------------------------------------------------------------------------------------------------------------------------------------------------------------------------------------------------------------------------------------------------------------------------------------------------------------------------------------------------------------------------------------------------------------------------------------------------------------------------------------------------------------------------------------------------------------------------------------------------------------------------------------------------------------------------------------------------------------------------------------------------------------------------------------------------------------------------------------------------------------------------------------------------------------------------------------------------------------------------------------------------------------------------------------------------------------------------------------------------------------------------------------------------------------------------------------------------	------------------------------------------------------------------------------------------------------------------------------------------------------------------------------------------------------------------------------------------------------------------------------------------------------------------------------------------------------------------------------------------------------------------------------------------------------------------------------------------------------------------------------------------------------------------------------------------------------------------------------------------------------------------------------------------------------------------------------------------------------------------------------------------------------------------------------------------------------------------------------------------------------------------------------------------------------------------------------------------------------------------------------------------------------------------------------------------------------------------------------------------------------------------------------------------------------------------------------------------------------------------------------------------------------------------------------------------------------------------------------------------------------------------------------------------------------------------------------------------------------------------------------------------------------------------------------------------------------------------------------------------------------------------------------------------------------------------------------------------------------------------------------------------------------------------------------------------------------------------------------------------------------------------------------------------------------------------------------------------------------------------------------------------------------------------------------------------------------------------------------------------------------------------------------------------------------------------------------------------------------------------------------------------------------------------------------------------------------------------------------------------------------------------------------	-----------------------------------------------------------------------------------------------------------------------------------------------------------------------------------------------------------------------------------------------------------------------------------------------------------------------------------------------------------------------------------------------------------------------------------------------------------------------------------------------------------------------------------------------------------------------------------------------------------------------------------------------------------------------------------------------------------------------------------------------------------------------------------------------------------------------------------------------------------------------------------------------------------------------------------------------------------------------------------------------------------------------------------------------------------------------------------------------------------------------------------------------------------------------------------------------------------------------------------------------------------------------------------------------------------------------------------------------------------------------------------------------------------------------------------------------------------------------------------------------------------------------------------------------------------------------------------------------------------------------------------------------------------------------------------------------------------------------------------------------------------------------------------------------------------------------------------------------------------------------------------------------------------------------------------------------------------------------------------------------------------------------------------------------------------------------------------------------------------------------------------------------------------------------------------------------------------------------------

What your server offers

The server uses the following features and technologies:

- **Baseboard management controller**

The baseboard management controller provides basic service-processor environmental monitoring functions. If an environmental condition exceeds a threshold or if a system component fails, the baseboard management controller lights LEDs to help you diagnose the problem.

- **Device Driver and IBM Enhanced Diagnostics CD**

The server comes with a *Device Driver and IBM Enhanced Diagnostics CD*, which you can use to diagnose problems.

- **IBM Director**

IBM Director is a workgroup-hardware-management tool that you can use to centrally manage xSeries® servers. For more information, see the IBM Director documentation on the *IBM Director CD*.

- **IBM ServerGuide™ Setup and Installation CD**

The *ServerGuide Setup and Installation CD* that comes with the server provides programs to help you set up the server and install a Windows operating system. The ServerGuide program detects installed optional hardware devices and provides the correct configuration programs and device drivers. For more information about the *ServerGuide Setup and Installation CD*, see “Using the ServerGuide Setup and Installation CD” on page 59.

- **Integrated network support**

The server comes with two integrated Broadcom 5721 series Gigabit Ethernet controllers, which supports connection to a 10 Mbps, 100 Mbps, or 1000 Mbps network. For more information, see “Configuring the Broadcom Gigabit Ethernet controller” on page 74.

- **Intelligent Platform Management Interface (IPMI) 2.0**

IPMI 2.0 support providing secure remote power-on/power-off and several standard alerts for components such as fans, voltage, and temperature.

- **Large data-storage capacity and hot-swap capability**

The server supports up to eight 25.4 mm (1-inch) slim-high, 3.5-inch hot-swap hard disk drives in the hot-swap bays. With the hot-swap feature, you can add, remove, or replace hard disk drives without turning off the server.

- **Large system-memory capacity**

The server supports up to 48 GB of system memory. The memory controller supports error correcting code (ECC) for up to 12 single-sided industry-standard PC-5300, 677 megahertz (MHz), 1.8 V, 240-pin, fully buffered, double-data-rate (DDR) II, synchronous dynamic random access memory (SDRAM) dual inline memory modules (DIMMs).

- **Light path diagnostics**

Light path diagnostics provides LEDs to help you diagnose problems. For more information, see the section about light path diagnostics in the *Problem Determination and Service Guide* on the *IBM System x Documentation CD*.

- **Memory mirroring**

Memory mirroring replicates and stores data in DIMMs within two branches simultaneously. To support memory mirroring, you must have at least two pairs of DIMMs installed (one pair in each branch). Pairs of DIMMs that are next to each other (for example, DIMM slot 1 and DIMM slot 4) within the channels of the same branch must be identical pairs of fully-buffered, dual inline memory modules (DIMMs).

- **Online-spare memory**
Online-spare memory disables a failed rank pair of DIMMs from the system configuration and activates an online-spare rank pair of DIMMs to replace the failed rank pair of DIMMs. For an online-spare pair of DIMMs to be activated, you must enable this feature and have installed an additional pair of DIMMs of the same speed, type, size (or larger), and technology as the failed pair of DIMMs.
- **PCI-X adapter capabilities**
The server has two slots for PCI-X 64-bit adapters.
- **PCI Express x4 adapter capabilities**
The server has one slot for PCI Express x4 adapters. These slots accept x8 adapters, but the adapters will operate as x4 adapters.
- **PCI Express x8 adapter capabilities**
The server has two slots for PCI Express x8 adapters.
- **Redundant cooling and power capabilities**
The server supports up to two 835-watt hot-swap power supplies. If the server comes with only one power supply, you can install an additional power supply with three redundant hot-swap cooling fans to add redundant power and cooling capabilities. If the maximum load on the server is less than 835 watts and a problem occurs with one of the power supplies, the other power supply can meet the power requirements. The redundant cooling of the fans enables continued operation if one of the fans fails.
- **ServeRAID™ support**
The server supports ServeRAID adapters to create redundant array of independent disks (RAID) configurations.
- **Symmetric multiprocessing (SMP)**
The server supports up to two Intel Xeon dual-core microprocessors. If the server comes with only one microprocessor, you can install an additional microprocessor to enhance performance and provide SMP capability.
- **Systems-management capabilities**
The server comes with a Remote Supervisor Adapter II SlimLine, which provides service-processor functions in addition to those that the baseboard management controller provides. When this adapter is used with the systems-management software that comes with the server, you can manage the functions of the server locally and remotely. The Remote Supervisor Adapter II SlimLine also provides system monitoring, event recording, and dial-out alert capability.

Reliability, availability, and serviceability

Three important server design features are reliability, availability, and serviceability (RAS). The RAS features help to ensure the integrity of the data that is stored in the server, the availability of the server when you need it, and the ease with which you can diagnose and correct problems.

The server has the following RAS features:

- 3-year parts, 3-year labor limited warranty
- Advanced Configuration and Power Interface (ACPI)
- Advanced Desktop Management Interface (DMI) features
- Automatic error retry or recovery
- Automatic memory downsizing on error detection
- Automatic restart on nonmaskable interrupt (NMI)

- Automatic Server Restart (ASR) logic supporting a system restart when the operating system becomes unresponsive
- Automatic server restart after a power failure, based on the BIOS setting
- Availability of microcode level
- Boot-block recovery
- Built-in, menu-driven setup, system configuration, and redundant array of independent disks (RAID) configuration
- Built-in monitoring for fan, power, temperature, and voltage
- CD-based diagnostic programs
- Cooling fans with speed-sensing capability
- Customer support center that is available 24 hours a day, 7 days a week²
- Diagnostic support of ServeRAID adapters
- Error codes and messages
- Error correcting code (ECC) double-data-rate (DDR) synchronous dynamic random access memory (SDRAM) with serial presence detect (SPD)
- Error logging of POST failures
- Hot-swap SAS hard disk drives
- Integrated Ethernet controllers
- Intelligent Platform Management Interface (IPMI) 2.0
- Support for the optional IBM Remote Supervisor Adapter II SlimLine
- Key-lock support for physical security
- Memory change messages posted to the error log
- Power-on self-test (POST)
- Predictive Failure Analysis[®] (PFA) alerts
- Read-only memory (ROM) checksums
- Redundant Ethernet capabilities (requires an optional Ethernet adapter) with failover support
- Standby voltage for system-management features and monitoring
- System auto-configuring from the configuration menu
- System-error LED on the front bezel and diagnostics LEDs on the system board
- Upgradeable microcode for POST, BIOS, and read-only memory (ROM) resident code, locally or over a LAN
- Vital product data (VPD); includes serial-number information and replacement part numbers, stored in nonvolatile memory, for easier remote maintenance
- Wake on LAN[®] capability

IBM Director

With IBM Director, a network administrator can perform the following tasks:

- View the hardware configuration of remote systems, in detail
- Monitor the usage and performance of critical components, such as microprocessors, disks, and memory
- Centrally manage individual or large groups of IBM and non-IBM Intel-processor-based servers, desktop computers, workstations, and notebook computers on a variety of platforms

². Service availability will vary by country. Response time varies; may exclude holidays.

IBM Director provides a comprehensive entry-level workgroup hardware manager. It includes the following key features:

- Advanced self-management capabilities for maximum system availability.
- Multiple operating-system platform support, including Microsoft® Windows® 2000 Server, Windows Server 2003, Windows XP Professional, AIX, i5/OS, Red Hat Linux, SUSE Linux, VMware, and Novell NetWare. For a complete list of operating systems that support IBM Director, see the IBM Director Compatibility Document. This document is in Portable Document Format (PDF) at <http://www.ibm.com/syems/management/director/resources/>. It is updated every 6 to 8 weeks.
- Support for IBM and non-IBM servers, desktop computers, workstations, and notebook computers.
- Support for systems-management industry standards.
- Integration into leading workgroup and enterprise systems-management environments.
- Ease of use, training, and setup.

IBM Director also provides an extensible platform that supports advanced server tools that are designed to reduce the total cost of managing and supporting networked systems. By deploying IBM Director, you can achieve reductions in ownership costs through the following benefits:

- Reduced downtime
- Increased productivity of IT personnel and users
- Reduced service and support costs

For more information about IBM Director, see the documentation on the *IBM Director* CD that comes with the server, the IBM Director Information Center at http://publib.boulder.ibm.com/infocenter/eserver/v1r2/topic/dirinfo_all/diicinfoparent.html, and the IBM System x Systems Management Web page at <http://www.ibm.com/systems/management/>, which presents an overview of IBM Systems Management and IBM Director.

The Update*Xpress* program

The Update*Xpress* program is available for most System x servers and server optional devices. It detects supported and installed device drivers and firmware in the server and installs available updates. You can download the Update*Xpress* program from the Web at no additional cost, or you can purchase it on a CD. To download the program or purchase the CD, go to <http://www.ibm.com/sytemes/management/xpress.html>.

Front view

The following illustration shows the controls and LEDs on the front of the server.

Note: The front bezel door is not shown so that the drive bays are visible.

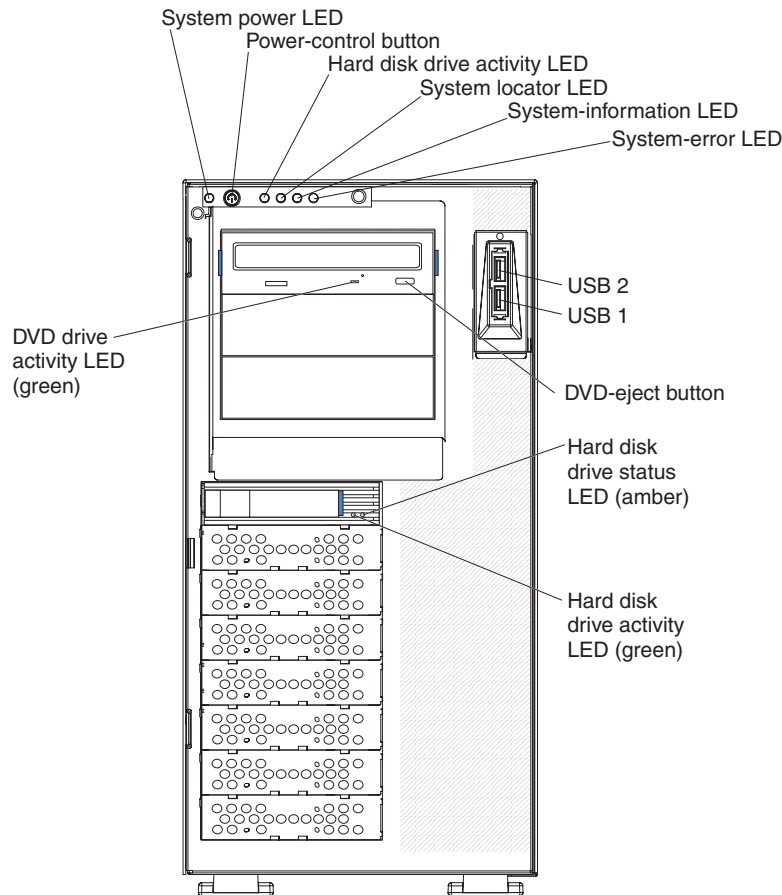

System Power-on LED: When this LED is lit and not flashing, it indicates that the server is turned on. When this LED is flashing, it indicates that the server is turned off and still connected to an ac power source. When this LED is off, it indicates that ac power is not present, or the power supply or the LED itself has failed. A power LED is also on the rear of the server.

Power-control button: Press this button to turn the server on and off manually. A power-control-button shield comes with the server. You can install this disk-shaped shield to prevent the server from being turned off accidentally.

Hard disk drive activity LED: When this LED is flashing, it indicates that a hard disk drive is in use.

System locator LED: Use this LED to visually locate the server among other servers. You can use IBM Director to light this LED remotely.

System-information LED: When this amber LED is on, the server power supplies are nonredundant, or some other noncritical event has occurred. The event is recorded in the error log. Check the light path diagnostic panel for more information (see the *Problem Determination and Service Guide* on the IBM System x Documentation CD).

System-error LED: When this amber LED is lit, it indicates that a system error has occurred. Use the diagnostic LED panel and the system service label on the inside of the left-side cover to further isolate the error. See the *Problem Determination and Service Guide* on the IBM *System x Documentation* CD for additional information.

USB 1 connector: Connect USB devices to these connectors.

USB 2 connector: Connect USB devices to these connectors.

DVD-eject button: Press this button to release a CD or DVD from the DVD drive.

Hard disk drive status LED: When this LED is lit, it indicates that the associated hard disk drive has failed. If an optional RAID adapter is installed in the server and the LED flashes slowly (one flash per second), the drive is being rebuilt. If the LED flashes rapidly (three flashes per second), the controller is identifying the drive.

Hard disk drive activity LED: When this LED is flashing, it indicates that the drive is in use.

Hard disk drive status LED: On some server models, each hot-swap hard disk drive has a status LED. When this LED is lit, it indicates that the drive has failed. If an optional IBM ServeRAID controller is installed in the server, when this LED is flashing slowly (one flash per second), it indicates that the drive is being rebuilt. When the LED is flashing rapidly (three flashes per second), it indicates that the controller is identifying the drive.

DVD drive activity LED: When this LED is lit, it indicates that the DVD drive is in use.

Rear view

The following illustration shows the connectors and LEDs on the rear of the server.

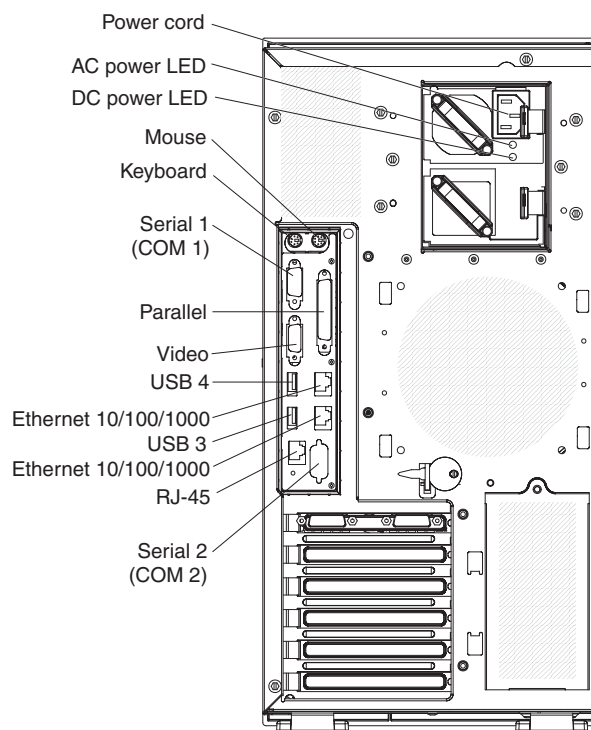

Power-cord connector: Connect the power cord to this connector.

Mouse connector: Connect a mouse or other PS/2 device to this connector.

Keyboard connector: Connect a PS/2 keyboard to this connector.

COM 1 connector: Connect a 9-pin serial device to this connector.

Parallel connector: Connect a parallel device to this connector.

Video connector: Connect a monitor to this connector.

USB 3 connector: Connect a USB device to this connector.

Ethernet connector: Use this connector to connect the server to a network.

USB 4 connector: Connect a USB device to this connector.

Ethernet connector: Use this connector to connect the server to a network.

RJ-45: Use this connector to connect the optional Remote Supervisor Adapter II SlimLine to a network.

Serial 2 (COM 2) connector: Connect a 9-pin serial device to this connector. This connector can also be redirected in the Configuration/Setup Utility program for use with the baseboard management controller (BMC) or Remote Supervisor Adapter II

SlimLine to control the server remotely. Do not connect any 9-pin serial devices to this connector when it is configured for use with the BMC or Remote Supervisor Adapter II SlimLine.

Note: When this connector is configured for use with the system management, do not connect any other 9-pin serial devices to this connector.

Server power features

When the server is connected to an ac power source but is not turned on, the operating system does not run, and all core logic except for the service processor is shut down; however, the server can respond to requests from the service processor, such as a remote request to turn on the server. The power-on LED flashes to indicate that the server is connected to ac power but not turned on.

Turning on the server

Approximately 20 seconds after the server is connected to ac power, the power-control button becomes active, and one or more fans might start running to provide cooling while the server is connected to power. You can turn on the server and start the operating system by pressing the power-control button.

The server can also be turned on in any of the following ways:

- If a power failure occurs while the server is turned on, the server will restart automatically when power is restored.
- If the server is connected to an Advanced System Management interconnect network that contains at least one server with an optional Remote Supervisor Adapter installed, the server can be turned on from the Remote Supervisor Adapter user interface.
- If your operating system supports the systems-management software for an optional Remote Supervisor Adapter, the systems-management software can turn on the server.
- If your operating system supports the Wake on LAN feature, the Wake on LAN feature can turn on the server.

Turning off the server

When you turn off the server and leave it connected to ac power, the server can respond to requests from the service processor, such as a remote request to turn on the server. While the server remains connected to ac power, one or more fans might continue to run. To remove all power from the server, you must disconnect it from the power source.

Some operating systems require an orderly shutdown before you turn off the server. See your operating-system documentation for information about shutting down the operating system.

Statement 5:



CAUTION:

The power control button on the device and the power switch on the power supply do not turn off the electrical current supplied to the device. The device also might have more than one power cord. To remove all electrical current from the device, ensure that all power cords are disconnected from the power source.

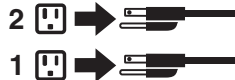

The server can be turned off in any of the following ways:

- You can turn off the server from the operating system, if your operating system supports this feature. After an orderly shutdown of the operating system, the server will be turned off automatically.
- You can press the power-control button to start an orderly shutdown of the operating system and turn off the server, if your operating system supports this feature.
- If the operating system stops functioning, you can press and hold the power-control button for more than 4 seconds to turn off the server.
- If the server is connected to an Advanced System Management interconnect network that contains at least one server with an optional Remote Supervisor Adapter installed, the server can be turned off from the Remote Supervisor Adapter user interface.
- If an optional Remote Supervisor Adapter is installed in the server, the server can be turned off from the Remote Supervisor Adapter user interface.
- The integrated system management processor can turn off the server as an automatic response to a critical system failure.
- You can turn off the server through a request from the service processor.

Chapter 2. Installing optional devices

This chapter provides detailed instructions for installing optional hardware devices in the server.

Server components

The following illustration shows the major components in the server.

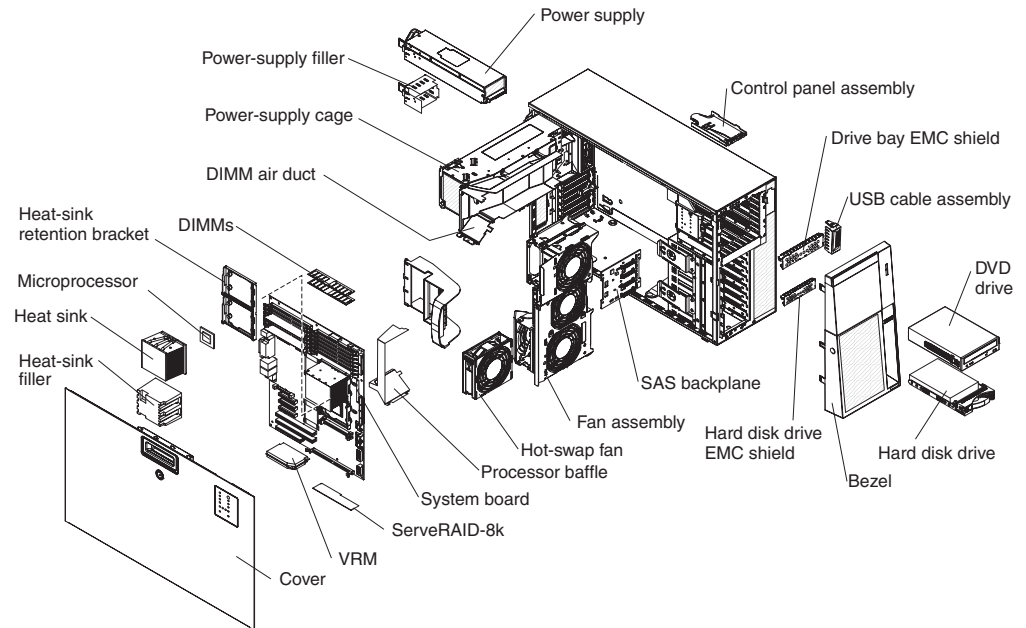

System-board internal connectors and switches

The following illustrations show the internal connectors and switches on the system board.

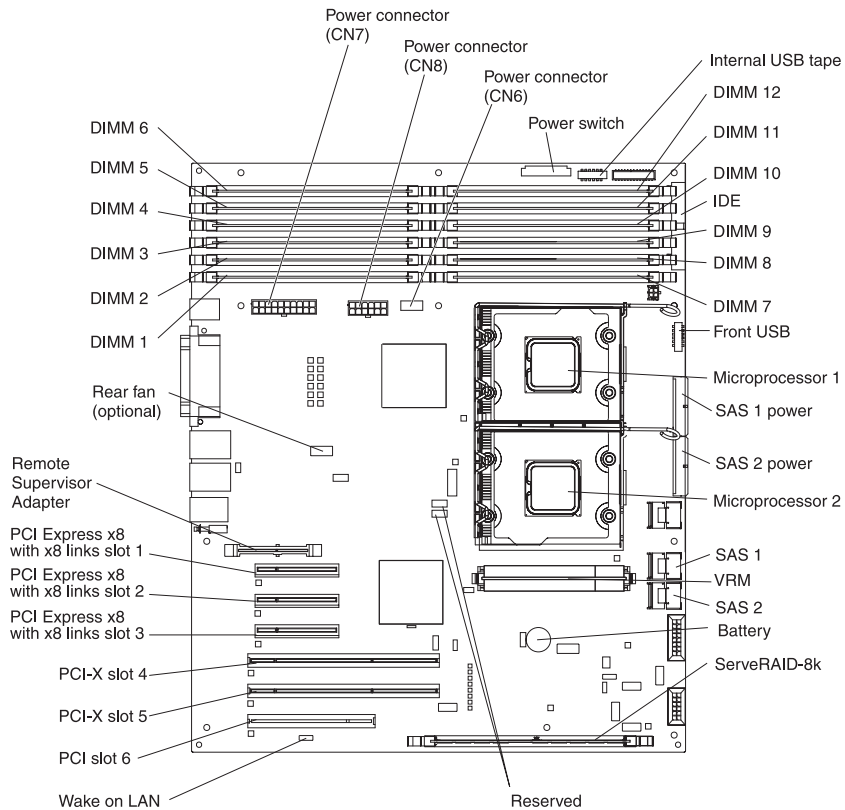

See Table 2 for information about the switch settings.

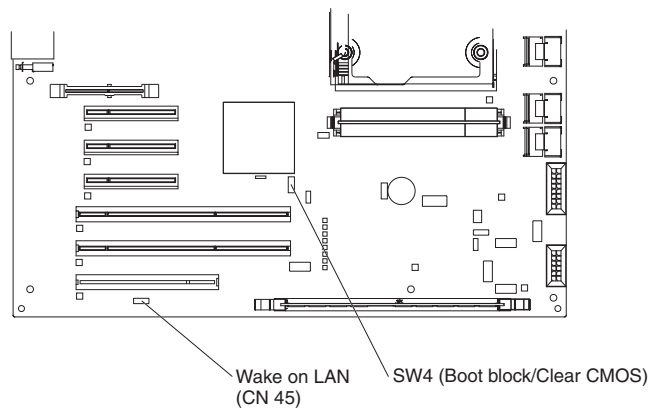

Table 2. Switches on SW4

Switch number	Description
1	Boot block: <ul style="list-style-type: none"> • Leave the switch in the off position for normal mode. • Move the switch to the on position to enable the system to recover if the BIOS code becomes damaged.

Table 2. Switches on SW4 (continued)

Switch number	Description
2	<p>Clear CMOS:</p> <ul style="list-style-type: none"> • Leave the switch in the off position to keep the CMOS data. • Move the switch to the on position to clear the CMOS data, which clears the power-on password and administrator password.

Notes:

1. Before you change any switch settings or move any jumpers, turn off the server; then, disconnect all power cords and external cables. (Review the information in “Safety” on page v, “Installation guidelines” on page 21, and “Handling static-sensitive devices” on page 22.)
2. Any system-board switch or jumper blocks that are not shown in the illustrations in this document are reserved.

System-board LEDs

The following illustration shows the LEDs on the system board.

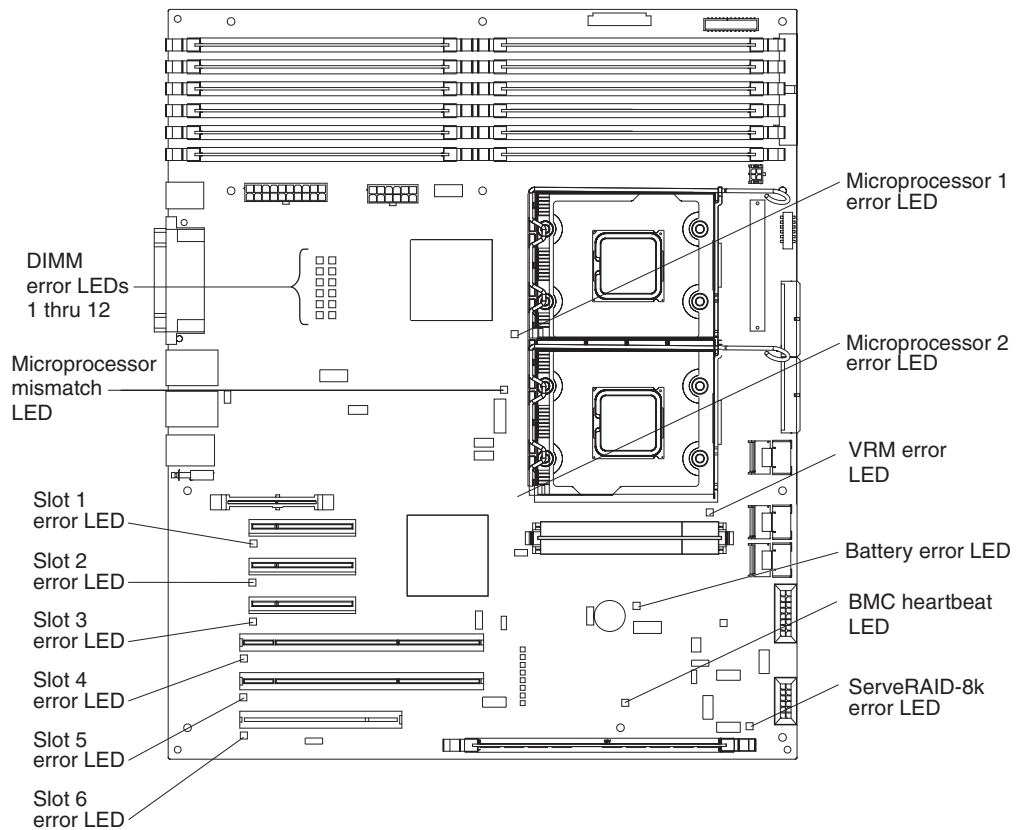

System-board external connectors

The following illustration shows the external input/output connectors and the NMI switch on the system board.

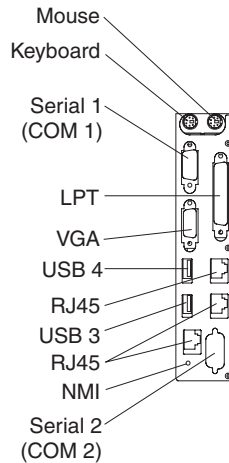

Light path diagnostics panel

The following illustration shows the remind button and the LEDs on the light path diagnostics panel. The light path diagnostics panel is inside the server under the left-side cover and the error LEDs are also visible through the left-side cover.

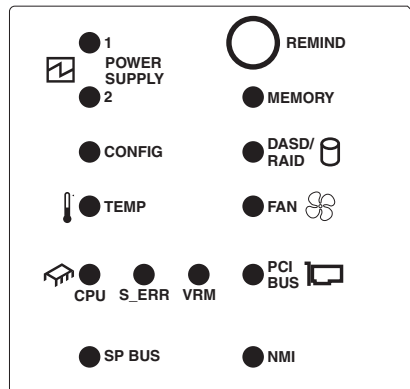

Use the remind button on the light path diagnostic panel to acknowledge that an error has occurred without taking further action. When you push the remind button, the system error LED will flash every 2 seconds until the error is fixed. If another error occurs, the system error LED will then stop flashing and return to a solid on state.

For more information about light path diagnostics, see the *Problem Determination and Service Guide* on the IBM System x Documentation CD.

The following table lists the light path diagnostics LEDs, the problems that they indicate, and actions to solve the problems.

- Follow the suggested actions in the order in which they are listed in the Action column until the problem is solved.
- See the *Problem Determination and Service Guide on the IBM System x Documentation CD* to determine which components are customer replaceable units (CRU) and which components are field replaceable units (FRU).
- If an action step is preceded by “(Trained service technician only),” that step must be performed only by a trained service technician.

Lit light path diagnostics LED with the system-error or information LED also lit	Description	Action
All LEDs are off (the power LED is lit; the information LED might be lit).		No action is necessary.
POWER SUPPLY 1	Power supply 1 has failed or has been removed. Note: In a redundant power configuration, the dc power LED on one power supply might be off.	<ol style="list-style-type: none"> 1. Reinstall the power supply 1. 2. Check the individual power-supply LEDs. 3. Reseat the following components: <ol style="list-style-type: none"> a. Power supply b. (Trained service technician only) Power backplane 4. Replace the components listed in step 3, one at a time, in the order shown, restarting the server each time. 5. If a 240 V ac fault has occurred, remove ac power before restoring dc power.
POWER SUPPLY 2	Power supply 2 has failed or has been removed. Note: In a redundant power configuration, the dc power LED on one power supply might be off.	<ol style="list-style-type: none"> 1. Reinstall the power supply 2. 2. Check the individual power-supply LEDs. 3. Reseat the following components: <ol style="list-style-type: none"> a. Power supply b. (Trained service technician only) Power backplane 4. Replace the components listed in step 3, one at a time, in the order shown, restarting the server each time. 5. If a 240 V ac fault has occurred, remove ac power before restoring dc power.
CONFIG	Microprocessor configuration error.	<ol style="list-style-type: none"> 1. Mismatched microprocessors, remove and install two microprocessor of the same cache size, type, and clock speed. 2. Check the system error log for information indicating incompatible components.

- Follow the suggested actions in the order in which they are listed in the Action column until the problem is solved.
- See the *Problem Determination and Service Guide on the IBM System x Documentation CD* to determine which components are customer replaceable units (CRU) and which components are field replaceable units (FRU).
- If an action step is preceded by “(Trained service technician only),” that step must be performed only by a trained service technician.

Lit light path diagnostics LED with the system-error or information LED also lit	Description	Action
TEMP	<p>A system temperature or component has exceeded specifications. Note: A fan LED might also be lit.</p>	<ol style="list-style-type: none"> 1. See the BMC log or the system-error log (see the <i>Problem Determination and Service Guide on the IBM System x Documentation CD</i>) for the source of the fault. 2. Make sure that the airflow in the server is not blocked. 3. If a fan LED is lit, reseal the fan. 4. Replace the fan for which the LED is lit. 5. Make sure that the room is neither too hot nor too cold (see “Environment” in “Features and specifications” on page 3).
CPU	<p>A microprocessor has failed, is missing, or has been incorrectly installed. Note: (Trained service technician only) Make sure that the microprocessors are installed in the correct sequence.</p>	<ol style="list-style-type: none"> 1. Check the BMC log or the system-error log to determine the reason for the lit LED. 2. Find the failing, missing, or mismatched microprocessor by checking the LEDs on the system board. 3. (Trained service technician only) Reseat the failing microprocessor 4. Replace the following components one at a time, in the order shown, restarting the server each time: <ol style="list-style-type: none"> a. (Trained service technician only) Failing microprocessor b. (Trained service technician only) System board
S_ERR	Reserved	
VRM	<p>A dc-dc regulator has failed or is missing. Note: This error is for either the VRM or integrated VRD. If the VRD has failed, the system board must be replaced by an trained service technician.</p>	<ol style="list-style-type: none"> 1. Check the BMC log or the system-error log to determine the reason for the lit LED (for a VRM). 2. Find the failing or missing VRM by checking the LEDs on the system board. 3. Install any missing VRMs. 4. Reseat the following components: <ol style="list-style-type: none"> a. Failing VRM b. (Trained service technician only) Microprocessor associated with the VRM 5. Replace the following components one at a time, in the order shown, restarting the server each time: <ol style="list-style-type: none"> a. Failing VRM b. (Trained service technician only) Microprocessor associated with the VRM c. (Trained service technician only) System board

<ul style="list-style-type: none"> • Follow the suggested actions in the order in which they are listed in the Action column until the problem is solved. • See the <i>Problem Determination and Service Guide on the IBM System x Documentation CD</i> to determine which components are customer replaceable units (CRU) and which components are field replaceable units (FRU). • If an action step is preceded by “(Trained service technician only),” that step must be performed only by a trained service technician. 		
Lit light path diagnostics LED with the system-error or information LED also lit	Description	Action
SERVICE PROCESSOR BUS	There is a fault in the Remote Supervisor Adapter II SlimLine.	<ol style="list-style-type: none"> 1. Reseat the Remote Supervisor Adapter II SlimLine. 2. Update the firmware for the Remote Supervisor Adapter II SlimLine (see the <i>Problem Determination and Service Guide on the IBM System x Documentation CD</i>). 3. Replace the Remote Supervisor Adapter II SlimLine.
MEMORY	Memory failure. Note: The error LED on the DIMM is also lit.	<ol style="list-style-type: none"> 1. Remove the DIMM that has the lit error LED; then, press the light path diagnostics button on the DIMM to identify the failed DIMM. 2. Reseat the DIMM. 3. Replace the following components one at a time, in the order shown, restarting the server each time: <ol style="list-style-type: none"> a. DIMM b. (Trained service technician only) System board
DASD/RAID	A hard disk drive, integrated SAS controller, or integrated RAID error has occurred. Notes: <ol style="list-style-type: none"> 1. The error LED on the failing hard disk drive is also lit. 2. Check the BMC event log for a ServeRAID-8k or RAID error. 	<ol style="list-style-type: none"> 1. Reinstall the removed drive. 2. Reseat the following components: <ol style="list-style-type: none"> a. Failing hard disk drive b. SAS hard disk drive backplane c. SAS signal and power cables d. System board e. ServeRAID-8k 3. Replace the components listed in step 2, one at a time, in the order shown, restarting the server each time.
FAN	A fan has failed or has been removed. Note: A failing fan can also cause the TEMP LED to be lit.	<ol style="list-style-type: none"> 1. Reinstall the removed fan. 2. If an individual fan LED is lit, replace the fan. 3. (Trained service technician only) Replace the system board.
PCI BUS	A PCI adapter has failed.	<ol style="list-style-type: none"> 1. See the BMC log or the system-error log (see the <i>Problem Determination and Service Guide on the IBM System x Documentation CD</i>). 2. Reseat the failing adapter. 3. Replace the following components, one at a time, in the order shown, restarting the server each time: <ol style="list-style-type: none"> a. Failing adapter b. (Trained service technician only) System board

- Follow the suggested actions in the order in which they are listed in the Action column until the problem is solved.
- See the *Problem Determination and Service Guide on the IBM System x Documentation CD* to determine which components are customer replaceable units (CRU) and which components are field replaceable units (FRU).
- If an action step is preceded by “(Trained service technician only),” that step must be performed only by a trained service technician.

Lit light path diagnostics LED with the system-error or information LED also lit	Description	Action
NMI	<p>A hardware error has been reported to the operating system.</p> <p>Note: The PCI or MEM LED might also be lit.</p>	<ol style="list-style-type: none"> 1. See the BMC log and the system-error log (see the <i>Problem Determination and Service Guide on the IBM System x Documentation CD</i>). 2. If the PCI LED is lit, follow the instructions for that LED. 3. If the MEM LED is lit, follow the instructions for that LED. 4. Restart the server.

Installation guidelines

Before you install optional devices, read the following information:

- Read the safety information that begins on page vii and the guidelines in “Handling static-sensitive devices” on page 22. This information will help you work safely.
- When you install your new server, take the opportunity to download and apply the most recent firmware updates. This step will help to ensure that any known issues are addressed and that your server is ready to function at maximum levels of performance. To download firmware updates for your server, go to <http://www.ibm.com/support/> and click **Downloads and drivers**.
- Before you install optional hardware, make sure that the server is working correctly. Start the server, and make sure that the operating system starts, if an operating system is installed, or that a 19990305 error code is displayed, indicating that an operating system was not found but the server is otherwise working correctly. If the server is not working correctly, see the *Problem Determination and Service Guide* on the IBM System x Documentation CD for information on how to run diagnostics.
- Observe good housekeeping in the area where you are working. Place removed covers and other parts in a safe place.
- If you must start the server while the cover is removed, make sure that no one is near the server and that no tools or other objects have been left inside the server.
- Do not attempt to lift an object that you think is too heavy for you. If you have to lift a heavy object, observe the following precautions:
 - Make sure that you can stand safely without slipping.
 - Distribute the weight of the object equally between your feet.
 - Use a slow lifting force. Never move suddenly or twist when you lift a heavy object.
 - To avoid straining the muscles in your back, lift by standing or by pushing up with your leg muscles.
- Make sure that you have an adequate number of properly grounded electrical outlets for the server, monitor, and other devices.
- Back up all important data before you make changes to disk drives.
- Have a small flat-blade screwdriver available.
- You do not have to turn off the server to install or replace hot-swap power supplies, hot-swap hard disk drives, hot-swap fans, or hot-plug Universal Serial Bus (USB) devices.
- Blue on a component indicates touch points, where you can grip the component to remove it from or install it in the server, open or close a latch, and so on.
- Orange on a component or an orange label on or near a component indicates that the component can be hot-swapped, which means that if the server and operating system support hot-swap capability, you can remove or install the component while the server is running. (Orange can also indicate touch points on hot-swap components.) See the instructions for removing or installing a specific hot-swap component for any additional procedures that you might have to perform before you remove or install the component.
- When you have to access the inside of the server, you might find it easier to lay the server on its side.
- You can install a maximum of two IDE devices in the server.

- For a list of supported optional devices for the server, see <http://www.ibm.com/servers/eserver/serverproven/compat/us/>.

System reliability guidelines

To help ensure proper cooling and system reliability, make sure that the following requirements are met:

- Each of the drive bays has a drive or an electromagnetic compatibility (EMC) shield installed in it.
- If the server has redundant power, each of the power-supply bays has a power-supply installed in it.
- There is adequate space around the server to allow the server cooling system to work properly. Leave approximately 50 mm (2.0 in.) of open space around the front and rear of the server. Do not place objects in front of the fans. For proper cooling and airflow, replace the left-side cover before you turn on the server. Operating the server for extended periods of time (more than 30 minutes) with the left-side cover removed might damage server components.
- You have followed the cabling instructions that come with optional adapters.
- You have replaced a failed fan within 48 hours.
- You have replaced a hot-swap drive within 2 minutes of removal.
- You do not remove the air duct or air baffles while the server is running. Operating the server without the air duct or air baffles might cause the microprocessor to overheat.
- Microprocessor socket 2 always contains either a microprocessor duct or a microprocessor and heat sink.

Working inside the server with the power on

The server supports hot-swap devices and is designed to operate safely while it is turned on and the cover is removed. Follow these guidelines when you work inside a server that is turned on:

- Avoid wearing loose-fitting clothing on your forearms. Button long-sleeved shirts before working inside the server; do not wear cuff links while you are working inside the server.
- Do not allow your necktie or scarf to hang inside the server.
- Remove jewelry, such as bracelets, necklaces, rings, and loose-fitting wrist watches.
- Remove items from your shirt pocket, such as pens and pencils, that might fall into the server as you lean over it.
- Avoid dropping any metallic objects, such as paper clips, hairpins, and screws, into the server.

Handling static-sensitive devices

Attention: Static electricity can damage the server and other electronic devices. To avoid damage, keep static-sensitive devices in their static-protective packages until you are ready to install them.

To reduce the possibility of damage from electrostatic discharge, observe the following precautions:

- Limit your movement. Movement can cause static electricity to build up around you.
- Wear an electrostatic-discharge wrist strap, if one is available.

- Handle the device carefully, holding it by its edges or its frame.
- Do not touch solder joints, pins, or exposed circuitry.
- Do not leave the device where others can handle and damage it.
- While the device is still in its static-protective package, touch it to an unpainted metal part of the server for at least 2 seconds. This drains static electricity from the package and from your body.
- Remove the device from its package and install it directly into the server without setting down the device. If it is necessary to set down the device, put it back into its static-protective package. Do not place the device on the server cover or on a metal surface.
- Take additional care when handling devices during cold weather. Heating reduces indoor humidity and increases static electricity.

Removing the bezel

Important: Before you install optional hardware, make sure that the server is working correctly. Start the server, and make sure that the operating system starts, if an operating system is installed, or that a 19990305 error code is displayed, indicating that an operating system was not found but the server is otherwise working correctly. If the server is not working correctly, see the *Problem Determination and Service Guide* for diagnostic information.

The following illustration shows how to remove the bezel from the server.

Notes:

1. The left-side cover does not have to be removed to remove the bezel from the server.
2. The left-side cover lock must be unlocked to open or remove the bezel.

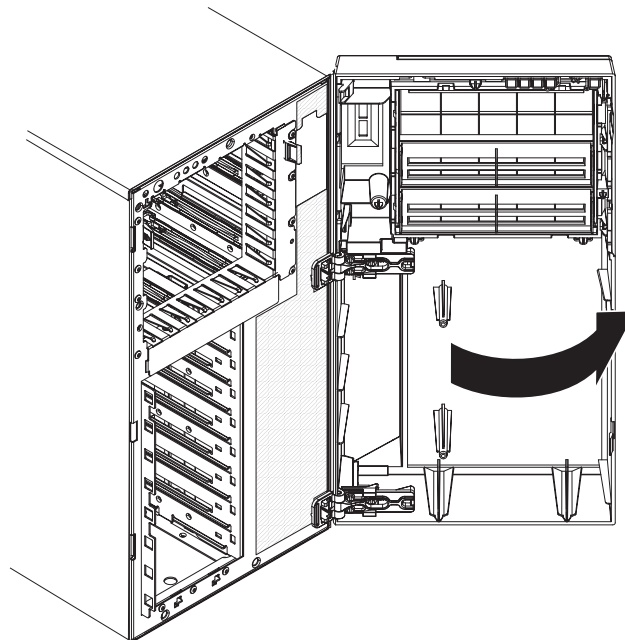

Complete the following steps to remove the bezel:

1. Read the safety information that begins on page v and “Installation guidelines” on page 21.
2. Using the supplied key, unlock the left-side cover and bezel.

3. Press on the left edge of the bezel, and rotate the left side of the bezel away from the server. Rotate the left edge of the bezel out beyond 90°; then, pull the bezel away from the server.

Removing the left-side cover

Important: Before you install optional hardware, make sure that the server is working correctly. Start the server, and make sure that the operating system starts, if an operating system is installed, or that a 19990305 error code is displayed, indicating that an operating system was not found but the server is otherwise working correctly. If the server is not working correctly, see the *Problem Determination and Service Guide* for diagnostic information.

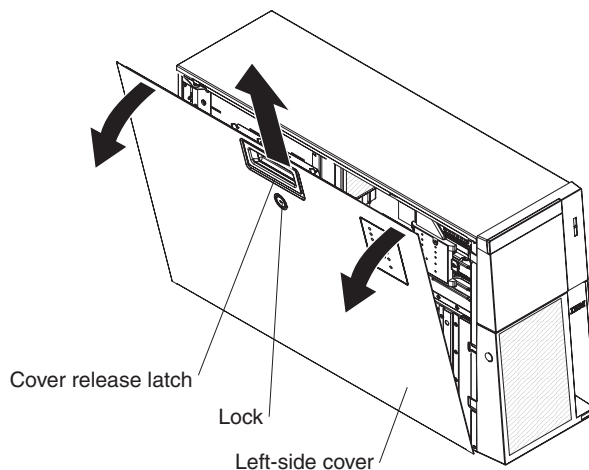

To remove the cover, complete the following steps:

1. Read the safety information that begins on page v and “Installation guidelines” on page 21.
2. Turn off the server and all attached devices.
3. Disconnect all external cables and power cords.
4. Using the supplied key, unlock the left-side cover.
5. Pull the cover-release latch down and rotate the top edge of the cover away from the server.

Attention: For proper cooling and airflow, replace the cover before you turn on the server. Operating the server for extended periods of time (more than 30 minutes) with the cover removed might damage server components.

6. Remove the left-side cover from the server.

Installing an adapter

The following notes describe the types of adapters that the server supports and other information that you must consider when you install an adapter:

- Locate the documentation that comes with the adapter and follow those instructions in addition to the instructions in this section. If you must change the switch or jumper settings on the adapter, follow the instructions that come with the adapter.
- Avoid touching the components and gold-edge connectors on the adapter.
- PCI slot 6 supports half-length 5.0 V PCI adapters only.
- PCI slot 1 supports half-length 3.3 V PCI adapters only.

- PCI slots 2 through 5 support full-length 3.3 V signaling adapters only.
- The PCI configuration:
 - Slot 1 is a PCI Express x8 slot with x4 links, PCI Express 1.0a compliant.
 - Slot 2 and 3 are PCI Express x8 slots with x8 links, PCI Express 1.0a compliant.
 - Slots 4 and 5 are PCI-X 133/64 slots, PCI-X 2.0 compliant.
 - Slot 6 is a PCI 33/32 slot, PCI 2.2 compliant.

Note: The ServeRAID-8k, ServeRAID-8s, and the optional ServeRAID-10is SAS Controllers override the standard functionality of the integrated SAS/SATA controller with RAID capabilities.

- The system scans PCI slots 1 through 6 to assign system resources. The system then starts (boots) the system devices in the following order, if you have not changed the default boot precedence: integrated Ethernet controller, ServeRAID-8k SAS Controller, and then PCI, PCI-X, and PCI Express slots.

Note: To change the boot precedence for PCI and PCI-X devices, start the Configuration/Setup Utility program and select **Start Options** from the main menu. See the “Using the Configuration/Setup Utility program” on page 54 for details about using the Configuration/Setup Utility program.

- The server uses a rotational interrupt technique to configure PCI adapters so that you can install PCI adapters that do not support sharing of PCI interrupts.
- You can order an optional IBM ServeRAID-MR10is VAULT SAS/SATA Controller that supports RAID levels 0, 1, 5, 6, 10, 50, and 60. You can install the ServeRAID-MR10is SAS/SATA controller only in server models with eight 3.5 inch hot-swap hard disk drives installed.

Note: Note: The onboard RAID controller will be disabled by BIOS when the ServeRAID-MR10is SAS/SATA controller is installed in the server.

Attention: Static electricity that is released to internal server components when the server is powered-on might cause the server to stop, which might result in the loss of data. To avoid this potential problem, always use an electrostatic-discharge wrist strap or other grounding system when working inside the server with the power on.

To install an adapter, complete the following steps:

1. Read the safety information that begins on page v and “Installation guidelines” on page 21.
2. Turn off the server and peripheral devices, and disconnect the power cords and all external cables. Remove the left-side cover.
3. See the documentation that comes with the adapter for any cabling instructions and information about jumper or switch settings. (It might be easier for you to route cables before you install the adapter.)
4. Open the front and rear adapter retention clips.
5. Remove the expansion-slot cover.

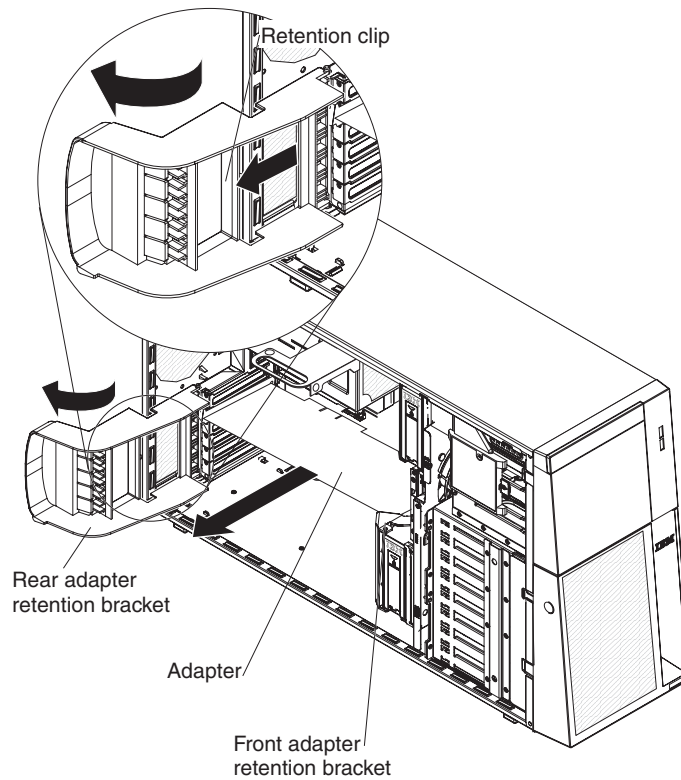

6. If you are installing a full-length adapter, remove the blue adapter guide (if any) from the end of the adapter; then, lift the adapter-retention clip on the adapter-support bracket. Otherwise, continue with the next step.

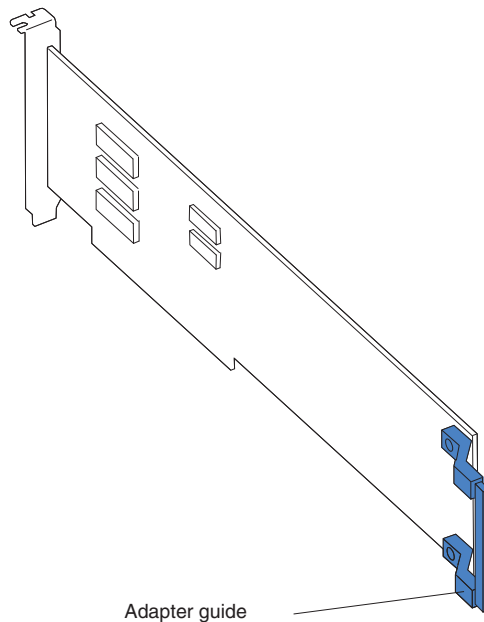

7. Press the adapter *firmly* into the expansion slot, lower the adapter-retention latch, and make sure that the latch is in the closed position.
Attention: Incomplete insertion might cause damage to the system board or the adapter.
8. Connect any needed cables to the adapter.

If you have other optional devices to install or remove, do so now. Otherwise, go to “Completing the installation” on page 49.

Installing the optional IBM ServeRAID-MR10is VAULT SAS/SATA Controller

The optional IBM ServeRAID-MR10is VAULT SAS/SATA controller can be installed only in its dedicated PCI slot 2 connector on the system board, and only in server models with eight 3.5-inch hot-swap hard disk drives. See “System-board internal connectors and switches” on page 14 for the location of the connector on the system board. The ServeRAID-MR10is SAS/SATA controller is not cabled to the system board. Instructions for routing the cables are described below.

To install the ServeRAID-MR10is SAS/SATA controller and route the cables, complete the following steps:

1. Read the safety information that begins on page v and “Installation guidelines” on page 21.
2. Turn off the server and peripheral devices, and disconnect the power cords and all external cables.
Attention: To avoid breaking the retaining clips or damaging the ServeRAID-MR10is SAS/SATA adapter connector, open and close the clips gently.
3. Remove the side cover (see “Removing the left-side cover” on page 24).
4. Rotate the rear adapter-retention bracket to the open (unlocked) position.
5. Remove the screw that secures the expansion-slot cover to the chassis (if no adapter is installed in the slot). Store the expansion-slot cover and screw in a safe place for future use.

Note: Expansion-slot covers must be installed on all vacant slots. This maintains the electronic emissions standards of the server and ensures proper ventilation of server components.

6. Open the retaining clips on each end of the ServeRAID-MR10is adapter connector.
7. Touch the static-protective package that contains the ServeRAID-MR10is adapter to any unpainted metal surface on the server; then, remove the ServeRAID-MR10is adapter from the package and place it on a static-protective surface.

8. Turn the ServeRAID-MR10is adapter so that the ServeRAID-MR10is adapter keys align correctly with the connector on the system board.

Attention: Incomplete insertion might cause damage to the system board or the ServeRAID-MR10is adapter.

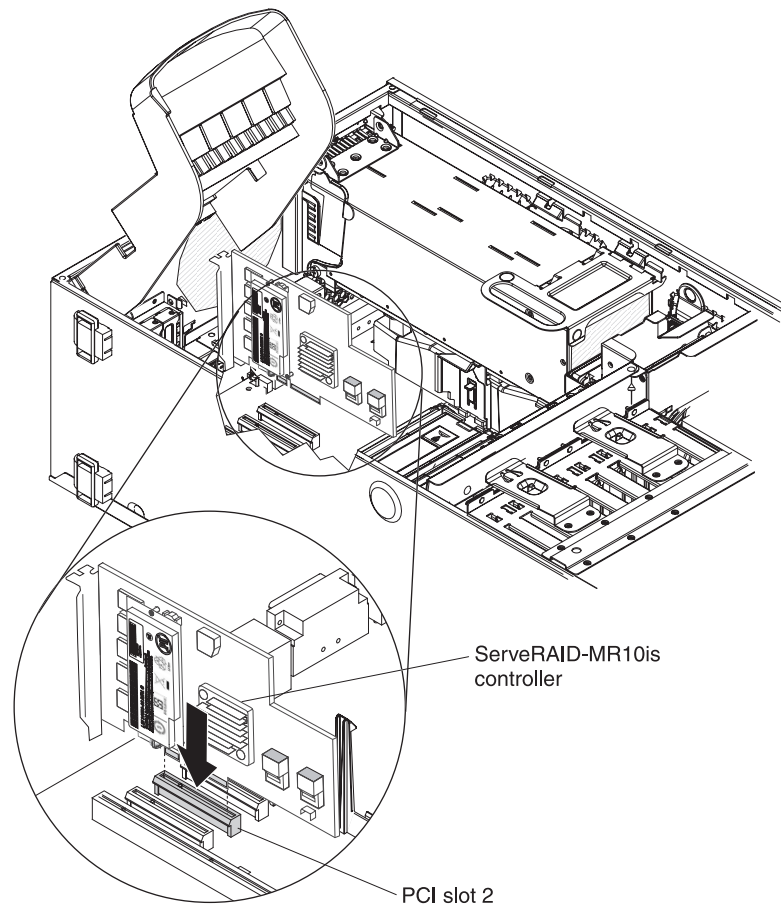

9. Press the ServeRAID-MR10is adapter firmly into the connector on the system board.
10. Rotate the power-supply cage assembly out of the chassis:
 - a. Remove the hot-swap power-supply. Press down on the orange release lever and pull the power supply out of the bay, using the handle.
 - b. Lift up the power-supply cage handle and pull the power-supply cage assembly all the way up until the retainer latch locks the cage in place on the chassis.
11. Remove the front fan cage assembly.
12. Take the other end of the signal cable that is attached to the drive backplane for drive bays 8 through 11 and route it through the plastic slot on the chassis underneath the front fan cage; then, connect it to connector J9 on the ServeRAID-MR10is SAS/SATA controller.

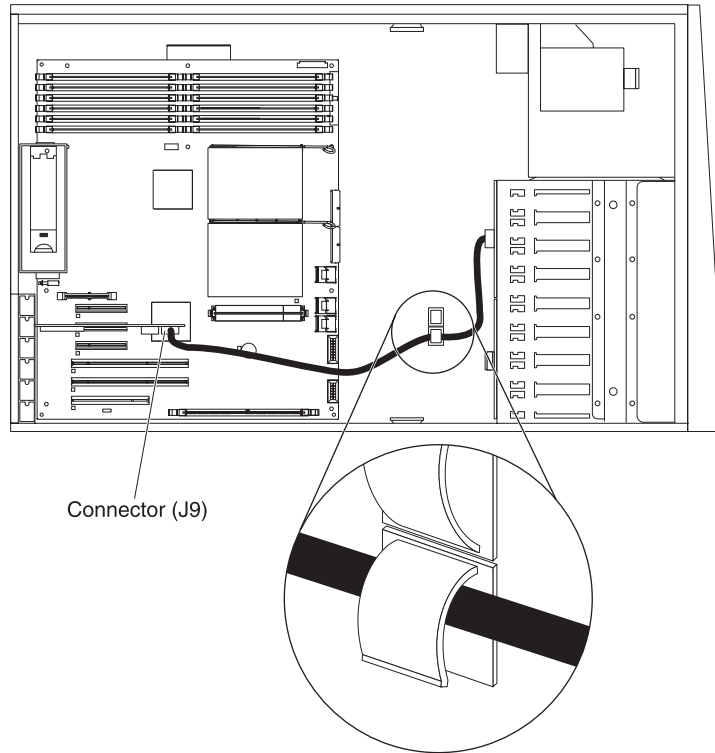

The following illustration shows the connectors on the controller to which you connect the signal cables from the drive backplanes.

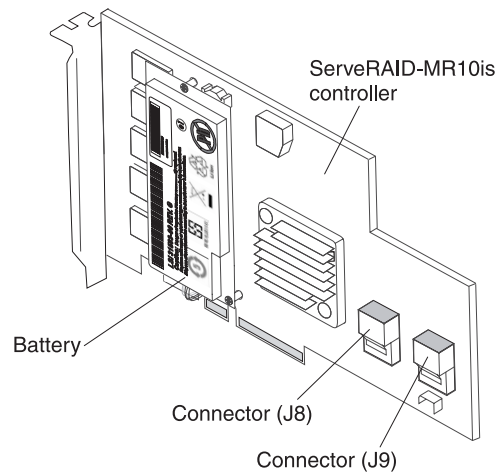

The following illustration shows which end of the cable connects to the backplane and to the controller.

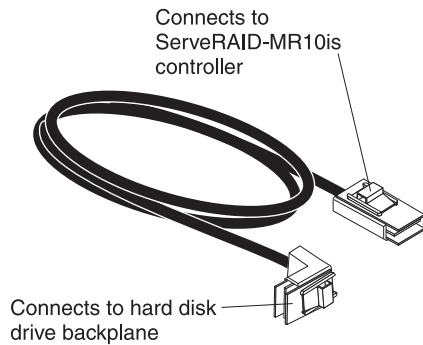

13. Reinstall the front fan cage assembly. Align the front fan cage assembly over the fan cage assembly slot and with the connector on the system board. Lower the fan cage assembly into the chassis and press down firmly until the fan cage assembly is seated firmly in place. Make sure that no cables will be pinched.
14. Take the other end of the signal cable that is attached to the drive backplane for drive bays 4 through 7 and route the cable around the right side of the front fan cage assembly and along the chassis wall (make sure that the cable is in front of the fan cage release tab): then, connect it to connector J8 on the ServeRAID-MR10is SAS/SATA controller.

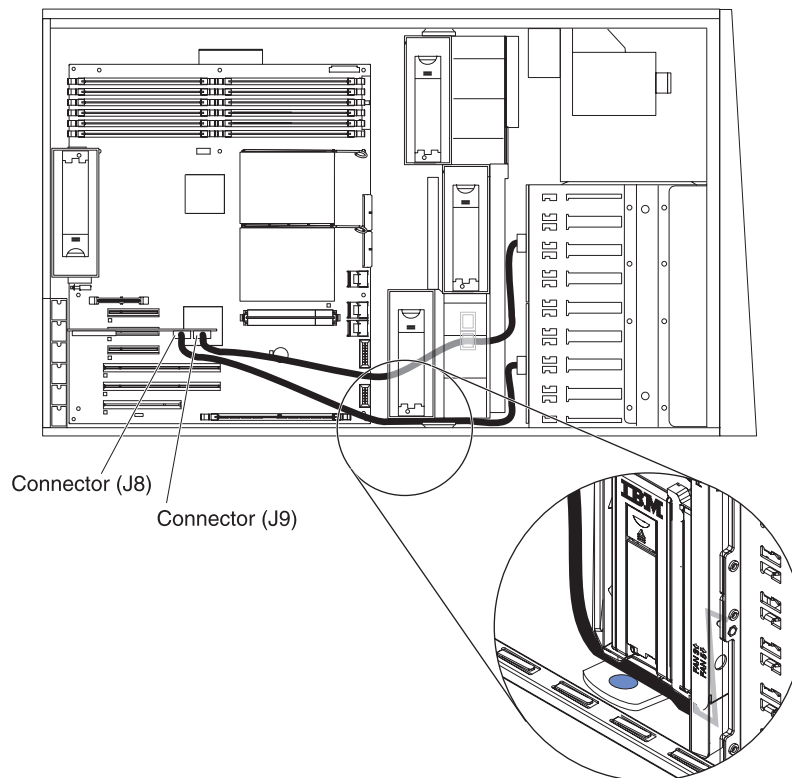

15. Rotate the rear adapter-retention bracket to the closed (locked) position.
16. Rotate the power-supply cage assembly back into the server. Press the power-supply cage release tab and rotate the power-supply cage assembly into the chassis.
17. Reinstall the hot-swap power supplies.
18. If you have other options to install or remove, do so now.

19. Replace the side cover and complete the installation (see “Completing the installation” on page 49.)

Installing a DVD drive

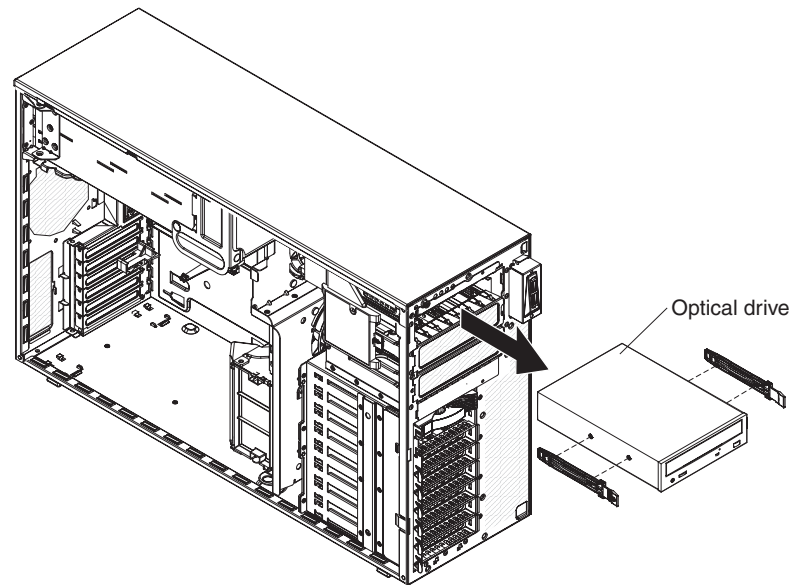

To remove a DVD drive, complete the following steps:

1. Read the safety information that begins on page v and “Installation guidelines” on page 21.
2. Turn off the server and peripheral devices, and disconnect the power cords and all external cables necessary to replace the device.
3. Unlock and remove the left-side cover (see “Removing the left-side cover” on page 24).
4. Press on the bezel retention tab at the center-left-edge of the bezel, and rotate the left side of the bezel away from the server; then, pull the bezel away from the server.
5. Disconnect the DVD drive cable from the system board.
6. Grasp the blue tabs on each side of the drive and press them inward while pulling the drive out of the server.

To install a DVD drive, complete the following steps:

1. Read the safety information that begins on page v and “Installation guidelines” on page 21.
2. Connect the DVD drive cable to the system board.
3. Slide the drive into the server to engage the drive.
4. Replace the left-side cover and bezel; then, lock the side cover and bezel.
5. Reconnect the external cables and power cords.

If you have other optional devices to install or remove, do so now. Otherwise, go to “Completing the installation” on page 49.

Installing a full-high tape drive

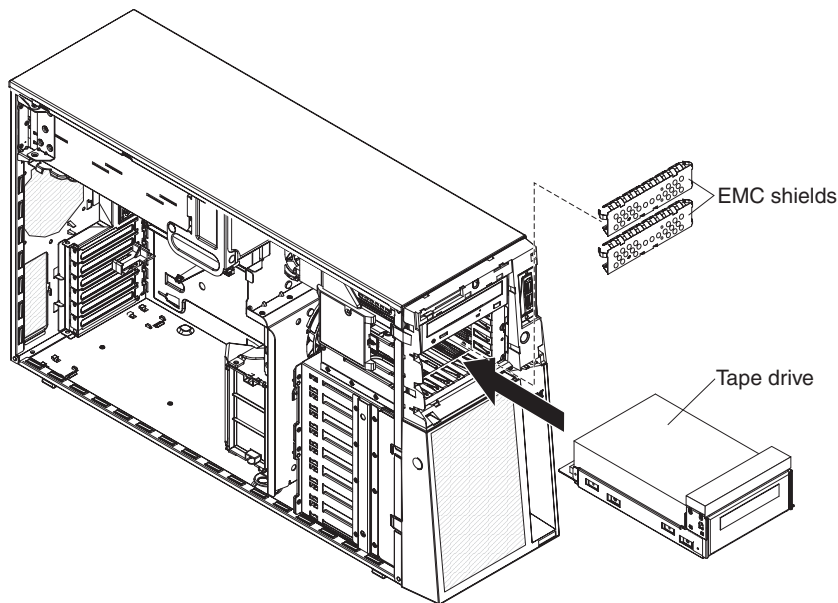

To install a full-high tape drive, complete the following steps:

1. Read the safety information that begins on page v and “Installation guidelines” on page 21.
2. Turn off the server and peripheral devices, and disconnect the power cords and all external cables necessary to replace the device.
3. Unlock and remove the left-side cover (see “Removing the left-side cover” on page 24).
4. Press on the bezel retention tab at the center-left-edge of the bezel, and rotate the left side of the bezel away from the server; then, pull the bezel away from the server.
5. Connect the full-high tape drive cable to the system board.
6. Slide the drive into the server and connect the IDE cable to the drive.
7. Using the supplied screws, secure the drive to the server chassis.
8. Replace the left-side cover and bezel; then, lock the side cover and bezel.
9. Reconnect the external cables and power cords.

If you have other optional devices to install or remove, do so now. Otherwise, go to “Completing the installation” on page 49.

Installing a USB tape drive

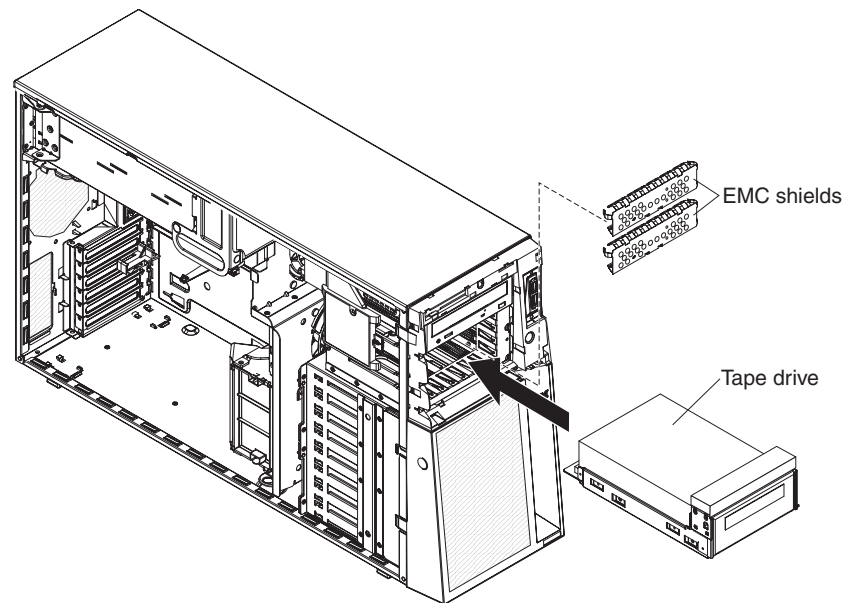

To install a USB tape drive, complete the following steps:

1. Read the safety information that begins on page v and “Installation guidelines” on page 21.
2. Turn off the server and peripheral devices, and disconnect the power cords and all external cables necessary to replace the device.
3. Unlock and remove the left-side cover (see “Removing the left-side cover” on page 24).
4. Remove the front fan cage assembly:
 - a. Press the fan cage release latches on each side of the fan cage toward the sides of the server. The cage will lift up slightly when the release latches are fully open.
 - b. Grasp the cage and lift it out of the server.
5. Press on the bezel retention tab at the center-left-edge of the bezel, and rotate the left side of the bezel away from the server; then, pull the bezel away from the server.
6. Slide the drive into the server.
7. Using the supplied screws, secure the drive to the server chassis.

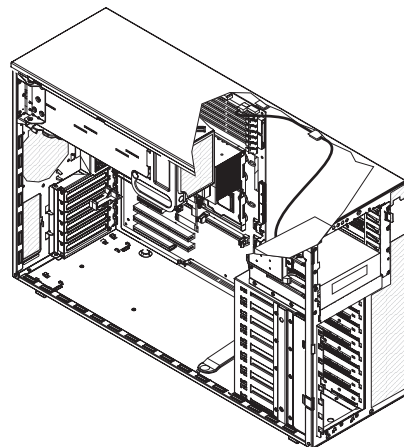

8. Connect one end of the tape drive USB cable to the USB connector on the system board; then, route the USB cable through the cable holders on the inside of the server and connect the opposite end of the cable to the USB tape drive.
9. Reinstall the front fan cage assembly.
10. Replace the left-side cover and bezel; then, lock the side cover and bezel.
11. Reconnect the external cables and power cords.

If you have other optional devices to install or remove, do so now. Otherwise, go to “Completing the installation” on page 49.

Installing a hot-swap hard disk drive

The following notes describe the types of hard disk drives that the server supports and other information that you must consider when you install a hard disk drive:

- Depending on the model, the server supports up to eight 1-inch (26 mm) slim high, 3.5-inch SAS/SATA hot-swap hard disk drives or up to twelve 1-inch (26 mm) slim-high, 2.5-inch, SAS/SATA hot-swap hard disk drives in the standard hot-swap bays.
- The hot-swap bays are arranged vertically in the standard hard disk drive cage; the bay numbers are 0 through 7 (from top to bottom) on models with eight hard disk drives and 0 through 11 (from top to bottom) on models with 12 hard disks.
- For a list of supported optional devices for the server, see <http://www.ibm.com/servers/eserver/serverproven/compat/us/>.
- Inspect the drive tray for signs of damage.
- Make sure that the drive is correctly installed in the tray.
- See the documentation for the ServeRAID-8k, ServeRAID-8s, and the optional ServeRAID-10i SAS Controllers for instructions for installing a hard disk drive.
- All hot-swap drives in the server must have the same throughput speed rating; using drives with different speed ratings might cause all drives to operate at the throughput of the slowest drive.
- To minimize the possibility of damage to the hard disk drives when you are installing them in a rack configuration, install the server in the rack before you install the hard disk drives.
- You do not have to turn off the server to install hot-swap drives in the hot-swap drive bays. However, you must turn off the server when you perform any steps that involve installing or removing cables.
- The drive ID for each hot-swap hard disk drive is printed on the bezel.

To remove a hot-swap hard disk drive, complete the following steps.

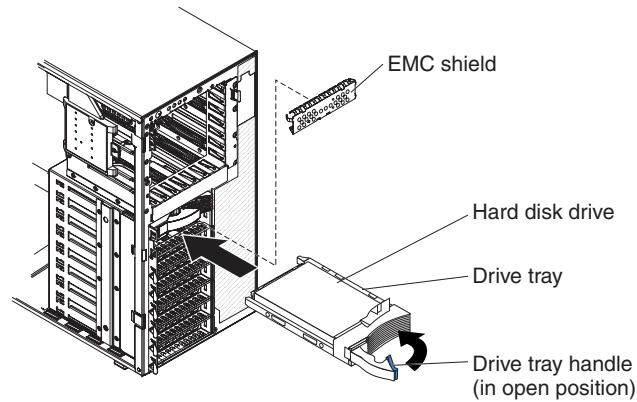

1. Read the safety information that begins on page v and “Installation guidelines” on page 21.
2. Remove the bezel from the server.
3. Open the drive tray handle and pull the drive out of the server.

To install a hot-swap hard disk drive, complete the following steps:

1. Read the safety information that begins on page v and “Installation guidelines” on page 21.
2. Remove the filler panel from one of the empty hot-swap bays.
3. Make sure that the tray handle is open; then, install the hard disk drive into the hot-swap bay.

Notes:

1. When you turn on the server, check the hard disk drive status LEDs to verify that the hard disk drive is operating correctly.
If the amber hard disk drive status LED is lit continuously, that drive is faulty and must be replaced. If the green hard disk drive activity LED is flashing, the drive is being accessed.
2. If the server is configured for RAID operation using an optional ServeRAID adapter, you might have to reconfigure your disk arrays after you install hard disk drives. See the ServeRAID documentation on the *IBM ServeRAID Support* CD for additional information about RAID operation and complete instructions for using ServeRAID Manager.

If you have other optional devices to install or remove, do so now. Otherwise, go to “Completing the installation” on page 49.

Installing an IBM Remote Supervisor Adapter II SlimLine

An optional IBM Remote Supervisor Adapter II SlimLine can be installed only in its dedicated connector on the system board. The Remote Supervisor Adapter II SlimLine is not cabled to the system board.

To install a Remote Supervisor Adapter II SlimLine, complete the following steps:

1. Read the safety information that begins on page v and “Installation guidelines” on page 21.
2. Turn off the server and peripheral devices, and disconnect the power cords and all external cables.
3. Remove the left-side cover.

- Carefully lay the server on its right side.

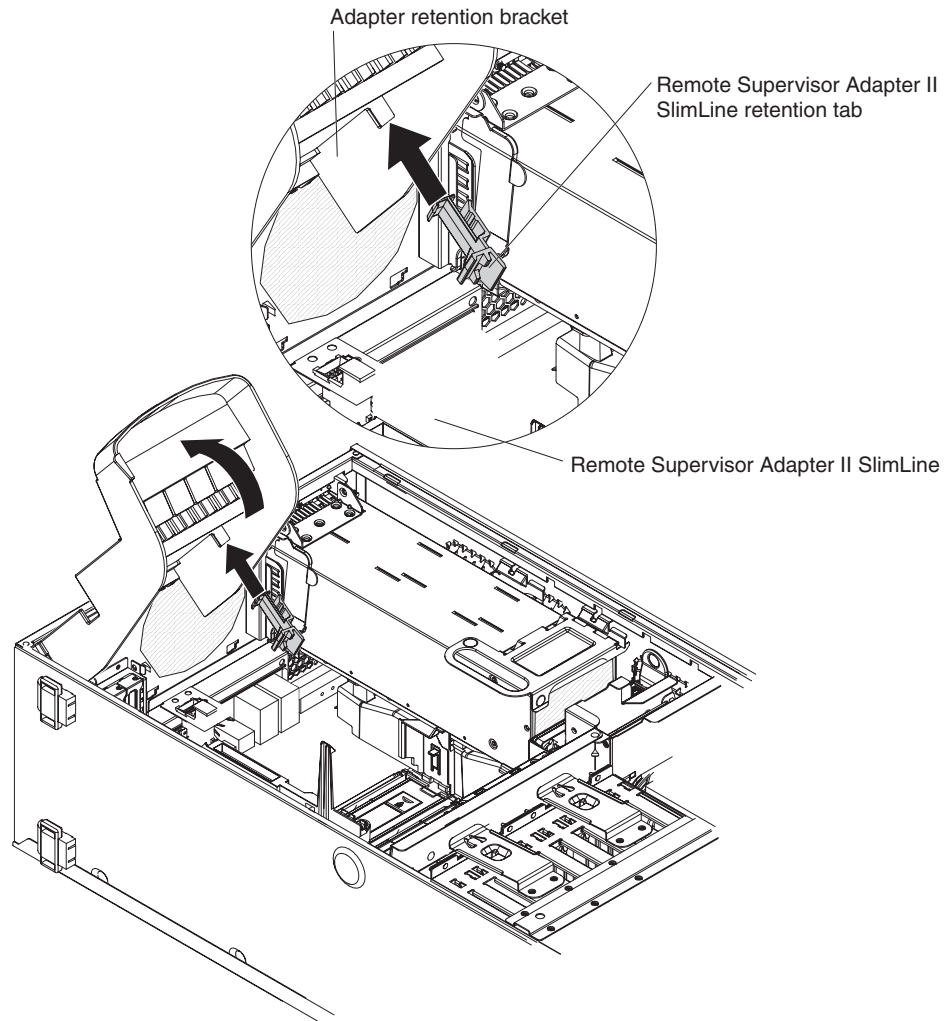

- Open the rear adapter retention bracket and install the Remote Supervisor Adapter II SlimLine retention tab on the bracket by clipping it onto the rear adapter retention bracket.

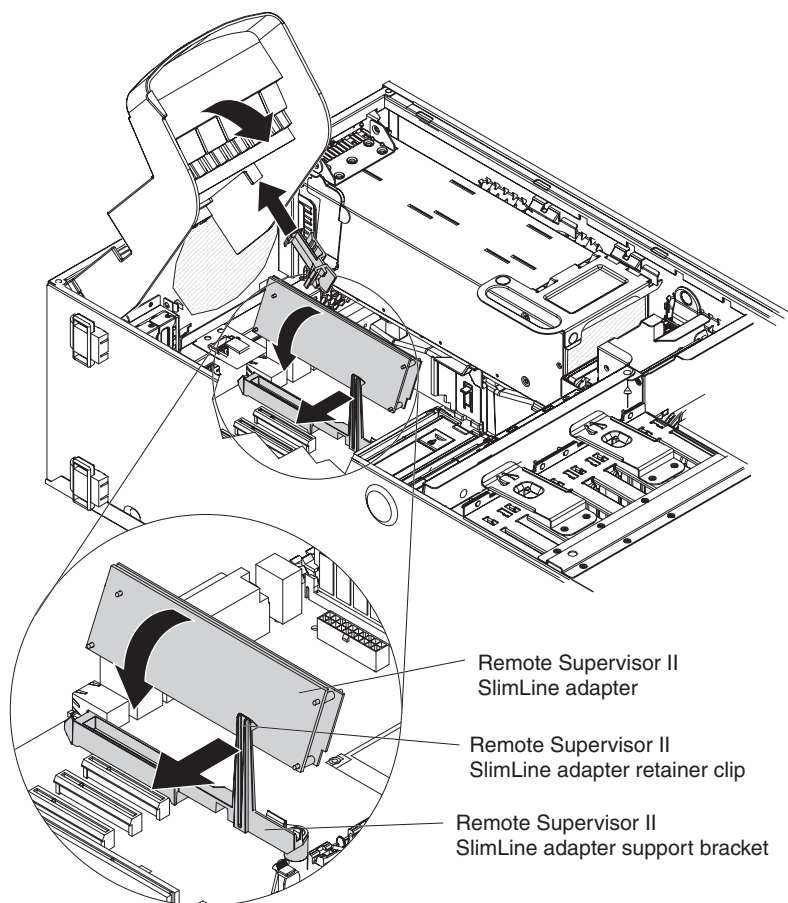

6. Carefully grasp the Remote Supervisor Adapter II SlimLine by its top edge or upper corners, and align it with the Remote Supervisor Adapter II SlimLine guide and the connector on the system board.

Attention: Incomplete insertion might cause damage to the system board or the adapter.

7. Press the Remote Supervisor Adapter II SlimLine *firmly* into the connector and under the retention clip on the Remote Supervisor Adapter II SlimLine support bracket.
8. Close the rear adapter retention bracket.

If you have other optional devices to install or remove, do so now. Otherwise, go to “Completing the installation” on page 49.

Installing a memory module

The following notes describe the types of dual inline memory modules (DIMMs) that your server supports and other information that you must consider when you install DIMMs:

- The server supports up to twelve 667 MHz, 1.8 V, 240-pin, PC2-5300 double-data-rate (DDR) II, fully buffered synchronous dynamic random-access memory (SDRAM) with error correcting code (ECC) DIMMs. These DIMMs must be compatible with the latest 5300 SDRAM Fully Buffered DIMM (FBD) specification. For a list of supported optional devices for the server, see <http://www.ibm.com/servers/eserver/serverproven/compat/us/>.
- At least one pair of DIMMs must be installed for the server to operate.

- When you install additional DIMMs, be sure to install them in pairs. All the DIMM pairs must be the same size and type.
- The memory controller has four fully buffered DIMM channels that are organized into two branches. Each branch has two channels, and each channel controls two DIMMs. DIMMs that are next to each other (for example, in DIMM connector 1 and DIMM connector 4) within the channels of a branch must be identical in size, type, speed, and technology. However, the DIMMs in the connectors above or below each other within the channels of a branch do not have to be identical (for example, the DIMMs in DIMM connector 1 and DIMM connector 2 do not have to be identical). The following illustration shows how the memory controller is organized into branches and channels with two pairs of installed DIMMs.
- You do not have to save new configuration information when you install or remove DIMMs.

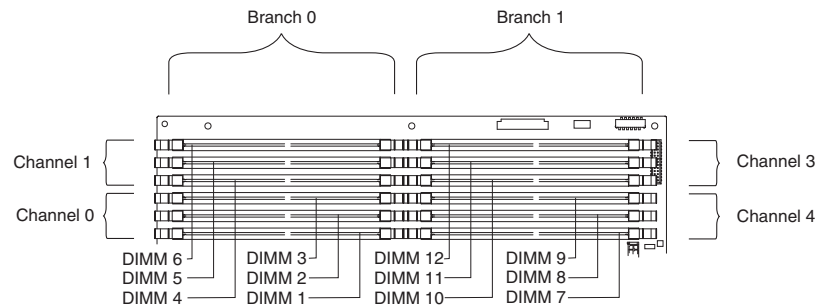

- The 12 DIMM connectors are divided between the two memory branches. DIMM connectors 1 through 6 are on branch 0, and DIMM connectors 7 through 12 are on branch 1.
- The server can operate in two major modes: mirroring and non-mirroring (normal). The server can also operate in a single-channel mode when one DIMM is installed.
- The server supports memory mirroring (mirroring mode) and online-spare memory.
 - Memory mirroring replicates and stores data on DIMMs within two branches simultaneously. You must enable memory mirroring through the Configuration/Setup Utility program (see “Using the Configuration/Setup Utility program” on page 54). To enable memory mirroring in the Configuration/Setup Utility program, select **Devices and I/O Ports** → **Advanced Chipset Control** → **Memory Branch Mode**. Use the arrow keys to change the **Memory Branch Mode** setting to **Mirror**; then, save your changes. When you use memory mirroring, consider the following information:
 - The maximum available memory is reduced to 16 GB, instead of the 32 GB available in non-mirroring mode.
 - The minimum memory configuration is four identical DIMMs. You must install identical pairs of fully buffered, dual-inline memory modules (DIMMs) in all four DIMM connectors (same size, type, speed, and technology). These DIMMs must span across both branches and all four channels. For example, when you install the first four DIMMs, you must install two DIMMs in branch 0 (one in channel 0 and one in channel 1) and two DIMMs in branch 1 (one in channel 2 and one in channel 3). See Table 3 on page 39 for the DIMM installation sequence.
 - When you upgrade the server to eight DIMMs, the DIMMs that are next to each other (for example, DIMM connector 1 and DIMM connector 4) within the channels of a branch must be identical in size, type, speed, and technology. However, the DIMMs in the connectors above or below each

other within the channels of a branch do not have to be identical to each other (for example, the DIMMs in DIMM connector 1 and DIMM connector 2).

- Both branches operate in dual-channel mode.

The following table shows the DIMM configuration upgrade sequence for operating in mirroring mode.

Table 3. DIMM upgrade configuration sequence in mirroring mode

Number of DIMMs	DIMM connectors
4	1, 4, 7, 10
8	1, 4, 7, 10, 2, 5, 8, 11
12	1, 4, 7, 10, 2, 5, 8, 11, 3, 6, 9, 12

- Online-spare memory disables a failed rank pair of DIMMs from the system configuration and activates an online-spare rank pair of DIMMs to replace the failed rank pair of DIMMs. For an online-spare pair of DIMMs to be activated, you must enable this feature and have installed an additional rank pair of DIMMs of the same speed, type, size (or larger), and technology as the failed pair of DIMMs. You must enable the feature through the Configuration/Setup Utility program. To enable online-spare memory in the Configuration/Setup Utility program, select **Devices and I/O Ports** → **Advanced Chipset Control** → **Memory Branch Mode**. Use the arrow keys to change the setting for **Branch 0 Rank Sparing** or **Branch 1 Rank Sparing** to **Enabled**; then, save your changes. See “Using the Configuration/Setup Utility program” on page 54 for additional information. When you use online-spare memory, you must consider the following information:
 - You cannot enable online-spare memory while the server is operating in mirroring mode.
 - When you use online-spare memory, the two memory branches operate independently of each other. You can enable online-spare memory for one or both branches.
 - Online-spare memory reduces the amount of available memory.
 - Online-spare DIMM pairs are assigned according to your DIMM configuration.
 - Online-spare memory works by copying data from a failed DIMM rank to another good DIMM rank within the same memory branch.
 - Online-spare memory cannot copy data from one branch to the other.

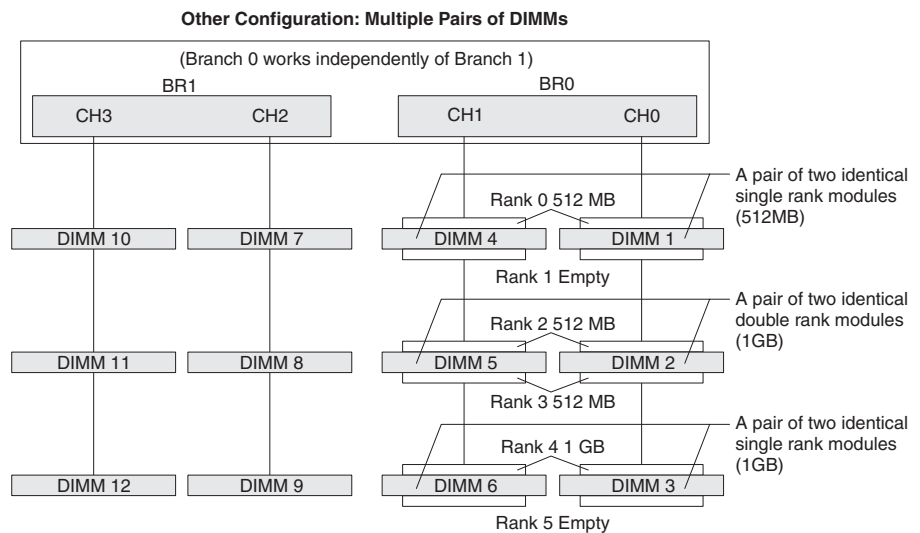
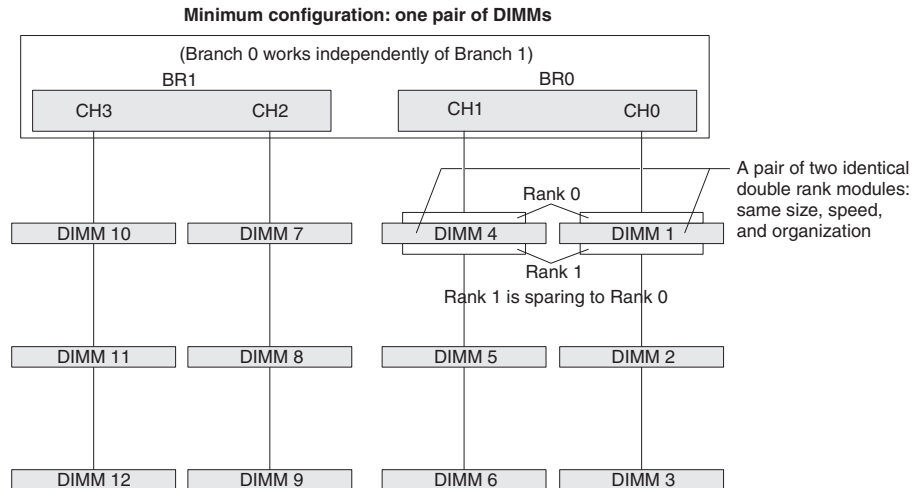

Rank 4 is used to spare any defective rank of rank 0, 2, and 3

- A rank is defined as an area or block of 64 bits that is created by using some or all of the chips on a DIMM. For an ECC DIMM, a memory rank is a block of 72 data bits (64 bits plus 8 ECC bits).
- The minimum memory configuration is two single-rank DIMMs that are installed in branch 0, DIMM connector 1 (in channel 0) and connector 4 (in channel 1); however, online-sparing is not supported with this configuration.
- To support online-sparing in branch 0, you must add a second pair of DIMMs. The spare pair of DIMMs can be single-rank or double-rank and must be the same speed, type, size (or larger), and technology as the failed pair of DIMMs. The spare pair must be installed in branch 0, DIMM connector 2 (in channel 0) and connector 5 (in channel 1). Branch 0 and branch 1 operate independently.
- The following notes apply when the server operates in non-mirroring mode (normal mode):
 - DIMMs must be installed in matched pairs. If you install a second pair of DIMMs in DIMM connector 7 and DIMM connector 10, they do not have to be the same size, speed, type, and technology as the DIMMs in DIMM connector

1 and DIMM connector 4. However, the size, speed, type, and technology of the DIMMs that you install in DIMM connector 7 and DIMM connector 10 must match each other.

- The following table shows the DIMM upgrade configuration sequence for operating in non-mirroring mode (normal mode).

Table 4. 5. DIMM upgrade configuration sequence in non-mirroring mode

Number of DIMMs	DIMM connectors
2	1, 4
4	1, 4, 7, 10
6	1, 4, 7, 10, 2, 5
8	1, 4, 7, 10, 2, 5, 8, 11
10	1, 4, 7, 10, 2, 5, 8, 11, 3, 6
12	1, 4, 7, 10, 2, 5, 8, 11, 3, 6, 9, 12

- The amount of usable memory is reduced depending on the system configuration. A certain amount of memory must be reserved for system resources. To view the total amount of installed memory and the amount of configured memory, run the Configuration/Setup Utility program and select **System Summary** from the menu. For additional information, see Chapter 3, “Configuring the server,” on page 53.
- The following tables show examples of maximum memory capacity when the server operates in mirroring and non-mirroring modes, using identical single-rank, x8 technology or double-rank, x4 technology DIMMs. The memory capacity is dependent on the size and technology of the DIMMs that you install.

Table 5. Example of the memory capacity when identical x8 technology single-rank DIMMs are used

DIMMs installed	x8 single-rank technology	Memory available in mirroring mode	Memory available in non-mirroring mode
8	512 MB	2 GB	4 GB
8	1 GB	4 GB	8 GB
8	2 GB	8 GB	16 GB

Table 6. Example of the memory capacity when identical x4 technology double-rank DIMMs are used

DIMMs installed	x4 double-rank technology	Memory available in mirroring mode	Memory available in non-mirroring mode
8	512 MB	8 GB	16 GB
8	1 GB	16 GB	32 GB

- When you restart the server after you add or remove a DIMM, the server displays a message that the memory configuration has changed.
- If a problem with a DIMM is detected, light path diagnostics lights the system-error LED on the front of the server, indicating that there is a problem, and guides you to the defective DIMM. When this occurs, first identify the defective DIMM; then, remove and replace the DIMM.

Attention: Static electricity that is released to internal server components when the server is powered-on might cause the server to stop, which might result in the loss of data. To avoid this potential problem, always use an electrostatic-discharge wrist strap or other grounding system when you work inside the server with the power on.

The following illustration shows how to install DIMMs on the system board.

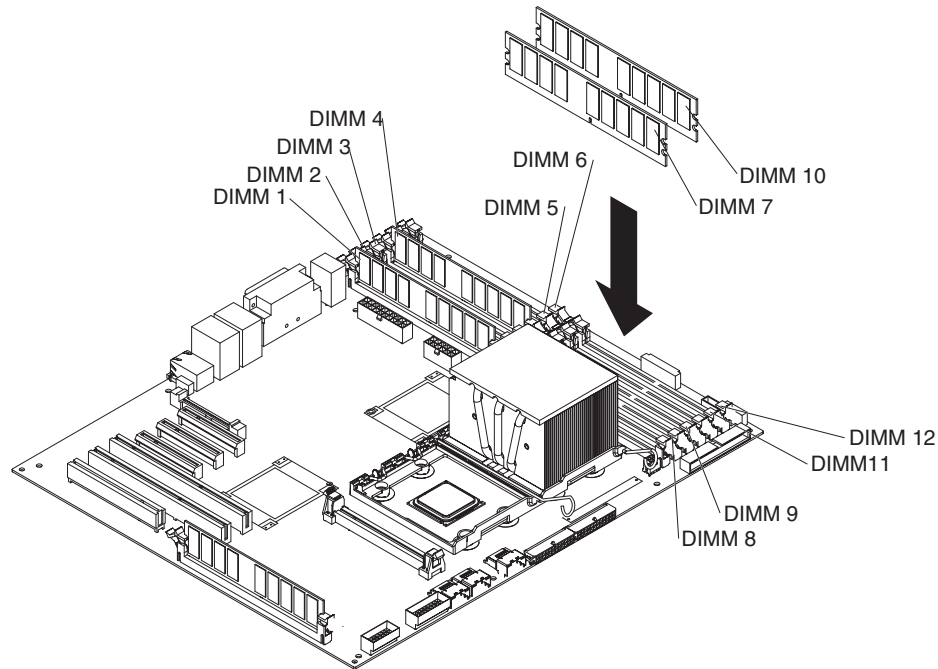

To remove a DIMM, complete the following steps:

1. Read the safety information that begins on page v and “Installation guidelines” on page 21.
2. Turn off the server and peripheral devices, and disconnect the power cords and all external cables.
3. Remove the power supply or power supplies from the server.
4. Raise the power-supply cage out of the way:
 - a. Press in on the power-supply latch bracket, which is on the left side of the server when you are facing the rear of the server.
 - b. Lift the end of the power-supply cage and rotate the cage up until it stops. The tab on the rear power-supply latch bracket clicks into place when the cage is completely out of the way.
 - c. Let the power-supply cage rest on the rear power-supply latch bracket.

Attention: To avoid breaking the DIMM retaining clips or damaging the DIMM connectors, open and close the clips gently.

5. Open the retaining clip on each end of the DIMM connector; then, remove the DIMM from the server.

To install a DIMM, complete the following steps:

1. Read the safety information that begins on page v and “Installation guidelines” on page 21.
2. Turn off the server and peripheral devices; then, disconnect the power cords and all external cables. Remove the cover.

3. Remove the power supply or power supplies from the server.
4. Raise the power-supply cage out of the way:
 - a. Press in on the power-supply latch bracket, which is on the left side of the server when you are facing the rear of the server.
 - b. Lift the end of the power-supply cage and rotate the cage up until it stops. The tab on the rear power-supply latch bracket clicks into place when the cage is completely out of the way.
 - c. Let the power-supply cage rest on the rear power-supply latch bracket.

Attention: To avoid breaking the DIMM retaining clips or damaging the DIMM connectors, open and close the clips gently.

5. Open the retaining clip on each end of the DIMM connector.
6. Touch the static-protective package containing the DIMM to any unpainted metal surface on the outside of the server. Then, remove the DIMM from the package.

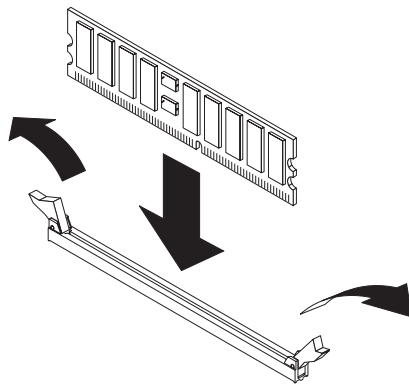

7. Turn the DIMM so that the DIMM keys align correctly with the connector.
8. Insert the DIMM into the connector by aligning the edges of the DIMM with the slots at the ends of the DIMM connector. Firmly press the DIMM straight down into the connector by applying pressure on both ends of the DIMM simultaneously. The retaining clips snap into the locked position when the DIMM is firmly seated in the connector. If there is a gap between the DIMM and the retaining clips, the DIMM has not been correctly inserted; open the retaining clips, remove the DIMM, and then reinsert it.

If you have other optional devices to install or remove, do so now. Otherwise, go to “Completing the installation” on page 49.

Installing a microprocessor

The following notes describe the type of microprocessor that the server supports and other information that you must consider when you install a microprocessor:

- For a list of supported optional devices for the server, go to <http://www.ibm.com/us/compat/>.
- The server supports Intel Xeon dual-core or quad-core 1.6 GHz or higher microprocessors in each socket. If you are installing two microprocessors, they must be the same cache size and type, and the same clock speed.
- Some models support dual-core processors and quad-core processors. Do not use dual-core processors and quad-core processors in the same system. Install all dual-core or all quad-core processors in the server.
- To ensure that the server operates correctly, use microprocessors that have the same cache and type, and the same clock speed. The microprocessor internal

and external clock frequencies must be identical. You can use the Configuration/Setup Utility program to determine the specific type of microprocessor that is installed on the system board.

- Read the documentation that comes with the microprocessor to determine whether you must update the basic input/output system (BIOS) code in the server. To download the most current level of BIOS code for the server, see <http://www.ibm.com/support/>.
- Obtain an SMP-capable operating system. For a list of supported operating systems, see <http://www.ibm.com/servers/eserver/serverproven/compat/us/>.
- You can use the Configuration/Setup Utility program to determine the specific type of microprocessor in the server.

To install a microprocessor, complete the following steps:

1. Read the safety information that begins on page v and “Installation guidelines” on page 21.
2. Turn off the server and peripheral devices; then, disconnect the power cords and all external cables. Remove the cover.

Attention: The microprocessor retention latch is spring-loaded when the microprocessor is in place. Releasing the latch too quickly or allowing it to spring upward can damage the microprocessor and surrounding components.

3. Remove the microprocessor air duct from the fan cage:
 - a. Grasp the two pinch points on the top of the air duct and squeeze them together.
 - b. Lift the air duct up and out of the server and set it aside.
4. Release the microprocessor retention latch by pressing down on the end, moving it to the side, and slowly releasing it to the open (up) position.

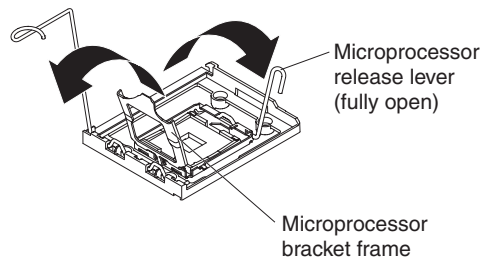

5. Open the microprocessor bracket frame by lifting up the tab on the top edge.

Attention: Dropping the microprocessor during removal or installation can damage the contacts. Also, contaminants on the microprocessor contacts, such as oil from your skin, can cause connection failures between the contacts and the socket.
6. Install the microprocessor:
 - a. Touch the static-protective package that contains the microprocessor to any unpainted metal surface on the server. Then, remove the microprocessor from the package.
 - b. Remove the protective cover, tape, or label from the surface of the microprocessor socket, if any is present.
 - c. Align the microprocessor with the socket. The microprocessor has two notches that are keyed to two tabs on the sides of the socket. A triangle-shaped indicator on one corner of the microprocessor points to a 45-degree angle on one corner of the socket.
 - d. Carefully place the microprocessor into the socket. Do not use excessive force when pressing the microprocessor into the socket.

7. Close the microprocessor bracket frame; then, close the microprocessor retention latch and lock it securely in place.

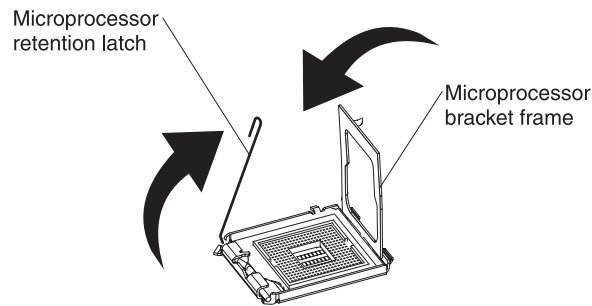

8. Close the microprocessor-release lever to secure the microprocessor.
9. Make sure that the heat-sink release lever is open.
10. If necessary, remove the cover from the bottom of the heat sink.
11. Place the tab on the heat sink into the connector in the retention bracket; then, rotate the heat sink into place and close the heat-sink release lever.

Note: If you are installing an additional microprocessor in microprocessor socket 2, you must also install a VRM.

12. If necessary, install a VRM in the connector.
 - a. Open the retaining clips on each end of the VRM connector.
 - b. Turn the VRM so that the keys align with the connector.
 - c. Insert the VRM into the connector by aligning the edges of the VRM with the slots at the end of the VRM connector. Firmly press the VRM straight down into the connector by applying pressure on both ends of the VRM simultaneously. The retaining clips snap into the locked position when the VRM is seated in the connector.
13. Reinstall the microprocessor air duct.
14. Reinstall the left-side cover.
15. Reconnect external cables and power cords.

If you have other optional devices to install or remove, do so now. Otherwise, go to “Completing the installation” on page 49.

Installing redundant power and cooling

You can install a second 835-watt hot-swap power-supply. This upgrade option includes a hot-swap power supply, two hot-swap fans, a fan structure with an air duct and a single hot-swap fan. You must also purchase a second power cord to connect the power-supply to the power source.

To install the redundant power and cooling option, complete the following steps:

1. Read the safety information that begins on page v and “Installation guidelines” on page 21.
2. Turn off the server and peripheral devices, and disconnect the power cords and all external cables. Remove the left-side cover.
3. Remove all adapters.

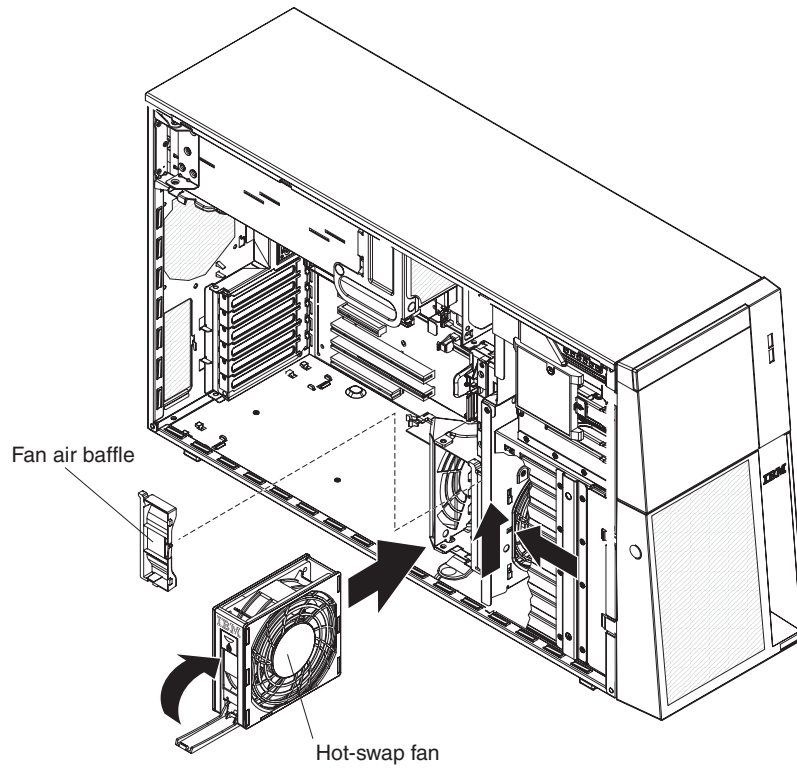

4. Remove the fan air baffle from the fan cage assembly by pushing in on the tab on the back of the air baffle; then, push the baffle to the left and lift it out of the fan cage assembly.
5. Install two hot-swap fans in the empty bays of the fan cage assembly.

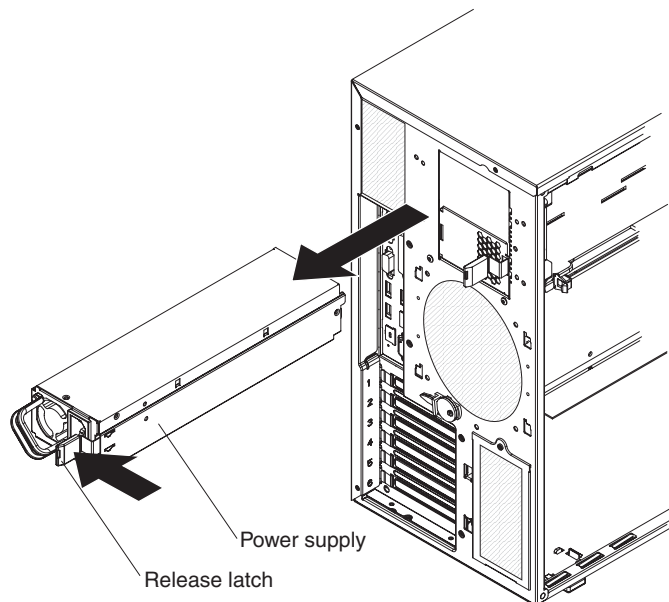

6. Remove the power supply and power-supply filler from the server by pressing down on the release latch while you pull them out.

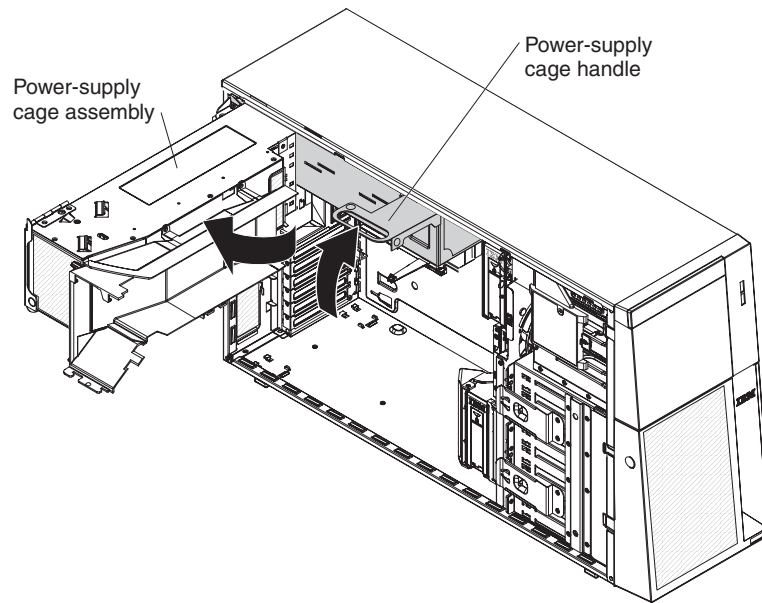

7. Lift the power-supply cage handle on the rear of the power-supply cage, and rotate the power-supply cage out of the way until it latches in place. Let the power-supply cage rest on the rear power-supply structure support bracket.
8. Install the transition duct on the edge of the DIMM air baffle.

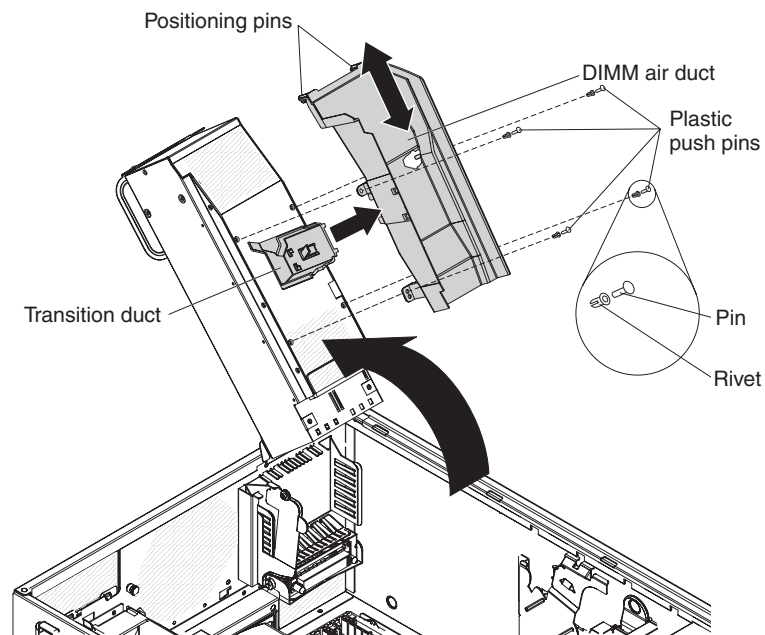

- a. Remove the four screws that secure the DIMM air baffle to the power-supply cage.
 - b. Push the DIMM air baffle toward the rear of the server until the positioning pins on the DIMM air baffle are clear of the holes in the power-supply cage.
 - c. Position the transition duct so that the two tabs are directly over the slots on the side of the DIMM air baffle.
 - d. Slide the transition duct into the slots until it clicks into place.
9. Reinstall the DIMM air baffle onto the power-supply cage.

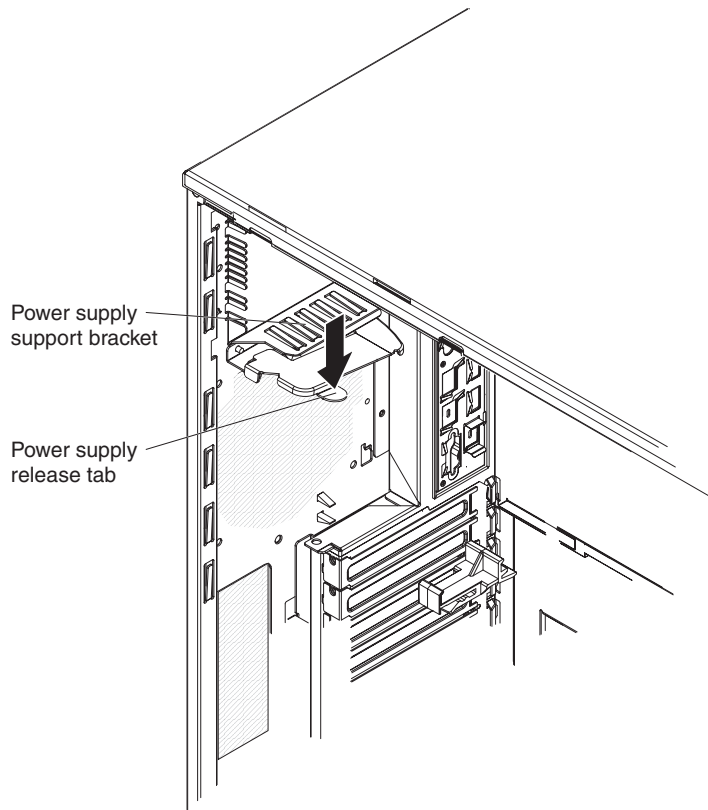

10. Raise the power-supply cage slightly and press and hold the release tab on the rear power-supply support bracket; then, lower the power-supply structure into position. For clarity, the power-supply cage is not shown in the illustration.

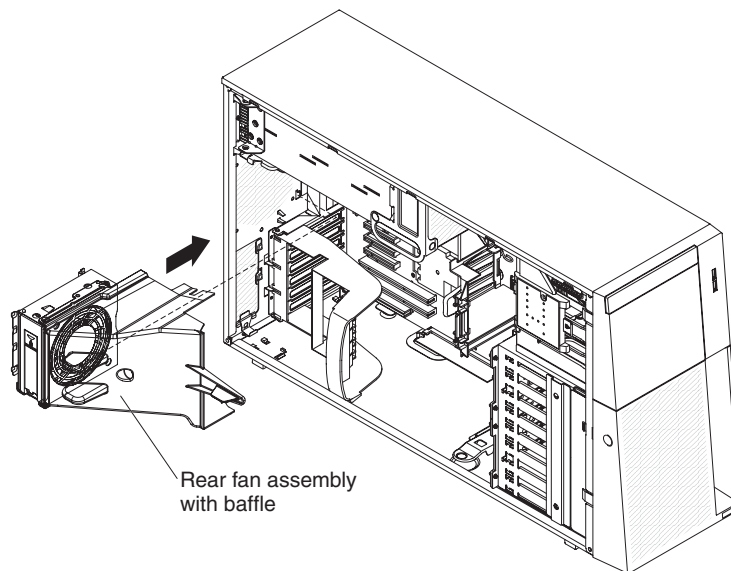

11. Install the rear fan and fan structure on the chassis:
 - a. Align the clips on the rear fan assembly with the holes in the chassis.
 - b. Slide the assembly toward the power-supply cage until it stops.

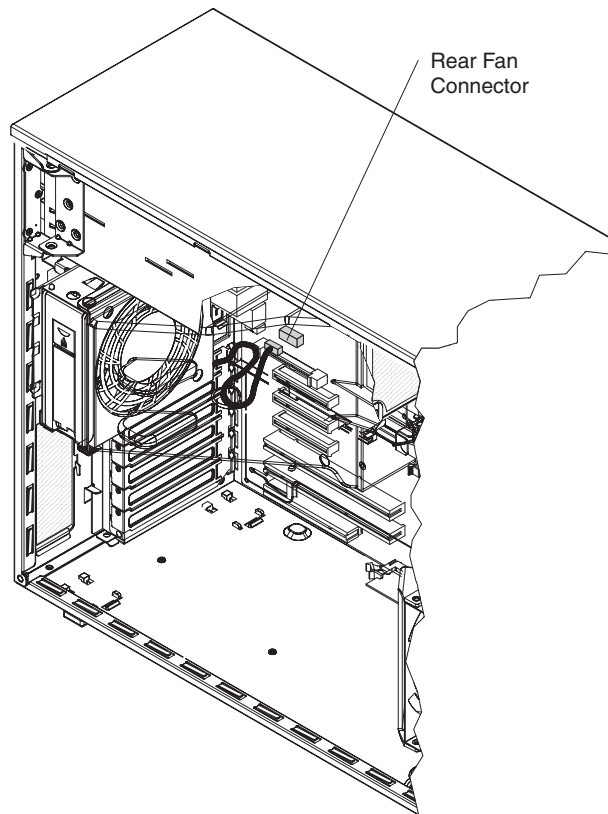

- c. Connect the fan power cable to the connector on the system board.
12. Install the adapters.
13. Install the left-side cover.
14. Install the power supplies into the server. Push each power supply until it stops and clicks into place.
15. Connect one end of each power cord into the connector on the back of each power supply, and connect the other end of each power cord to a properly grounded electrical outlet.
16. Make sure that the ac power LED on the top of each power supply is lit, indicating that the power supply is operating correctly. If the server is turned on, make sure that the dc power LED on the top of the power supply is lit also.
17. Reconnect the external cables.

If you have other optional devices to install or remove, do so now. Otherwise, go to “Completing the installation.”

Completing the installation

To complete the installation, complete the following steps:

1. Insert the bezel hinges into the slots on the server chassis and close the bezel.
2. Position the left-side cover over the server with the handle away from you.
3. Place the bottom edge of the cover onto the bottom edge of the server.
4. Rotate the top edge of left-side cover toward the server; then, press down on the cover until it clicks into place.
5. Rotate the bezel to its fully closed position.
6. Using the supplied key, lock the left-side cover and bezel.

7. Connect the cables and power cords. For more information, see “Connecting the cables.”

Connecting the cables

Notes:

1. Be sure to turn off the server before you connect any cables to or disconnect any cables from the server or hot-plug adapter.
2. For additional cabling instructions, see the documentation that comes with the optional devices. It might be easier for you to route any cables before you install certain optional devices.
3. Cable identifiers are printed on the cables that come with the server and optional devices. Use these identifiers to connect the cables to the correct connectors. For example, the hard disk drive cables are labeled “HDD option.”

The following illustration shows the locations of the input and output connectors on the rear of the server.

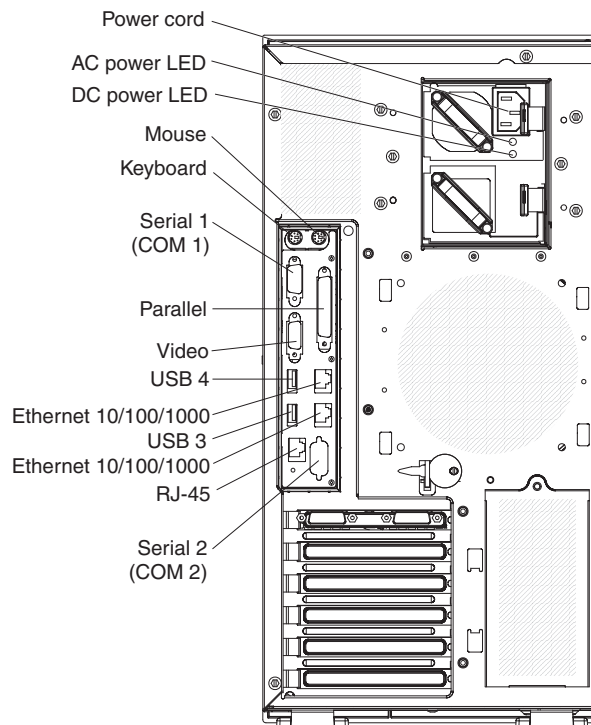

Updating the server configuration

When you start the server for the first time after you add or remove a device, you might receive a message that the configuration has changed. The Configuration/Setup Utility program starts automatically so that you can save the new configuration settings. For more information, see Chapter 3, “Configuring the server,” on page 53.

Some optional devices have device drivers that you must install. For information about installing device drivers, see the documentation that comes with each device.

The server comes with at least one microprocessor. If more than one microprocessor is installed, the server can operate as a symmetric multiprocessing (SMP) server. You might have to upgrade the operating system to support SMP. For

more information, see “Using the ServerGuide Setup and Installation CD” on page 59 and the operating-system documentation.

If the server has an optional RAID adapter and you have installed or removed a hard disk drive, see the documentation that comes with the RAID adapter for information about reconfiguring the disk arrays.

If you have installed a Remote Supervisor Adapter II SlimLine to manage the server remotely, see the *Remote Supervisor Adapter User's Guide*, which comes with the adapter, for information about setting up, configuring, and using the adapter.

For information about configuring the integrated Gigabit Ethernet controller, see “Configuring the Broadcom Gigabit Ethernet controller” on page 74.

Chapter 3. Configuring the server

The following configuration programs come with the server:

- **Configuration/Setup Utility program**

The Configuration/Setup Utility program is part of the basic input/output system (BIOS). Use it to configure serial port assignments, change interrupt request (IRQ) settings, change the startup-device sequence, set the date and time, and set passwords. For information about using this utility program, see “Using the Configuration/Setup Utility program” on page 54.

- **IBM ServerGuide Setup and Installation CD**

The ServerGuide program provides software-setup tools and installation tools that are designed for the server. Use this CD during the installation of the server to configure basic hardware features, such as an integrated SAS controller with RAID capabilities, and to simplify the installation of the operating system. For information about using this CD, see “Using the ServerGuide Setup and Installation CD” on page 59.

- **Baseboard management controller**

Use these programs to configure the baseboard management controller, to update the firmware and sensor data record/field replaceable unit (SDR/FRU) data, and to remotely manage a network. For information about using these programs, see “Using the baseboard management controller” on page 61.

- **Boot Menu program**

The Boot Menu program is part of the BIOS. Use it to override the startup sequence that is set in the Configuration/Setup Utility program and temporarily assign a device to be first in the startup sequence, see “Using the Boot Menu program” on page 73.

- **Broadcom Gigabit Ethernet Utility program**

The Broadcom Gigabit Ethernet Utility program is part of the BIOS. You can use it to configure the network as a startable device, and you can customize where the network startup option appears in your startup sequence. Enable the Broadcom Gigabit Ethernet Utility from the Configuration/Setup Utility program. For information, see “Enabling the Broadcom Gigabit Ethernet Utility program” on page 73.

- **Ethernet controller configuration**

For information about configuring the Ethernet controller, see “Configuring the Broadcom Gigabit Ethernet controller” on page 74.

- **Remote Supervisor Adapter II SlimLine configuration**

For information about setting up and cabling the Remote Supervisor Adapter II SlimLine, see “Setting up the Remote Supervisor Adapter II SlimLine” on page 74.

- **ServeRAID Manager**

ServeRAID Manager is available as a stand-alone program and as an IBM Director extension. Use the ServeRAID Manager to define and configure the disk-array subsystem *before* you install the operating system. For information about using this program, see “Using ServeRAID Manager” on page 77.

- **IBM Director**

IBM Director is a workgroup-hardware-management tool that you can use to centrally manage servers. If you plan to use IBM Director to manage the server, you must check for the latest applicable IBM Director updates and interim fixes.

For information about updating IBM Director, see “Updating IBM Director” on page 79. For more information about IBM Director, see the IBM Director documentation on the *IBM Director CD*.

Using the Configuration/Setup Utility program

Use the Configuration/Setup Utility program to perform the following tasks:

- View configuration information
- View and change assignments for devices and I/O ports
- Set the date and time
- Set and change passwords and Remote Control Security settings
- Set the startup characteristics of the server and the order of startup devices
- Set and change settings for advanced hardware features
- Set and change settings for the baseboard management controller (BMC)
- View and clear error logs

Starting the Configuration/Setup Utility program

To start the Configuration/Setup Utility program, complete the following steps:

1. Turn on the server.
2. When the prompt Press F1 for Configuration/Setup is displayed, press F1. If you have set both a power-on password and an administrator password, you must type the administrator password to access the full Configuration/Setup Utility menu. If you do not type the administrator password, a limited Configuration/Setup Utility menu is available.
3. Select settings to view or change.

Configuration/Setup Utility menu choices

The following choices are on the Configuration/Setup Utility main menu. Depending on the version of the BIOS, some menu choices might differ slightly from these descriptions.

- **System Summary**

Select this choice to view configuration information, including the type, speed, and cache sizes of the microprocessors and the amount of installed memory. When you make configuration changes through other choices in the Configuration/Setup Utility program, the changes are reflected in the system summary; you cannot change settings directly in the system summary.

This choice is on the full and limited Configuration/Setup Utility menu.

- **Processor Summary**

Select this choice to view the processor information, including the type, speed, and cache size of the microprocessor.

- **System Information**

Select this choice to view information about the server. When you make changes through other choices in the Configuration/Setup Utility program, some of those changes are reflected in the system information; you cannot change settings directly in the system information.

This choice is on the full Configuration/Setup Utility menu only.

- **Devices and I/O Ports**

Select this choice to view or change assignments for devices and input/output (I/O) ports.

Select this choice to enable or disable integrated Ethernet controllers and all standard ports (such as serial, USB, and parallel). **Enable** is the default setting for all controllers. If you disable a device, it cannot be configured, and the operating system will not be able to detect it (this is equivalent to disconnecting the device). If you disable the integrated Ethernet controller and no Ethernet adapter is installed, the server will have no Ethernet capability. If you disable the integrated USB controller, the server will have no USB capability; to maintain USB capability, make sure that **Enabled** is selected for the **USB Support** and **USB 2.0 Support** options.

Select this choice to enable and configure serial remote video and keyboard redirection, and to set other remote console values.

This choice is on the full Configuration/Setup Utility menu only.

- **Parallel Port Setup**

Select this choice to enable or disable the parallel port and to adjust the parallel port resources and features.

- **Remote Console Redirection**

Select this choice to enable and configure serial remote video and keyboard redirection.

- **System MAC Addresses**

Select this choice to view the MAC addresses of the server.

- **Advanced Chipset Control**

Select this choice to modify settings that control features of the core chip set on the system board and to configure memory features.

Attention: Do not make changes in the **Advanced Chipset Control** option unless you are directed to do so by an IBM authorized service representative.

- **Video**

Select this choice to view the video information.

- **Date and Time**

Select this choice to set the date and time in the server, in 24-hour format (*hour:minute:second*).

- **System Security**

Select this choice to set password settings. See “Passwords” on page 58 for more information about passwords. You can also enable the chassis-intrusion detector to alert you each time that the server cover is removed.

- **Administrator Password**

This choice is on the Configuration/Setup Utility menu only if an optional IBM Remote Supervisor Adapter II SlimLine Slimline is installed.

Select this choice to set or change an administrator password. An administrator password is intended to be used by a system administrator; it limits access to the full Configuration/Setup Utility menu. If an administrator password is set, the full Configuration/Setup Utility menu is available only if

you type the administrator password at the password prompt. For more information, see “Administrator password” on page 59.

- **Power-on Password**

Select this choice to set or change a power-on password. See “Power-on password” on page 58 for more information.

- **Start Options**

Select this choice to view or change the start options. Changes in the start options take effect when you restart the server.

You can set keyboard operating characteristics, such as whether the server starts with the keyboard number lock on or off. You can enable the server to run without a monitor, or keyboard.

This choice is on the full Configuration/Setup Utility menu only.

- **Startup Sequence Options**

The startup sequence specifies the order in which the server checks devices to find a boot record. The server starts from the first boot record that it finds. If the server has Wake on LAN hardware and software and the operating system supports Wake on LAN functions, you can specify a startup sequence for the Wake on LAN functions. You can also specify whether an integrated controller or a PCI adapter has boot precedence.

If you enable the boot fail count, the BIOS default settings will be restored after three consecutive failures to find a boot record.

- **Advanced Setup**

Select this choice to change settings for advanced hardware features.

Important: The server might malfunction if these optional devices are incorrectly configured. Follow the instructions on the screen carefully.

This choice is on the full Configuration/Setup Utility menu only.

- **CPU Options**

Select this choice to enable or disable Hyper-Threading, the pre-fetch queue, C1 enhanced mode, and no-execute mode memory protection.

The default setting for Hyper-Threading is **Enabled**.

- **PCI Bus Control**

Select this choice to view the system resources that are used by the installed PCI, PCI Express, or PCI-X devices.

- **IPMI**

Select this choice to view or clear the system event log, make changes to the serial/modem device commands and the POST watchdog settings, and view the LAN settings.

- **IPMI Specification Version**

This is a nonselectable menu item that displays the IPMI and BMC version.

- **BMC Hardware/Firmware Version**

This is a nonselectable menu item that displays the BMC firmware version.

- **Clear System Event Log**

Enable or disable the system event log clearing. If system event-log clearing is enabled, it will reset to disabled when the BMC system-event log is cleared. **Disabled** is the default setting.

- **Existing Event Log number**

This is a nonselectable menu item that displays the number of entries in the system-event log.

- **BIOS POST Watchdog**
Enable or disable the BMC POST watchdog. **Disabled** is the default setting.
- **POST Watchdog Timeout**
Set the BMC POST watchdog timeout value. **5 minutes** is the default setting.
- **System Event Log**
Select this choice to view the BMC system-event log, which contains all system error and warning messages that have been generated. Use the arrow keys to move among pages in the log. If an optional IBM Remote Supervisor Adapter II SlimLine is installed, the full text of the error messages is displayed; otherwise, the log contains only numeric error codes. Run the diagnostic program to get more information about error codes that occur. For instructions, see the diagnostic information in the *Problem Determination and Service Guide* on the IBM System Documentation CD. Select **Clear System Event Log** to clear the BMC system-event log.

Important: If the system-error LED on the front of the server is lit but there are no other error indications, clear the BMC system-event log. This log does not clear itself, and if it begins to fill up, the system-error LED will be lit. Also, after you complete a repair or correct an error, clear the BMC system-event log to turn off the system-error LED on the front of the server.
- **Serial /Modem Device Commands**
Select this choice to change the serial port sharing and access mode.
 - **Serial Port Sharing**
Enable or disable serial port sharing. **Enabled** is the default setting.
 - **Serial Port Access Mode**
Share, disable, preboot only, or always available. **Shared** is the default setting.
- **LAN Settings**
Select this choice to view the baseboard management controller network configuration information.
- **NMI Options**
Select this choice to enable or disable the NMI reboot. **Enabled** is the default setting.
- **Error Logs**
Select this choice to view or clear error logs.
 - **POST Error Log**
Select this choice to view the three most recent error codes and messages that the system generated during POST. For more information about error logs, see IPMI on page 56.
 - **System Event/Error Log**
Select this choice to view error codes and messages that the system generated during POST and all system status messages from the service processor. Select **Clear error logs** to clear the system event/error log. For more information on error logs, see IPMI on page 56.

Important: If the system-error LED on the front of the server is lit but there are no other error indications, clear the system event/error log. This log does not clear itself, and if it begins to fill up, the system-error LED will be lit. Also, after you complete a repair or correct an error, clear the system event/error log to turn off the system-error LED on the front of the server.
- **Save Settings**

Select this choice to save the changes that you have made in the settings.

- **Restore Settings**

Select this choice to cancel the changes that you have made in the settings and restore the previous settings.

- **Load Default Settings**

Select this choice to cancel the changes that you have made in the settings and restore the factory settings.

- **Exit Setup**

Select this choice to exit from the Configuration/Setup Utility program. If you have not saved the changes that you have made in the settings, you are asked whether you want to save the changes or exit without saving them.

Passwords

From the **System Security** choice, you can set, change, and delete a power-on password and an administrator password. The **System Security** choice is on the full Configuration/Setup menu only.

If you set only a power-on password, you must type the power-on password to complete the system startup and to have access to the full Configuration/Setup Utility menu.

An administrator password is intended to be used by a system administrator; it limits access to the full Configuration/Setup Utility menu. If you set only an administrator password, you do not have to type a password to complete the system startup, but you must type the administrator password to access the Configuration/Setup Utility menu.

If you set a power-on password for a user and an administrator password for a system administrator, you can type either password to complete the system startup. A system administrator who types the administrator password has access to the full Configuration/Setup Utility menu; the system administrator can give the user authority to set, change, and delete the power-on password. A user who types the power-on password has access to only the limited Configuration/Setup Utility menu; the user can set, change, and delete the power-on password, if the system administrator has given the user that authority.

Power-on password

If a power-on password is set, when you turn on the server, the system startup will not be completed until you type the power-on password. You can use any combination of up to seven characters (A - Z, a - z, and 0 - 9) for the password.

When a power-on password is set, you can enable the Unattended Start mode, in which the keyboard and mouse remain locked but the operating system can start. You can unlock the keyboard and mouse by typing the power-on password.

If you forget the power-on password, you can regain access to the server in any of the following ways:

- If an administrator password is set, type the administrator password at the password prompt. Start the Configuration/Setup Utility program and reset the power-on password.
- Remove the server battery and then reinstall it. For instructions for removing the battery, see the *Problem Determination and Service Guide* on the IBM System x3500 Documentation CD.

- Toggle switch 2 of SW4 on the system board to the on position to bypass the power-on password check.

Attention: Before you change any switch settings or move any jumpers, turn off the server; then, disconnect all power cords and external cables. Do not change settings or move jumpers on any system-board switch or jumper blocks that are not shown in this document.

The following illustration shows the locations of the power-on password override, boot recovery, and Wake on LAN bypass jumpers.

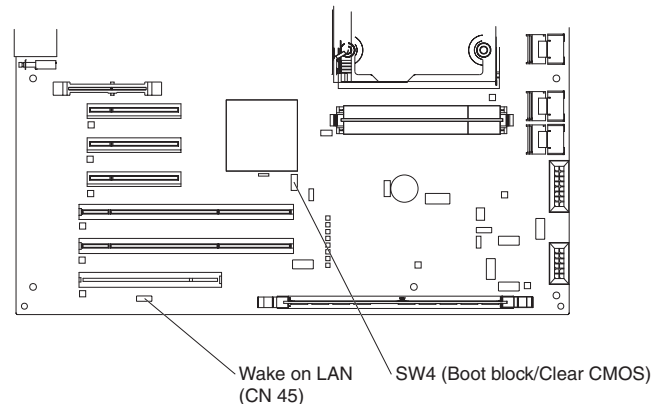

While the server is turned off, toggle the position of switch 2 of SW4 to the on position. You can then start the Configuration/Setup Utility program and reset the power-on password. After you reset the password, turn off the server again and move the switch back to the off position.

The power-on password override switch does not affect the administrator password.

Administrator password

If an administrator password is set, you must type the administrator password for access to the full Configuration/Setup Utility menu. You can use any combination of up to seven characters (A - Z, a - z, and 0 - 9) for the password. The **Administrator Password** choice is on the Configuration/Setup Utility menu only if an optional IBM Remote Supervisor Adapter II SlimLine is installed.

Attention: If you forget the administrator password, you must replace the system board.

Using the ServerGuide Setup and Installation CD

The *ServerGuide Setup and Installation CD* contains a setup and installation program that is designed for your server. The ServerGuide program detects the server model and optional hardware devices that are installed and uses that information during setup to configure the hardware. The ServerGuide program simplifies operating-system installations by providing updated device drivers and, in some cases, installing them automatically.

If a later version of the ServerGuide program is available, you can download a free image of the *ServerGuide Setup and Installation CD* or purchase the CD from the ServerGuide fulfillment Web site at <http://www.ibm.com/systems/management/serverguide/sub.html>. To download the free image, click **IBM Service and Support Site**.

Note: Changes are made periodically to the IBM Web site. The actual procedure might vary slightly from what is described in this document.

The ServerGuide program has the following features:

- An easy-to-use interface
- Diskette-free setup, and configuration programs that are based on detected hardware
- ServeRAID Manager program, which configures your ServeRAID adapter or integrated SAS/SATA controller with RAID capabilities
- Device drivers that are provided for the server model and detected hardware
- File-system type that is selectable during setup

ServerGuide features

Features and functions can vary slightly with different versions of the ServerGuide program. To learn more about the version that you have, start the *ServerGuide Setup and Installation* CD and view the online overview. Not all features are supported on all server models.

The ServerGuide program requires a supported IBM server with an enabled startable (bootable) CD drive. In addition to the *ServerGuide Setup and Installation* CD, you must have the operating-system CD to install the operating system.

The ServerGuide program performs the following tasks:

- Sets system date and time
- Detects an installed SAS RAID adapter or controller and runs the SAS RAID configuration program
- Checks the microcode (firmware) levels of a ServeRAID adapter and determines whether a later level is available from the CD
- Detects installed optional hardware devices and provides updated device drivers for most adapters and devices
- Provides diskette-free installation for supported Windows operating systems
- Includes an online readme file with links to tips for your hardware and operating-system installation

Setup and configuration overview

When you use the *ServerGuide Setup and Installation* CD, you do not need setup diskettes. You can use the CD to configure any supported IBM server model. The setup program provides a list of tasks that are required to set up the server model. On a server with a ServeRAID SAS controller or integrated SAS/SATA controller with RAID capabilities, you can run ServeRAID Manager to create logical drives.

Note: Features and functions can vary slightly with different versions of the ServerGuide program.

When you start the *ServerGuide Setup and Installation* CD, the program prompts you to complete the following tasks:

- Select your language.
- Select your keyboard layout and country.
- View the overview to learn about ServerGuide features.
- View the readme file to review installation tips for your operating system and adapter.
- Start the operating-system installation. You will need your operating-system CD.

Typical operating system installation

The ServerGuide program can reduce the time it takes to install an operating system. It provides the device drivers that are required for your hardware and for the operating system that you are installing. This section describes a typical ServerGuide operating-system installation.

Note: Features and functions can vary slightly with different versions of the ServerGuide program.

1. After you have completed the setup process, the operating-system installation program starts. (You will need your operating-system CD to complete the installation.)
2. The ServerGuide program stores information about the server model, service processor, hard disk drive controllers, and network adapters. Then, the program checks the CD for newer device drivers. This information is stored and then passed to the operating-system installation program.
3. The ServerGuide program prompts you to insert your operating-system CD and restart the server. At this point, the installation program for the operating system takes control to complete the installation.

Installing your operating system without ServerGuide

If you have already configured the server hardware and you are not using the ServerGuide program to install your operating system, complete the following steps to download the latest operating-system installation instructions from the IBM Web site.

Note: Changes are made periodically to the IBM Web site. The actual procedure might vary slightly from what is described in this document.

1. Go to <http://www.ibm.com/systems/support/>.
2. Under **Product support**, click **System x**.
3. From the menu on the left side of the page, click **System x support search**.
4. From the **Task** menu, select **Install**.
5. From the **Product family** menu, select **System x3500**.
6. From the **Operating system** menu, select your operating system, and then click **Search** to display the available installation documents.

Using the baseboard management controller

The baseboard management controller provides environmental monitoring for the server. If environmental conditions exceed thresholds or if system components fail, the baseboard management controller lights LEDs to help you diagnose the problem and also records the error in the system event/error log.

The baseboard management controller also provides the following remote server management capabilities through the OSA SMBridge management utility program:

- **Command-line interface (IPMI Shell)**

The command-line interface provides direct access to server management functions through the IPMI protocol. Use the command-line interface to issue commands to control the server power, view system information, and identify the server. You can also save one or more commands as a text file and run the file as a script.

- **Serial over LAN**

Establish a Serial over LAN (SOL) connection to manage servers from a remote location. You can remotely view and change the BIOS settings, restart the server, identify the server, and perform other management functions. Any standard Telnet client application can access the SOL connection.

Enabling and configuring SOL using the OSA SMBridge management utility program

To enable and configure the server for SOL by using the OSA SMBridge management utility program, you must update and configure the BIOS; update and configure the baseboard management controller (BMC) firmware; update and configure the Ethernet controller firmware; and enable the operating system for an SOL connection.

BIOS update and configuration

Complete the following steps to update and configure the BIOS code to enable SOL:

1. Update the BIOS code:
 - a. Download the latest version of the BIOS code from <http://www.ibm.com/systems/support/>.
 - b. Update the BIOS code, following the instructions that come with the update file that you downloaded.
2. Update the BMC firmware:
 - a. Download the latest version of the BMC firmware from <http://www.ibm.com/systems/support/>.
 - b. Update the BMC firmware, following the instructions that come with the update file that you downloaded.
3. Configure the BIOS settings:
 - a. Restart the server and press F1 when are prompted to start the Configuration/Setup Utility program.
 - b. Select **Devices and I/O Ports**; then, make sure that the values are set as follows:
 - **Serial Port A**: Auto-configure
 - **Serial Port B**: Auto-configure
 - c. Select **Remote Console Redirection**; then, make sure that the values are set as follows:
 - **Remote Console COM Port**: COM 2
 - **Remote Console Baud Rate**: 19200 or higher
 - **Remote Console Connection Type**: VT100
 - **Remote Console Connect**: Direct
 - **Remote Console Flow Control**: Hardware
 - **Remote Console Active After Boot**: Enabled
 - d. Press Esc twice to exit the **Remote Console Redirection** and **Devices and I/O Ports** sections of the Configuration/Setup Utility program.
 - e. Select **Advanced Setup**; then, select **Baseboard Management Controller (BMC) Settings**.
 - f. Set **BMC Serial Port Access Mode** to **Dedicated**.
 - g. Press Esc twice to exit the **Baseboard Management Controller (BMC) Settings** and **Advanced Setup** sections of the Configuration/Setup Utility program.

- h. Select **Save Settings**; then, press Enter.
- i. Press Enter to confirm.
- j. Select **Exit Setup**; then, press Enter.
- k. Make sure that **Yes, exit the Setup Utility** is selected; then, press Enter.

Linux configuration

For SOL operation on the server, you must configure the Linux® operating system to expose the Linux initialization (booting) process. This enables users to log in to the Linux console through an SOL session and directs Linux output to the serial console. See the documentation for your specific Linux operating-system type for information and instructions.

Use one of the following procedures to enable SOL sessions for your Linux operating system. You must be logged in as a root user to perform these procedures.

Red Hat Enterprise Linux ES 2.1 configuration:

Note: This procedure is based on a default installation of Red Hat Enterprise Linux ES 2.1. The file names, structures, and commands might be different for other versions of Red Hat Linux.

Complete the following steps to configure the general Linux parameters for SOL operation when using the Red Hat Enterprise Linux ES 2.1 operating system.

Note: Hardware flow control prevents character loss during communication over a serial connection. You must enable it when using a Linux operating system.

1. Add the following line to the end of the # Run gettys in standard runlevels section of the /etc/inittab file. This enables hardware flow control and enables users to log in through the SOL console.
7:2345:respawn:/sbin/agetty -h ttyS0 19200 vt102
2. Add the following line at the bottom of the /etc/securetty file to enable a user to log in as the root user through the SOL console:
ttyS0

LILO configuration: If you are using LILO, complete the following steps:

1. Complete the following steps to modify the /etc/lilo.conf file:
 - a. Add the following text to the end of the first default=linux line
-Monitor
 - b. Comment out the map=/boot/map line by adding a # at the beginning of this line.
 - c. Comment out the message=/boot/message line by adding a # at the beginning of this line.
 - d. Add the following line before the first image= line:
This will allow you to only Monitor the OS boot via SOL
 - e. Add the following text to the end of the first label=linux line:
-Monitor
 - f. Add the following line to the first image= section. This enables SOL.
append="console=ttyS0,19200n8 console=tty1"
 - g. Add the following lines between the two image= sections:
This will allow you to Interact with the OS boot via SOL
image=/boot/vmlinuz-2.4.9-e.12smp

```
label=linux-Interact
initrd=/boot/initrd-2.4.9-e.12smp.img
read-only
root=/dev/hda6
append="console=tty1 console=ttyS0,19200n8 "
```

The following examples show the original content of the `/etc/lilo.conf` file and the content of this file after modification.

Original <code>/etc/lilo.conf</code> contents
<pre>prompt timeout=50 default=linux boot=/dev/hda map=/boot/map install=/boot/boot.b message=/boot/message linear image=/boot/vmlinuz-2.4.9-e.12smp label=linux initrd=/boot/initrd-2.4.9-e.12smp.img read-only root=/dev/hda6 image=/boot/vmlinuz-2.4.9-e.12 label=linux-up initrd=/boot/initrd-2.4.9-e.12.img read-only root=/dev/hda6</pre>

Modified /etc/lilo.conf contents

```
prompt
timeout=50
default=linux-Monitor
boot=/dev/hda
#map=/boot/map
install=/boot/boot.b
#message=/boot/message
linear
# This will allow you to only Monitor the OS boot via SOL
image=/boot/vmlinuz-2.4.9-e.12smp
    label=linux-Monitor
    initrd=/boot/initrd-2.4.9-e.12smp.img
    read-only
    root=/dev/hda6
    append="console=ttyS0,19200n8 console=tty1"
# This will allow you to Interact with the OS boot via SOL
image=/boot/vmlinuz-2.4.9-e.12smp
    label=linux-Interact
    initrd=/boot/initrd-2.4.9-e.12smp.img
    read-only
    root=/dev/hda6
    append="console=tty1 console=ttyS0,19200n8 "
image=/boot/vmlinuz-2.4.9-e.12
    label=linux-up
    initrd=/boot/initrd-2.4.9-e.12.img
    read-only
    root=/dev/hda6
```

2. Run the **lilo** command to store and activate the LILO configuration.

When the Linux operating system starts, a LILO boot: prompt is displayed instead of the graphical user interface. Press Tab at this prompt to install all of the boot options that are listed. To load the operating system in interactive mode, type linux-Interact and then press Enter.

GRUB configuration: If you are using GRUB, complete the following steps to modify the /boot/grub/grub.conf file:

1. Comment out the splashimage= line by adding a # at the beginning of this line.
2. Add the following line before the first title= line:
This will allow you to only Monitor the OS boot via SOL
3. Append the following text to the first title= line:
SOL Monitor
4. Append the following text to the kernel/ line of the first title= section:
console=ttyS0,19200 console=tty1
5. Add the following five lines between the two title= sections:
This will allow you to Interact with the OS boot via SOL
title Red Hat Linux (2.4.9-e.12smp) SOL Interactive
root (hd0,0)

```
kernel /vmlinuz-2.4.9-e.12smp ro root=/dev/hda6 console=tty1
console=ttyS0,19200
initrd /initrd-2.4.9-e.12smp.img
```

Note: The entry that begins with `kernel /vmlinuz` is shown with a line break after `console=tty1`. In your file, the entire entry must all be on one line.

The following examples show the original content of the `/boot/grub/grub.conf` file and the content of this file after modification.

Original `/boot/grub/grub.conf` contents

```
#grub.conf generated by anaconda
#
# Note that you do not have to rerun grub after making changes to this file
# NOTICE: You have a /boot partition. This means that
#         all kernel and initrd paths are relative to /boot/, eg.
#         root (hd0,0)
#         kernel /vmlinuz-version ro root=/dev/hda6
#         initrd /initrd-version.img
#boot=/dev/hda
default=0
timeout=10
splashimage=(hd0,0)/grub/splash.xpm.gz
title Red Hat Enterprise Linux ES (2.4.9-e.12smp)
    root (hd0,0)
    kernel /vmlinuz-2.4.9-e.12smp ro root=/dev/hda6
    initrd /initrd-2.4.9-e.12smp.img
title Red Hat Enterprise Linux ES-up (2.4.9-e.12)
    root (hd0,0)
    kernel /vmlinuz-2.4.9-e.12 ro root=/dev/hda6
    initrd /initrd-2.4.9-e.12.img
```

Modified /boot/grub/grub.conf contents

```
#grub.conf generated by anaconda
#
# Note that you do not have to rerun grub after making changes to this file
# NOTICE: You have a /boot partition. This means that
#         all kernel and initrd paths are relative to /boot/, eg.
#         root (hd0,0)
#         kernel /vmlinuz-version ro root=/dev/hda6
#         initrd /initrd-version.img
#boot=/dev/hda
default=0
timeout=10
# splashimage=(hd0,0)/grub/splash.xpm.gz
# This will allow you to only Monitor the OS boot via SOL
title Red Hat Enterprise Linux ES (2.4.9-e.12smp) SOL Monitor
    root (hd0,0)
    kernel /vmlinuz-2.4.9-e.12smp ro root=/dev/hda6 console=ttyS0,19200 console=tty1
    initrd /initrd-2.4.9-e.12smp.img
# This will allow you to Interact with the OS boot via SOL
title Red Hat Linux (2.4.9-e.12smp) SOL Interactive
    root (hd0,0)
    kernel /vmlinuz-2.4.9-e.12smp ro root=/dev/hda6 console=tty1 console=ttyS0,19200
    initrd /initrd-2.4.9-e.12smp.img
title Red Hat Enterprise Linux ES-up (2.4.9-e.12)
    root (hd0,0)
    kernel /vmlinuz-2.4.9-e.12 ro root=/dev/hda6
    initrd /initrd-2.4.9-e.12.img
```

You must restart the Linux operating system after you complete these procedures for the changes to take effect and to enable SOL.

SUSE SLES 8.0 configuration:

Note: This procedure is based on a default installation of SUSE Linux Enterprise Server (SLES) 8.0. The file names, structures, and commands might be different for other versions of SUSE Linux.

Complete the following steps to configure the general Linux parameters for SOL operation when using the SLES 8.0 operating system.

Note: Hardware flow control prevents character loss during communication over a serial connection. You must enable it when using a Linux operating system.

1. Add the following line to the end of the # getty-programs for the normal runlevels section of the /etc/inittab file. This enables hardware flow control and enables users to log in through the SOL console.
7:2345:respawn:/sbin/agetty -h ttyS0 19200 vt102
2. Add the following line after the tty6 line at the bottom of the /etc/securetty file to enable a user to log in as the root user through the SOL console:
ttyS0
3. Complete the following steps to modify the /boot/grub/menu.lst file:

- a. Comment out the gfxmenu line by adding a # in front of the word gfxmenu.
- b. Add the following line before the first title line:
This will allow you to only Monitor the OS boot via SOL
- c. Append the following text to the first title line:
SOL Monitor
- d. Append the following text to the kernel line of the first title section:
console=ttyS0,19200 console=tty1
- e. Add the following four lines between the first two title sections:
This will allow you to Interact with the OS boot via SOL
title linux SOL Interactive
kernel (hd0,1)/boot/vmlinuz root=/dev/hda2 acpi=oldboot vga=791
console=tty1 console=ttyS0,19200
initrd (hd0,1)/boot/initrd

The following examples show the original content of the /boot/grub/menu.lst file and the content of this file after modification.

Original /boot/grub/menu.lst contents	Notes
<pre>gfxmanu (hd0,1)/boot/message color white/blue black/light-gray default 0 timeout 8 title linux kernel (hd0,1)/boot/vmlinuz root=/dev/hda2 acpi=oldboot vga=791 initrd (hd0,1)/boot/initrd title floppy root chainloader +1 title failsafe kernel (hd0,1)/boot/vmlinuz.shipped root=/dev/hda2 ide=nodma apm=off vga=normal nosmp disableapic maxcpus=0 3 initrd (hd0,1)/boot/initrd.shipped</pre>	<p>1</p> <p>1</p>
<p>Note 1: The kernel line is shown with a line break. In your file, the entire entry must all be on one line.</p>	

Modified /boot/grub/menu.lst contents	Notes
<pre>#gfxmanu (hd0,1)/boot/message color white/blue black/light-gray default 0 timeout 8 # This will allow you to only Monitor the OS boot via SOL title linux SOL Monitor kernel (hd0,1)/boot/vmlinuz root=/dev/hda2 acpi=oldboot vga=791 console=ttyS1,19200 console=tty1 initrd (hd0,1)/boot/initrd # This will allow you to Interact with the OS boot via SOL title linux SOL Interactive kernel (hd0,1)/boot/vmlinuz root=/dev/hda2 acpi=oldboot vga=791 console=tty1 console=ttyS0,19200 initrd (hd0,1)/boot/initrd title floppy</pre>	<p>1</p>

Modified /boot/grub/menu.lst contents	Notes
<pre> root chainloader +1 title failsafe kernel (hd0,1)/boot/vmlinuz.shipped root=/dev/hda2 ide=nodma apm=off vga=normal nosmp disableapic maxcpus=0 3 initrd (hd0,1)/boot/initrd.shipped </pre>	1
<p>Note 1: The kernel line is shown with a line break. In your file, the entire entry must all be on one line.</p>	

You must restart the Linux operating system after you complete these procedures for the changes to take effect and to enable SOL.

Microsoft Windows 2003 Standard Edition configuration

Note: This procedure is based on a default installation of the Microsoft Windows 2003 operating system.

Complete the following steps to configure the Windows 2003 operating system for SOL operation. You must be logged in as a user with administrator access to perform this procedure.

1. Complete the following steps to determine which boot entry ID to modify:
 - a. Type `bootcfg` at a Windows command prompt; then, press Enter to display the current boot options for your server.
 - b. In the Boot Entries section, locate the boot entry ID for the section with an OS friendly name of Windows Server 2003, Standard. Write down the boot entry ID for use in the next step.
2. To enable the Microsoft Windows Emergency Management System (EMS), at a Windows command prompt, type

```
bootcfg /EMS ON /PORT COM1 /BAUD 19200 /ID boot_id
```

where *boot_id* is the boot entry ID from step 1b; then, press Enter.

3. Complete the following steps to verify that the EMS console is redirected to the COM2 serial port:
 - a. Type `bootcfg` at a Windows command prompt; then, press Enter to display the current boot options for your server.
 - b. Verify the following changes to the bootcfg settings:
 - In the Boot Loader Settings section, make sure that `redirect` is set to COM2 and that `redirectbaudrate` is set to 19200.
 - In the Boot Entries section, make sure that the OS Load Options: line has `/redirect` appended to the end of it.

The following examples show the original bootcfg program output and the output after modification.

Original bootcfg program output

```
Boot Loader Settings
-----
timeout: 30
default: multi(0)disk(0)rdisk(0)partition(1)\WINDOWS
Boot Entries
-----
Boot entry ID: 1
OS Friendly Name: Windows Server 2003, Standard
Path: multi(0)disk(0)rdisk(0)partition(1)\WINDOWS
OS Load Options: /fastdetect
```

Modified bootcfg program output

```
Boot Loader Settings
-----
timeout: 30
default: multi(0)disk(0)rdisk(0)partition(1)\WINDOWS
redirect: COM1
redirectbaudrate: 19200
Boot Entries
-----
Boot entry ID: 1
OS Friendly Name: Windows Server 2003, Standard
Path: multi(0)disk(0)rdisk(0)partition(1)\WINDOWS
OS Load Options: /fastdetect /redirect
```

You must restart the Windows 2003 operating system after you complete this procedure for the changes to take effect and to enable SOL.

Installing the OSA SMBridge management utility program

Complete the following steps to install the OSA SMBridge management utility program on a server running a Windows operating system:

1. Go to <http://www.ibm.com/systems/support/>, download the utility program, and create the OSA BMC Management Utility CD.
2. Insert the OSA BMC Management Utility CD into the drive. The InstallShield wizard starts, and a window similar to that shown in the following illustration opens.

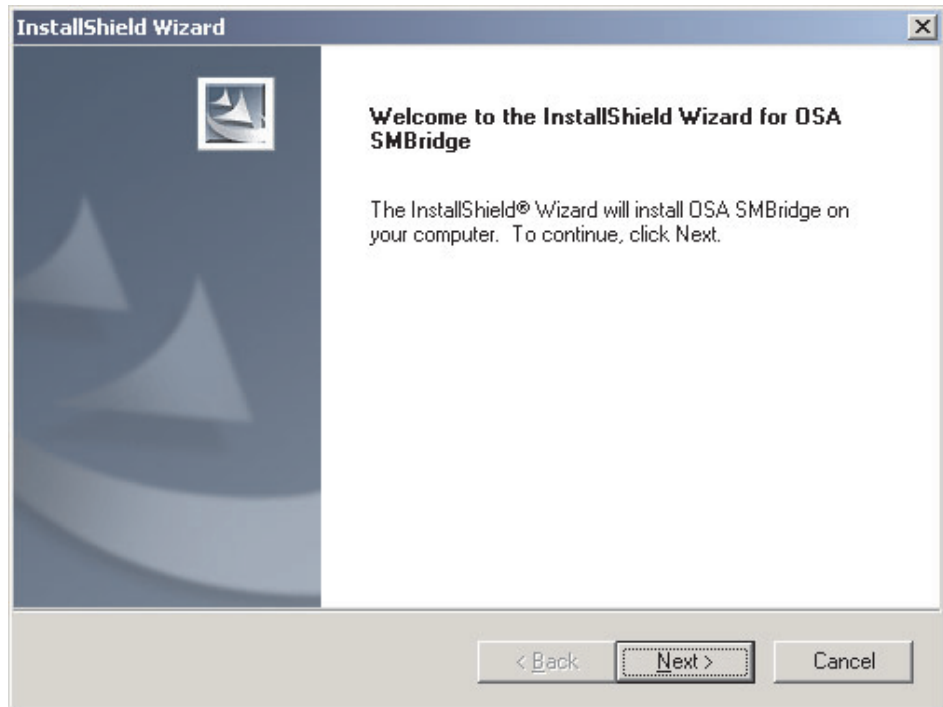

3. Follow the prompts to complete the installation.

The installation program prompts you for a TCP/IP port number and an IP address. Specify an IP address, if you want to limit the connection requests that will be accepted by the utility program. To accept connections from any server, type `INADDR_ANY` as the IP address. Also specify the port number that the utility program will use. These values will be recorded in the `smbridge.cfg` file for the automatic startup of the utility program.

Complete the following steps to install the OSA SMBridge management utility program on a server running a Linux operating system. You must be logged in as a root user to perform these procedures.

1. Go to <http://www.ibm.com/systems/support/>, download the utility program, and create the OSA BMC Management Utility CD.
2. Insert the OSA BMC Management Utility CD into the drive.
3. Type `mount/mnt/cdrom`.
4. Locate the directory where the installation RPM package is located and type `cd/mnt/cdrom`.
5. Type the following command to run the RPM package and start the installation:
`rpm -ivh smbridge-2.0-XX.rpm`
6. Follow the prompts to complete the installation. When the installation is complete, the utility copies files to the following directories:
 - `/etc/init.d/SMBridge`
 - `/etc/smbridge.cfg`
 - `/usr/sbin/smbrided`
 - `/var/log/smbridge/License.txt`
 - `/var/log/smbridge/Readme.txt`

The utility starts automatically when the server is started. You can also locate the `/ect/init.d` directory to start the utility and use the following commands to manage the utility:

```
smbridge status
smbridge start
smbridge stop
smbridge restart
```

Using the baseboard management controller utility programs

Use the baseboard management controller utility programs to configure the baseboard management controller, download firmware updates and SDR/FRU updates, and remotely manage a network.

Using the baseboard management controller configuration utility program

Use the baseboard management controller configuration utility program to view or change the baseboard management controller configuration settings. You can also use the utility program to save the configuration to a file for use on multiple servers.

Complete the following steps to start the baseboard management controller configuration utility program:

1. Insert the configuration utility diskette into the diskette drive and restart the server.
2. From a command-line prompt, type `bmc_cfg` and press Enter.
3. Follow the instructions on the screen.

Using the baseboard management controller firmware update utility program

Use the baseboard management controller firmware update utility disk to update the baseboard management controller firmware and SDR/FRU data. The firmware update utility updates the baseboard management controller firmware and SDR/FRU data only and does not affect any device drivers.

Note: To ensure proper server operation, be sure to update the server baseboard management controller firmware before you update the BIOS code.

To update the firmware, if the Linux or Windows operating-system update package is available from the World Wide Web and you have obtained the applicable update package, follow the instructions that come with the update package.

Using the OSA SMBridge management utility program

Use the OSA SMBridge management utility program to remotely manage and configure a network. The utility program provides the following remote management capabilities:

- **CLI (command-line interface) mode**

Use CLI mode to remotely perform power-management and system identification control functions over a LAN or serial port interface from a command-line interface. Use CLI mode also to remotely view the system event/error log.

Use the following commands in CLI mode:

- **identify**

Control the system-locator LED on the front of the server.

- **power**

Turn the server on and off remotely.

- **sel**

Perform operations with the BMC system event log.

- **sysinfo**
Display general system information that is related to the server and the baseboard management controller.
- **Serial over LAN**
Use the Serial over LAN capability to remotely perform control and management functions over a Serial over LAN (SOL) network. You can also use SOL to remotely view and change the server BIOS settings.
At a command prompt, type `Telnet localhost 623` to access the SOL network. Type `help` at the `smbridge>` prompt for more information.
Use the following commands in an SOL session:
 - **connect**
Connect to the LAN. Type `connect -ip ip_address -u username -p password`.
 - **identify**
Control the system-locator LED on the front of the server.
 - **power**
Turn the server on and off remotely.
 - **reboot**
Force the server to restart.
 - **sel get**
Display the system event/error log.
 - **sol**
Configure the SOL function.
 - **sysinfo**
Display system information that is related to the server and the globally unique identifier (GUID).

Using the Boot Menu program

The Boot Menu program is a built-in, menu-driven configuration program that you can use to temporarily redefine the first startup device without changing settings in the Configuration/Setup Utility program.

To use the Boot Menu program, complete the following steps:

1. Turn off the server.
2. Restart the server.
3. Press F12.
4. Select the startup device.

The next time that the server is started, it returns to the startup sequence that is set in the Configuration/Setup Utility program.

Enabling the Broadcom Gigabit Ethernet Utility program

The Broadcom Gigabit Ethernet Utility is part of the BIOS. You can use it to configure the network as a startable device, and you can customize where the network startup option appears in the startup sequence.

To enable the Broadcom Gigabit Ethernet Utility program, complete the following steps:

1. From the Configuration/Setup Utility main menu, select **Devices and I/O Ports** and press Enter.
2. Select **Planar Ethernet** and use the Right Arrow (→) key to set it to **Enabled**.
3. Select **Save Settings** and press Enter.

Configuring the Broadcom Gigabit Ethernet controller

The Ethernet controller is integrated on the system board. It provides an interface for connecting to a 10 Mbps, 100 Mbps, or 1 Gbps network and provides full-duplex (FDX) capability, which enables simultaneous transmission and reception of data on the network. If the Ethernet port in the server supports auto-negotiation, the controller detects the data-transfer rate (10BASE-T, 100BASE-TX, or 1000BASE-T) and duplex mode (full-duplex or half-duplex) of the network and automatically operates at that rate and mode.

You do not have to set any jumpers or configure the controller. However, you must install a device driver to enable the operating system to address the controller. To find updated information about configuring the controller, complete the following steps.

Note: Changes are made periodically to the IBM Web site. The actual procedure might vary slightly from what is described in this document.

1. Go to <http://www.ibm.com/systems/support/>.
2. Under **Product support**, click **System x**.
3. Under **Popular links**, click **Publications lookup**.
4. From the **Product family** menu, select **System x3500** and click **Continue**.

Setting up the Remote Supervisor Adapter II SlimLine

You use the optional Remote Supervisor Adapter II SlimLine to obtain enhanced system management capabilities, above those of the embedded BMC. The Remote Supervisor Adapter II SlimLine has a dedicated Ethernet connection at the rear of the server.

This section describes how to set up, cable, and configure the Remote Supervisor Adapter II SlimLine so that you can manage the server remotely.

In addition to the information in this section, see the *IBM Remote Supervisor Adapter II SlimLine User's Guide* for information about how to configure and use the Remote Supervisor Adapter II SlimLine to manage the server remotely through the Web-based interface or the text-based interface.

Note: The Web-based interface and text-based interface do not support double-byte character set (DBCS) languages.

Requirements

Make sure that the following Remote Supervisor Adapter II SlimLine requirements are met:

- The Web interface Remote Disk function requires the client system to be running Microsoft Windows 2000 or later. The Web interface Remote Control features require the Java™ 1.4 Plug-in or later. The following Web browsers are supported:
 - Microsoft Internet Explorer version 5.5 or later with the latest Service Pack
 - Netscape Navigator version 7.0 or later

- Mozilla version 1.3 or later
- If you plan to configure Simple Network Management Protocol (SNMP) trap alerts on the Remote Supervisor Adapter II SlimLine, install and compile the management information base (MIB) on your SNMP manager.
- You will need an Internet connection to the client system to download software and firmware from the IBM Support Web site during the installation process. The Remote Supervisor Adapter II SlimLine firmware and the SNMP MIB are available on the *ServerGuide Setup and Installation* CD; the latest versions are available at <http://www.ibm.com/systems/management/serverguide/sub.html>.

Cabling the Remote Supervisor Adapter II SlimLine

You can manage the server remotely through the Remote Supervisor Adapter II SlimLine by using the dedicated system-management Ethernet connector on the rear of the server.

For additional information about network configuration, go to the *Remote Supervisor Adapter II SlimLine Installation Guide*.

Complete the following steps to cable the Remote Supervisor Adapter II SlimLine:

1. Connect one end of a Category 3 or Category 5 Ethernet cable to the dedicated systems-management Ethernet connector. See “Rear view” on page 10 for the location of the systems-management Ethernet connector.
2. Connect the other end of the cable to the network.

Installing the Remote Supervisor Adapter II SlimLine firmware

The software and firmware files that you need are contained in one system service package installation kit. The kit contains the following files:

- Software and firmware installation instructions
- BIOS code update with support for the Remote Supervisor Adapter II SlimLine
- Diagnostics code update
- Remote Supervisor Adapter II SlimLine device drivers
- Remote Supervisor Adapter II SlimLine firmware update
- Integrated service processor firmware update
- Video device driver
- Firmware-update utility program

Complete the following steps to download and install the software and firmware.

Note: Changes are made periodically to the IBM Web site. The actual procedure might vary slightly from what is described in this document.

1. Go to <http://www.ibm.com/support/>.
2. In the left navigation pane, click **Downloads and drivers**.
3. In the **Search** field, type **Remote Supervisor Adapter II SlimLine firmware** and click **Search**.
4. Select the system service package for the operating system that is running on the server in which the Remote Supervisor Adapter II SlimLine is installed.
5. Click the file link to download the system service package to *d:\ibmssp*, where *d* is the hard disk drive letter. (Create the directory if necessary.)
6. Extract the files into *d:\ibmssp*. See the *readme.txt* file, which is included with the extracted files, for a list of the files in the package.

7. Follow the instructions in *Remote Supervisor Adapter II SlimLine Installation Instructions*, which is in Portable Document Format (PDF) in *d:\ibmssp*, to install the software and firmware.
8. Restart the server after the software and firmware are installed.

Completing the setup

See the *IBM Remote Supervisor Adapter II SlimLine User's Guide* on the IBM *Documentation* CD for instructions for completing the configuration, including the following procedures:

- Configuring the Ethernet ports
- Defining login IDs and passwords
- Selecting the events that will receive alert notifications
- Monitoring remote server status using the Remote Supervisor Adapter II SlimLine Web-based interface
- Controlling the server remotely
- Attaching a remote diskette drive, CD drive, or disk image to the server

After you configure the adapter, use the Web-based interface to create a backup copy of the configuration so that you can restore the configuration, if you have to replace the adapter. For more information, see the *Remote Supervisor Adapter II SlimLine User's Guide*.

Using the Adaptec RAID Configuration Utility program

Use the Adaptec RAID Configuration Utility programs to perform the following tasks:

- Configure a redundant array of independent disks (RAID) array
- View or change the RAID configuration and associated devices

When you are using the Adaptec RAID Configuration Utility programs to configure and manage arrays, consider the following information:

- Hard disk drive capacities affect how you create arrays. Drives in an array can have different capacities, but the RAID controller treats them as if they all have the capacity of the smallest hard disk drive.
- To help ensure signal quality, do not mix drives with different speeds and data rates.
- To update the firmware and BIOS code for an optional ServeRAID SAS controller, you must use the IBM *ServeRAID Support* CD that comes with the ServeRAID option.

Starting the Adaptec RAID Configuration Utility program

To start the Adaptec RAID Configuration Utility program, complete the following steps:

1. Turn on the server.
2. When the prompt <<< Press <CTRL><A> for Adaptec RAID Configuration Utility! >>> is displayed, press Ctrl+A.
3. To select a choice from the menu, use the arrow keys to highlight it and press Enter.

Adaptec RAID Configuration Utility menu choices

The following choices are on the Adaptec RAID Configuration Utility menu:

- **Array Configuration Utility**
Select this choice to create, manage, or delete arrays, or to initialize drives.
- **SerialSelect Utility**
Select this choice to configure the controller interface definitions or to configure the physical transfer and SAS address of the selected drive.
- **Disk Utilities**
Select this choice to format a disk or verify the disk media. Select a device from the list and read the instructions on the screen carefully before you make a selection.

Creating a RAID array

To create a RAID array, complete the following steps:

1. Start the Adaptec RAID Configuration Utility program.
2. Select **Array Configuration Utility**.
3. From the Main menu, select **Create Array**.

Note: Hard disk drives in an array can have different capacities, but the RAID controller treats them as if they all have the capacity of the smallest hard disk drive.

4. From the list of available drives, select the drives that you want to include in the array and press Enter.
5. From the list of available RAID levels, select the one that you want to use.
6. Follow the instructions on the screen to complete the configuration; then, select **Done** to exit.
7. Restart the server.

Viewing the array configuration

To view information about the RAID array, complete the following steps:

1. Start the Adaptec RAID Configuration Utility program.
2. Select **Array Configuration Utility**.
3. From the Main menu, select **Manage Arrays**.
4. Select an array and press Enter.
5. To exit from the program, press Esc.

Using ServeRAID Manager

Use ServeRAID Manager, which is on the *IBM ServeRAID Support CD*, to:

- Configure a redundant array of independent disks (RAID) array
- Restore a SAS hard disk drive to the factory-default settings, erasing all data from the disk
- View your RAID configuration and associated devices
- Monitor the operation of your RAID controller

To perform some tasks, you can run ServeRAID Manager as an installed program. However, to configure the SAS and RAID controllers and perform an initial RAID configuration on the server, you must run ServeRAID Manager in Startable CD mode, as described in the instructions in this section. If you install a different type of

RAID adapter in the server, use the configuration method that is described in the instructions that come with that adapter to view or change SAS settings for attached devices.

See the ServeRAID documentation on the *IBM ServeRAID Support CD* for additional information about RAID technology and instructions for using ServeRAID Manager to configure your SAS and RAID controllers. Additional information about ServeRAID Manager is also available from the **Help** menu. For information about a specific object in the ServeRAID Manager tree, select the object and click **Actions→ Hints and tips**.

Configuring the controller

By running ServeRAID Manager in Startable CD mode, you can configure the controller before you install your operating system. The information in this section assumes that you are running ServeRAID Manager in Startable CD mode.

To run ServeRAID Manager in Startable CD mode, turn on the server; then, insert the CD into the DVD-ROM drive. If ServeRAID Manager detects an unconfigured controller and ready drives, the Configuration wizard starts.

In the Configuration wizard, you can select express configuration or custom configuration. Express configuration automatically configures the controller by grouping the first two physical drives in the ServeRAID Manager tree into an array and creating a RAID level-1 logical drive. If you select custom configuration, you can select the two physical drives that you want to group into an array and create a hot-spare drive.

Using express configuration

Complete the following steps to use express configuration:

1. In the ServeRAID Manager tree, click the controller.
2. Click **Express configuration**.
3. Click **Next**. The “Configuration summary” window opens.
4. Review the information in the “Configuration summary” window. To change the configuration, click **Modify arrays**.
5. Click **Apply**; then, click **Yes** when asked if you want to apply the new configuration. The configuration is saved in the controller and in the physical drives.
6. Exit from ServeRAID Manager and remove the CD from the DVD-ROM drive.
7. Restart the server.

Using custom configuration

Complete the following steps to use custom configuration:

1. In the ServeRAID Manager tree, click the controller.
2. Click **Custom configuration**.
3. Click **Next**. The “Create arrays” window opens.
4. From the list of ready drives, select the two drives that you want to group into the array.
5. Click the icon on the toolbar to add the selected drives to the array.
6. If you want to configure a hot-spare drive, complete the following steps:
 - a. Click the **Spares** tab.
 - b. Select the physical drive that you want to designate as the hot-spare drive, and the icon on the toolbar to add the selected drives.

7. Click **Next**. The “Configuration summary” window opens.
8. Review the information in the “Configuration summary” window. To change the configuration, click **Back**.
9. Click **Apply**; then, click **Yes** when asked if you want to apply the new configuration. The configuration is saved in the controller and in the physical drives.
10. Exit from ServeRAID Manager and remove the CD from the DVD-ROM drive.
11. Restart the server.

Viewing the configuration

You can use ServeRAID Manager to view information about RAID controllers and the RAID subsystem (such as arrays, logical drives, hot-spare drives, and physical drives). When you click an object in the ServeRAID Manager tree, information about that object appears in the right pane. To display a list of available actions for an object, click the object and click **Actions**.

Updating IBM Director

If you plan to use IBM Director to manage the server, you must check for the latest applicable IBM Director updates and interim fixes.

To install the IBM Director updates and any other applicable updates and interim fixes, complete the following steps.

Note: Changes are made periodically to the IBM Web site. The actual procedure might vary slightly from what is described in this document.

1. Check for the latest version of IBM Director:
 - a. Go to <http://www.ibm.com/systems/management/downloads.html>.
 - b. If the drop-down list shows a newer version of IBM Director than what comes with the server, follow the instructions on the Web page to download the latest version.
2. Install the IBM Director program.
3. Download and install any applicable updates or interim fixes for the server:
 - a. Go to <http://www.ibm.com/support/>.
 - b. Click **Downloads and drivers**.
 - c. From the **Category** list, select **xSeries (Intel and AMD processor-based)**.
 - d. From the **Sub-category** list, select **System x3500** and click **Continue**.
 - e. In the **Search within results** field, type **director** and click **Search**.
 - f. Select any applicable update or interim fix that you want to download.
 - g. Click the link for the executable (.exe) file to download the file, and follow the instructions in the readme file to install the update or interim fix.
 - h. Repeat steps 3f and 3g for any additional updates or interim fixes that you want to install.

Appendix. Notices

This information was developed for products and services offered in the U.S.A.

IBM may not offer the products, services, or features discussed in this document in other countries. Consult your local IBM representative for information on the products and services currently available in your area. Any reference to an IBM product, program, or service is not intended to state or imply that only that IBM product, program, or service may be used. Any functionally equivalent product, program, or service that does not infringe any IBM intellectual property right may be used instead. However, it is the user's responsibility to evaluate and verify the operation of any non-IBM product, program, or service.

IBM may have patents or pending patent applications covering subject matter described in this document. The furnishing of this document does not give you any license to these patents. You can send license inquiries, in writing, to:

*IBM Director of Licensing
IBM Corporation
North Castle Drive
Armonk, NY 10504-1785
U.S.A.*

INTERNATIONAL BUSINESS MACHINES CORPORATION PROVIDES THIS PUBLICATION "AS IS" WITHOUT WARRANTY OF ANY KIND, EITHER EXPRESS OR IMPLIED, INCLUDING, BUT NOT LIMITED TO, THE IMPLIED WARRANTIES OF NON-INFRINGEMENT, MERCHANTABILITY OR FITNESS FOR A PARTICULAR PURPOSE. Some states do not allow disclaimer of express or implied warranties in certain transactions, therefore, this statement may not apply to you.

This information could include technical inaccuracies or typographical errors. Changes are periodically made to the information herein; these changes will be incorporated in new editions of the publication. IBM may make improvements and/or changes in the product(s) and/or the program(s) described in this publication at any time without notice.

Any references in this information to non-IBM Web sites are provided for convenience only and do not in any manner serve as an endorsement of those Web sites. The materials at those Web sites are not part of the materials for this IBM product, and use of those Web sites is at your own risk.

IBM may use or distribute any of the information you supply in any way it believes appropriate without incurring any obligation to you.

Trademarks

The following terms are trademarks of International Business Machines Corporation in the United States, other countries, or both:

IBM	FlashCopy	TechConnect
IBM (logo)	i5/OS	Tivoli
Active Memory	IntelliStation	Tivoli Enterprise
Active PCI	NetBAY	Update Connector
Active PCI-X	Netfinity	Wake on LAN

AIX	PowerExecutive	XA-32
Alert on LAN	Predictive Failure Analysis	XA-64
BladeCenter	ServeRAID	X-Architecture
Chipkill	ServerGuide	XpandOnDemand
e-business logo	ServerProven	xSeries
@server	System x	

Intel, Intel Xeon, Itanium, and Pentium are trademarks of Intel Corporation in the United States, other countries, or both.

Microsoft, Windows, and Windows NT are trademarks of Microsoft Corporation in the United States, other countries, or both.

UNIX is a registered trademark of The Open Group in the United States and other countries.

Java and all Java-based trademarks and logos are trademarks of Sun Microsystems, Inc. in the United States, other countries, or both.

Adaptec and HostRAID are trademarks of Adaptec, Inc., in the United States, other countries, or both.

Linux is a trademark of Linus Torvalds in the United States, other countries, or both.

Red Hat, the Red Hat “Shadow Man” logo, and all Red Hat-based trademarks and logos are trademarks or registered trademarks of Red Hat, Inc., in the United States and other countries.

Other company, product, or service names may be trademarks or service marks of others.

Important notes

Processor speed indicates the internal clock speed of the microprocessor; other factors also affect application performance.

CD or DVD drive speed is the variable read rate. Actual speeds vary and are often less than the possible maximum.

When referring to microprocessor storage, real and virtual storage, or channel volume, KB stands for approximately 1000 bytes, MB stands for approximately 1 000 000 bytes, and GB stands for approximately 1 000 000 000 bytes.

When referring to hard disk drive capacity or communications volume, MB stands for 1 000 000 bytes, and GB stands for 1 000 000 000 bytes. Total user-accessible capacity can vary depending on operating environments.

Maximum internal hard disk drive capacities assume the replacement of any standard hard disk drives and population of all hard disk drive bays with the largest currently supported drives that are available from IBM.

Maximum memory might require replacement of the standard memory with an optional memory module.

IBM makes no representation or warranties regarding non-IBM products and services that are ServerProven[®], including but not limited to the implied warranties of merchantability and fitness for a particular purpose. These products are offered and warranted solely by third parties.

IBM makes no representations or warranties with respect to non-IBM products. Support (if any) for the non-IBM products is provided by the third party, not IBM.

Some software might differ from its retail version (if available) and might not include user manuals or all program functionality.

Product recycling and disposal

This unit must be recycled or discarded according to applicable local and national regulations. IBM encourages owners of information technology (IT) equipment to responsibly recycle their equipment when it is no longer needed. IBM offers a variety of product return programs and services in several countries to assist equipment owners in recycling their IT products. Information on IBM product recycling offerings can be found on IBM's Internet site at <http://www.ibm.com/ibm/environment/products/prp.shtml>.

Esta unidad debe reciclarse o desecharse de acuerdo con lo establecido en la normativa nacional o local aplicable. IBM recomienda a los propietarios de equipos de tecnología de la información (TI) que reciclen responsablemente sus equipos cuando éstos ya no les sean útiles. IBM dispone de una serie de programas y servicios de devolución de productos en varios países, a fin de ayudar a los propietarios de equipos a reciclar sus productos de TI. Se puede encontrar información sobre las ofertas de reciclado de productos de IBM en el sitio web de IBM <http://www.ibm.com/ibm/environment/products/prp.shtml>.

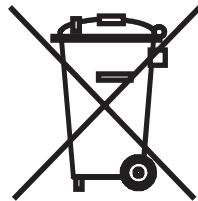

Notice: This mark applies only to countries within the European Union (EU) and Norway.

This appliance is labeled in accordance with European Directive 2002/96/EC concerning waste electrical and electronic equipment (WEEE). The Directive determines the framework for the return and recycling of used appliances as applicable throughout the European Union. This label is applied to various products to indicate that the product is not to be thrown away, but rather reclaimed upon end of life per this Directive.

注意: このマークは EU 諸国およびノルウェーにおいてのみ適用されます。

この機器には、EU 諸国に対する廃電気電子機器指令 2002/96/EC(WEEE) のラベルが貼られています。この指令は、EU 諸国に適用する使用済み機器の回収とリサイクルの骨子を定めています。このラベルは、使用済みになった時に指令に従って適正な処理をする必要があることを知らせるために種々の製品に貼られています。

Remarque : Cette marque s'applique uniquement aux pays de l'Union Européenne et à la Norvège.

L'étiquette du système respecte la Directive européenne 2002/96/EC en matière de Déchets des Equipements Electriques et Electroniques (DEEE), qui détermine les dispositions de retour et de recyclage applicables aux systèmes utilisés à travers l'Union européenne. Conformément à la directive, ladite étiquette précise que le produit sur lequel elle est apposée ne doit pas être jeté mais être récupéré en fin de vie.

In accordance with the European WEEE Directive, electrical and electronic equipment (EEE) is to be collected separately and to be reused, recycled, or recovered at end of life. Users of EEE with the WEEE marking per Annex IV of the WEEE Directive, as shown above, must not dispose of end of life EEE as unsorted municipal waste, but use the collection framework available to customers for the return, recycling, and recovery of WEEE. Customer participation is important to minimize any potential effects of EEE on the environment and human health due to the potential presence of hazardous substances in EEE. For proper collection and treatment, contact your local IBM representative.

Battery return program

This product may contain a sealed lead acid, nickel cadmium, nickel metal hydride, lithium, or lithium ion battery. Consult your user manual or service manual for specific battery information. The battery must be recycled or disposed of properly. Recycling facilities may not be available in your area. For information on disposal of batteries outside the United States, go to <http://www.ibm.com/ibm/environment/products/index.shtml> or contact your local waste disposal facility.

In the United States, IBM has established a return process for reuse, recycling, or proper disposal of used IBM sealed lead acid, nickel cadmium, nickel metal hydride, and battery packs from IBM equipment. For information on proper disposal of these batteries, contact IBM at 1-800-426-4333. Have the IBM part number listed on the battery available prior to your call.

For Taiwan: Please recycle batteries.



For the European Union:

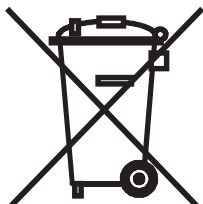

Notice: This mark applies only to countries within the European Union (EU).

Batteries or packaging for batteries are labeled in accordance with European Directive 2006/66/EC concerning batteries and accumulators and waste batteries and accumulators. The Directive determines the framework for the return and recycling of used batteries and accumulators as applicable throughout the European Union. This label is applied to various batteries to indicate that the battery is not to be thrown away, but rather reclaimed upon end of life per this Directive.

Les batteries ou emballages pour batteries sont étiquetés conformément aux directives européennes 2006/66/EC, norme relative aux batteries et accumulateurs en usage et aux batteries et accumulateurs usés. Les directives déterminent la marche à suivre en vigueur dans l'Union Européenne pour le retour et le recyclage des batteries et accumulateurs usés. Cette étiquette est appliquée sur diverses batteries pour indiquer que la batterie ne doit pas être mise au rebut mais plutôt récupérée en fin de cycle de vie selon cette norme.

バッテリーあるいはバッテリー用のパッケージには、EU 諸国に対する廃電気電子機器指令 2006/66/EC のラベルが貼られています。この指令は、バッテリーと蓄電池、および廃棄バッテリーと蓄電池に関するものです。この指令は、使用済みバッテリーと蓄電池の回収とリサイクルの骨子を定めているもので、EU 諸国にわたって適用されます。このラベルは、使用済みになったときに指令に従って適正な処理をする必要があることを知らせるために種々のバッテリーに貼られています。

In accordance with the European Directive 2006/66/EC, batteries and accumulators are labeled to indicate that they are to be collected separately and recycled at end of life. The label on the battery may also include a chemical symbol for the metal concerned in the battery (Pb for lead, Hg for mercury, and Cd for cadmium). Users of batteries and accumulators must not dispose of batteries and accumulators as unsorted municipal waste, but use the collection framework available to customers for the return, recycling, and treatment of batteries and accumulators. Customer participation is important to minimize any potential effects of batteries and accumulators on the environment and human health due to the potential presence of hazardous substances. For proper collection and treatment, contact your local IBM representative.

This notice is provided in accordance with Royal Decree 106/2008 of Spain: The retail price of batteries, accumulators, and power cells includes the cost of the environmental management of their waste.

For California:

Perchlorate material – special handling may apply. See <http://www.dtsc.ca.gov/hazardouswaste/perchlorate/>.

The foregoing notice is provided in accordance with California Code of Regulations Title 22, Division 4.5 Chapter 33. Best Management Practices for Perchlorate Materials. This product/part may include a lithium manganese dioxide battery which contains a perchlorate substance.

Electronic emission notices

Federal Communications Commission (FCC) statement

Note: This equipment has been tested and found to comply with the limits for a Class A digital device, pursuant to Part 15 of the FCC Rules. These limits are

designed to provide reasonable protection against harmful interference when the equipment is operated in a commercial environment. This equipment generates, uses, and can radiate radio frequency energy and, if not installed and used in accordance with the instruction manual, may cause harmful interference to radio communications. Operation of this equipment in a residential area is likely to cause harmful interference, in which case the user will be required to correct the interference at his own expense.

Properly shielded and grounded cables and connectors must be used in order to meet FCC emission limits. IBM is not responsible for any radio or television interference caused by using other than recommended cables and connectors or by unauthorized changes or modifications to this equipment. Unauthorized changes or modifications could void the user's authority to operate the equipment.

This device complies with Part 15 of the FCC Rules. Operation is subject to the following two conditions: (1) this device may not cause harmful interference, and (2) this device must accept any interference received, including interference that may cause undesired operation.

Industry Canada Class A emission compliance statement

This Class A digital apparatus complies with Canadian ICES-003.

Avis de conformité à la réglementation d'Industrie Canada

Cet appareil numérique de la classe A est conforme à la norme NMB-003 du Canada.

Australia and New Zealand Class A statement

Attention: This is a Class A product. In a domestic environment this product may cause radio interference in which case the user may be required to take adequate measures.

United Kingdom telecommunications safety requirement

Notice to Customers

This apparatus is approved under approval number NS/G/1234/J/100003 for indirect connection to public telecommunication systems in the United Kingdom.

European Union EMC Directive conformance statement

This product is in conformity with the protection requirements of EU Council Directive 89/336/EEC on the approximation of the laws of the Member States relating to electromagnetic compatibility. IBM cannot accept responsibility for any failure to satisfy the protection requirements resulting from a nonrecommended modification of the product, including the fitting of non-IBM option cards.

This product has been tested and found to comply with the limits for Class A Information Technology Equipment according to CISPR 22/European Standard EN 55022. The limits for Class A equipment were derived for commercial and industrial environments to provide reasonable protection against interference with licensed communication equipment.

Attention: This is a Class A product. In a domestic environment this product may cause radio interference in which case the user may be required to take adequate measures.

European Community contact:
IBM Technical Regulations
Pascalstr. 100, Stuttgart, Germany 70569
Telephone: 0049 (0)711 785 1176
Fax: 0049 (0)711 785 1283
E-mail: tjahn@de.ibm.com

Taiwanese Class A warning statement

警告使用者：
這是甲類的資訊產品，在
居住的環境中使用時，可
能會造成射頻干擾，在這
種情況下，使用者會被要
求採取某些適當的對策。

Chinese Class A warning statement

聲 明
此為 A 級產品。在生活環境中，
該產品可能會造成無線電干擾。
在這種情況下，可能需要用戶對其
干擾採取切实可行的措施。

Japanese Voluntary Control Council for Interference (VCCI) statement

この装置は、情報処理装置等電波障害自主規制協議会（VCCI）の基準に
基づくクラスA情報技術装置です。この装置を家庭環境で使用すると電波妨害を
引き起こすことがあります。この場合には使用者が適切な対策を講ずるよう要求
されることがあります。

Index

A

- adapter
 - boot option 25
 - hot-plug devices 35
 - installing 25
 - hot-plug 35
 - PCI bus, identification 25
 - ServeRAID 35
 - ServeRAID-MR10is
 - installing 27
 - types and installation information 24
- administrator password 55, 58, 59
- advanced setup 56
- attention notices 2
- availability 5

B

- baseboard management controller utility programs 72
- battery return program 84
- bays 3
- bezel, removing 23
- Boot Menu program 53, 73
- boot sequence 56
- Broadcom Gigabit Ethernet Utility
 - enabling 73
 - general information 53

C

- cable routing 50
- cabling
 - external 50
 - ServeRAID-MR10is adapter 27
 - the server 50
- cache 3
- cache control 56
- caution statements 2
- Class A electronic emission notice 85
- command-line interface
 - commands
 - identify 72
 - power 72
 - sel 72
 - sysinfo 72
 - for remote management 72
- completing the installation 49
- configuration 50
 - Broadcom Gigabit Ethernet Utility 53
 - configuration wizard 78
 - Configuration/Setup Utility 53
 - Ethernet controller 74
 - ports 55
 - ServeRAID programs 53
 - ServerGuide Setup and Installation CD 53
 - viewing 79
 - with ServerGuide 60

- configuring
 - RAID controller 76
 - SAS devices 76
- connecting the cables 50
- connectors
 - on front of server 8
 - on rear of server 10
- controller
 - configuring with ServeRAID Manager 78
 - enabling 55
 - Ethernet, configuring 74
- cooling 5
- CPU LED 18

D

- danger statements 2
- DASD LED 19
- data rate, Ethernet 74
- Device Driver and IBM Enhanced Diagnostics CD 4
- device drivers 7
- diagnostics CD 4
- dimensions 3
- DIMM
 - installation 42
 - installation order 42
 - removal 42
 - types and installation information 37
- drives 3, 4
- DVD
 - drive 31
 - drive activity LED 9
 - eject button 9

E

- electrical input 3
- electronic emission Class A notice 85
- enabling
 - Broadcom Gigabit Ethernet Utility 73
 - controllers 55
- environment 3
- error logs 57
- Ethernet 4
 - connector 10
 - controller
 - configuring 74
 - enabling 55
 - high performance modes 74
 - integrated on system board 74
 - modes 74
 - utility, enabling 73
- expansion
 - bays 3
 - slots 3
- external cabling 50

F

- FAN LED 19
- fans 3, 5
- FCC Class A notice 85
- features 3
 - and technologies 4
 - RAS 5
 - server power 11
 - ServerGuide 60
- filler panel, hard disk drive bay 35
- firmware code, updating 72
- full-high tape drive 32

H

- handling static-sensitive devices 22
- hard disk drive
 - activity LED 8
 - installation 35
 - removal 34
 - status LED 9
 - types and installation information 34
- heat output 3
- hot-plug adapter.
See adapter
- hot-swap and hot-plug devices
 - adapters 35
- humidity 3

I

- IBM Configuration/Setup Utility program
 - menu choices 54
 - starting 54
 - using 54
- IBM Director 4, 6, 79
- important notices 2
- installation
 - completing 49
 - guidelines 21
 - order, memory modules 42
 - VRM 45
- installing
 - adapter 24, 25
 - DIMMs 42
 - DVD drive 31
 - full-high tape drive 32
 - hot-plug adapter 35
 - hot-swap hard disk drive 35
 - memory 37
 - microprocessor 44
 - options 13
 - redundant power and cooling option 45
 - ServerRAID-MR10is adapter 27
 - USB tape drive 33
 - VRM 45
- integrated functions 3

J

- jumper, power-on password override 59

K

- keyboard connector 10

L

- LEDs
 - diagnostics 6
 - front of server 8
 - rear of server 10
- LEDs, light path
 - CPU 18
 - DASD 19
 - FAN 19
 - MEM 19
 - NMI 20
 - PCI BRD 19
 - SP 19
 - TEMP 18
 - VRM 18
- light path diagnostics
 - LEDs 4, 16
 - panel 16
- local area network (LAN) 4

M

- MEM LED 19
- memory 3, 4
- memory module order of installation 42
- microprocessor 3, 5
 - cache 56
 - installation 44
 - type and installation information 43
- modes, Ethernet 74
- mouse connector 10

N

- network operating system (NOS) installation
 - with ServerGuide 61
 - without ServerGuide 61
- NMI LED 20
- noise emissions 3
- notes 2
- notes, important 82
- notices
 - electronic emission 85
 - FCC, Class A 85
- notices and statements 2

O

- online publications 2
- order of installation, memory modules 42
- OSA SMBridge management utility program
 - enabling and configuring 62

OSA SMBridge management utility program *(continued)*
installing 70

P

parallel connector 10
password
 administrator 55, 58, 59
 forgotten power-on 58
 power on, override jumper 59
 power-on 58
 setting 55
 using 58
PCI
 BRD LED 19
 slot 1 25
 slot 6 25
 slots 2 and 3 25
 slots 4 and 5 25
peripheral component interconnect (PCI)
 configuration 56
ports, enabling 55
power
 control button 8
 control button shield 8
 cord connector 10
 features 11
 LED 8
 redundant 45
 requirements 3
 supply cage 47
 working inside system 22
power supply 3
power-on
 password 56, 58
 self-test (POST) error log 57
processor control 56
product recycling and disposal 83
publications 1

R

RAS features 5
recycling and disposal, product 83
redundant power and cooling option 45
reliability 5
Remote Supervisor Adapter 5
Remote Supervisor Adapter II SlimLine
 cabling 75
 installing firmware 75
 requirements 74
 setting up 74
Remote Supervisor Adapter II SlimLine Ethernet
 connector 10
Remote Supervisor Adapter, configuration 53
removing
 a DIMM 42
 a hot-swap hard disk drive 34
 bezel 23
 DVD drive 31
 the left-side cover 24

S

scan order 25
SCSI, hot-swap 6
SDR/FRU, defined 53
serial connector 10
serial over LAN
 commands
 connect 73
 identify 73
 power 73
 reboot 73
 sel get 73
 sol 73
 sysinfo 73
server components 13
ServeRAID
 Manager 77
 programs 53
 support 5
ServeRAID-MR10is adapter, installing 27
ServerGuide
 CD 4
 CDs 53
 features 60
 NOS installation 61
 Setup and Installation CD 53
 starting the Setup and Installation CD 60
 using 59
serviceability 5
setup
 advanced 56
 Configuration/Setup Utility 54
 with ServerGuide 60
size 3
slots 3
SMP 5
SP LED 19
specifications 3
Standby mode 11
start options 56
starting
 Configuration/Setup Utility program 54
 ServerGuide Setup and Installation CD 60
startup sequence 56
statements and notices 2
supervisor password
 See administrator password
symmetric multiprocessing 5
system
 board, external connectors 16
 board, internal connectors 14
 board, LEDs 15
 error LED 9
 information LED 8
 locator LED 8
 reliability guidelines 22
system event/error log 57
systems management 5, 6

T

- TEMP LED 18
- temperature 3
- trademarks 81
- turning off the server 12
- turning on the server 11

U

- United States electronic emission Class A notice 85
- United States FCC Class A notice 85
- Universal Serial Bus (USB)
 - controller, enabling 55
- UpdateXpress 7
- updating
 - firmware code 72
 - IBM Director 79
 - server configuration 50
- USB
 - connector 9, 10
 - tape drive 33
- user password
 - See power-on password
- using
 - baseboard management controller utility
 - programs 72
 - Boot Menu program 73
 - IBM Configuration/Setup Utility program 53, 54
 - passwords 55, 58
 - ServerGuide 59
- utility
 - Configuration/Setup 54
 - Ethernet 53, 73
- utility program
 - Adaptec RAID Configuration 76

V

- video connector 10
- viewing the configuration
 - Configuration/Setup Utility 54
- VRM
 - installing 45
 - LED 18

W

- Web site
 - ServerGuide 59
- weight 3
- working inside the server with the power on 22



Part Number: 44R5219

Printed in USA

(1P) P/N: 44R5219

